

Adaptive Power MOSFET Driver^b

Features

- dv/dt and di/dt Control
- Undervoltage Protection
- Short-Circuit Protection
- t_{rr} Shoot-Through Current Limiting
- Low Quiescent Current
- CMOS Compatible Inputs
- Compatible with Wide Range of MOSFET Devices
- Bootstrap and Charge Pump Compatible (High-Side Drive)

Description

The Si9910 Power MOSFET driver provides optimized gate drive signals, protection circuitry and logic level interface. Very low quiescent current is provided by a CMOS buffer and a high-current emitter-follower output stage. This efficiency allows operation in high-voltage bridge applications with “bootstrap” or “charge-pump” floating power supply techniques.

The non-inverting output configuration minimizes current drain for an n-channel “on” state. The logic input is internally diode clamped to allow simple pull-down in high-side drives.

Fault protection circuitry senses an undervoltage or output short-circuit condition and disables the power MOSFET. Addition of one external resistor limits maximum di/dt of the external Power MOSFET. A fast feedback circuit may be used to limit shoot-through current during t_{rr} (diode reverse recovery time) in a bridge configuration.

The Si9910 is available in 8-pin plastic DIP and SOIC packages, and are specified over the industrial, D suffix (–40 to 85°C) temperature range.

Functional Block Diagram

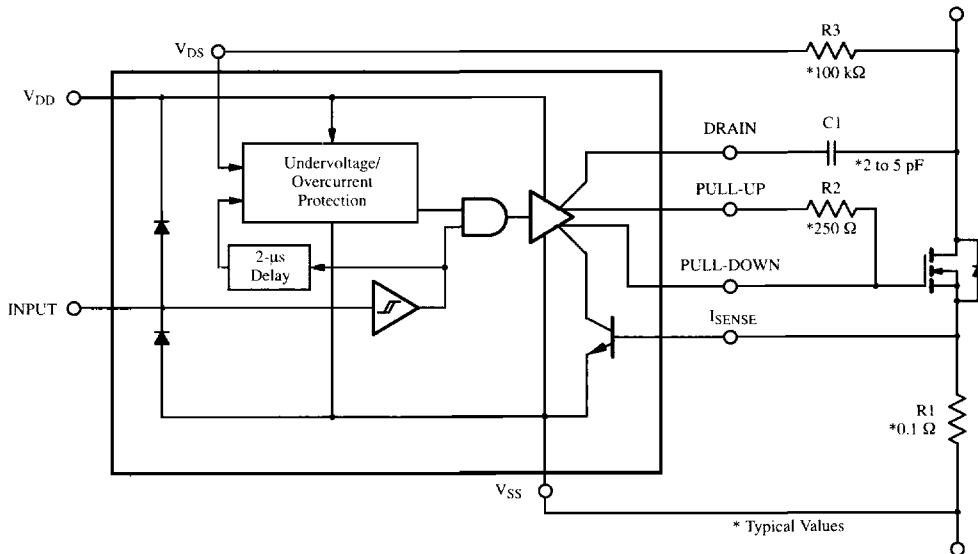

3

Motor Control

Updates to this data sheet may be obtained via facsimile by calling Siliconix FaxBack, 1-408-970-5600. Please request FaxBack document #70009. Applications information may also be obtained via FaxBack, request document #70579.

b. Patent Number 484116.

Absolute Maximum Ratings

Voltages Referenced to V _{SS} Pin	Junction Temperature (T _J)	150°C
V _{DD} Supply Range	Power Dissipation (Package) ^a	
Pin 1, 4, 5, 7, 8	8-Pin SOIC (Y Suffix) ^b	700 mW
Pin 2	8-Pin Plastic DIP (J Suffix) ^b	700 mW
Input Current	Notes	
Peak Current (I _{pk})	a. Device mounted with all leads soldered or welded to PC board.	
Storage Temperature	b. Derate 5.6 mW/°C above 25°C.	
Operating Temperature		

Specifications^a

Parameter	Symbol	Test Conditions Unless Otherwise Specified V _{DD} 10.8 V to 16.5 V T _A = Operating Temperature Range	Limits			Unit
			Min ^c	Typ ^b	Max ^c	
Input						
High Level Input Voltage	V _{IH}		0.70 x V _{DD}	7.4		V
Low Level Input Voltage	V _{IL}			6.0	0.35 x V _{DD}	
Input Voltage Hysteresis	V _h		0.90	2.0	3.0	
High Level Input Current	I _{IH}	V _{IN} = V _{DD}			± 1	µA
Low Level Input Current	I _{IL}	V _{IN} = 0 V			± 1	
Output						
High Level Output Voltage	V _{OH}	I _{OH} = -200 mA	V _{DD} -3	10.7		V
Low Level Output Voltage	V _{OL}	I _{OL} = 200 mA		1.3	3	
Undervoltage Lockout	V _{UVLO}		8.3	9.2	10.6	
I _{SENSE} Pin Threshold	V _{TH}	Max I _S = 2 mA, Input High 100 mV Change on Drain	0.5	0.66	0.8	
Voltage Drain-Source Maximum	V _{DS}	Input High	8.3	9.1	10.2	
Input Current for V _{DS} Input	I _{VDS}			12	20.0	µA
Peak Output Source Current	I _{OS+}			1		A
Peak Output Sink Current	I _{OS-}			-1		
Supply						
Supply Range	V _{DD}		10.8		16.5	V
Supply Current	I _{DD1}	Output High, No Load		0.1	1	µA
	I _{DD2}	Output Low, No Load		100	500	
Dynamic						
Propagation Delay Time Low to High Level	t _{PLH}	C _L = 2000 pF		120		ns
Propagation Delay Time High to Low Level	t _{PHL}			135		
Rise Time	t _r			50		
Fall Time	t _f			35		
Overcurrent Sense Delay (V _{DS})	t _{DS}				1	
Input Capacitance	C _{in}			5	pF	

Notes

- Refer to PROCESS OPTION FLOWCHART for additional information.
- Typical values are for DESIGN AID ONLY, not guaranteed nor subject to production testing.
- The algebraic convention whereby the most negative value is a minimum and the most positive a maximum.

AC Testing Conditions

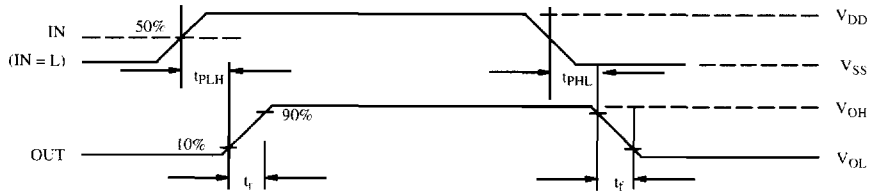

Pin Configurations

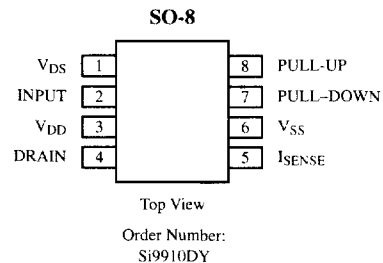
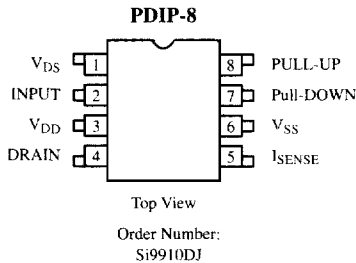

Pin Description

Pin 1: V_{DS}

Pin 1 or V_{DS} is a sense input for the maximum source-drain voltage limit. Two microseconds after a high transition on input pin 2, an internal timer enables the $V_{DS(max)}$ sense circuitry. A catastrophic overcurrent condition, excessive on-resistance, or insufficient gate-drive voltage can be sensed by limiting the maximum voltage drop across the power MOSFET. An external resistor (R3) is required to protect pin 1 from overvoltage during the MOSFET "off" condition. Exceeding $V_{DS(max)}$ latches the Si9910 "off." Drive is re-enabled on the next positive-going input on pin 2. If pin 1 is not used, it must be connected to pin 6 (V_{SS}).

Pin 2: INPUT

A non-inverting, Schmidt trigger input controls the state of the MOSFET gate-drive outputs and enables the protection logic. When the input is low ($\leq V_{IL}$), V_{DD} is monitored for an undervoltage condition (insufficiently charged bootstrap capacitor). If an undervoltage

($\leq V_{DD(min)}$) condition exists, the driver will ignore a turn-on input signal. An undervoltage ($\leq V_{DD(min)}$) condition during an "on" state will not be sensed.

Pin 3: V_{DD}

V_{DD} supplies power for the driver's internal circuitry and charging current for the power MOSFET's gate capacitance. The Si9910 minimizes the internal I_{DD} in the "on" state (gate-drive outputs high) allowing a "floating" power supply to be provided by charge pump or bootstrap techniques.

Pin 4: DRAIN

Drain is an analog input to the internal dv/dt limiting circuitry. An external capacitor (C1) must be used to protect the input from exposure to the high-voltage ("off" state) drain and to set the power MOSFET's maximum rate of dv/dt. If dv/dt feedback is not used, pin 4 must be left open.

Pin Description (Cont'd)

Pin 5: I_{SENSE}

I_{SENSE} in combination with an external resistor (R₁) protects the power MOSFET from potentially catastrophic peak currents. I_{SENSE} is an analog feedback that limits current during the power MOSFET's transition to an "on" state. It is intended to protect power MOSFETs (in a half-bridge arrangement) from "shoot-through" current, resulting from excess di/dt and t_{rr} of flyback diodes or from logic timing overlap. An 0.8-V drop across (R₁) should indicate a current level that is approximately four times the maximum allowable load current. When the I_{SENSE} input is not used, it should be tied to pin 6 (V_{SS}).

Pin 6: V_{SS}

V_{SS} is the driver's ground return pin. The applications diagram illustrates the connection of V_{SS} for source-referenced "floating" applications (half-bridge, high-side) and ground-referenced applications (half-bridge, low-side).

Pin 7: PULL-DOWN

Pin 8: PULL-UP

Pull-up and pull-down outputs collectively provide the power MOSFET gate with charging and discharging currents. Turn "on" or "off" di/dt can be limited by adding resistance (R₂) in series with the appropriate output.

Applications

"Floating" High-Side Drive Applications

As demonstrated in Figure 1, the Si9910 is intended for use as both a ground-referenced gate driver and as a "high-side" or source-referenced gate driver in half-bridge applications. Several features of the Si9910 permit its use in half-bridge high-side drive applications.

A simple and inexpensive method of isolating a floating supply to power the Si9910 in high-side driver applications had to be provided. Therefore, the Si9910 was designed to be compatible with two of the most commonly used floating supply techniques: the bootstrap and the charge pump. Both of these techniques have limitations when used alone. A properly designed bootstrap circuit can provide low-impedance drive which minimizes transition losses and the charge pump circuit provides static operation.

The Si9910 is configured to take advantage of either floating supply technique if the application is not sensitive to their particular limitations, or both techniques if switching losses must be minimized and static operation is necessary. The schematic above illustrates both the charge pump and bootstrap circuits used in conjunction with an Si9910 in a high-side driver application.

Input signal level shifting is accomplished with a passive pull-up (R₄) and the Siliconix VN50300 (500-V/300-Ω)

MOSFET for pull-down in applications below 500 V. Complete specifications for the VN50300 can be found in the Siliconix Low-Power Discretes Data Book. One of the VN50300's most important features in this application is its extremely low C_{oss} (output or drain) capacitance. C_{oss} (typically 5 pF), plus the Si9910's input capacitance (also typically 5 pF) plus any stray board capacitance. Total node capacitance defines the value of R₄ needed to guarantee an input transition rate which safely exceeds the maximum dv/dt rate of the output half-bridge. Another feature of the VN50300 is its inherently low saturation current. Using level-shift devices with higher current capabilities may necessitate the addition of current-limiting components such as R₅.

Bootstrap Undervoltage Lockout

When using a bootstrap capacitor as a high-side floating supply, care must be taken to ensure time is available to recharge the bootstrap capacitor prior to turn-on of the high-side MOSFET. As a catastrophic protection against abnormal conditions such as start-up, loss of power, etc., an internal voltage monitor has been included which monitors the bootstrap voltage when the Si9910 is in the low state. The Si9910 will not respond to a high input signal until the voltage on the bootstrap capacitor is sufficient to fully enhance the power MOSFET gate. For more details, please refer to Application Note AN705, which may be obtained via FaxBack, request document #8705.

Applications (Cont'd)

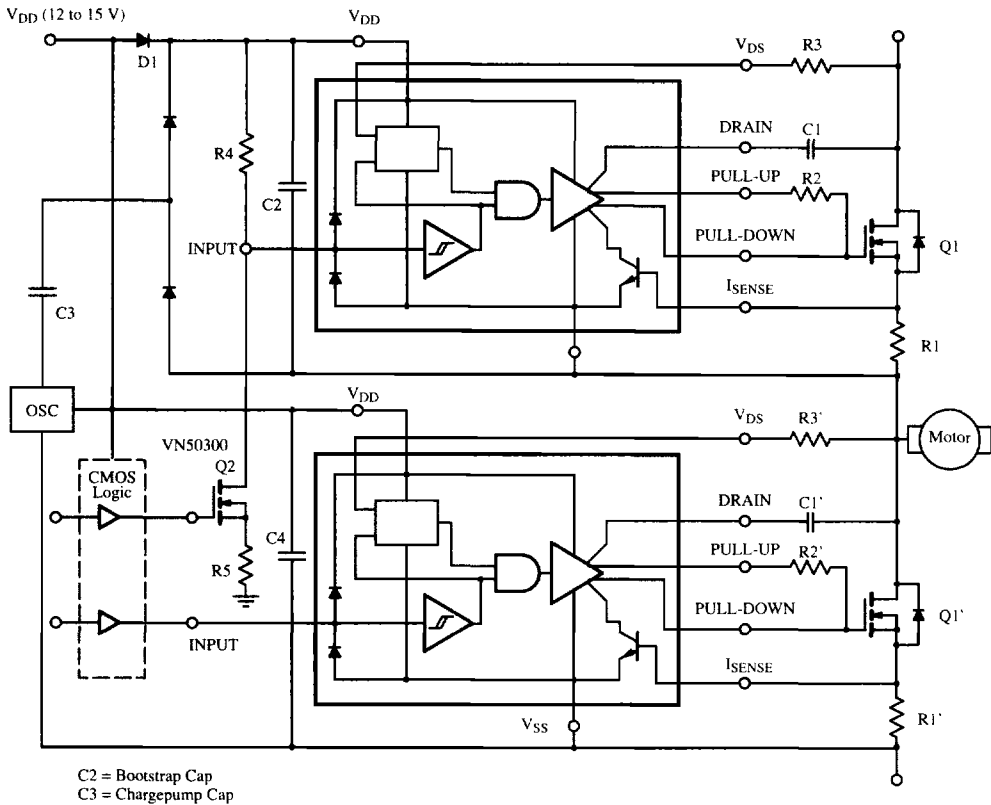

Figure 1. High-Voltage Half-Bridge with Si9910 Drivers