



V A N T I X
AN AND COMPANY

FINAL

COM'L: -10/12/15

IND:-12/14/18

MACH4-256/MACH4LV-256

High-Performance EE CMOS Programmable Logic

DISTINCTIVE CHARACTERISTICS

- ◆ **208 pins in PQFP**
- ◆ **256 macrocells**
- ◆ **10 ns t_{PD} Commercial, 12 ns t_{PD} Industrial**
- ◆ **100 MHz f_{CNT}**
- ◆ **128 I/Os; 14 dedicated inputs**
- ◆ **384 flip-flops**
 - 256 Macrocell flip-flops
 - 128 Input flip-flops
- ◆ **Up to 20 product terms per macrocell, with XOR**
- ◆ **Flexible docking**
 - Four global clock pins with selectable edges
 - Asynchronous mode available for each macrocell
- ◆ **8 MACH111SP-size blocks**
- ◆ **SpeedLocking™ for guaranteed fixed timing**
- ◆ **5-V and 3.3-V supply voltage options**
 - JEDEC compatible for both 5-V and 3.3-V versions
- ◆ **5-V or 3.3-V in-system programmable through JTAG (IEEE Std. 1149.1) interface**
- ◆ **JTAG boundary scan testing capability**
- ◆ **Input and output switch matrices for high routability and pinout retention**
- ◆ **Zero-hold-time input register option**
- ◆ **Peripheral Component Interconnect (PCI) compliant (-10/-12 speed grades)**
- ◆ **Enhanced features**
 - Bus-Friendly™ inputs and I/Os
 - PAL® Block programmable power-down mode for further power saving
 - Individual output slew rate control
 - Both 5-V and 3.3-V supply voltage options are safe for mixed supply voltage system designs
- ◆ **Fully pin-out, function, and JEDEC programming data file compatible with the MACH465**

PLEASE NOTE: The MACH4-256 (M4-256) reflects a new nomenclature for the MACH® 4 Family. This device is currently dual-marked with the M466 ordering part number. The dual-mark scheme will facilitate design and manufacturing flows until we have completely phased in the new M4-256 nomenclature. Please use the MACH466/MACHLV466 data sheet (PID#20981) as a reference.



GENERAL DESCRIPTION

The MACH4-256 (M4-256) and MACH4LV-256 (M4LV-256) are members of Vantis' high-performance EE CMOS MACH 4 family. This device has approximately 8 times the macrocell capability of the popular MACH111SP, with significant additional density and functional features.

The M4-256 (M4LV-256) consists of 16 PAL blocks interconnected by a programmable central switch matrix. The central switch matrix connects the PAL blocks to each other and to all input pins, providing a high degree of connectivity between the PAL blocks. This allows designs to be placed and routed efficiently. Routability is further enhanced by an input switch matrix and an output switch matrix. The input switch matrix provides input signals with alternative paths into the central switch matrix; the output switch matrix provides flexibility in assigning macrocells to I/O pins.

The M4-256 (M4LV-256) has macrocells that can be configured as synchronous or asynchronous. This allows designers to implement both synchronous and asynchronous logic together on the same device. The two types of design can be mixed in any proportion, since the selection on each macrocell affects only that macrocell.

Up to 20 product terms per macrocell can be assigned. It is possible to allocate some product terms away from a macrocell without losing the use of that macrocell for logic generation.

The M4-256 (M4LV-256) macrocell provides either registered or combinatorial outputs with programmable polarity. If a registered configuration is chosen, the register can be configured as D-type, T-type, J-K, or S-R to help reduce the number of product terms used. The flip-flop can also be configured as a latch. The register type decision can be made by the designer using software.

All macrocells can be connected to an I/O cell through the output switch matrix. The output switch matrix makes it possible to make significant design changes while minimizing the risk of pinout changes.

The M4-256 (M4LV-256), an enhanced version of the MACH465, is fully pinout, function and JEDEC programming data file compatible with the MACH465. The enhanced features include: low power consumption; each PAL block has a programmable power-down mode for further power saving of up to 50%; each I/O has an individually programmable output slew-rate control bit; all inputs and 1 I/Os feature the Bus-Friendly circuitry which weakly holds the voltage at the input to a logic low or high level depending on the last driven logic level. Both 5-V and 3.3-V supply operation versions are safe for mixed supply voltage system designs. The 3.3-V supply operation device has its power consumption significantly reduced due to the lower supply voltage, while providing the same high performance as the 5-V device.

Vantis offers software design support for MACH devices through its own development system and device fitters integrated into third-party CAE tools. Platform support extends across PCs, Sun and HP workstations under advanced operating systems such as Windows 3.1, Windows 95 and NT, SunOS and Solaris, and HP-UX.

MACHXL[®] software is a complete development system for the PC, supporting Vantis' MACH devices. It supports design entry with Boolean and behavioral syntax, state machine syntax and truth tables. Functional simulation and static timing analysis are also included in this easy-to-use system. This development system includes high-performance device fitters for all MACH devices.

The same fitter technology included in MACHXL software is seamlessly incorporated into third-party tools from leading CAE vendors such as Synario, Viewlogic, Mentor Graphics, Cadence and MINC. Interface kits and MACHXL configurations are also available to support design entry and verification with other leading vendors such as Synopsys, Exemplar, OrCAD, Synplicity and Model Technology. These MACHXL configurations and interfaces accept EDIF 2.0.0 netlists, generate JEDEC files for MACH devices, and create industry-standard SDF, VITAL-compliant VHDL and Verilog output files for design simulation.

Vantis offers in-system programming support for MACH devices through its MACHPRO[®] software enabling MACH device programmability through JTAG compliant ports and easy-to-use PC interface. Additionally, MACHPRO generated vectors work seamlessly with HP3070, GenRad and Teradyne testers to program MACH devices or test them for connectivity.

All MACH devices are supported by industry standard programmers available from a number of vendors. These programmer vendors include Advin Systems, BP Microsystems, Data I/O Corporation, Hi-Lo Systems, SMS GmbH, Stag House, and System General.

BLOCK DIAGRAM

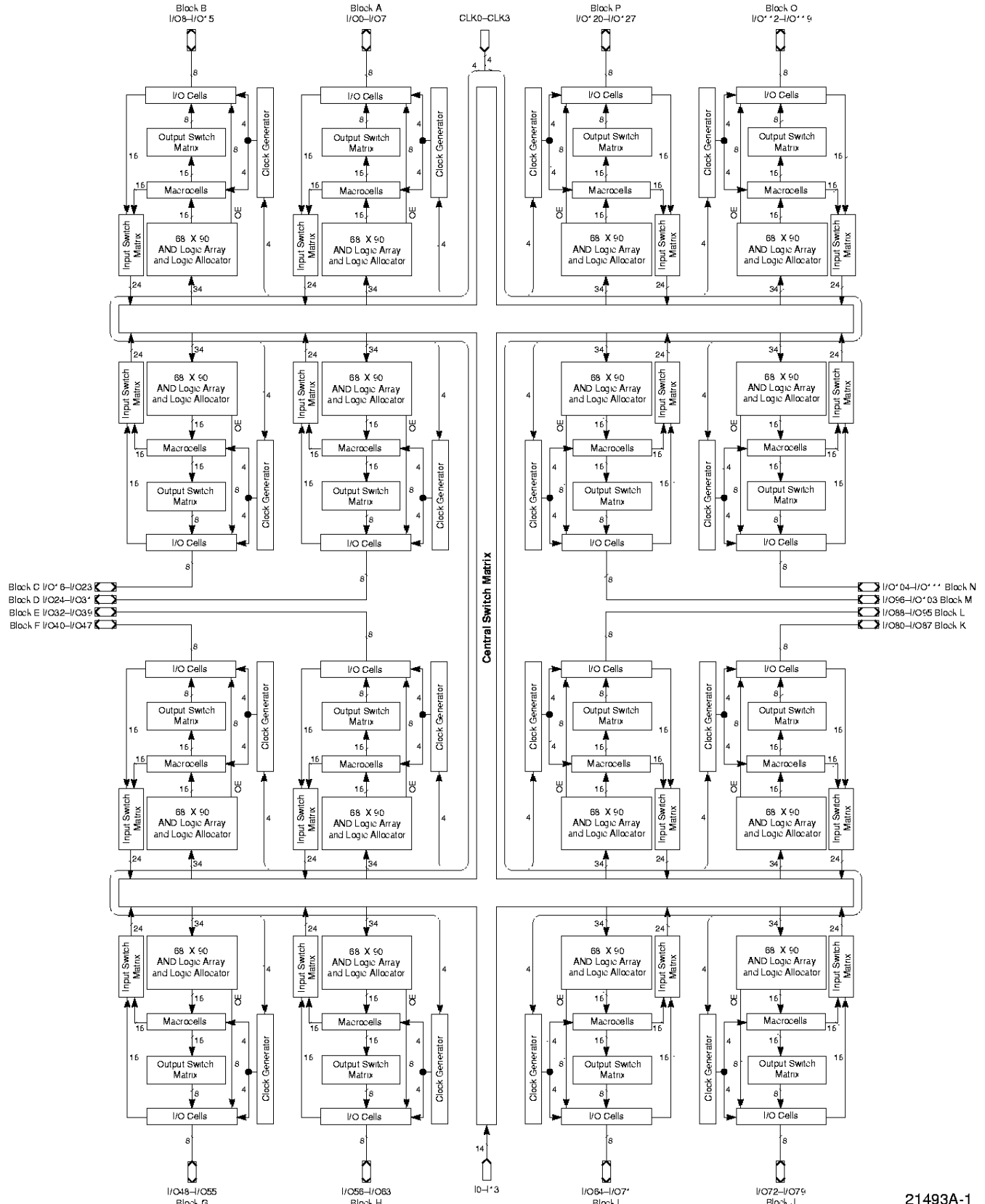

ORDERING INFORMATION

Commercial Products

Vantis programmable logic products for commercial applications are available with several ordering options. The order number (Valid Combination) is formed by a combination of:

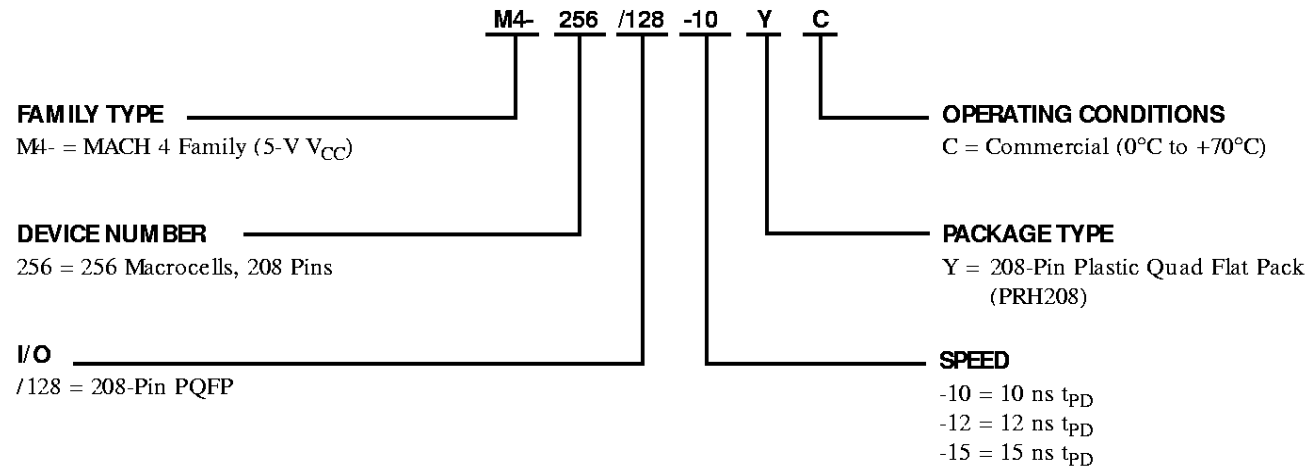

Valid Combinations	
MACH4-256/128-10	YC
MACH4-256/128-12	
MACH4-256/128-15	

Valid Combinations

The Valid Combinations table lists configurations planned to be supported in volume for this device. Consult the local Vantis sales office to confirm availability of specific valid combinations and to check on newly released combinations.

ORDERING INFORMATION

Commercial Products

Vantis programmable logic products for commercial applications are available with several ordering options. The order number (Valid Combination) is formed by a combination of:

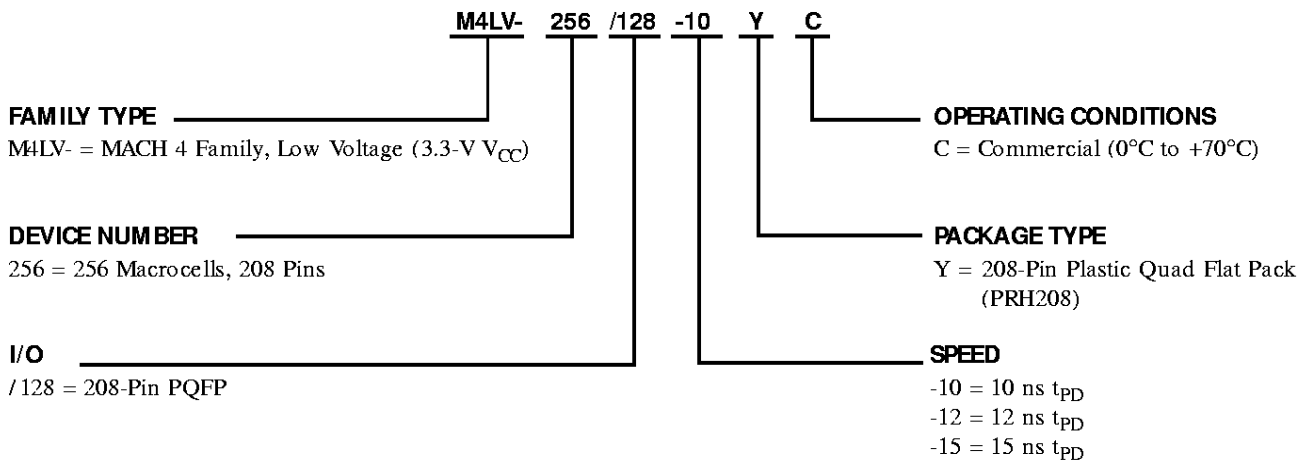

MACH4LV Family

Valid Combinations	
M4LV-256/128-10	YC
M4LV-256/128-12	
M4LV-256/128-15	

Valid Combinations

The Valid Combinations table lists configurations planned to be supported in volume for this device. Consult the local Vantis sales office to confirm availability of specific valid combinations and to check on newly released combinations.

ORDERING INFORMATION

Industrial Products

Vantis programmable logic products for industrial applications are available with several ordering options. The order number (Valid Combination) is formed by a combination of:

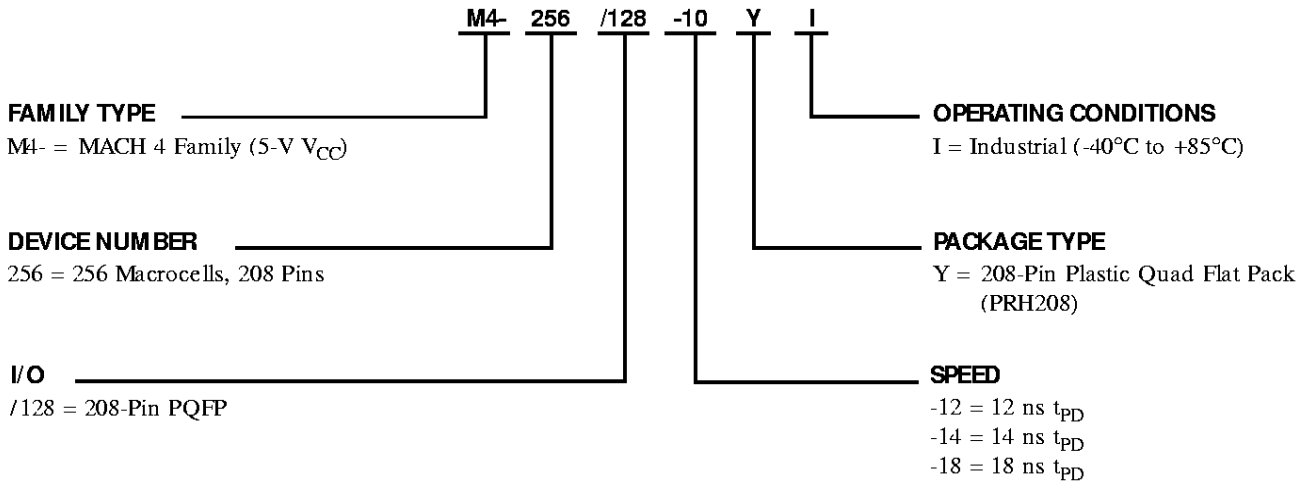

Valid Combinations	
M4-256/128-12	YI
M4-256/128-14	
M4-256/128-18	

Valid Combinations

The Valid Combinations table lists configurations planned to be supported in volume for this device. Consult the local Vantis sales office to confirm availability of specific valid combinations and to check on newly released combinations.

ORDERING INFORMATION

Industrial Products

Vantis programmable logic products for industrial applications are available with several ordering options. The order number (Valid Combination) is formed by a combination of:

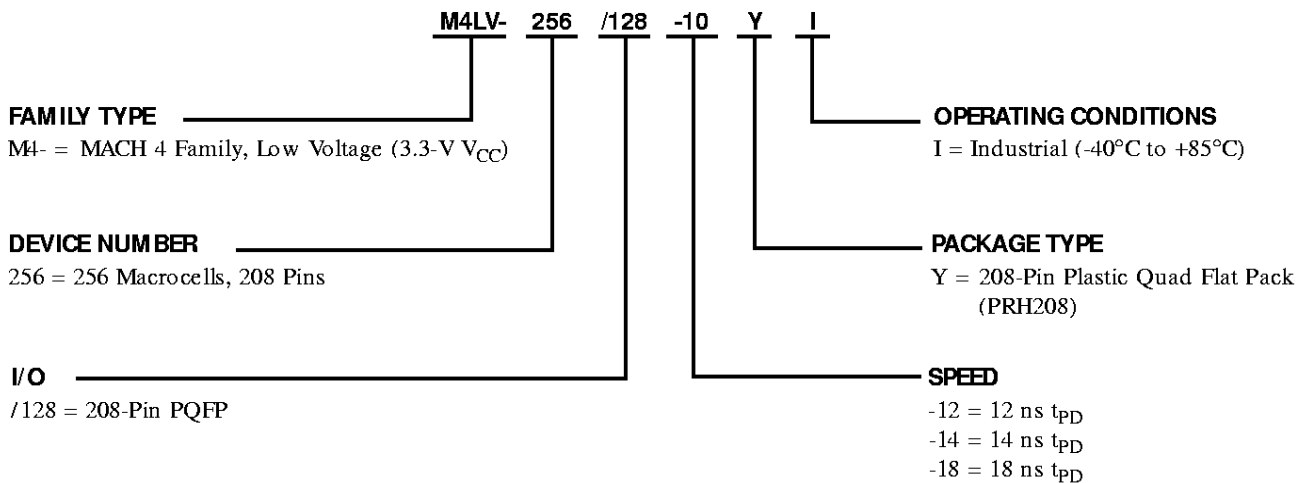

MACH4LV Family

Valid Combinations	
M4LV-256/128-12	YI
M4LV-256/128-14	
M4LV-256/128-18	

Valid Combinations

The Valid Combinations table lists configurations planned to be supported in volume for this device. Consult the local Vantis sales office to confirm availability of specific valid combinations and to check on newly released combinations.

FUNCTIONAL DESCRIPTION

The M4-256 (M4LV-256) consists of sixteen PAL blocks connected by a central switch matrix. There are 128 I/O pins and 14 dedicated input pins feeding the central switch matrix. These signals are distributed to the sixteen PAL blocks for efficient design implementation. There are also 4 global clock pins.

The PAL Blocks

Each PAL block in the M4-256 (M4LV-256) (Figure 7) contains a clock generator, a 90-product-term logic array, a logic allocator, 16 macrocells, an output switch matrix, 8 I/O cells, and an input switch matrix. The central switch matrix feeds each PAL block with 34 inputs. This makes the PAL block look effectively like an independent “PALCE34V16.”

In addition to the logic product terms, individual output enable product terms and two PAL block initialization product terms are provided. Each I/O pin can be individually enabled. All flip-flops that are in the synchronous mode within a PAL block are initialized together by either of the PAL block initialization product terms.

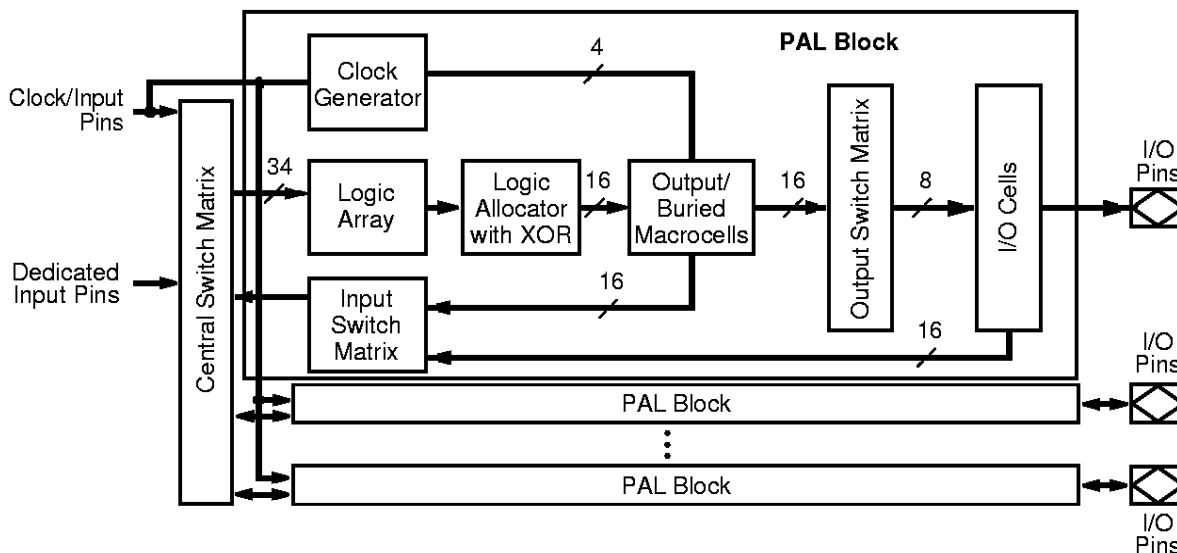

21493A-3

Figure 1. MACH 4 Block Diagram and PAL Block Structure

The Central Switch Matrix and Input Switch Matrix

The M4-256 (M4LV-256) central switch matrix is fed by the input switch matrices in each PAL block. Each PAL block provides 16 internal feedback signals, 8 registered input signals, and 8 I/O pin signals to the input switch matrix. Of these 32 signals, 24 decoded signals are provided to the central switch matrix by the input switch matrix. The central switch matrix distributes these signals back to the PAL blocks in a very efficient manner that provides for high performance. The design software automatically configures the input and central switch matrices when fitting a design into the device. The input switch matrix (Figure 2) optimizes routing of inputs to the central switch matrix. Without the input switch matrix, each input and feedback signal has only one way to enter the central switch matrix. The input switch matrix provides additional ways for these signals to enter the central switch matrix.

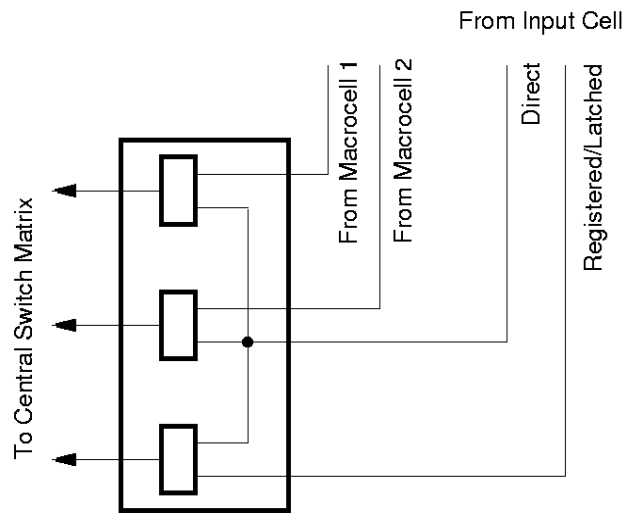

21493A-4

Figure 2. MACH 4 Input Switch Matrix

The Clock Generator

Each PAL block has a clock generator that can generate four clock signals for use throughout the PAL block (Figure 3). These four signals are available to all synchronous mode macrocells and I/O cells in the PAL block. For asynchronous mode macrocells, the first two of these four clock signals are available in addition to the true and complement versions of the individual asynchronous mode macrocell's product term clock. The clock generator chooses the four signals from the eight possible signals given by the true and complement versions of the four global clock pin signals.

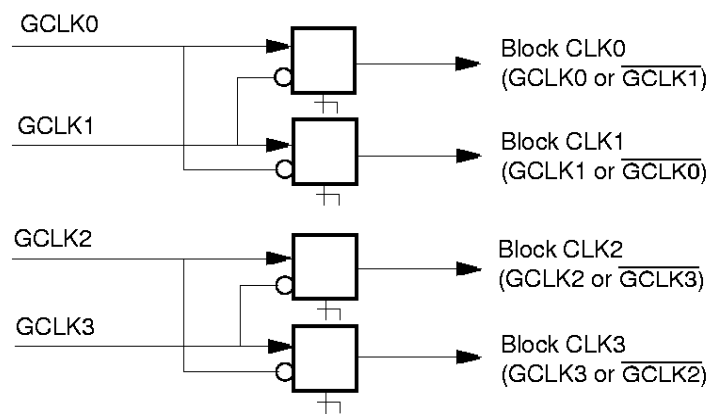

21493A-5

Figure 3. PAL Block Clock Generator

MACH4 Family

Synchronous and Asynchronous Operation

The MACH 4 family can perform synchronous or asynchronous logic. Each individual cell can be programmed as synchronous or asynchronous, allowing unlimited “mixing and matching” of the two logic styles. The selection of synchronous or asynchronous mode affects the logic allocator and the macrocell, since product terms used for logic in the synchronous mode are used for control functions in the asynchronous mode.

The Product-Term Array

The M4-256 (M4LV-256) product-term array consists of 80 product terms for logic use, eight product terms for output enable use, and two product terms for global PAL block initialization. Each macrocell has a nominal allocation of five product terms for logic, although the logic allocator allows for logic redistribution. Each I/O pin has its own individual output enable term. The initialization product terms provide asynchronous reset and preset to synchronous-mode macrocells in the PAL block.

The Logic Allocator

The logic allocator in the M4-256 (M4LV-256) takes the 80 logic product terms and allocates them to the 16 macrocells as needed. Each macrocell can be driven by up to 20 product terms if in synchronous mode, or 18 product terms if in asynchronous mode. When product terms are routed away from a macrocell, it is possible to route all five product terms away, which precludes the use of the macrocell for logic generation; or it is possible to route only four product terms away, leaving one for simple function generation. The design software automatically configures the logic allocator when fitting the design into the device.

The logic allocator also provides an exclusive-OR gate. This gate allows generation of combinatorial exclusive-OR logic, such as comparison or addition. It allows registered exclusive-OR functions, such as CRC generation, to be implemented more efficiently. It also makes it possible to emulate all flip-flop types with a D-type flip-flop. Register type emulation is automatically handled by the design software.

Table 1 illustrates which product term clusters are available to each macrocell within a PAL block. Refer to Figure 7 for cluster and macrocell numbers.

Table 1. Logic Allocation

Output Macrocell	Available Clusters	Output Macrocell	Available Clusters
M ₀	C ₀ , C ₁ , C ₂	M ₈	C ₇ , C ₈ , C ₉ , C ₁₀
M ₁	C ₀ , C ₁ , C ₂ , C ₃	M ₉	C ₈ , C ₉ , C ₁₀ , C ₁₁
M ₂	C ₁ , C ₂ , C ₃ , C ₄	M ₁₀	C ₉ , C ₁₀ , C ₁₁ , C ₁₂
M ₃	C ₂ , C ₃ , C ₄ , C ₅	M ₁₁	C ₁₀ , C ₁₁ , C ₁₂ , C ₁₃
M ₄	C ₃ , C ₄ , C ₅ , C ₆	M ₁₂	C ₁₁ , C ₁₂ , C ₁₃ , C ₁₄
M ₅	C ₄ , C ₅ , C ₆ , C ₇	M ₁₃	C ₁₂ , C ₁₃ , C ₁₄ , C ₁₅
M ₆	C ₅ , C ₆ , C ₇ , C ₈	M ₁₄	C ₁₃ , C ₁₄ , C ₁₅
M ₇	C ₆ , C ₇ , C ₈ , C ₉	M ₁₅	C ₁₄ , C ₁₅

The Macrocell and Output Switch Matrix

The M4-256 (M4LV-256) PAL block has 16 macrocells, half of which can drive I/O pins; this selection is made by the output switch matrix. Each macrocell can drive one of four I/O cells. The allowed combinations are shown in Table 2. Please refer to Figure 7 for macrocell and I/O pin numbers.

Table 2. Output Switch Matrix Combination

Macrocell	Routable to I/O Pins
M0, M1	I/O5, I/O6, I/O7, I/O0
M2, M3	I/O6, I/O7, I/O0, I/O1
M4, M5	I/O7, I/O0, I/O1, I/O2
M6, M7	I/O0, I/O1, I/O2, I/O3
M8, M9	I/O1, I/O2, I/O3, I/O4
M10, M11	I/O2, I/O3, I/O4, I/O5
M12, M13	I/O3, I/O4, I/O5, I/O6
M14, M15	I/O4, I/O5, I/O6, I/O7
I/O Pin	Available Macrocells
I/O0	M0, M1, M2, M3, M4, M5, M6, M7
I/O1	M2, M3, M4, M5, M6, M7, M8, M9
I/O2	M4, M5, M6, M7, M8, M9, M10, M11
I/O3	M6, M7, M8, M9, M10, M11, M12, M13
I/O4	M8, M9, M10, M11, M12, M13, M14, M15
I/O5	M10, M11, M12, M13, M14, M15, M0, M1
I/O6	M12, M13, M14, M15, M0, M1, M2, M3
I/O7	M14, M15, M1, M2, M3, M4, M5

The macrocells can be configured as registered, latched, or combinatorial. In combination with the logic allocator, the registered configuration can be any of the standard flip-flop types. The macrocell provides internal feedback whether configured with or without the flip-flop, and whether or not the macrocell drives an I/O cell.

The flip-flop clock depends on the mode selected for the macrocell. In synchronous mode, any of the PAL block clocks generated by the Clock Generator can be used. In asynchronous mode, either of the first two PAL block clocks can be used. Additionally, the choice of either edge of an individual asynchronous mode macrocell's product term clock is also available.

Initialization can be handled as part of a bank of macrocells via the PAL block initialization terms if in synchronous mode, or individually if in asynchronous mode (Figure 4). In synchronous mode, one of the PAL block product terms is available each for preset and reset. The swap function determines which product term drives which function. This allows initialization polarity compatibility with the MACH 1 and 2 series. In asynchronous mode, one product term can be used either to drive reset or preset.

The output switch matrix allows macrocells to be connected to any of several I/O cells within a PAL block. This provides high flexibility in determining pinout, and allows design changes that will not affect pinout.



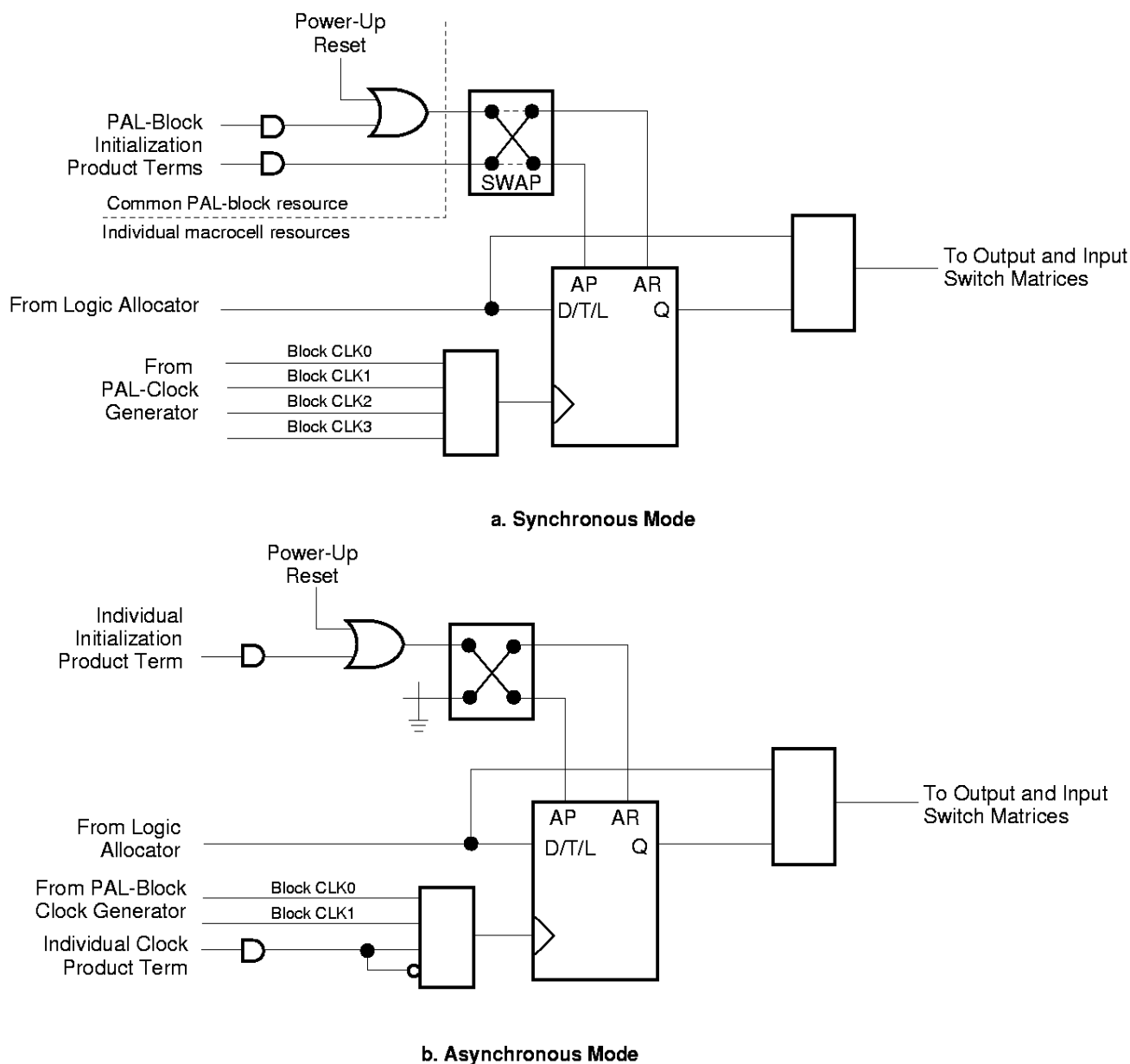

21493A-6

Figure 4. Macrocell

In the MACH 4 devices, each PAL block has twice as many macrocells as I/O cells. The MACH 4 output switch matrix allows for half of the macrocells to drive I/O cells within a PAL block, in combinations according to Figure 5. Each I/O cell can choose from eight macrocells; each macrocell has a choice of four I/O cells.

The I/O Cell

The I/O cell (Figure 6) in the M4-256 (M4LV-256) consists of a three-state buffer and an input flip-flop. The I/O cell is driven by one of the macrocells, as selected by the output switch matrix. Each I/O cell can take its input from one of eight macrocells. The three-state buffer is controlled by an individual product term. The direct I/O signal is available to the input switch matrix, and can be used if desired.

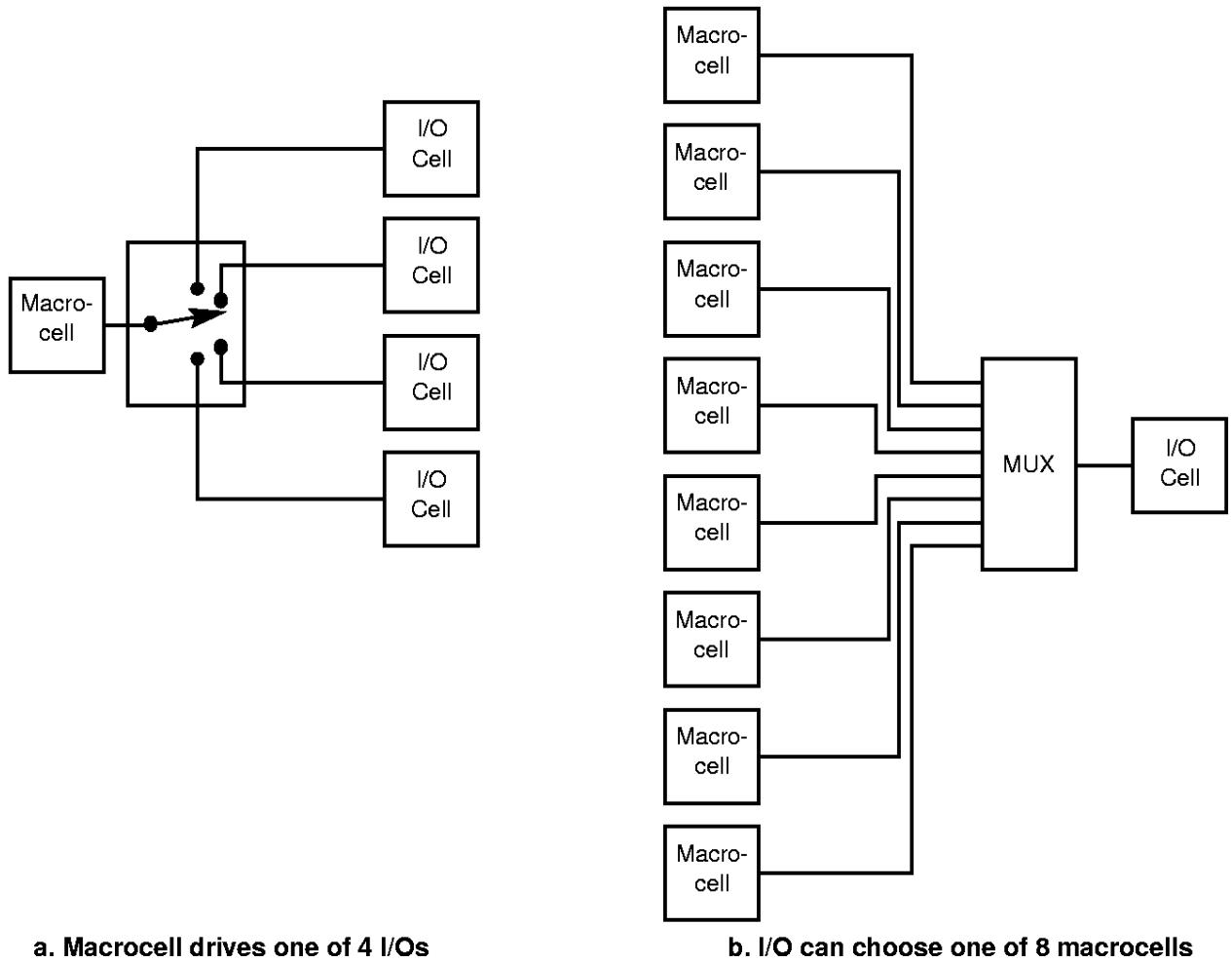

a. Macrocell drives one of 4 I/Os

b. I/O can choose one of 8 macrocells

21493A-7

Figure 5. MACH 4 Output Switch Matrix

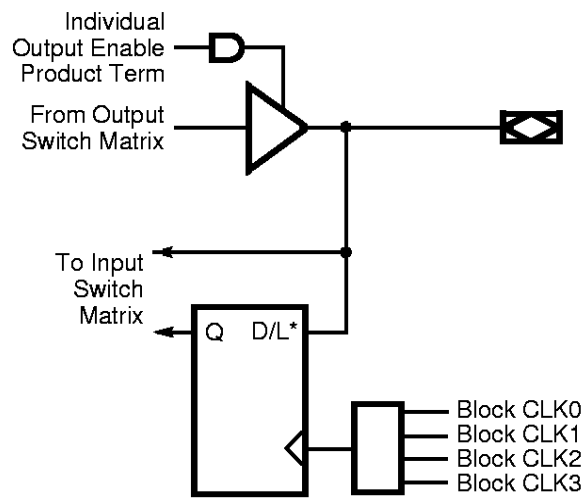

Figure 6. I/O Cell

21493A-8



SpeedLocking for Guaranteed Fixed Timing

The MACH 4 architecture allows allocation of up to 20 product terms to an individual macrocell with the assistance of an XOR gate *without* incurring additional timing delays. Using this architectural strength, the M4-256 (M4LV-256) provides the industry's highest-speed and *only* fixed timing at both 3.3-V and 5-V supply voltages. This SpeedLocking feature delivers guaranteed fixed speed independent of logic path, routing resources, or design refits.

JTAG Testing

JTAG is the commonly used acronym for the IEEE Standard 1149.1-1990. The JTAG standard defines input and output pins, logic control functions, and instructions. Vantis has incorporated this standard into the M4-256 (M4LV-256) device.

The JTAG standard was developed as a means of providing both board-level and device-level testing.

5-V or 3.3-V In-System Programming

Another benefit from the JTAG circuitry that Vantis has derived is the ability to use the JTAG port for 5-V or 3.3-V in-system programming. This allows the device to be soldered to the board before programming. Once the device is attached, the delicate Plastic Quad Flat Pack, or PQFP, leads are protected from programming and testing operations that could potentially damage them.

Programming and verification of the device is done serially, and it only requires the use of the Test Access Port. Use of the programming Enable pin (ENABLE*) is optional.

Zero-Hold-Time Input Register

The M4-256 (M4LV-256) device has a zero hold time (ZHT) fuse. This fuse controls the time delay associated with loading data into all I/O cell registers and latches in the M4-256 (M4LV-256) device.

When programmed, the ZHT fuse increases the data path setup delays to input storage elements, matching equivalent delays in the clock path. When the fuse is erased, the setup time to the input storage element is minimized.

This feature facilitates doing worst-case designs for which data is loaded from sources which have low (or zero) minimum output propagation delays from clock edges.

Power-Down Mode

Each individual PAL block in the M4-256/M4LV-256 features a programmable low-power mode, which results in power savings of up to 50%. The signal speed paths in the low-power PAL block will be slightly slower than those in the non-low-power PAL block. This feature allows speed critical signal paths to run at maximum frequency while the rest of the signal paths operate in the low-power mode.

Bus-Friendly Inputs and I/Os

The M4-256 (M4LV-256) inputs and I/Os feature the Bus-Friendly circuitry incorporating two inverters in series which loop back to the input. This double inversion weakly holds the input at its last driven logic state and pulls the voltage away from the input threshold voltage. At power-up, the Bus-Friendly latches are reset to a logic level "1." For an illustration of this configuration, please refer to the Input/Output Equivalent Schematics section.

Programmable Slew Rate

Each M4-256 (M4LV-256) I/O has an individually programmable output slew-rate control bit. Each output can be individually configured for the highest speed transition or for the lowest noise transition. In systems properly designed for high-speed applications, the fast slew-rate output option can be used to achieve the highest speed. However, the slower slew rate is more effective than the fast slew rate in keeping noise generation and ground bounce to the minimum level.

PCI Compliant

The M4-256 (M4LV-256) devices with speed grades -10 and -12 are compliant with the PCI Local Bus Specification published by the PCI Special Interest Group. The predictable timing of the M4-256 (M4LV-256) ensures compliance with the PCI timing specifications independent of the logic design fitting.

Safe for Mixed Supply Voltage System Designs

The M4-256 (M4LV-256) is safe for mixed supply voltage system designs. The 5-V device will not overdrive 3.3-V devices above the output voltage of 3.3 V, while it accepts inputs from other 3.3-V devices. The 3.3-V device will accept inputs up to 5.5 V. Thus, the M4-256 (M4LV-256) provides easy-to-use mixed-voltage design capability.

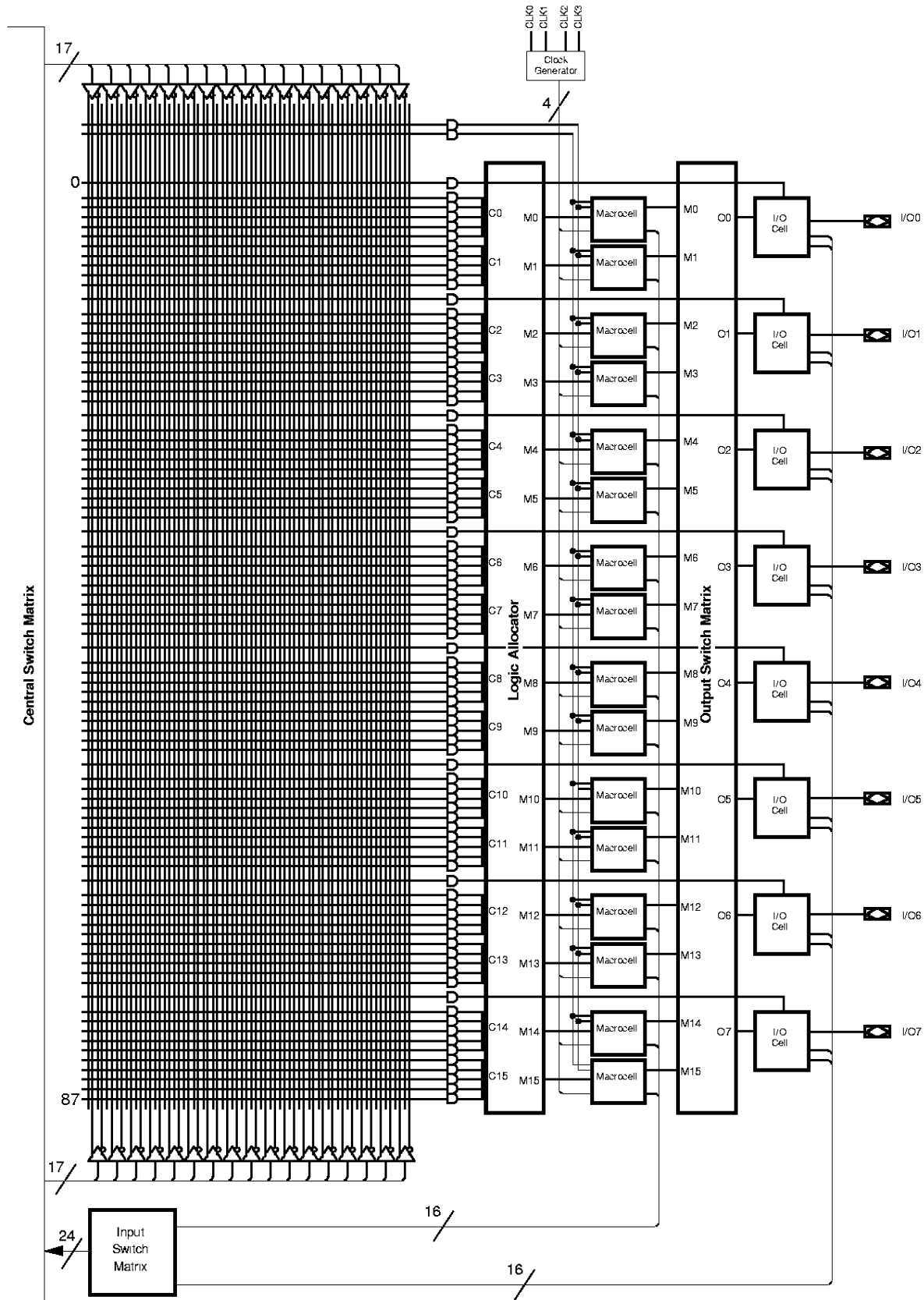

Figure 7. M4-256 (M4LV-256) PAL Block

21493A-9

ABSOLUTE MAXIMUM RATINGS

Storage Temperature	-65°C to +150°C
Ambient Temperature with Power Applied	-55°C to +100°C
Device Junction Temperature	+130°C
Supply Voltage with Respect to Ground	-0.5 V to +7.0 V
DC Input Voltage	-0.5 V to $V_{CC} + 0.5$ V
Static Discharge Voltage	2000 V
Latchup Current ($T_A = 0^\circ\text{C}$ to $+70^\circ\text{C}$)	200 mA

Stresses above those listed under Absolute Maximum Ratings may cause permanent device failure. Functionality at or above these limits is not implied. Exposure to Absolute Maximum Ratings for extended periods may affect device reliability.

OPERATING RANGES

Commercial (C) Devices

Ambient Temperature (T_A) Operating in Free Air	0°C to $+70^\circ\text{C}$
Supply Voltage (V_{CC}) with Respect to Ground	+4.75 V to +5.25 V

Operating ranges define those limits between which the functionality of the device is guaranteed.

DC CHARACTERISTICS over COMMERCIAL operating ranges

Parameter Symbol	Parameter Description	Test Conditions	Min	Typ	Max	Unit
V_{OH}	Output HIGH Voltage	$I_{OH} = -3.2$ mA, $V_{CC} = \text{Min}$ $V_{IN} = V_{IH}$ or V_{IL}	2.4		3.3	V
V_{OL}	Output LOW Voltage	$I_{OL} = 24$ mA, $V_{CC} = \text{Min}$ $V_{IN} = V_{IH}$ or V_{IL} (Note 1)			0.5	V
V_{IH}	Input HIGH Voltage	Guaranteed Input Logical HIGH Voltage for all Inputs (Note 2)	2.0			V
V_{IL}	Input LOW Voltage	Guaranteed Input Logical LOW Voltage for all Inputs (Note 2)			0.8	V
I_{IH}	Input HIGH Leakage Current	$V_{IN} = 5.25$ V, $V_{CC} = \text{Max}$ (Note 3)			10	μA
I_{IL}	Input LOW Leakage Current	$V_{IN} = 0$ V, $V_{CC} = \text{Max}$ (Note 3)			-10	μA
I_{OZH}	Off-State Output Leakage Current HIGH	$V_{OUT} = 5.25$ V, $V_{CC} = \text{Max}$ $V_{IN} = V_{IH}$ or V_{IL} (Note 3)			10	μA
I_{OZL}	Off-State Output Leakage Current LOW	$V_{OUT} = 0$ V, $V_{CC} = \text{Max}$ $V_{IN} = V_{IH}$ or V_{IL} (Note 3)			-10	μA
I_{SC}	Output Short-Circuit Current	$V_{OUT} = 0.5$ V, $V_{CC} = \text{Max}$ (Note 4)	-30		-160	mA
I_{CC}	Supply Current	All PAL Blocks low-power $V_{IN} = 0$ V, Outputs Open ($I_{OUT} = 0$ mA), $V_{CC} = 5.0$ V, $f = 1$ MHz, $T_A = 25^\circ\text{C}$ (Note 5)		100		mA
		All PAL Blocks full-power $V_{IN} = 0$ V, Outputs Open ($I_{OUT} = 0$ mA), $V_{CC} = 5.0$ V, $f = 1$ MHz, $T_A = 25^\circ\text{C}$ (Note 5)		200		mA

Notes:

1. Total I_{OL} for one PAL block should not exceed 64 mA.
2. These are absolute values with respect to device ground and all overshoots due to system or tester noise are included.
3. I/O pin leakage is the worst case of I_{IL} and I_{OZL} (or I_{IH} and I_{OZH}).
4. Not more than one output should be shorted at a time and duration of the short-circuit should not exceed one second. $V_{OUT} = 0.5$ V has been chosen to avoid test problems caused by tester ground degradation.
5. Measured with a 16-bit up/down counter pattern. This pattern is programmed in each PAL block and capable of being loaded, enabled, and reset.

CAPACITANCE (Note 1)

Parameter Symbol	Parameter Description	Test Conditions		Typ	Unit
C_{IN}	Input Capacitance	$V_{IN} = 2.0\text{ V}$	$V_{CC} = 5.0\text{ V}, T_A = 25^\circ\text{C},$ $f = 1\text{ MHz}$	6	pF
C_{OUT}	Output Capacitance	$V_{OUT} = 2.0\text{ V}$		8	pF

Note:

1. These parameters are not 100% tested, but are evaluated at initial characterization and at any time the design is modified where capacitance may be affected.

SWITCHING CHARACTERISTICS over COMMERCIAL operating ranges (Note 1)

Parameter Symbol	Parameter Description		-10		-12		-15		Unit	
			Min	Max	Min	Max	Min	Max		
t_{PD}	Input, I/O, or Feedback to Combinatorial Output		3	10	3	12	3	15	ns	
t_{SA}	Setup Time from Input, I/O, or Feedback to Product Term Clock		D-type	4		5		8	ns	
			T-type	5		6		9	ns	
t_{HA}	Register Data Hold Time Using Product Term Clock		4		5		8		ns	
t_{COA}	Product Term Clock to Output		4	12	4	14	4	18	ns	
t_{WLA}	Product Term, Clock Width		LOW	5		8		9	ns	
t_{WHA}			HIGH	5		8		9	ns	
f_{MAXA}	Maximum Frequency Using Product Term Clock (Note 2)	External Feedback	$1/(t_{SA} + t_{COA})$	D-type	62.5		52.6		38.5	MHz
			T-type	58.8		50.0		37	MHz	
		Internal Feedback (f_{CNTA})	D-type	71.4		58.8		47.6		MHz
			T-type	66.7		55.6		45.4		MHz
No Feedback (Note 3)	$1/(t_{WLA} + t_{WHA})$	100		62.5		55.6		MHz		
t_{SS}	Setup Time from Input, I/O, or Feedback to Global Clock		D-type	6		7		10	ns	
			T-type	7		8		11	ns	
t_{HS}	Register Data Hold Time Using Global Clock		0		0		0		ns	
t_{COS}	Global Clock to Output		2	6.5	2	8	2	10	ns	
t_{WLS}	Global Clock Width		LOW	5		6		6	ns	
t_{WHS}			HIGH	5		6		6	ns	
f_{MAXS}	Maximum Frequency Using Global Clock (Note 2)	External Feedback	$1/(t_{SS} + t_{COS})$	D-type	80		66.7		50	MHz
			T-type	74.1		62.5		47.6		MHz
		Internal Feedback (f_{CNTS})	D-type	100		83.3		66.6		MHz
			T-type	90.9		76.9		62.5		MHz
No Feedback (Note 3)	$1/(t_{WLS} + t_{WHS})$	100		83.3		83.3		MHz		
t_{SLA}	Setup Time from Input, I/O, or Feedback to Product Term Clock		4		5		8		ns	
t_{HLA}	Latch Data Hold Time Using Product Term Clock		4		5		8		ns	
t_{GOA}	Product Term Gate to Output			13		16		19	ns	

SWITCHING CHARACTERISTICS over COMMERCIAL operating ranges (Note 1)

Parameter Symbol	Parameter Description	-10		-12		-15		Unit	
		Min	Max	Min	Max	Min	Max		
t_{GWA}	Product Term Gate Width LOW (for LOW transparent) or HIGH (for HIGH transparent)	5		6		9		ns	
t_{SLS}	Setup Time from Input, I/O, or Feedback to Global Gate	7		8		10		ns	
t_{HLS}	Latch Data Hold Time Using Global Gate	0		0		0		ns	
t_{GOS}	Gate to Output		7.5		10		11	ns	
t_{GWS}	Global Gate Width LOW (for LOW transparent) or HIGH (for HIGH transparent)	5		6		6		ns	
t_{ICO}	Input Register Clock to Combinatorial Output		15.5		18		20	ns	
t_{ICS}	Input Register Clock to Output Register Setup	D-type	8		9		15	ns	
		T-type	9		10		16		
t_{WICL}	Input Register Clock Width	LOW	5		6		6	ns	
t_{WICH}		HIGH	5		6		6	ns	
f_{MAXIR}	Maximum Input Register Frequency	$1/(t_{WICL} + t_{WICH})$		100		83.3		83.3	MHz
t_{IGO}	Input Latch Gate to Combinatorial Output		14		16		20	ns	
t_{IGOL}	Input Latch Gate to Output Through Transparent Output Latch		16		18		22	ns	
t_{IGSA}	Input Latch Gate to Output Latch Setup Using Product Term Output Latch Gate	4		4		14		ns	
t_{IGSS}	Input Latch Gate to Output Latch Setup Using Global Output Latch Gate	9		9		16		ns	
t_{WIGL}	Input Latch Gate Width LOW	5		6		6		ns	
t_{AR}	Asynchronous Reset to Registered or Latched Output		14		16		20	ns	
t_{ARW}	Asynchronous Reset Width (Note 2)	10		12		15		ns	
t_{ARR}	Asynchronous Reset Recovery Time (Note 2)	8		10		15		ns	
t_{AP}	Asynchronous Preset to Registered or Latched Output		14		16		20	ns	
t_{APW}	Asynchronous Preset Width (Note 2)	10		12		15		ns	
t_{APR}	Asynchronous Preset Recovery Time (Note 2)	8		8		15		ns	
t_{EA}	Input, I/O, or Feedback to Output Enable	2	10	2	12	2	15	ns	
t_{ER}	Input, I/O, or Feedback to Output Disable	2	10	2	12	2	15	ns	
Input Register with Standard-Hold-Time Option									
t_{PDL}	Input, I/O, or Feedback to Output Through Transparent Input Latch		12		14		17		ns
t_{SIR}	Input Register Setup Time	2		2		2		ns	
t_{HIR}	Input Register Hold Time	3		3		4		ns	
t_{SIL}	Input Latch Setup Time	2		2		2		ns	
t_{HIL}	Input Latch Hold Time	3		3		4		ns	

Maximum Capacity

SWITCHING CHARACTERISTICS over COMMERCIAL operating ranges (Note 1)

Parameter Symbol	Parameter Description	-10		-12		-15		Unit
		Min	Max	Min	Max	Min	Max	
t_{SLLA}	Setup Time from Input, I/O, or Feedback Through Transparent Input Latch to Product Term Output Gate	4		4		4		ns
t_{SLLS}	Setup Time from Input, I/O, or Feedback Through Transparent Input Latch to Output Gate	8		9		12		ns
t_{PDLL}	Input, I/O, or Feedback to Output Through Transparent Input and Output Latches		14		16		19	ns
Input Register with Zero-Hold-Time Option								
t_{PDL}^I	Input, I/O, or Feedback to Output Through Transparent Input Latch		18		20		23	ns
t_{SIR}^I	Input Register Setup Time	6		6		6		ns
t_{HIR}^I	Input Register Hold Time	0		0		0		ns
t_{SIL}^I	Input Latch Setup Time	6		6		6		ns
t_{HIL}^I	Input Latch Hold Time	0		0		0		ns
t_{SLLA}^I	Setup Time from Input, I/O, or Feedback Through Transparent Input Latch to Product Term Output Gate	13		16		16		ns
t_{SLLS}^I	Setup Time from Input, I/O, or Feedback Through Transparent Input Latch to Output Gate	15		18		18		ns
t_{PDLL}^I	Input, I/O, or Feedback to Output Through Transparent Input and Output Latches		20		22		25	ns
Power-Down Mode and Slow Slew Rate Option								
t_{LP}	Power-down mode delay adder. For macrocells in a power-down mode PAL block, this parameter must be added to: t_{PD} , t_{COA} , t_{SS} , t_{GOA} , t_{SLS} , t_{ICO} , t_{ICS} , t_{IGO} , t_{IGOL} , t_{IGSS} , t_{AR} , t_{ARR} , t_{AP} , t_{APR} , t_{EA} , t_{ER} , t_{PDL} , t_{SLS} , t_{PDLL}		2.5		2.5		2.5	ns
t_{SLW}	Slow slew rate delay adder. For an output configured with slow slew rate option, this parameter must be added to: t_{PD} , t_{COA} , t_{COS} , t_{GOA} , t_{GOS} , t_{ICO} , t_{IGO} , t_{IGOL} , t_{AP} , t_{AR} , t_{PDL} , t_{PDLL}		2.5		2.5		2.5	ns

1. See *Switching Test Circuit* for test conditions.
2. These parameters are not 100% tested, but are evaluated at initial characterization.
3. This parameter does not apply to flip-flops in the emulated mode since the feedback path is required for emulation.

ABSOLUTE MAXIMUM RATINGS

Storage Temperature	-65°C to +150°C
Ambient Temperature with Power Applied	-55°C to +100°C
Device Junction Temperature	+130°C
Supply Voltage with Respect to Ground	-0.5 V to +4.5 V
DC Input Voltage	-0.5 V to 6.0 V
Static Discharge Voltage	2000 V
Latchup Current ($T_A = 0^\circ\text{C}$ to $+70^\circ\text{C}$)	200 mA

Stresses above those listed under Absolute Maximum Ratings may cause permanent device failure. Functionality at or above these limits is not implied. Exposure to Absolute Maximum Ratings for extended periods may affect device reliability.

OPERATING RANGES

Commercial (C) Devices

Ambient Temperature (T_A) Operating in Free Air	0°C to $+70^\circ\text{C}$
Supply Voltage (V_{CC}) with Respect to Ground	+3.0 V to +3.6 V

Operating ranges define those limits between which the functionality of the device is guaranteed.

DC CHARACTERISTICS over COMMERCIAL operating ranges

Parameter Symbol	Parameter Description	Test Conditions	Min	Typ	Max	Unit
V_{OH}	Output HIGH Voltage	$V_{CC} = \text{Min}$ $V_{IN} = V_{IH}$ or V_{IL}	$I_{OH} = -100 \mu\text{A}$	$V_{CC} - 0.2$		V
			$I_{OH} = -3.2 \text{ mA}$	2.4		V
V_{OL}	Output LOW Voltage	$V_{CC} = \text{Min}$ $V_{IN} = V_{IH}$ or V_{IL} (Note 1)	$I_{OL} = 100 \mu\text{A}$		0.2	V
			$I_{OL} = 24 \text{ mA}$		0.5	V
V_{IH}	Input HIGH Voltage	Guaranteed Input Logical HIGH Voltage for all Inputs	2.0		5.5	V
V_{IL}	Input LOW Voltage	Guaranteed Input Logical LOW Voltage for all Inputs	-0.3		0.8	V
I_{IH}	Input HIGH Leakage Current	$V_{IN} = 3.6 \text{ V}$, $V_{CC} = \text{Max}$ (Note 2)			5	μA
I_{IL}	Input LOW Leakage Current	$V_{IN} = 0 \text{ V}$, $V_{CC} = \text{Max}$ (Note 2)			-5	μA
I_{OZH}	Off-State Output Leakage Current HIGH	$V_{OUT} = 3.6 \text{ V}$, $V_{CC} = \text{Max}$ $V_{IN} = V_{IH}$ or V_{IL} (Note 2)			5	μA
I_{OZL}	Off-State Output Leakage Current LOW	$V_{OUT} = 0 \text{ V}$, $V_{CC} = \text{Max}$ $V_{IN} = V_{IH}$ or V_{IL} (Note 2)			-5	μA
I_{SC}	Output Short-Circuit Current	$V_{OUT} = 0.5 \text{ V}$, $V_{CC} = \text{Max}$ (Note 3)	-15		-160	mA
I_{CC}	Supply Current	All PAL Blocks low-power $V_{IN} = 0 \text{ V}$, Outputs Open ($I_{OUT} = 0 \text{ mA}$), $V_{CC} = 3.3 \text{ V}$, $f = 1 \text{ MHz}$, $T_A = 25^\circ\text{C}$ (Note 4)		100		mA
		All PAL Blocks full-power $V_{IN} = 0 \text{ V}$, Outputs Open ($I_{OUT} = 0 \text{ mA}$), $V_{CC} = 3.3 \text{ V}$, $f = 1 \text{ MHz}$, $T_A = 25^\circ\text{C}$ (Note 4)		200		mA

Notes:

1. Total I_{OL} for one PAL block should not exceed 64 mA.
2. I/O pin leakage is the worst case of I_{IL} and I_{OZL} (or I_{IH} and I_{OZH}).
3. Not more than one output should be shorted at a time and duration of the short-circuit should not exceed one second.
4. Measured with a 16-bit up/down counter pattern. This pattern is programmed in each PAL block and capable of being loaded, enabled, and reset.

CAPACITANCE (Note 1)

Parameter Symbol	Parameter Description	Test Conditions		Typ	Unit
C_{IN}	Input Capacitance	$V_{IN} = 2.0\text{ V}$	$V_{CC} = 3.3\text{ V}, T_A = 25^\circ\text{C},$ $f = 1\text{ MHz}$	6	pF
C_{OUT}	Output Capacitance	$V_{OUT} = 2.0\text{ V}$		8	pF

Note:

1. These parameters are not 100% tested, but are evaluated at initial characterization and at any time the design is modified where capacitance may be affected.

SWITCHING CHARACTERISTICS over COMMERCIAL operating ranges (Note 1)

Parameter Symbol	Parameter Description		-10		-12		-15		Unit	
			Min	Max	Min	Max	Min	Max		
t_{PD}	Input, I/O, or Feedback to Combinatorial Output		3	10	3	12	3	15	ns	
t_{SA}	Setup Time from Input, I/O, or Feedback to Product Term Clock		D-type	4		5		8	ns	
			T-type	5		6		9	ns	
t_{HA}	Register Data Hold Time Using Product Term Clock		4		5		8		ns	
t_{COA}	Product Term Clock to Output		4	12	4	14	4	18	ns	
t_{WLA}	Product Term, Clock Width		LOW	5		8		9	ns	
t_{WHA}			HIGH	5		8		9	ns	
f_{MAXA}	Maximum Frequency Using Product Term Clock (Note 2)	External Feedback	$1/(t_{SA} + t_{COA})$	D-type	62.5		52.6		38.5	MHz
			T-type	58.8		50.0		37	MHz	
		Internal Feedback (f_{CNTA})	D-type	71.4		58.8		47.6		MHz
			T-type	66.7		55.6		45.4		MHz
No Feedback (Note 3)	$1/(t_{WLA} + t_{WHA})$	100		62.5		55.6		MHz		
t_{SS}	Setup Time from Input, I/O, or Feedback to Global Clock		D-type	6		7		10	ns	
			T-type	7		8		11	ns	
t_{HS}	Register Data Hold Time Using Global Clock		0		0		0		ns	
t_{COS}	Global Clock to Output		2	6.5	2	8	2	10	ns	
t_{WLS}	Global Clock Width		LOW	5		6		6	ns	
t_{WHS}			HIGH	5		6		6	ns	
f_{MAXS}	Maximum Frequency Using Global Clock (Note 2)	External Feedback	$1/(t_{SS} + t_{COS})$	D-type	80		66.7		50	MHz
			T-type	74.1		62.5		47.6		MHz
		Internal Feedback (f_{CNTS})	D-type	100		83.3		66.6		MHz
			T-type	90.9		76.9		62.5		MHz
No Feedback (Note 3)	$1/(t_{WLS} + t_{WHS})$	100		83.3		83.3		MHz		
t_{SLA}	Setup Time from Input, I/O, or Feedback to Product Term Clock		4		5		8		ns	
t_{HLA}	Latch Data Hold Time Using Product Term Clock		4		5		8		ns	
t_{GOA}	Product Term Gate to Output			13		16		19	ns	

SWITCHING CHARACTERISTICS over COMMERCIAL operating ranges (Note 1)

Parameter Symbol	Parameter Description	-10		-12		-15		Unit	
		Min	Max	Min	Max	Min	Max		
t_{GWA}	Product Term Gate Width LOW (for LOW transparent) or HIGH (for HIGH transparent)	5		6		9		ns	
t_{SLS}	Setup Time from Input, I/O, or Feedback to Global Gate	7		8		10		ns	
t_{HLS}	Latch Data Hold Time Using Global Gate	0		0		0		ns	
t_{GOS}	Gate to Output		7.5		10		11	ns	
t_{GWS}	Global Gate Width LOW (for LOW transparent) or HIGH (for HIGH transparent)	5		6		6		ns	
t_{ICO}	Input Register Clock to Combinatorial Output		15.5		18		20	ns	
t_{ICS}	Input Register Clock to Output Register Setup	D-type	8		9		15	ns	
		T-type	9		10		16		
t_{WICL}	Input Register Clock Width	LOW	5		6		6	ns	
t_{WICH}		HIGH	5		6		6	ns	
f_{MAXIR}	Maximum Input Register Frequency	$1/(t_{WICL} + t_{WICH})$		100		83.3		83.3	MHz
t_{IGO}	Input Latch Gate to Combinatorial Output		14		16		20	ns	
t_{IGOL}	Input Latch Gate to Output Through Transparent Output Latch		16		18		22	ns	
t_{IGSA}	Input Latch Gate to Output Latch Setup Using Product Term Output Latch Gate	4		4		14		ns	
t_{IGSS}	Input Latch Gate to Output Latch Setup Using Global Output Latch Gate	9		9		16		ns	
t_{WIGL}	Input Latch Gate Width LOW	5		6		6		ns	
t_{AR}	Asynchronous Reset to Registered or Latched Output		14		16		20	ns	
t_{ARW}	Asynchronous Reset Width (Note 2)	10		12		15		ns	
t_{ARR}	Asynchronous Reset Recovery Time (Note 2)	8		10		15		ns	
t_{AP}	Asynchronous Preset to Registered or Latched Output		14		16		20	ns	
t_{APW}	Asynchronous Preset Width (Note 2)	10		12		15		ns	
t_{APR}	Asynchronous Preset Recovery Time (Note 2)	8		8		15		ns	
t_{EA}	Input, I/O, or Feedback to Output Enable	2	10	2	12	2	15	ns	
t_{ER}	Input, I/O, or Feedback to Output Disable	2	10	2	12	2	15	ns	
Input Register with Standard-Hold-Time Option									
t_{PDL}	Input, I/O, or Feedback to Output Through Transparent Input Latch		12		14		17	ns	
t_{SIR}	Input Register Setup Time	2		2		2		ns	
t_{HIR}	Input Register Hold Time	3		3		4		ns	
t_{SIL}	Input Latch Setup Time	2		2		2		ns	
t_{HIL}	Input Latch Hold Time	3		3		4		ns	

MACH4LV-256/128-10/12/15 (3.3-V Com'l)

SWITCHING CHARACTERISTICS over COMMERCIAL operating ranges (Note 1)

Parameter Symbol	Parameter Description	-10		-12		-15		Unit
		Min	Max	Min	Max	Min	Max	
t_{SLLA}	Setup Time from Input, I/O, or Feedback Through Transparent Input Latch to Product Term Output Gate	4		4		4		ns
t_{SLLS}	Setup Time from Input, I/O, or Feedback Through Transparent Input Latch to Output Gate	8		9		12		ns
t_{PDLL}	Input, I/O, or Feedback to Output Through Transparent Input and Output Latches		14		16		19	ns
Input Register with Zero-Hold-Time Option								
t_{PDL}^I	Input, I/O, or Feedback to Output Through Transparent Input Latch		18		20		23	ns
t_{SIR}^I	Input Register Setup Time	6		6		6		ns
t_{HIR}^I	Input Register Hold Time	0		0		0		ns
t_{SIL}^I	Input Latch Setup Time	6		6		6		ns
t_{HIL}^I	Input Latch Hold Time	0		0		0		ns
t_{SLLA}^I	Setup Time from Input, I/O, or Feedback Through Transparent Input Latch to Product Term Output Gate	13		16		16		ns
t_{SLLS}^I	Setup Time from Input, I/O, or Feedback Through Transparent Input Latch to Output Gate	15		18		18		ns
t_{PDLL}^I	Input, I/O, or Feedback to Output Through Transparent Input and Output Latches		20		22		25	ns
Power-Down Mode and Slow Slew Rate Option								
t_{LP}	Power-down mode delay adder. For macrocells in a power-down mode PAL block, this parameter must be added to: t_{PD} , t_{COA} , t_{SS} , t_{GOA} , t_{SLS} , t_{ICO} , t_{ICS} , t_{IGO} , t_{IGOL} , t_{IGSS} , t_{AR} , t_{ARR} , t_{AP} , t_{APR} , t_{EA} , t_{ER} , t_{PDL} , t_{SLS} , t_{PDLL}		2.5		2.5		2.5	ns
t_{SLW}	Slow slew rate delay adder. For an output configured with slow slew rate option, this parameter must be added to: t_{PD} , t_{COA} , t_{COS} , t_{GOA} , t_{GOS} , t_{ICO} , t_{IGO} , t_{IGOL} , t_{AP} , t_{AR} , t_{PDL} , t_{PDLL}		2.5		2.5		2.5	ns

Notes:

1. See Switching Test Circuit for test conditions.
2. These parameters are not 100% tested, but are evaluated at initial characterization.
3. This parameter does not apply to flip-flops in the emulated mode since the feedback path is required for emulation.

ABSOLUTE MAXIMUM RATINGS

Storage Temperature	-65°C to +150°C
Ambient Temperature with Power Applied	-55°C to +100°C
Device Junction Temperature	+130°C
Supply Voltage with Respect to Ground	-0.5 V to +7.0 V
DC Input Voltage	-0.5 V to $V_{CC} + 0.5$ V
Static Discharge Voltage	2000 V
Latchup Current ($T_A = -40^\circ\text{C}$ to $+85^\circ\text{C}$)	200 mA

Stresses above those listed under Absolute Maximum Ratings may cause permanent device failure. Functionality at or above these limits is not implied. Exposure to Absolute Maximum Ratings for extended periods may affect device reliability.

OPERATING RANGES

Industrial (I) Devices

Ambient Temperature (T_A) Operating in Free Air	-40°C to +85°C
Supply Voltage (V_{CC}) with Respect to Ground	+4.50 V to +5.5 V

Operating ranges define those limits between which the functionality of the device is guaranteed.

DC CHARACTERISTICS over INDUSTRIAL operating ranges

Parameter Symbol	Parameter Description	Test Conditions	Min	Typ	Max	Unit
V_{OH}	Output HIGH Voltage	$I_{OH} = -3.2$ mA, $V_{CC} = \text{Min}$ $V_{IN} = V_{IH}$ or V_{IL}	2.4		3.3	V
V_{OL}	Output LOW Voltage	$I_{OL} = 24$ mA, $V_{CC} = \text{Min}$ $V_{IN} = V_{IH}$ or V_{IL} (Note 1)			0.5	V
V_{IH}	Input HIGH Voltage	Guaranteed Input Logical HIGH Voltage for all Inputs (Note 2)	2.0			V
V_{IL}	Input LOW Voltage	Guaranteed Input Logical LOW Voltage for all Inputs (Note 2)			0.8	V
I_{IH}	Input HIGH Leakage Current	$V_{IN} = 5.25$ V, $V_{CC} = \text{Max}$ (Note 3)			10	μA
I_{IL}	Input LOW Leakage Current	$V_{IN} = 0$ V, $V_{CC} = \text{Max}$ (Note 3)			-10	μA
I_{OZH}	Off-State Output Leakage Current HIGH	$V_{OUT} = 5.25$ V, $V_{CC} = \text{Max}$ $V_{IN} = V_{IH}$ or V_{IL} (Note 3)			10	μA
I_{OZL}	Off-State Output Leakage Current LOW	$V_{OUT} = 0$ V, $V_{CC} = \text{Max}$ $V_{IN} = V_{IH}$ or V_{IL} (Note 3)			-10	μA
I_{SC}	Output Short-Circuit Current	$V_{OUT} = 0.5$ V, $V_{CC} = \text{Max}$ (Note 4)	-30		-160	mA
I_{CC}	Supply Current	All PAL Blocks low-power $V_{IN} = 0$ V, Outputs Open ($I_{OUT} = 0$ mA), $V_{CC} = 5.0$ V, $f = 1$ MHz, $T_A = 25^\circ\text{C}$ (Note 5)		100		mA
		All PAL Blocks full-power $V_{IN} = 0$ V, Outputs Open ($I_{OUT} = 0$ mA), $V_{CC} = 5.0$ V, $f = 1$ MHz, $T_A = 25^\circ\text{C}$ (Note 5)		200		mA

Notes:

- Total I_{OL} for one PAL block should not exceed 64 mA.
- These are absolute values with respect to device ground and all overshoots due to system or tester noise are included.
- I/O pin leakage is the worst case of I_{IL} and I_{OZL} (or I_{IH} and I_{OZH}).
- Not more than one output should be shorted at a time and duration of the short-circuit should not exceed one second. $V_{OUT} = 0.5$ V has been chosen to avoid test problems caused by tester ground degradation.
- Measured with a 16-bit up/down counter pattern. This pattern is programmed in each PAL block and capable of being loaded, enabled, and reset.

CAPACITANCE (Note 1)

Parameter Symbol	Parameter Description	Test Conditions		Typ	Unit
C_{IN}	Input Capacitance	$V_{IN} = 2.0\text{ V}$	$V_{CC} = 5.0\text{ V}, T_A = 25^\circ\text{C},$ $f = 1\text{ MHz}$	6	pF
C_{OUT}	Output Capacitance	$V_{OUT} = 2.0\text{ V}$		8	pF

Note:

1. These parameters are not 100% tested, but are evaluated at initial characterization and at any time the design is modified where capacitance may be affected.

SWITCHING CHARACTERISTICS over INDUSTRIAL operating ranges (Note 1)

Parameter Symbol	Parameter Description		-12		-14		-18		Unit
			Min	Max	Min	Max	Min	Max	
t_{PD}	Input, I/O, or Feedback to Combinatorial Output		3	12	3	14	3	18	ns
t_{SA}	Setup Time from Input, I/O, or Feedback to Product Term Clock	D-type	5		8		10		ns
		T-type	6		9		11		ns
t_{HA}	Register Data Hold Time Using Product Term Clock		5		8		10		ns
t_{COA}	Product Term Clock to Output		4	14	4	18	4	20	ns
t_{WLA}	Product Term, Clock Width	LOW	8		9		10		ns
t_{WHA}		HIGH	8		9		10		ns
f_{MAXA}	Maximum Frequency Using Product Term Clock (Note 2)	External Feedback	$1/(t_{SA} + t_{COA})$	D-type	52.6	38.5	33.3		MHz
				T-type	50.0	37	32.2		MHz
		Internal Feedback (f_{CNTA})		D-type	58.8	47.6	35.7		MHz
				T-type	55.6	45.4	34.4		MHz
No Feedback (Note 3)		$1/(t_{WLA} + t_{WHA})$		62.5	55.6	50.0		MHz	
t_{SS}	Setup Time from Input, I/O, or Feedback to Global Clock	D-type	7		10		12		ns
		T-type	8		11		13		ns
t_{HS}	Register Data Hold Time Using Global Clock		0		0		0		ns
t_{COS}	Global Clock to Output		2	8	2	10	2	12	ns
t_{WLS}	Global Clock Width	LOW	6		6		7		ns
t_{WHS}		HIGH	6		6		7		ns
f_{MAXS}	Maximum Frequency Using Global Clock (Note 2)	External Feedback	$1/(t_{SS} + t_{COS})$	D-type	66.7	50	41.7		MHz
				T-type	62.5	47.6	40.0		MHz
		Internal Feedback (f_{CNTS})		D-type	83.3	66.6	58.8		MHz
				T-type	76.9	62.5	55.5		MHz
No Feedback (Note 3)		$1/(t_{WLS} + t_{WHS})$		83.3	88.3	71.4		MHz	
t_{SLA}	Setup Time from Input, I/O, or Feedback to Product Term Clock		5		8		10		ns

SWITCHING CHARACTERISTICS over INDUSTRIAL operating ranges (Note 1)

Parameter Symbol	Parameter Description		-12		-14		-18		Unit
			Min	Max	Min	Max	Min	Max	
t_{HLA}	Latch Data Hold Time Using Product Term Clock		5		8		10		ns
t_{GOA}	Product Term Gate to Output			16		19		22	ns
t_{GWA}	Product Term Gate Width LOW (for LOW transparent) or HIGH (for HIGH transparent)		6		9		11		ns
t_{SLS}	Setup Time from Input, I/O, or Feedback to Global Gate		8		10		12		ns
t_{HLS}	Latch Data Hold Time Using Global Gate		0		0		0		ns
t_{GOS}	Gate to Output			10		11		12	ns
t_{GWS}	Global Gate Width LOW (for LOW transparent) or HIGH (for HIGH transparent)		6		6		7		ns
t_{ICO}	Input Register Clock to Combinatorial Output			18		20		22	ns
t_{ICS}	Input Register Clock to Output Register Setup	D-type	9		15		17		
		T-type	10		16		18		
t_{WICL}	Input Register Clock Width	LOW	6		6		7		ns
t_{WICH}		HIGH	6		6		7		ns
f_{MAXIR}	Maximum Input Register Frequency	$1/(t_{WICL} + t_{WICH})$	83.3		83.3		71.4		MHz
t_{IGO}	Input Latch Gate to Combinatorial Output			16		20		22	ns
t_{IGOL}	Input Latch Gate to Output Through Transparent Output Latch			18		22		24	ns
t_{IGSA}	Input Latch Gate to Output Latch Setup Using Product Term Output Latch Gate		4		14		16		ns
t_{IGSS}	Input Latch Gate to Output Latch Setup Using Global Output Latch Gate		9		16		18		ns
t_{WIGL}	Input Latch Gate Width LOW		6		6		7		ns
t_{AR}	Asynchronous Reset to Registered or Latched Output			16		20		22	ns
t_{ARW}	Asynchronous Reset Width (Note 2)		12		15		17		ns
t_{ARR}	Asynchronous Reset Recovery Time (Note 2)		10		15		17		ns
t_{AP}	Asynchronous Preset to Registered or Latched Output			16		20		22	ns
t_{APW}	Asynchronous Preset Width (Note 2)		12		15		17		ns
t_{APR}	Asynchronous Preset Recovery Time (Note 2)		8		15		17		ns
t_{EA}	Input, I/O, or Feedback to Output Enable		2	12	2	15	2	17	ns
t_{ER}	Input, I/O, or Feedback to Output Disable		2	12	2	15	2	17	ns
Input Register with Standard-Hold-Time Option									
t_{PDL}	Input, I/O, or Feedback to Output Through Transparent Input Latch			14		17		20	ns
t_{SIR}	Input Register Setup Time		2		2		2		ns
t_{HIR}	Input Register Hold Time		3		4		4		ns

MACH4-256/128-12/14/18 (5-V Ind)

SWITCHING CHARACTERISTICS over INDUSTRIAL operating ranges (Note 1)

Parameter Symbol	Parameter Description	-12		-14		-18		Unit
		Min	Max	Min	Max	Min	Max	
t_{SIL}	Input Latch Setup Time	2		2		2		ns
t_{HIL}	Input Latch Hold Time	3		4		4		ns
t_{SLLA}	Setup Time from Input, I/O, or Feedback Through Transparent Input Latch to Product Term Output Gate	4		4		4		ns
t_{SLLS}	Setup Time from Input, I/O, or Feedback Through Transparent Input Latch to Output Gate	9		12		15		ns
t_{PDLL}	Input, I/O, or Feedback to Output Through Transparent Input and Output Latches		16		19		22	ns
Input Register with Zero-Hold-Time Option								
t_{PDL}^I	Input, I/O, or Feedback to Output Through Transparent Input Latch		20		23		26	ns
t_{SIR}^I	Input Register Setup Time	6		6		6		ns
t_{HIR}^I	Input Register Hold Time	0		0		0		ns
t_{SIL}^I	Input Latch Setup Time	6		6		6		ns
t_{HIL}^I	Input Latch Hold Time	0		0		0		ns
t_{SLLA}^I	Setup Time from Input, I/O, or Feedback Through Transparent Input Latch to Product Term Output Gate	16		16		16		ns
t_{SLLS}^I	Setup Time from Input, I/O, or Feedback Through Transparent Input Latch to Output Gate	18		18		18		ns
t_{PDLL}^I	Input, I/O, or Feedback to Output Through Transparent Input and Output Latches		22		25		27	ns
Power-Down Mode and Slow Slew Rate Option								
t_{LP}	Power-down mode delay adder. For macrocells in a power-down mode PAL block, this parameter must be added to: t_{PD} , t_{COA} , t_{SS} , t_{GOA} , t_{SLS} , t_{ICO} , t_{ICS} , t_{IGO} , t_{IGOL} , t_{IGSS} , t_{AR} , t_{ARR} , t_{AP} , t_{APR} , t_{EA} , t_{ER} , t_{PDL} , t_{SLS} , t_{PDLL}		2.5		2.5		2.5	ns
t_{SLW}	Slow slew rate delay adder. For an output configured with slow slew rate option, this parameter must be added to: t_{PD} , t_{COA} , t_{COS} , t_{GOA} , t_{GOS} , t_{ICO} , t_{IGO} , t_{IGOL} , t_{AP} , t_{AR} , t_{PDL} , t_{PDLL}		2.5		2.5		2.5	ns

Notes:

1. See *Switching Test Circuit* for test conditions.
2. These parameters are not 100% tested, but are evaluated at initial characterization.
3. This parameter does not apply to flip-flops in the emulated mode since the feedback path is required for emulation.

ABSOLUTE MAXIMUM RATINGS

Storage Temperature	-65°C to +150°C
Ambient Temperature with Power Applied	-55°C to +100°C
Device Junction Temperature	+130°C
Supply Voltage with Respect to Ground	-0.5 V to +4.5 V
DC Input Voltage	-0.5 V to 6.0 V
Static Discharge Voltage	2000 V
Latchup Current ($T_A = -40^\circ\text{C}$ to $+85^\circ\text{C}$)	200 mA

Stresses above those listed under Absolute Maximum Ratings may cause permanent device failure. Functionality at or above these limits is not implied. Exposure to Absolute Maximum Ratings for extended periods may affect device reliability.

OPERATING RANGES

Industrial (I) Devices

Ambient Temperature (T_A) Operating in Free Air	-40°C to +85°C
Supply Voltage (V_{CC}) with Respect to Ground	+3.0 V to +3.6 V

Operating ranges define those limits between which the functionality of the device is guaranteed.

DC CHARACTERISTICS over INDUSTRIAL operating ranges

Parameter Symbol	Parameter Description	Test Conditions	Min	Typ	Max	Unit
V_{OH}	Output HIGH Voltage	$V_{CC} = \text{Min}$ $V_{IN} = V_{IH}$ or V_{IL}	$I_{OH} = -100 \mu\text{A}$	$V_{CC} - 0.2$		V
			$I_{OH} = -3.2 \text{ mA}$	2.4		V
V_{OL}	Output LOW Voltage	$V_{CC} = \text{Min}$ $V_{IN} = V_{IH}$ or V_{IL} (Note 1)	$I_{OL} = 100 \mu\text{A}$		0.2	V
			$I_{OL} = 24 \text{ mA}$		0.5	V
V_{IH}	Input HIGH Voltage	Guaranteed Input Logical HIGH Voltage for all Inputs	2.0		5.5	V
V_{IL}	Input LOW Voltage	Guaranteed Input Logical LOW Voltage for all Inputs	-0.3		0.8	V
I_{IH}	Input HIGH Leakage Current	$V_{IN} = 3.6 \text{ V}$, $V_{CC} = \text{Max}$ (Note 2)			5	μA
I_{IL}	Input LOW Leakage Current	$V_{IN} = 0 \text{ V}$, $V_{CC} = \text{Max}$ (Note 2)			-5	μA
I_{OZH}	Off-State Output Leakage Current HIGH	$V_{OUT} = 3.6 \text{ V}$, $V_{CC} = \text{Max}$ $V_{IN} = V_{IH}$ or V_{IL} (Note 2)			5	μA
I_{OZL}	Off-State Output Leakage Current LOW	$V_{OUT} = 0 \text{ V}$, $V_{CC} = \text{Max}$ $V_{IN} = V_{IH}$ or V_{IL} (Note 2)			-5	μA
I_{SC}	Output Short-Circuit Current	$V_{OUT} = 0.5 \text{ V}$, $V_{CC} = \text{Max}$ (Note 3)	-15		-160	mA
I_{CC}	Supply Current	All PAL Blocks low-power $V_{IN} = 0 \text{ V}$, Outputs Open ($I_{OUT} = 0 \text{ mA}$), $V_{CC} = 3.3 \text{ V}$, $f = 1 \text{ MHz}$, $T_A = 25^\circ\text{C}$ (Note 4)		100		mA
		All PAL Blocks full-power $V_{IN} = 0 \text{ V}$, Outputs Open ($I_{OUT} = 0 \text{ mA}$), $V_{CC} = 3.3 \text{ V}$, $f = 1 \text{ MHz}$, $T_A = 25^\circ\text{C}$ (Note 4)		200		mA

Notes:

1. Total I_{OL} for one PAL block should not exceed 64 mA.
2. I/O pin leakage is the worst case of I_{IL} and I_{OZL} (or I_{IH} and I_{OZH}).
3. Not more than one output should be shorted at a time and duration of the short-circuit should not exceed one second.
4. Measured with a 16-bit up/down counter pattern. This pattern is programmed in each PAL block and capable of being loaded, enabled, and reset.

CAPACITANCE (Note 1)

Parameter Symbol	Parameter Description	Test Conditions		Typ	Unit
C_{IN}	Input Capacitance	$V_{IN} = 2.0\text{ V}$	$V_{CC} = 3.3\text{ V}, T_A = 25^\circ\text{C},$ $f = 1\text{ MHz}$	6	pF
C_{OUT}	Output Capacitance	$V_{OUT} = 2.0\text{ V}$		8	pF

Note:

1. These parameters are not 100% tested, but are evaluated at initial characterization and at any time the design is modified where capacitance may be affected.

SWITCHING CHARACTERISTICS over INDUSTRIAL operating ranges (Note 1)

Parameter Symbol	Parameter Description		-12		-14		-18		Unit	
			Min	Max	Min	Max	Min	Max		
t_{PD}	Input, I/O, or Feedback to Combinatorial Output		3	12	3	14	3	18	ns	
t_{SA}	Setup Time from Input, I/O, or Feedback to Product Term Clock		D-type	5		8		10	ns	
			T-type	6		9		11	ns	
t_{HA}	Register Data Hold Time Using Product Term Clock		5		8		10	ns		
t_{COA}	Product Term Clock to Output		4	14	4	18	4	20	ns	
t_{WLA}	Product Term, Clock Width		LOW	8		9		10	ns	
t_{WHA}			HIGH	8		9		10	ns	
f_{MAXA}	Maximum Frequency Using Product Term Clock (Note 2)	External Feedback	$1/(t_{SA} + t_{COA})$	D-type	52.6		38.5		33.3	MHz
			T-type	50.0		37		32.2	MHz	
	Internal Feedback (f_{CNTA})		D-type	58.8		47.6		35.7	MHz	
			T-type	55.6		45.4		34.4	MHz	
No Feedback (Note 3)		$1/(t_{WLA} + t_{WHA})$	62.5		55.6		50.0	MHz		
t_{SS}	Setup Time from Input, I/O, or Feedback to Global Clock		D-type	7		10		12	ns	
			T-type	8		11		13	ns	
t_{HS}	Register Data Hold Time Using Global Clock		0		0		0	ns		
t_{COS}	Global Clock to Output		2	8	2	10	2	12	ns	
t_{WLS}	Global Clock Width		LOW	6		6		7	ns	
t_{WHS}			HIGH	6		6		7	ns	
f_{MAXS}	Maximum Frequency Using Global Clock (Note 2)	External Feedback	$1/(t_{SS} + t_{COS})$	D-type	66.7		50		41.7	MHz
			T-type	62.5		47.6		40.0	MHz	
	Internal Feedback (f_{CNTS})		D-type	83.3		66.6		58.8	MHz	
			T-type	76.9		62.5		55.5	MHz	
No Feedback (Note 2)		$1/(t_{WLS} + t_{WHS})$	83.3		88.3		71.4	MHz		
t_{SLA}	Setup Time from Input, I/O, or Feedback to Product Term Clock		5		8		10	ns		

SWITCHING CHARACTERISTICS over INDUSTRIAL operating ranges (Note 1)

Parameter Symbol	Parameter Description		-12		-14		-18		Unit
			Min	Max	Min	Max	Min	Max	
t_{HLA}	Latch Data Hold Time Using Product Term Clock		5		8		10		ns
t_{GOA}	Product Term Gate to Output			16		19		22	ns
t_{GWA}	Product Term Gate Width LOW (for LOW transparent) or HIGH (for HIGH transparent)		6		9		11		ns
t_{SLS}	Setup Time from Input, I/O, or Feedback to Global Gate		8		10		12		ns
t_{HLS}	Latch Data Hold Time Using Global Gate		0		0		0		ns
t_{GOS}	Gate to Output			10		11		12	ns
t_{GWS}	Global Gate Width LOW (for LOW transparent) or HIGH (for HIGH transparent)		6		6		7		ns
t_{ICO}	Input Register Clock to Combinatorial Output			18		20		22	ns
t_{ICS}	Input Register Clock to Output Register Setup		D-type	9		15		17	
			T-type	10		16		18	
t_{WICL}	Input Register Clock Width		LOW	6		6		7	ns
t_{WICH}			HIGH	6		6		7	ns
f_{MAXIR}	Maximum Input Register Frequency	$1/(t_{WICL} + t_{WICH})$	83.3		83.3		71.4		MHz
t_{IGO}	Input Latch Gate to Combinatorial Output			16		20		22	ns
t_{IGOL}	Input Latch Gate to Output Through Transparent Output Latch			18		22		24	ns
t_{IGSA}	Input Latch Gate to Output Latch Setup Using Product Term Output Latch Gate		4		14		16		ns
t_{IGSS}	Input Latch Gate to Output Latch Setup Using Global Output Latch Gate		9		16		18		ns
t_{WIGL}	Input Latch Gate Width LOW		6		6		7		ns
t_{AR}	Asynchronous Reset to Registered or Latched Output			16		20		22	ns
t_{ARW}	Asynchronous Reset Width (Note 2)		12		15		17		ns
t_{ARR}	Asynchronous Reset Recovery Time (Note 2)		10		15		17		ns
t_{AP}	Asynchronous Preset to Registered or Latched Output			16		20		22	ns
t_{APW}	Asynchronous Preset Width (Note 2)		12		15		17		ns
t_{APR}	Asynchronous Preset Recovery Time (Note 2)		8		15		17		ns
t_{EA}	Input, I/O, or Feedback to Output Enable		2	12	2	15	2	17	ns
t_{ER}	Input, I/O, or Feedback to Output Disable		2	12	2	15	2	17	ns
Input Register with Standard-Hold-Time Option									
t_{PDL}	Input, I/O, or Feedback to Output Through Transparent Input Latch			14		17		20	ns
t_{SIR}	Input Register Setup Time		2		2		2		ns

MACH4LV-256/128-12/14/18 (3.3-V Ind)

SWITCHING CHARACTERISTICS over INDUSTRIAL operating ranges (Note 1)

Parameter Symbol	Parameter Description	-12		-14		-18		Unit
		Min	Max	Min	Max	Min	Max	
t_{HIR}	Input Register Hold Time	3		4		4		ns
t_{SIL}	Input Latch Setup Time	2		2		2		ns
t_{HIL}	Input Latch Hold Time	3		4		4		ns
t_{SLLA}	Setup Time from Input, I/O, or Feedback Through Transparent Input Latch to Product Term Output Gate	4		4		4		ns
t_{SLLS}	Setup Time from Input, I/O, or Feedback Through Transparent Input Latch to Output Gate	9		12		15		ns
t_{PDL}	Input, I/O, or Feedback to Output Through Transparent Input and Output Latches		16		19		22	ns
Input Register with Zero-Hold-Time Option								
t_{PDL}^I	Input, I/O, or Feedback to Output Through Transparent Input Latch		20		23		26	ns
t_{SIR}^I	Input Register Setup Time	6		6		6		ns
t_{HIR}^I	Input Register Hold Time	0		0		0		ns
t_{SIL}^I	Input Latch Setup Time	6		6		6		ns
t_{HIL}^I	Input Latch Hold Time	0		0		0		ns
t_{SLLA}^I	Setup Time from Input, I/O, or Feedback Through Transparent Input Latch to Product Term Output Gate	16		16		16		ns
t_{SLLS}^I	Setup Time from Input, I/O, or Feedback Through Transparent Input Latch to Output Gate	18		18		18		ns
t_{PDL}^I	Input, I/O, or Feedback to Output Through Transparent Input and Output Latches		22		25		27	ns
Power-Down Mode and Slow Slew Rate Option								
t_{LP}	Power-down mode delay adder. For macrocells in a power-down mode PAL block, this parameter must be added to: t_{PD} , t_{COA} , t_{SS} , t_{GOA} , t_{SLS} , t_{CO} , t_{CS} , t_{GO} , t_{GOL} , t_{IGSS} , t_{AR} , t_{ARR} , t_{AP} , t_{APR} , t_{EA} , t_{ER} , t_{PDL} , t_{SLLS} , t_{PDL}		2.5		2.5		2.5	ns
t_{SLW}	Slow slew rate delay adder. For an output configured with slow slew rate option, this parameter must be added to: t_{PD} , t_{COA} , t_{COS} , t_{GOA} , t_{GOS} , t_{CO} , t_{GO} , t_{GOL} , t_{AP} , t_{AR} , t_{PDL} , t_{PDL}		2.5		2.5		2.5	ns

Notes:

1. See Switching Test Circuit for test conditions.
2. These parameters are not 100% tested, but are evaluated at initial characterization.
3. This parameter does not apply to flip-flops in the emulated mode since the feedback path is required for emulation.

TYPICAL CURRENT vs. VOLTAGE (I-V) CHARACTERISTICS

$V_{CC} = 5\text{ V or } 3.3\text{ V}, T_A = 25^\circ\text{C}$

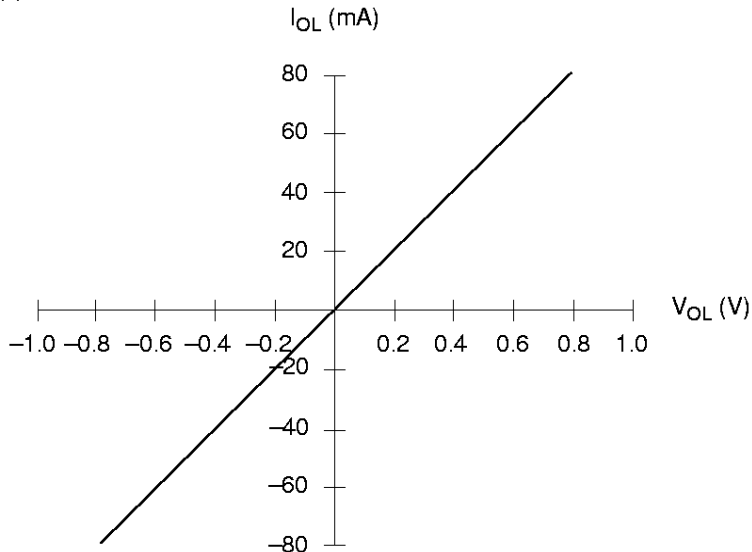

Output, LOW

21493A-10

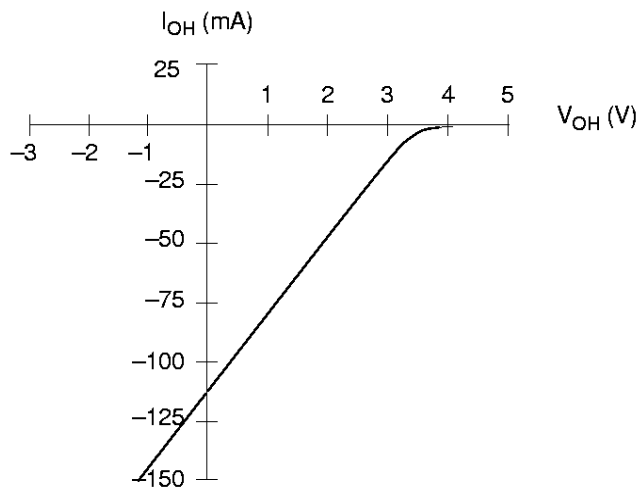

Output, HIGH

21493A-11

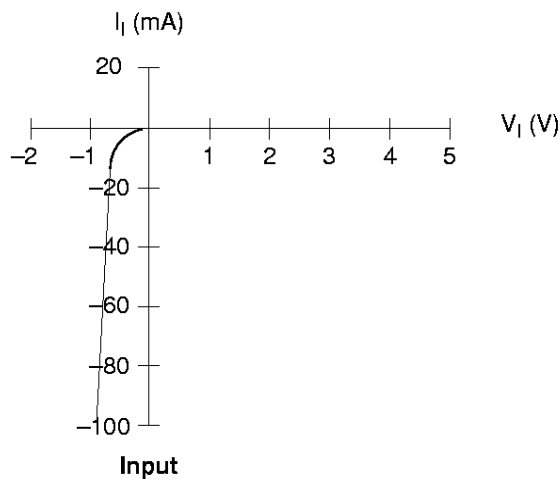

Input

21493A-12

MACH4 Family

TYPICAL I_{CC} CHARACTERISTICS

$V_{CC} = 5\text{ V OR }3.3\text{ V}$, $T_A = 25^\circ\text{C}$

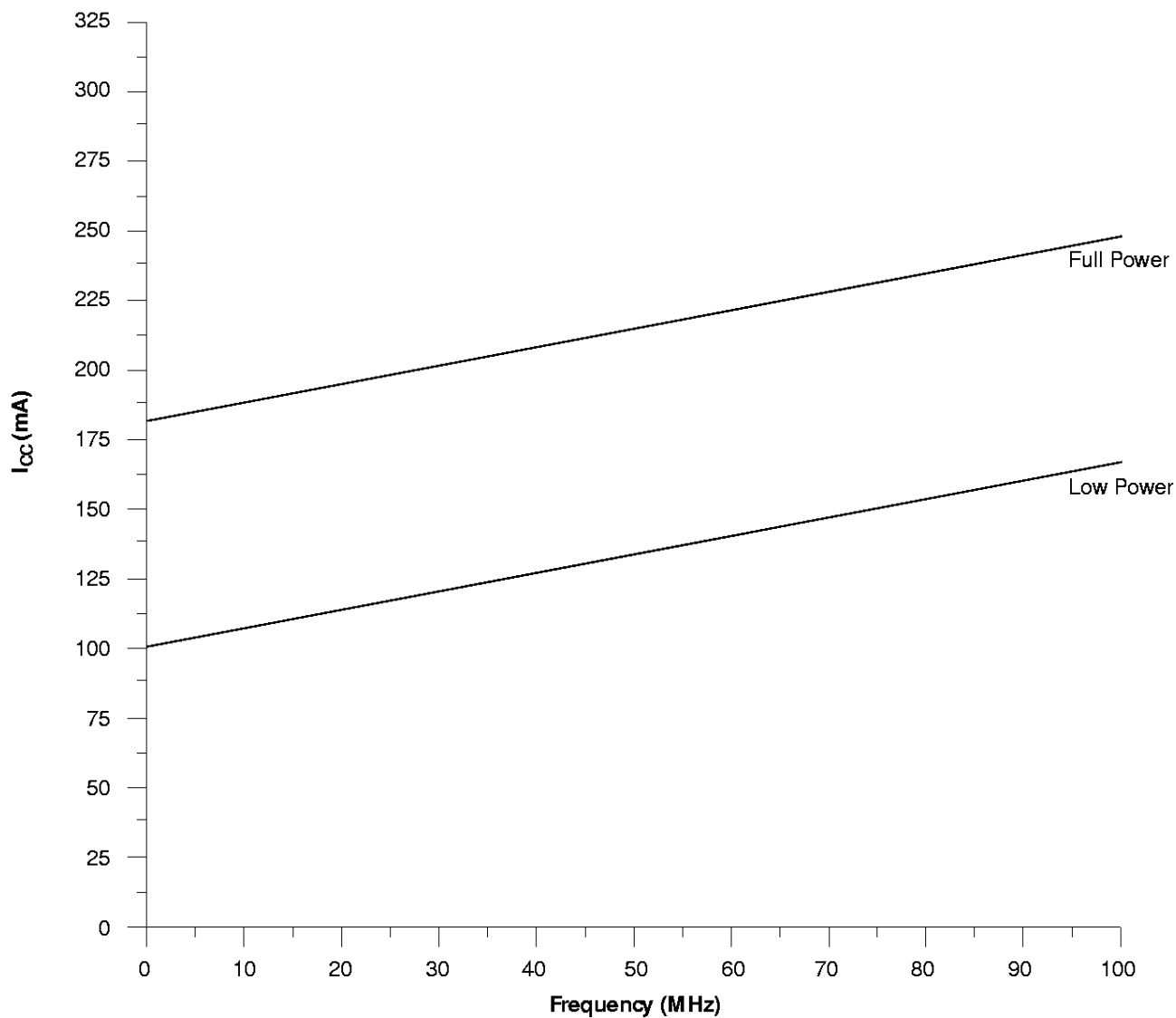

The selected "typical" pattern is a 16-bit up/down counter. This pattern is programmed in each PAL block and is capable of being loaded, enabled, and reset.

Maximum frequency shown uses internal feedback and a D-type register.

TYPICAL THERMAL CHARACTERISTICS

Measured at 25°C ambient. These parameters are not tested.

Parameter Symbol	Parameter Description	Typ	Unit	
		PQFP		
θ_{jc}	Thermal impedance, junction to case	5	°C/W	
θ_{ja}	Thermal impedance, junction to ambient	23	°C/W	
θ_{jma}	Thermal impedance, junction to ambient with air flow	200 lfm air	21	°C/W
		400 lfm air	18	°C/W
		600 lfm air	15	°C/W
		800 lfm air	14	°C/W

Plastic θ_{jc} Considerations

The data listed for plastic θ_{jc} are for reference only and are not recommended for use in calculating junction temperatures. The heat-flow paths in plastic-encapsulated devices are complex, making the θ_{jc} measurement relative to a specific location on the package surface. Tests indicate this measurement reference point is directly below the die-attach area on the bottom center of the package. Furthermore, θ_{jc} tests on packages are performed in a constant-temperature bath, keeping the package surface at a constant temperature. Therefore, the measurements can only be used in a similar environment.

SWITCHING WAVEFORMS

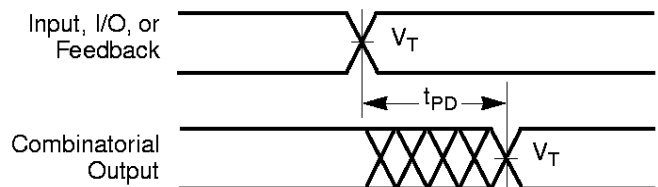

21493A-13

Combinatorial Output

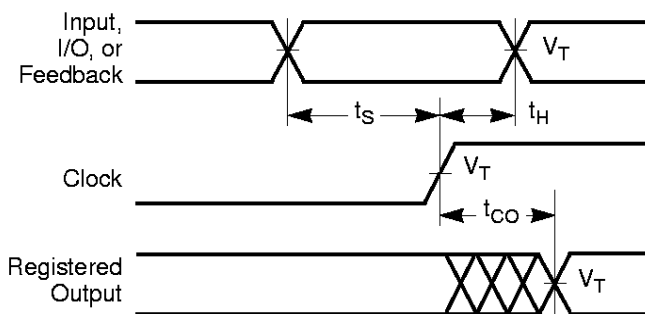

21493A-14

Registered Output

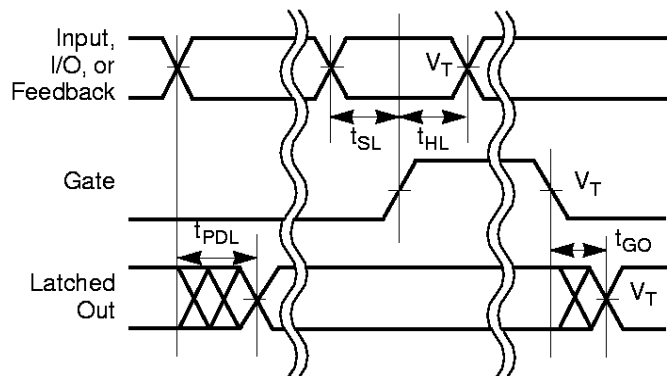

21493A-15

Latched Output

Notes:

1. $V_T = 1.5$ V.
2. Input pulse amplitude 0 V to 3.0 V.
3. Input rise and fall times 2 ns–4 ns typical.

SWITCHING WAVEFORMS

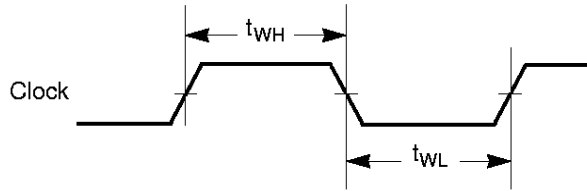

21493A-16

Clock Width

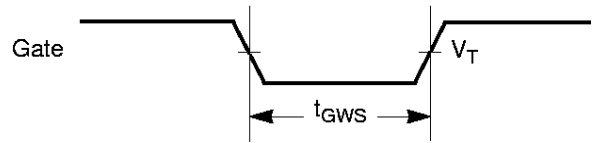

21493A-17

Gate Width

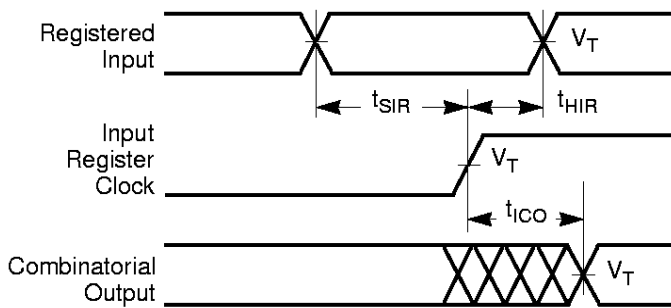

21493A-18

Registered Input

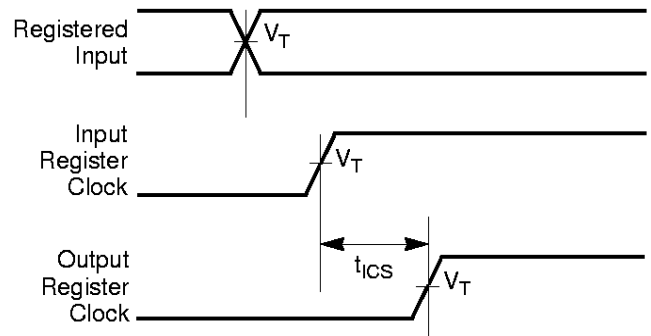

21493A-19

Input Register to Output Register Setup

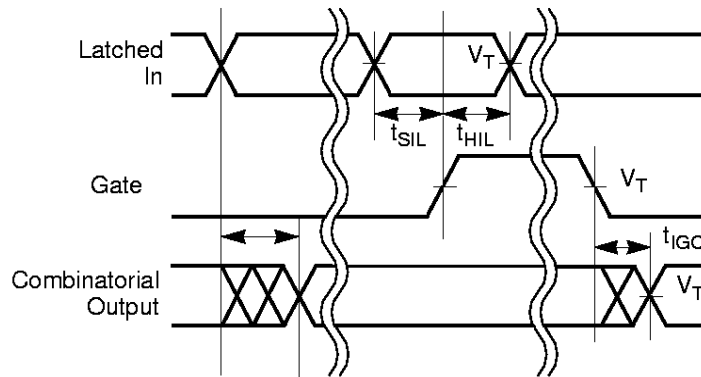

21493A-20

Latched Input

Notes:

1. $V_T = 1.5\text{ V}$.
2. Input pulse amplitude 0 V to 3.0 V.
3. Input rise and fall times 2 ns–4 ns typical.

SWITCHING WAVEFORMS

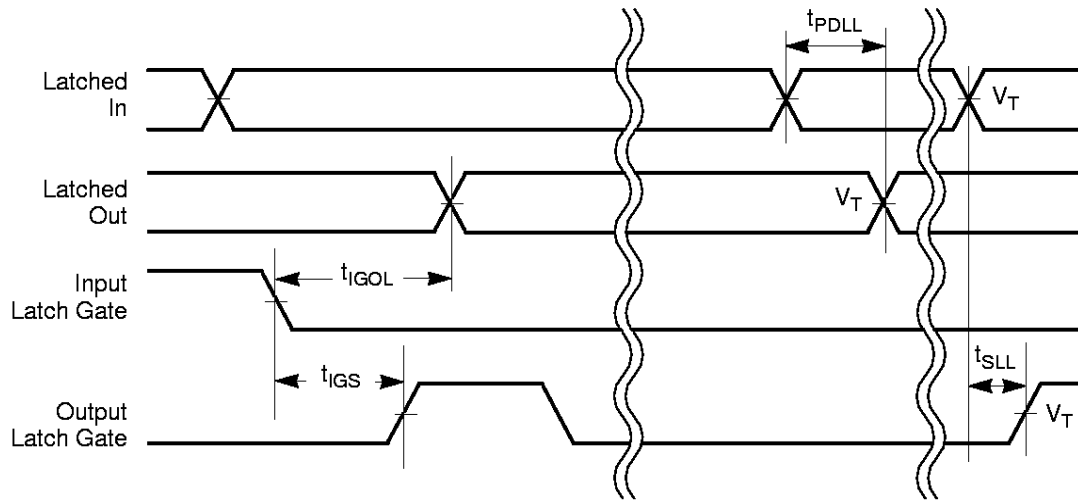

21493A-21

Latched Input and Output

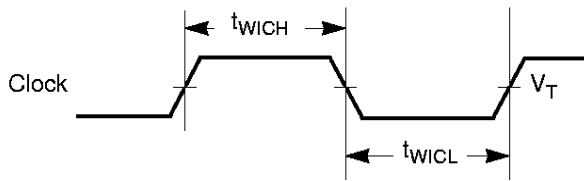

21493A-22

Input Register Clock Width

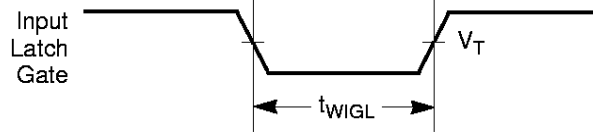

21493A-23

Input Latch Gate Width

Notes:

1. $V_T = 1.5 V$.
2. Input pulse amplitude 0 V to 3.0 V.
3. Input rise and fall times 2 ns–4 ns typical.

MACH4 Family

SWITCHING WAVEFORMS

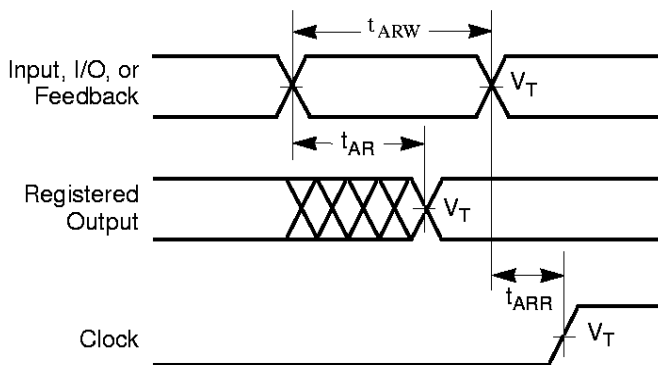

21493A-24

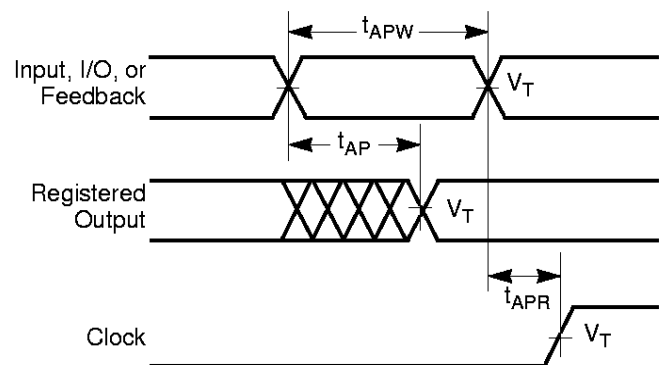
Asynchronous Reset

21493A-25

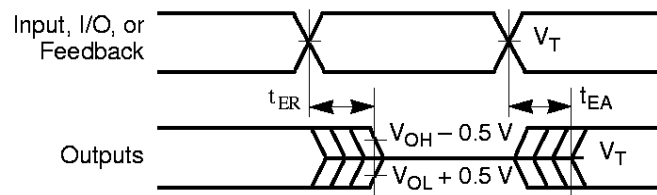



Asynchronous Preset

21493A-26

Output Disable/Enable
Notes:

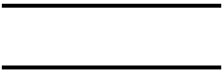
1. $V_T = 1.5\text{ V}$.
2. Input pulse amplitude 0 V to 3.0 V.
3. Input rise and fall times 2 ns–4 ns typical.

KEY TO SWITCHING WAVEFORMS

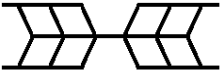
WAVEFORM	INPUTS	OUTPUTS
	Must be Steady	Will be Steady
	May Change from H to L	Will be Changing from H to L
	May Change from L to H	Will be Changing from L to H
	Don't Care, Any Change Permitted	Changing, State Unknown
	Does Not Apply	Center Line is High-Impedance "Off" State

KS000010-PAL

SWITCHING TEST CIRCUIT

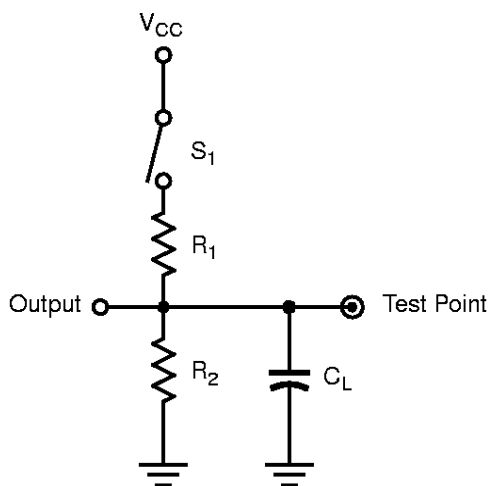

21493A-27

Specification	S ₁	C _L	Commercial		Measured Output Value
			R ₁	R ₂	
t _{PD} , t _{CO}	Closed	35 pF (30 pF)	300 Ω (1.6 K)	390 Ω (1.6 K)	1.5 V
t _{EA}	Z → H: Open Z → L: Closed				
t _{ER}	H → Z: Open L → Z: Closed	5 pF			H → Z: V _{OH} - 0.5 V L → Z: V _{OL} + 0.5 V

Values in parentheses are for 3.3-V devices

*Switching several outputs simultaneously should be avoided for accurate measurement.



f_{MAX} PARAMETERS

The parameter f_{MAX} is the maximum clock rate at which the device is guaranteed to operate. Because the flexibility inherent in programmable logic devices offers a choice of clocked flip-flop designs, f_{MAX} is specified for three types of synchronous designs.

The first type of design is a state machine with feedback signals sent off-chip. This external feedback could go back to the device inputs, or to a second device in a multi-chip state machine. The slowest path defining the period is the sum of the clock-to-output time and the input setup time for the external signals (t_S + t_{CO}). The reciprocal, f_{MAX}, is the maximum frequency with external feedback or in conjunction with an equivalent speed device. This f_{MAX} is designated “f_{MAX} external.”

The second type of design is a single-chip state machine with internal feedback only. In this case, flip-flop inputs are defined by the device inputs and flip-flop outputs. Under these conditions, the period is limited by the internal delay from the flip-flop outputs through the internal feedback and logic to the flip-flop inputs. This f_{MAX} is designated “f_{MAX} internal”. A simple internal counter is a good example of this type of design; therefore, this parameter is sometimes called “f_{CNT}.”

The third type of design is a simple data path application. In this case, input data is presented to the flip-flop and clocked through; no feedback is employed. Under these conditions, the period is limited by the sum of the data setup time and the data hold time (t_S + t_H). However, a lower limit for the period of each f_{MAX} type is the minimum clock period (t_{WH} + t_{WL}). Usually, this minimum clock period determines the period for the third f_{MAX}, designated “f_{MAX} no feedback.”

For devices with input registers, one additional f_{MAX} parameter is specified: f_{MAXIR}. Because this involves no feedback, it is calculated the same way as f_{MAX} no feedback. The minimum period will be limited either by the sum of the setup and hold times (t_{SIR} + t_{HIR}) or the sum of the clock widths (t_{WICL} + t_{WICH}). The clock widths are normally the limiting parameters, so that f_{MAXIR} is specified as 1/(t_{WICL} + t_{WICH}). Note that if both input and output registers are used in the same path, the overall frequency will be limited by t_{ICS}. All frequencies except f_{MAX} internal are calculated from other measured AC parameters. f_{MAX} internal is measured directly.

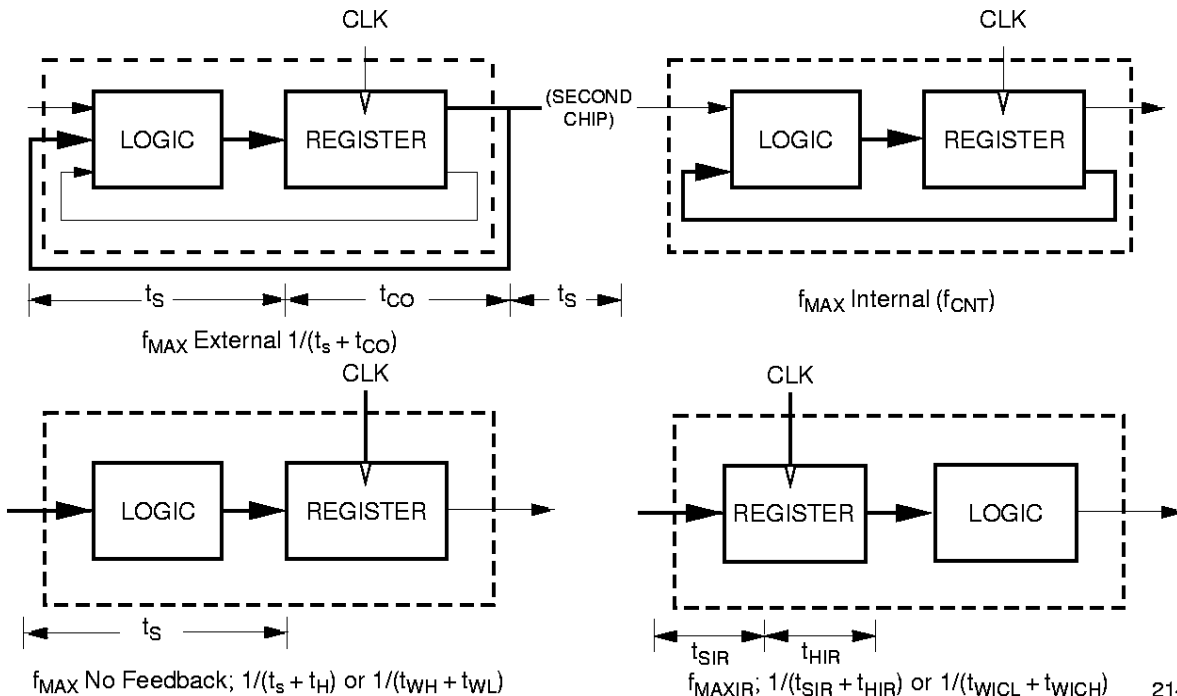

ENDURANCE CHARACTERISTICS

The MACH families are manufactured using Vantis' advanced Electrically Erasable process. This technology uses an EE cell to replace the fuse link used in bipolar parts. As a result, the device can be erased and reprogrammed, a feature which allows 100% testing at the factory.

Endurance Characteristics

Parameter Symbol	Parameter Description		Units	Test Conditions
t_{DR}	Min Pattern Data Retention Time	10	Years	Max Storage Temperature
		20	Years	Max Operating Temperature
N	Max Reprogramming Cycles	100	Cycles	Normal Programming Conditions

INPUT/ OUTPUT EQUIVALENT SCHEMATICS

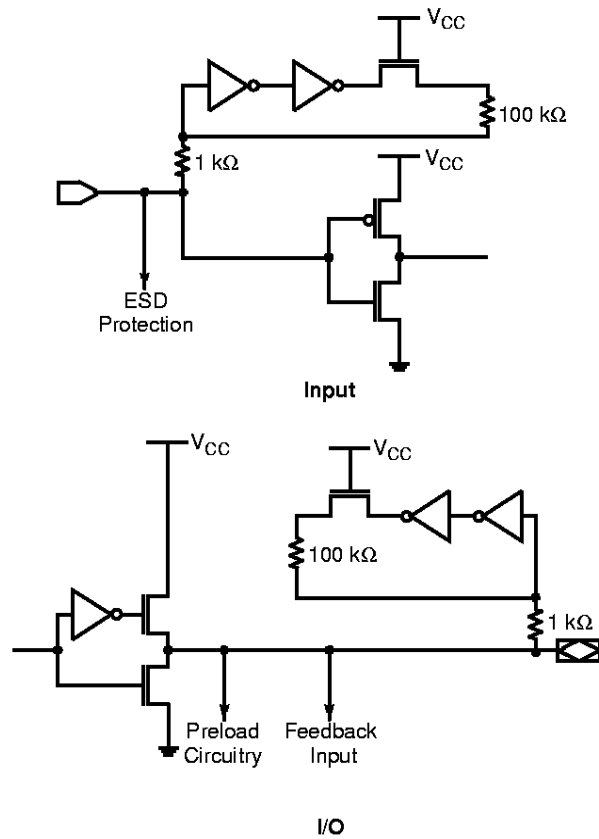

21493A-29

POWER-UP RESET

The MACH devices have been designed with the capability to reset during system power-up. Following power-up, all flip-flops will be reset to LOW. The output state will depend on the logic polarity. This feature provides extra flexibility to the designer and is especially valuable in simplifying state machine initialization. A timing diagram and parameter table are shown below. Due to the synchronous operation of the power-up reset and the wide range of ways V_{CC} can rise to its steady state, two conditions are required to insure a valid power-up reset. These conditions are:

1. The V_{CC} rise must be monotonic.
2. Following reset, the clock input must not be driven from LOW to HIGH until all applicable input and feedback setup times are met.

Parameter Symbol	Parameter Description	Max	Unit
t_{PR}	Power-Up Reset Time	10	μs
t_S	Input or Feedback Setup Time	See Switching Characteristics	
t_{WL}	Clock Width LOW		

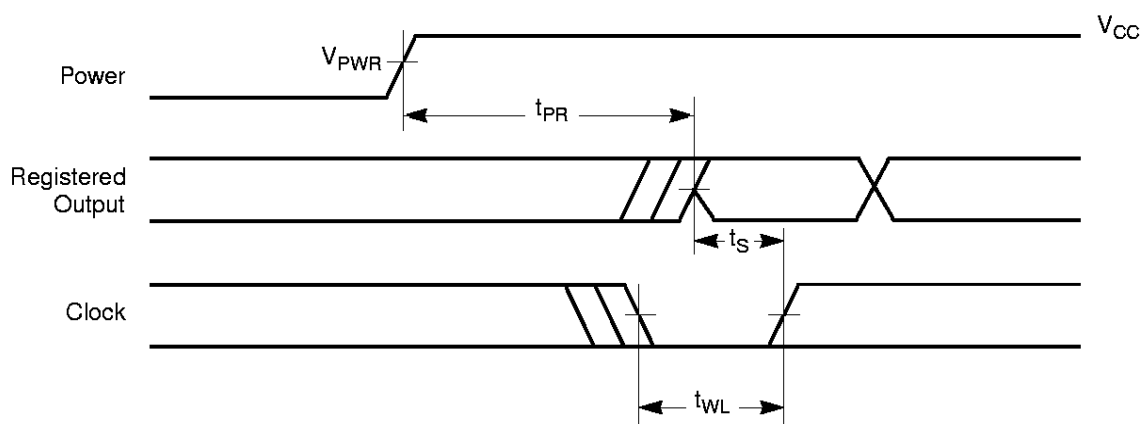

21493A-30

Power-Up Reset Waveform

$V_{PWR} = 4\text{ V}$ for 5-V devices and 2.7 V for 3.3-V devices.

DEVELOPMENT SYSTEMS (subject to change)

For more information on the products listed below, please consult the local Vantis sales office.

MANUFACTURER	SOFTWARE DEVELOPMENT SYSTEMS
Vantis Corporation P.O. Box 3755 920 DeGuigne Drive Sunnyvale, CA 94088 (408) 732-0555 or 1(888) 826-8472 (VANTIS2) http://www.vantis.com	MACHXL Software Vantis-ABEL Software Vantis-Synario Software
Aldec, Inc. 3 Sunset Way, Suite F Henderson, NV 89014 (702) 456-1222 or (800) 487-8743	ACTIVE-CAD
Cadence Design Systems 555 River Oaks Pkwy San Jose, CA 95134 (408) 943-1234 or (800) 746-6223	PIC Designer Concept/Composer Synergy Leapfrog/Verilog-XL
Exemplar Logic, Inc. 815 Atlantic Avenue, Suite 105 Alameda, CA 94501 (510) 337-3700	Leonardo™ Galileo™
Logic Modeling 19500 NW Gibbs Dr. P.O. Box 310 Beaverton, OR 97075 (800) 346-6335	SmartModel® Library
Mentor Graphics Corp. 8005 S.W. Boeckman Rd. Wilsonville, OR 97070-7777 (800) 547-3000 or (503) 685-7000	Design Architect, PLDSynthesis™ II Autologic II Synthesizer, QuickSim Simulator, QuickHDL Simulator
MicroSim Corp. 20 Fairbanks Irvine, CA 92718 (714) 770-3022	MicroSim Design Lab PLogic, PLSyn
MINC Inc. 6755 Earl Drive, Suite 200 Colorado Springs, CO 80918 (800) 755-FPGA or (719) 590-1155	PLDesigner-XL™ Software
Model Technology 8905 S.W. Nimbus Avenue, Suite 150 Beaverton, OR 97008 (503) 641-1340	V-System/VHDL
OrCAD, Inc. 9300 S.W. Nimbus Avenue Beaverton, OR 97008 (503) 671-9500 or (800) 671-9505	OrCAD Express
Synario® Design Automation 10525 Willows Road N.E. P.O. Box 97046 Redmond, WA 98073-9746 (800) 332-8246 or (206) 881-6444	ABEL™ Synario™ Software

MACH4 Series



MANUFACTURER	SOFTWARE DEVELOPMENT SYSTEMS
Synopsys 700 E. Middlefield Rd. Mountain View, CA 94040 (415) 962-5000 or (800) 388-9125	FPGA or Design Compiler (Requires MINC PLDesigner-XL™) VSS Simulator
Synplicity, Inc. 624 East Evelyn Ave. Sunnyvale, CA 94086 (408) 617-6000	Synplify
Teradyne EDA 321 Harrison Ave. Boston, MA 02118 (800) 777-2432 or (617) 422-2793	MultiSIM Interactive Simulator LASAR
VeriBest, Inc. 6101 Lookout Road, Suite A Boulder, CO 80301 (800) 837-4237	VeriBest PLD
Viewlogic Systems, Inc. 293 Boston Post Road West Marlboro, MA 01752 (800) 873-8439 or (508) 480-0881	Viewdraw, ViewPLD, Viewsynthesis Speedwave Simulator, ViewSim Simulator, VCS Simulator
MANUFACTURER	TEST GENERATION SYSTEM
Acugen Software, Inc. 427-3 Amherst St., Suite 391 Nashua, NH 03063 (603) 881-8821	ATGEN™ Test Generation Software
iNt GmbH Busenstrasse 6 D-8033 Martinsried, Munich, Germany (87) 857-6667	PLDCheck 90

Vantis is not responsible for any information relating to the products of third parties. The inclusion of such information is not a representation nor an endorsement by Vantis of these products.

APPROVED PROGRAMMERS (subject to change)

For more information on the products listed below, please consult the local Vantis sales office.

MANUFACTURER	PROGRAMMER CONFIGURATION
Advin Systems, Inc. 1050-L East Duane Ave. Sunnyvale, CA 940 86 (408) 243-7000 or (800) 627-2456 BBS (408) 737-9200 Fax (408) 736-2503	Pilot-U40 Pilot-U84 MVP
BP Microsystems 1000 N. Post Oak Rd., Suite 225 Houston, TX 77055-7237 (800) 225-2102 or (713) 688-4600 BBS (713) 688-9283 Fax (713) 688-0920	BP1200 BP1400 BP2100 BP2200
Data I/O Corporation 10525 Willows Road N.E. P.O. Box 97046 Redmond, WA 98073-9746 (800) 426-1045 or (206) 881-6444 BBS (206) 882-3211 Fax (206) 882-1043	UniSite™ Model 2900 Model 3900 AutoSite
Hi-Lo Systems 4F, No. 2, Sec. 5, Ming Shoh E. Road Taipei, Taiwan (886) 2-764-0215 Fax (886) 2-756-6403 or Tribal Microsystems / Hi-Lo Systems 44388 South Grimmer Blvd. Fremont, CA 94538 (510) 623-8859 BBS (510) 623-0430 Fax (510) 623-9925	ALL-07 FLEX-700
SMS GmbH Im Grund 15 88239 Wangen Germany (49) 7522-97280 Fax (49) 7522-972850 or SMS USA 544 Weddell Dr. Suite 12 Sunnyvale, CA 94089 (408) 542-0388	Sprint Expert Sprint Optima Multisite
Stag House Silver Court Watchmead, Welwyn Garden City Herfordshire UK AL7 1LT 44-1-707-332148 Fax 44-1-707-371503	Stag Quazar

MACH4 Series



MANUFACTURER	PROGRAMMER CONFIGURATION
System General 1603A South Main Street Milpitas, CA 95035 (408) 263-6667 BBS (408) 262-6438 Fax (408) 262-9220 or 3F, No. 1, Alley 8, Lane 45 Bao Shing Road, Shin Diau Taipei, Taiwan (886) 2-917-3005 Fax (886) 2-911-1283	Turpro-1 Turpro-1/EX Turpro-1/TX

APPROVED ADAPTER MANUFACTURERS

MANUFACTURER	PROGRAMMER CONFIGURATION
California Integration Coordinators, Inc. 656 Main Street Placerville, CA 95667 (916) 626-6168 Fax (916) 626-7740	MACH/PAL Programming Adapters
Emulation Technology, Inc. 2344 Walsh Ave., Bldg. F Santa Clara, CA 95051 (408) 982-0660 Fax (408) 982-0664	Adapt-A-Socket® Programming Adapters

APPROVED ON-BOARD ISP PROGRAMMING TOOLS

MANUFACTURER	PROGRAMMER CONFIGURATION
Corelis, Inc. 12607 Hidden Creek Way, Suite H Cerritos, California 70703 (310) 926-6727	JTAGPROG™
Vantis Corporation P.O. Box 3755 920 DeGuigne Drive Sunnyvale, CA 94088 (408) 732-0555 or 1(888) 826-8472 (VANTIS2) http://www.vantis.com	MACHPRO®

PHYSICAL DIMENSIONS

PRH208

208-Pin Plastic Quad Flat Pack; Trimmed and Formed (measured in millimeters)

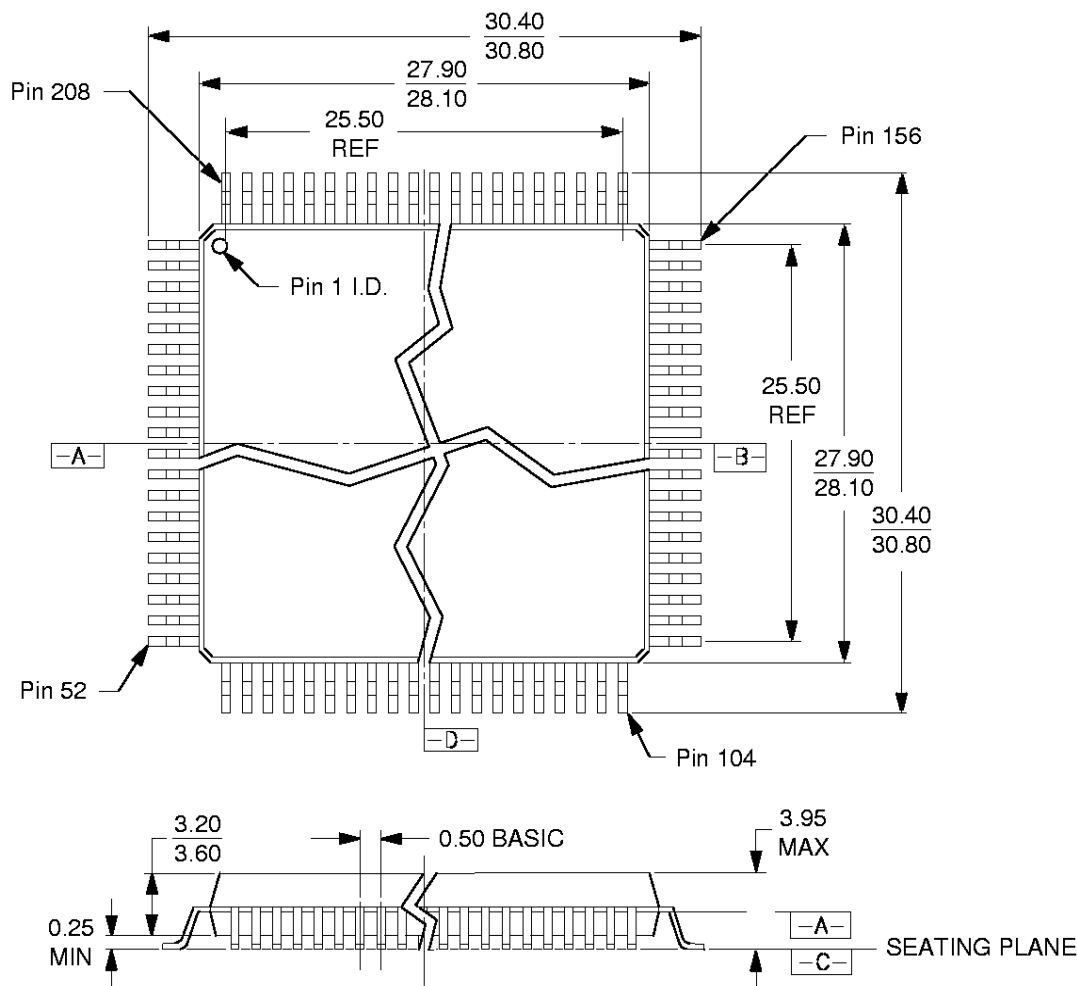

MACH4 Family

16-038-PQR-1_AH
 PRH208
 EC95
 8-6-97 lv

Trademarks

Copyright © 1997 Advanced Micro Devices, Inc. All rights reserved.

AMD, Vantis, the Vantis logo and combinations thereof, SpeedLocking and Bus-Friendly are trademarks, MACH, MACHXL, MACHPRO and PAL are registered trademarks of Advanced Micro Devices, Inc.

Product names used in this publication are for identification purposes only and may be trademarks of their respective companies.