

## 1850 – 1910 MHz High-Efficiency 3 Volt PCS Power Amplifier

TQ7641

new

The TQ7641 is a high-efficiency power amplifier developed for PCS-1900 handsets operating at the 1850 to 1910 MHz uplink band. The unit provides high-efficiency amplification of GMSK modulated signals with a saturated output power of greater than 32 dBm. It is designed for operation from a 3.4V-nominal supply and requires no externally applied negative voltage.

The TQ7641 is packaged in a small, low-cost, power TSSOP-20 plastic package. The part is designed to require minimal external circuitry for matching and bias, simplifying design and keeping board space and cost to a minimum. Power output control can be implemented using a suggested application circuit.

### Features

- 3V operation
- Single supply
- High efficiency
- 32 dBm output power
- Low harmonics
- 50-ohm matched input
- TSSOP-20 plastic package

### Applications

- PCS-1900 mobile phones

### Electrical Specifications<sup>1</sup>

Parameter <sup>2</sup>	Min	Typ	Max	Units
Output Power	+31.5	+32.7		dBm
Efficiency	37	44		%

Notes: 1. Test Conditions:  $V_{BATT} = 3.4\text{ V}$ ,  $P_{IN} = 7\text{ dBm}$ , frequency = 1880 MHz,  $V_{PC} = 2.5\text{ V}$ ,  $V_{PAON} = 3.0\text{ V}$ ,  $V_{TX} = 2.7\text{ V}$ ,  $T_C = 25^\circ\text{ C}$ .  
Pulsed:  $P_{AON}$  duty cycle = 12.5%, period = 4.6 ms.  
2. Min/max values are 100% production-tested.

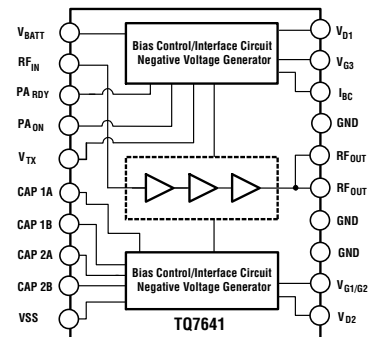

## 30 – 500-MHz IF/AGC Amplifier

TQ9114

The TQ9114 IF/AGC (Intermediate Frequency/Automatic Gain Control) Amplifier is part of TriQuint's RFIC Downconverter Building Block family. Intended for use as an Automatic Gain Control Amplifier in an IF stage, a wide range of gain control is available.

The TQ9114 provides wide-bandwidth operation from a standard +5V power supply. Its low current consumption and small, plastic surface-mount package are ideally suited for low-cost hand-held and battery-powered applications.

### Features

- 30 – 500 MHz operation
- 30 dB gain at 100 MHz
- 60 dB AGC range
- Single +5V supply
- 3.1 mA supply current
- SO-8 plastic package

### Applications

- Global Positioning Systems (GPS)
- Cellular communications
- Spread-spectrum receivers

### Electrical Specifications<sup>1</sup>

Parameter <sup>2</sup>	Min	Typ	Max	Units
Frequency of operation	30		500	MHz
Gain MHz	27	30		dB
AGC Range <sup>3</sup>	50	60		dB
DC Supply Current		3.1	4.5	mA
Gain Control Voltage <sup>4</sup>	0		5	V

Notes: 1. Test Conditions:  $V_{DD} = +5\text{ V}$ ,  $T_A = 25^\circ\text{ C}$ , frequency = 100 MHz, unless otherwise specified.  
2. Min/Max values listed are 100% production tested.  
3.  $V_{AGC} = 0\text{ V}$ , Max. Gain;  $V_{AGC} = +5\text{ V}$ , Min. Gain.  
4. Voltages which produce Min. and Max. Gain.

