

Document No.	853-1440
ECN No.	99800
Date of Issue	June 14, 1990
Status	Product Specification
ECL Products	

100124/100124A

Hex TTL-to-ECL Translator

FEATURES

- Typical propagation delay: 1.70ns
- Typical ECL supply current ($-I_{EE}$): 96mA for the 100124 and 71mA for the 100124A
- Typical TTL supply current (I_{TTL}): 44mA for the 100124 and 10mA for the 100124A

DESCRIPTION

The 100124 is a hex translator that converts TTL logic levels to 100K ECL logic levels. When the common Enable (E) is Low, all true outputs are Low, and all inverting outputs are High. The differential outputs allow each circuit to be used as an inverting, noninverting, or differential line driver.

In differential operation, common mode rejection helps overcome ground offsets

and transients between the 100124 and its receiver. V_{EE} and V_{TTL} may be applied in any order.

The 100124A is a low power version of the 100124. The only difference between the two parts are the limits of the ECL and TTL supply currents.

All unused inputs can be left open due to integrated pull-down resistors.

PIN DESCRIPTION

PINS	DESCRIPTION
$D_0 - D_5$	Data Inputs (TTL compatible)
E	Enable input (TTL compatible)
$Q_0 - Q_5$	True data outputs (100K ECL compatible)
$\bar{Q}_0 - \bar{Q}_5$	Complementary data outputs (100K ECL compatible)

ORDERING INFORMATION

DESCRIPTION	ORDER CODE
24-Pin Ceramic DIP (400 mils wide)	100124F/100124AF
24-Pin Ceramic Flat Pack	100124Y/100124AY
28-Pin PLCC	100124A/100124AA

PIN CONFIGURATIONS

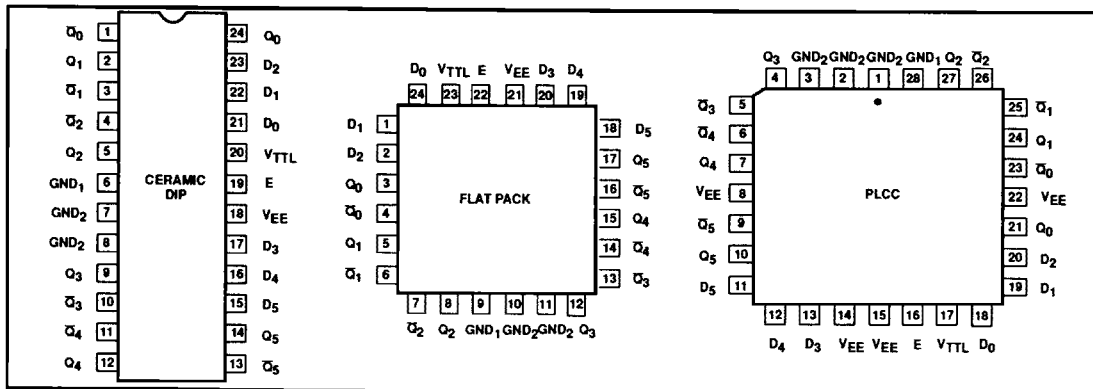

Translator

100124/100124A

IEC/IEEE SYMBOL

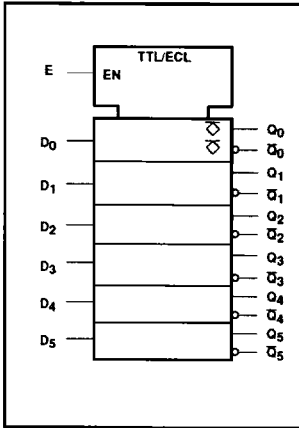

LOGIC DIAGRAM

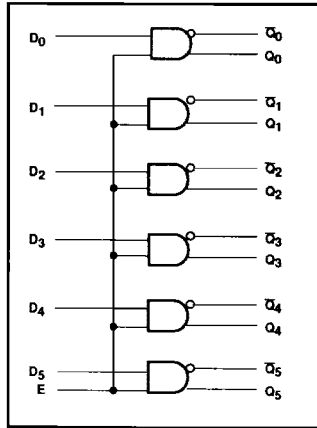

FUNCTION TABLE (One Gate)

INPUTS		OUTPUTS	
E	D _n	Q _n	\bar{Q}_n
H	H	H	L
H	L	L	H
L	X	L	H

NOTES:

- H = High voltage level
- L = Low voltage level
- X = Don't care

SIMPLIFIED SCHEMATIC

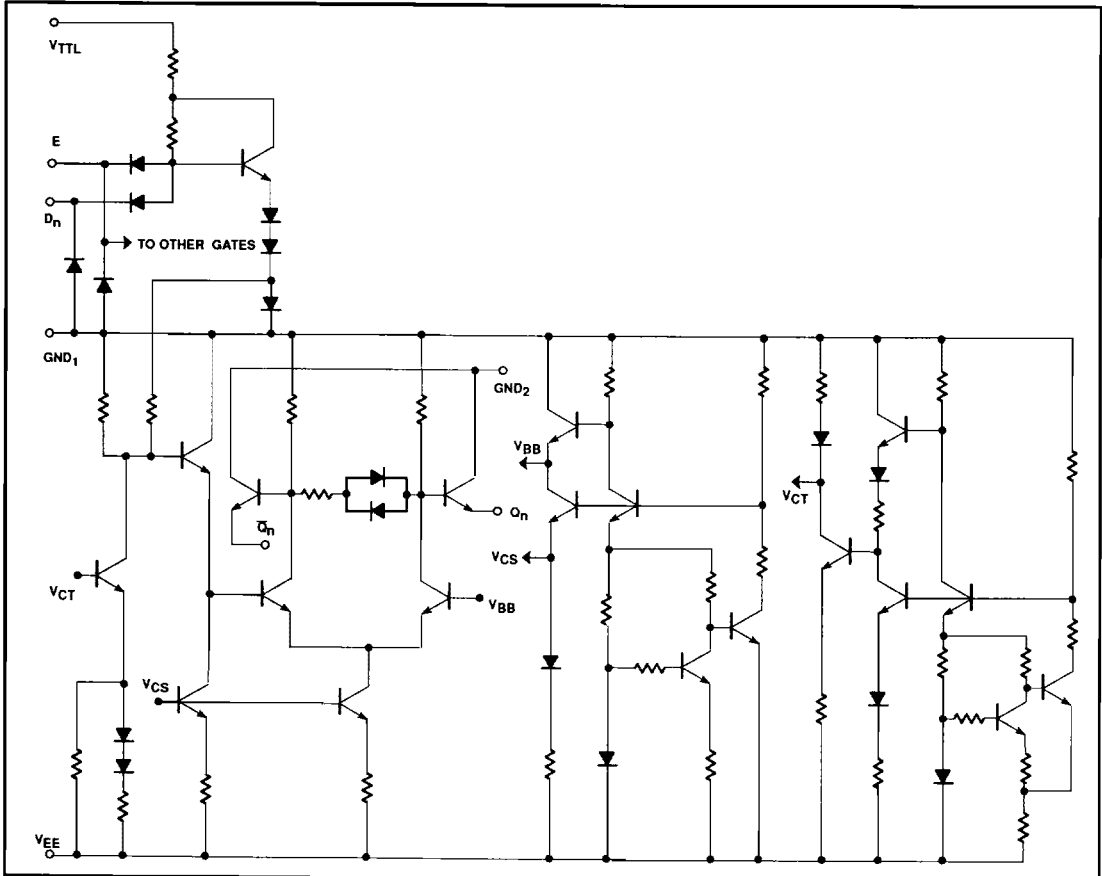

Translator

100124/100124A

ABSOLUTE MAXIMUM RATINGS $GND_1 = GND_2 = \text{ground}$, $T_A = 0^\circ\text{C}$ to $+85^\circ\text{C}$ unless otherwise specified.

SYMBOL	PARAMETER	LIMITS	UNIT
V_{TTL}	TTL Supply voltage	-0.5 to +7.0	V
V_{IN}	Input voltage	-0.5 to V_{TTL}	V
I_{IN}	Input current	-30 to +5.0	mA
V_{EE}	ECL Supply voltage	-7.0 to +0.5	V
I_O	Output source current (continuous)	-55	mA
T_S	Storage temperature range	-65 to +150	$^\circ\text{C}$
T_J	Maximum junction temperature	+150	$^\circ\text{C}$

NOTE:

Operation beyond the limits set forth in this table may impair the useful life of the device.

DC OPERATING CONDITIONS

SYMBOL	PARAMETER	LIMITS			UNIT
		MIN.	NOM.	MAX.	
GND_1, GND_2	Circuit ground	0	0	0	V
V_{TTL}	TTL Supply voltage	+4.5	+5.0	+5.5	V
V_{EE}	ECL Supply voltage	-4.8	-4.5	-4.2	V
V_{EE}	Supply voltage when operating with the 10K or the 10KH ECL family	-5.7			V
V_{IH}	High level input voltage	+2.0			V
V_{IL}	Low level input voltage			+0.8	V
T_A	Operating ambient temperature range	0	+25	+85	$^\circ\text{C}$

NOTE:When operating at other than the V_{EE} specified voltages (-4.2V, -4.5V, -4.8V), the DC and AC electrical characteristics will vary slightly from their specified values.

Translator

100124/100124A

DC ELECTRICAL CHARACTERISTICS $GND_1 = GND_2 = \text{ground}$, $V_{TTL} = 4.5\text{V to } 5.5\text{V}$, $V_{EE} = -4.8\text{V to } -4.2\text{V}$, $T_A = 0^\circ\text{C to } +85^\circ\text{C}$
 unless otherwise specified^{1,3,4}

SYMBOL	PARAMETER	TEST CONDITIONS ²			LIMITS			UNIT	
					MIN.	TYP.	MAX.		
V_{OH}	High level output voltage	Outputs Loaded with 50Ω to -2.0V $\pm 0.010\text{V}$	$E, D_n = 2.4\text{V}$, test Q_n	$V_{EE} = -4.2\text{V}$	-1020		-870	mV	
				$V_{EE} = -4.5\text{V}$	-1025	-955	-880	mV	
				$V_{EE} = -4.8\text{V}$	-1035		-880	mV	
V_{OHT}	High level output threshold voltage		$E, D_n = 2.0\text{V}$, test Q_n	$V_{EE} = -4.2\text{V}$	-1030			mV	
				$V_{EE} = -4.5\text{V}$	-1035			mV	
				$V_{EE} = -4.8\text{V}$	-1045			mV	
V_{OLT}	Low level output threshold voltage		$E, D_n = 0.8\text{V}$, test Q_n	$V_{EE} = -4.2\text{V}$			-1595	mV	
				$V_{EE} = -4.5\text{V}$			-1610	mV	
				$V_{EE} = -4.8\text{V}$			-1610	mV	
V_{OL}	Low level output voltage	$E, D_n = 0.4\text{V}$, test Q_n	$V_{EE} = -4.2\text{V}$	-1810		-1605	mV		
			$V_{EE} = -4.5\text{V}$	-1810	-1705	-1620	mV		
			$V_{EE} = -4.8\text{V}$	-1830		-1620	mV		
$-I_{EE}$	V_{EE} supply current	100124	All inputs $\geq V_{IHMIN}$			96	140	mA	
		100124A				71	90	mA	
V_{IK}	Input clamp voltage	D_n inputs	Apply -18mA to one D_n , other inputs open.			-1.5		V	
		E input	Apply -18mA to one E, other inputs open.			-1.5		V	
I_I	Input current at maximum input voltage	D_n inputs	D_n input under test $= +5.5\text{V}$, other inputs = ground.				1.0	mA	
		E input	E = $+5.5\text{V}$, other inputs = ground.				1.0	mA	
I_{IH}	High level input current	D_n inputs	D_n input under test $= +2.4\text{V}$, other inputs = ground.				20	μA	
		E input	E = $+2.4\text{V}$, other inputs = ground.				120	μA	
$-I_{IL}$	Low level input current	D_n inputs	D_n input under test $= +0.4\text{V}$, other inputs = $+2.4\text{V}$.				1.6	mA	
		E input	E = $+0.4\text{V}$, other inputs = $+2.4\text{V}$.				9.6	mA	
I_{TTL}	TTL supply current	100124	All inputs at ground.				44	75	mA
		100124A					10	15	mA

NOTES:

- The specified limits represent the worst case values for the parameter. Since these worst case values normally occur at the supply voltage and temperature extremes, additional noise immunity can be achieved by decreasing the allowable operating condition ranges.
- Conditions for testing shown in the tables are not necessarily worst case. For worst case testing guidelines, refer to DC Testing, Chapter 1, Section 3.
- The specified limits shown in the DC electrical characteristics table can be met only after thermal equilibrium has been established. Thermal equilibrium is established by applying power for at least 2 minutes, while maintaining transverse airflow of 2.5 meters/sec (500 linear feet/min) over the device, mounted either in a test socket or on a printed circuit board. Test voltage values are given in the DC operating conditions table.
- The device can function down to $V_{EE} = -5.7\text{V}$, allowing operation with either the 10K or the 10KH family. Correction factors can be used to calculate new DC limits for the extended V_{EE} range. For more information, see Chapters 5 and 10, Section 4.

Translator

100124/100124A

TRANSFER CHARACTERISTICS

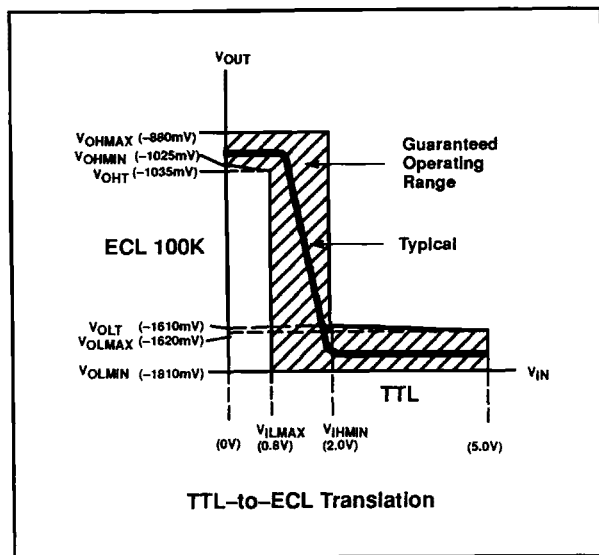

AC ELECTRICAL CHARACTERISTICS

Ceramic DIP GND₁ = GND₂ = ground, V_{TTL} = 4.5V to 5.5V, V_{EE} = -4.8V to -4.2V

SYMBOL	PARAMETER	TEST CONDITION	LIMITS						UNIT
			T _A = 0°C		T _A = +25°C		T _A = +85°C		
			MIN.	MAX.	MIN.	MAX.	MIN.	MAX.	
t _{PLH} t _{PHL}	Propagation delay D _n or E to Q _n or \bar{Q}_n	Waveform 1	0.50	3.00	0.50	2.90	0.50	3.00	ns
t _{TLH} t _{THL}	Transition time Q _n or \bar{Q}_n		0.45	1.80	0.45	1.80	0.45	1.80	ns

NOTE:

For AC test setup information, see AC Testing, Chapter 2, Section 3.

AC ELECTRICAL CHARACTERISTICS

Ceramic DIP GND₁ = GND₂ = ground, V_{TTL} = 4.5V to 5.5V, V_{EE} = -5.2V ± 5%

SYMBOL	PARAMETER	TEST CONDITION	LIMITS						UNIT
			T _A = 0°C		T _A = +25°C		T _A = +85°C		
			MIN.	MAX.	MIN.	MAX.	MIN.	MAX.	
t _{PLH} t _{PHL}	Propagation delay D _n or E to Q _n or \bar{Q}_n	Waveform 1	0.50	3.00	0.50	2.90	0.50	3.00	ns
t _{TLH} t _{THL}	Transition time Q _n or \bar{Q}_n		0.50	3.00	0.50	2.90	0.50	3.00	ns
t _{TLH} t _{THL}	Transition time Q _n or \bar{Q}_n		0.45	1.80	0.45	1.80	0.45	1.80	ns
t _{TLH} t _{THL}	Transition time Q _n or \bar{Q}_n		0.45	1.80	0.45	1.80	0.45	1.80	ns

NOTE:

For AC test setup information, see AC Testing, Chapter 2, Section 3.

Translator

100124/100124A

AC ELECTRICAL CHARACTERISTICS

Flat Pack and PLCC GND₁ = GND₂ = ground, V_{TTL} = 4.5V to 5.5V, V_{EE} = -4.8V to -4.2V

SYMBOL	PARAMETER	TEST CONDITION	LIMITS						UNIT
			T _A = 0°C		T _A = +25°C		T _A = +85°C		
			MIN.	MAX.	MIN.	MAX.	MIN.	MAX.	
t _{PLH} t _{PHL}	Propagation delay D _n or E to Q _n or \bar{Q}_n	Waveform 1	0.50 0.50	2.80 2.80	0.50 0.50	2.70 2.70	0.50 0.50	2.80 2.80	ns ns
t _{TLH} t _{THL}	Transition time Q _n or \bar{Q}_n		0.45 0.45	1.70 1.70	0.45 0.45	1.70 1.70	0.45 0.45	1.70 1.70	ns ns

NOTE:

For AC test setup information, see AC Testing, Chapter 2, Section 3.

AC ELECTRICAL CHARACTERISTICS

Flat Pack and PLCC GND₁ = GND₂ = ground, V_{TTL} = 4.5V to 5.5V, V_{EE} = -5.2V ± 5%

SYMBOL	PARAMETER	TEST CONDITION	LIMITS						UNIT
			T _A = 0°C		T _A = +25°C		T _A = +85°C		
			MIN.	MAX.	MIN.	MAX.	MIN.	MAX.	
t _{PLH} t _{PHL}	Propagation delay D _n or E to Q _n or \bar{Q}_n	Waveform 1	0.50 0.50	2.80 2.80	0.50 0.50	2.70 2.70	0.50 0.50	2.80 2.80	ns ns
t _{TLH} t _{THL}	Transition time Q _n or \bar{Q}_n		0.45 0.45	1.70 1.70	0.45 0.45	1.70 1.70	0.45 0.45	1.70 1.70	ns ns

NOTE:

For AC test setup information, see AC Testing, Chapter 2, Section 3.

AC WAVEFORMS

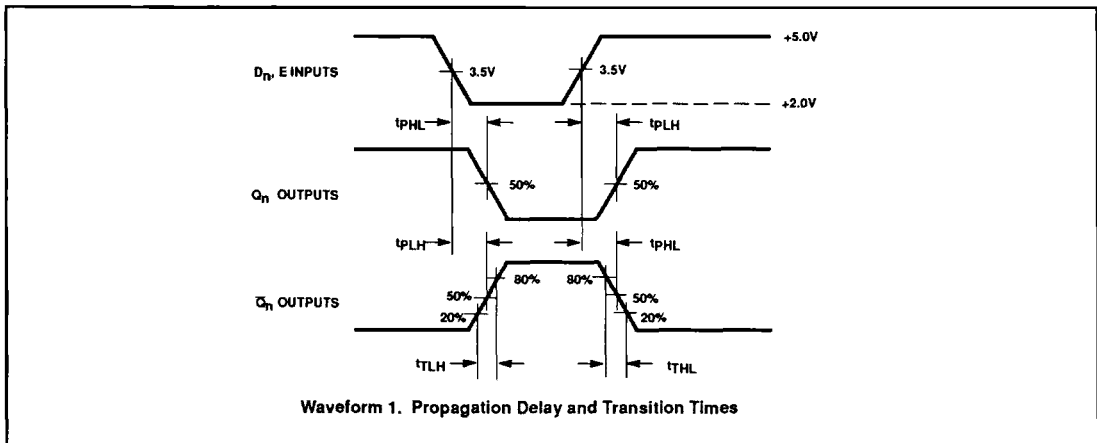

NOTE:

All power and signal voltages shifted up 2.0V for AC bench test purposes.

Translator

100124/100124A

AC TEST CIRCUIT

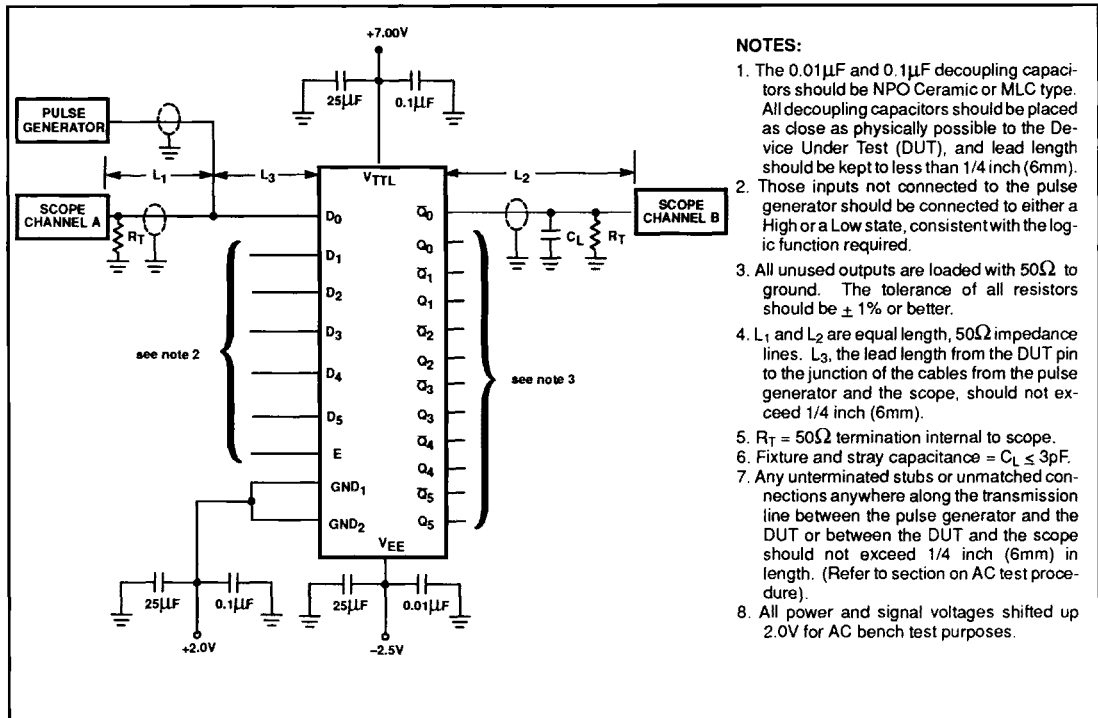

INPUT PULSE DEFINITION

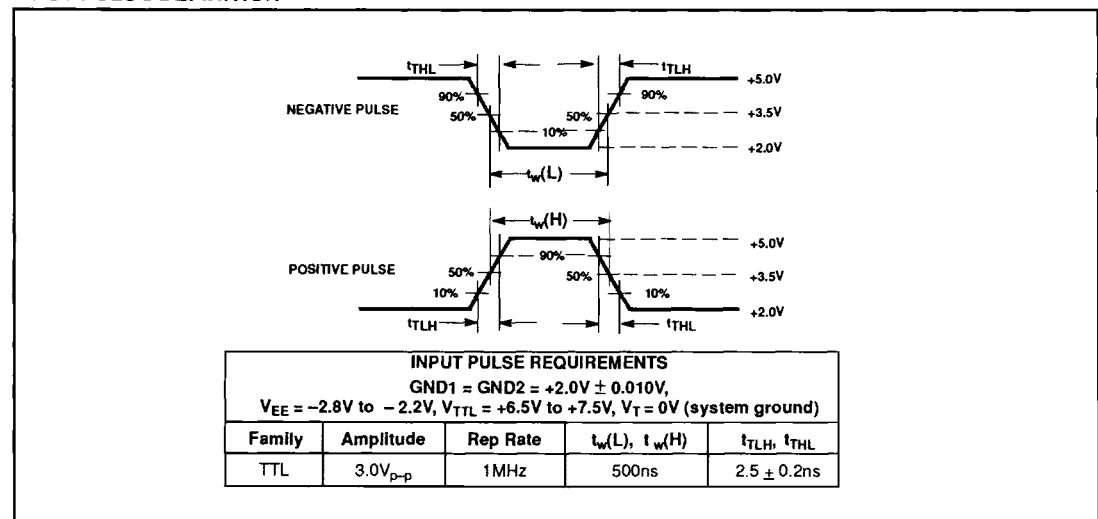

NOTE:
All power and signal voltages shifted up 2.0V for AC bench test purposes.