

TV Vertical Deflection Output Amplifier

Technology: Bipolar

Features

- Output peak current, $I_5 = 2.5 \text{ A}$
- Flyback current, peak to peak, $I_3 = 4 \text{ A}$
- Thermal protection, $T_j \geq 140^\circ\text{C}$
- **Case:** 7 leads special plastic case

Block Diagram

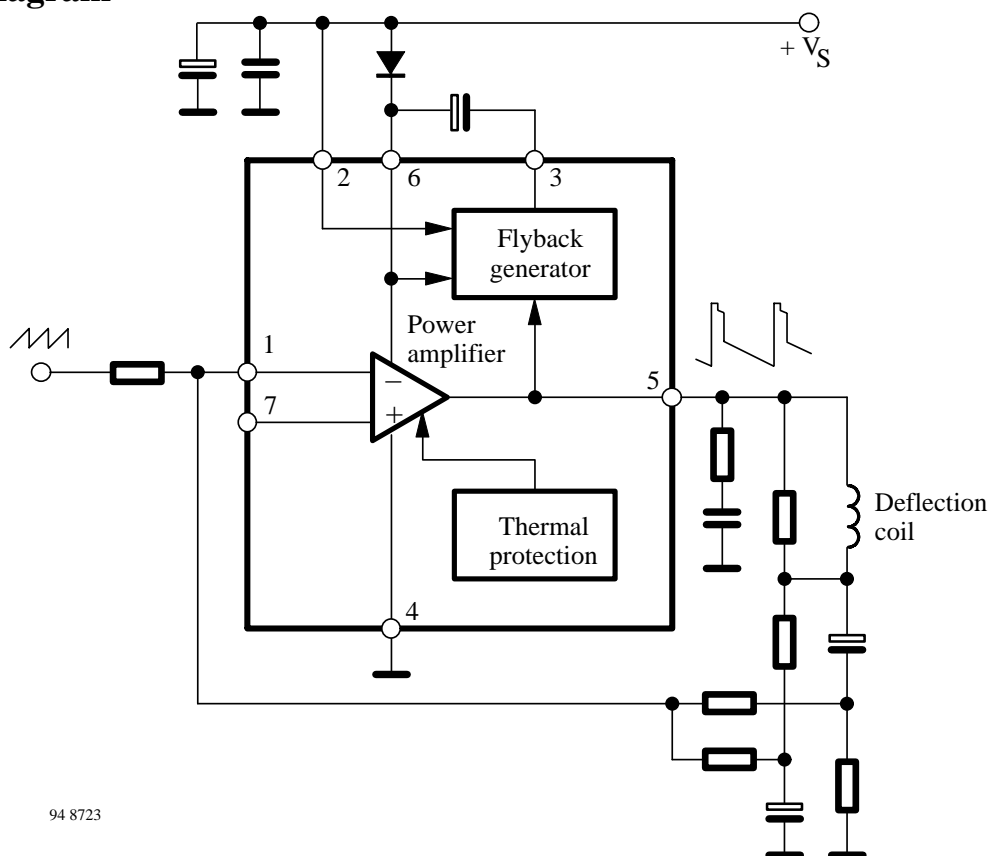

94 8723

Figure 1 Block diagram

Pin Description

Pin	Function
1	Inverted input
2	Supply voltage
3	Flyback generator
4	Ground

Pin	Function
5	Output
6	Output stage supply
7	Non inverted input

Absolute Maximum Ratings

Parameters	Symbol	Value	Unit
Supply voltage Pin 2	V_S	40	V
Flyback peak voltage Pins 5 and 6	$V_{5,6}$	70	V
Voltage at pin 3	V_3	V_S	V
Input voltage Pins 1 and 7	$V_{1,7}$	V_S	V
Output peak current: t = 2 ms, non repetitive f = 50/60 Hz, t < 10 μ s f = 50/60 Hz, t > 10 μ s Pin 5	I_O	3 3.5 2.5	A
DC current at pin 3, @ $V_5 < V_2$	I_3	100	mA
Flyback current peak to peak, f = 50/60 Hz, $t_{fly} \leq 1.5$ ms Pin 3	I_3	4	A
Power dissipation, $T_{case} = 70^\circ\text{C}$	P_{tot}	20	W
Storage temperature	T_{stg}	- 40 to + 150	$^\circ\text{C}$
Junction temperature	T_j	- 40 to + 150	$^\circ\text{C}$

Thermal Resistance

Parameters	Symbol	Maximum	Unit
Junction case	R_{thJC}	3	K/W

Electrical Characteristics

$V_S = 35$ V, $T_{amb} = 25^\circ\text{C}$, (see test circuits)

Parameters	Test Conditions / Pin	Symbol	Min	Typ	Max	Unit
Quiescent current	$I_3 = 0, I_S = 0$ Pin 2	I_2		15	20	mA
	$I_3 = 0, I_S = 0$ Pin 6 figure 2	I_6		30	45	
Input quiescent current	$V_1 = 1$ V Pin 1 figure 3	$-I_1$		0.5	1	μA
Saturation voltage to GND (Pin 4)	$I_3 = 20$ mA Pin 3 figure 4	V_{3-4}		0.5	1.1	V
Output voltage	$V_S = 35$ V, $R_f = 39$ k Ω Pin 5 figure 5	V_5		18		V
Saturation voltage to GND (Pin 4)	$I_5 = 1.2$ A Pin 5	V_{5-4}		0.35	0.7	V
	$I_5 = 2.0$ A figure 6			0.6	1.1	
Saturation voltage to supply (Pin 6)	$I_5 = -1.2$ A Pin 5 $I_5 = -2.0$ A figure 7	V_{5-6}		1 1.2	1.5 1.8	V
Junction temperature for thermal shut down		T_j		140		$^\circ\text{C}$

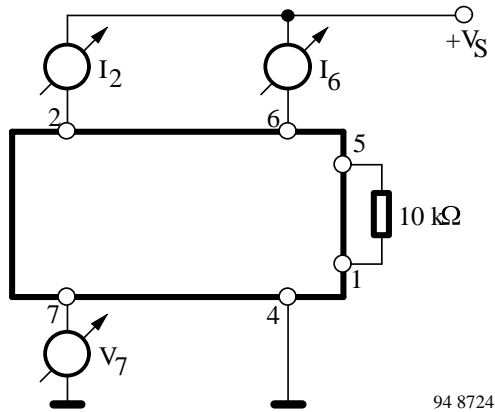

Figure 2

94 8724

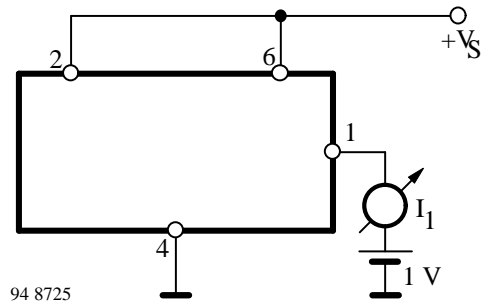

Figure 3

94 8725

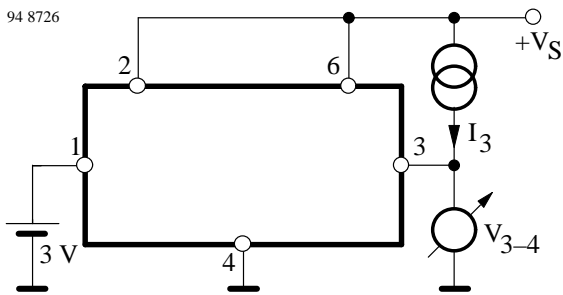

Figure 4

94 8726

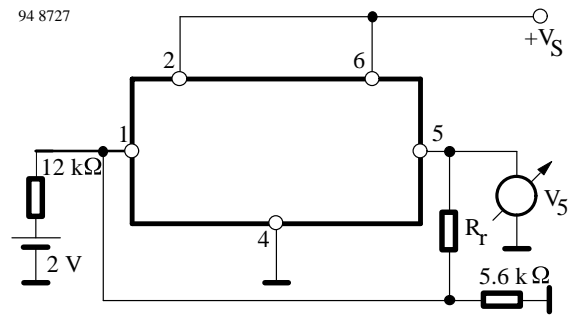

Figure 5

94 8727

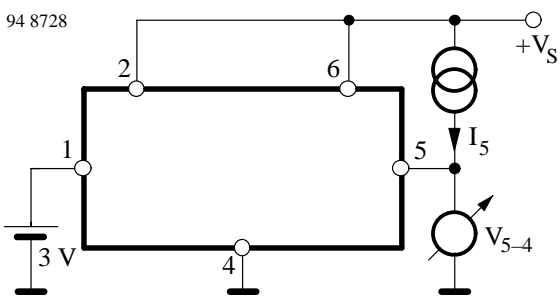

Figure 6

94 8728

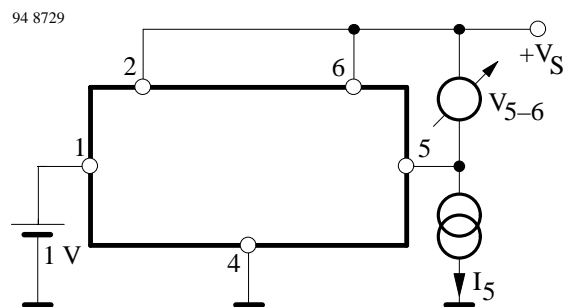
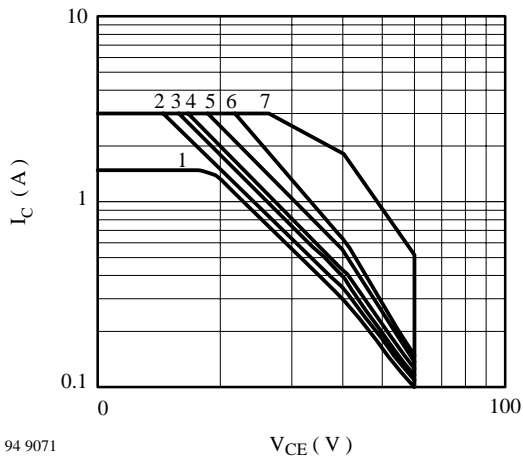

Figure 7

94 8729



Typical SOAR curves,
 $I_C = I_5, V_{CE} = V_5$ and $I_C = -I_5, V_{CE} = V_6 - V_5$

Curve no.	t_p	$t_p : T$
1	DC	
2	10 ms	1 : 2
3	10 ms	1 : 4
4	1 ms	1 : 2
5	1 ms	1 : 4
6	1 ms	1 : 20
7	0.2 ms	1 : 10

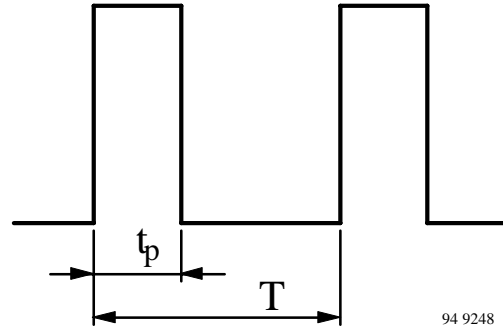

94 9248

Dimensions in mm

Package: 7 leads special plastic case

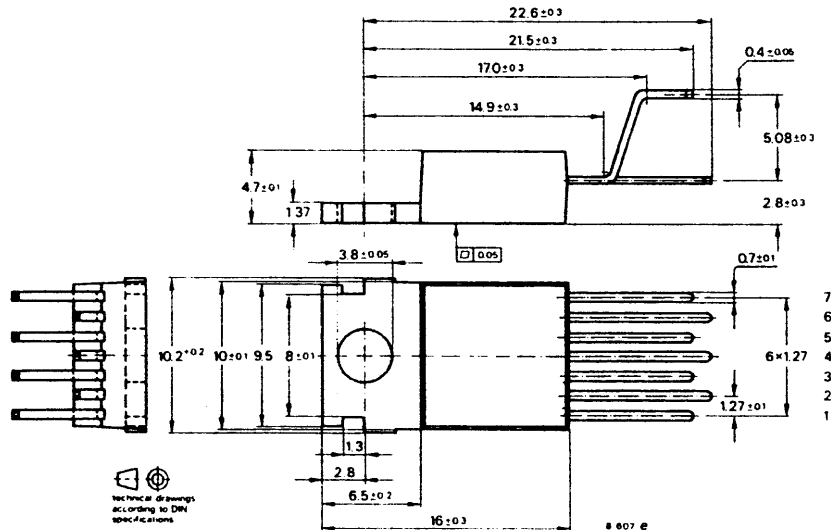

Technical drawings according to DIN specifications

607 e

Ozone Depleting Substances Policy Statement

It is the policy of **TEMIC Semiconductor GmbH** to

1. Meet all present and future national and international statutory requirements.
2. Regularly and continuously improve the performance of our products, processes, distribution and operating systems with respect to their impact on the health and safety of our employees and the public, as well as their impact on the environment.

It is particular concern to control or eliminate releases of those substances into the atmosphere which are known as ozone depleting substances (ODSs).

The Montreal Protocol (1987) and its London Amendments (1990) intend to severely restrict the use of ODSs and forbid their use within the next ten years. Various national and international initiatives are pressing for an earlier ban on these substances.

TEMIC Semiconductor GmbH semiconductor division has been able to use its policy of continuous improvements to eliminate the use of ODSs listed in the following documents.

1. Annex A, B and list of transitional substances of the Montreal Protocol and the London Amendments respectively
2. Class I and II ozone depleting substances in the Clean Air Act Amendments of 1990 by the Environmental Protection Agency (EPA) in the USA
3. Council Decision 88/540/EEC and 91/690/EEC Annex A, B and C (transitional substances) respectively.

TEMIC Semiconductor GmbH can certify that our semiconductors are not manufactured with ozone depleting substances and do not contain such substances.

We reserve the right to make changes to improve technical design and may do so without further notice.

Parameters can vary in different applications. All operating parameters must be validated for each customer application by the customer. Should the buyer use TEMIC Semiconductors products for any unintended or unauthorized application, the buyer shall indemnify TEMIC Semiconductors against all claims, costs, damages, and expenses, arising out of, directly or indirectly, any claim of personal damage, injury or death associated with such unintended or unauthorized use.

TEMIC Semiconductor GmbH, P.O.B. 3535, D-74025 Heilbronn, Germany
Telephone: 49 (0)7131 67 2594, Fax number: 49 (0)7131 67 2423