

**1 310 nm FOR 156 Mb/s, 622 Mb/s, 1.25 Gb/s, FTTH  
InGaAsP MQW-FP LASER DIODE****DESCRIPTION**

The NX5310 Series is a 1 310 nm Multiple Quantum Well (MQW) structured Fabry-Perot (FP) laser diode with InGaAs monitor PIN-PD. These devices are designed for application up to 1.25 Gb/s.

**APPLICATIONS**

- STM-1 (I-1, S-1.1), STM-4 (I-4, S-4.1), ITU-T recommendations
- FTTH P2P (Fiber To The Home Point to Point) system

**FEATURES**

- Optical output power  $P_o = 5.0 \text{ mW}$
- Low threshold current  $I_{th} = 6 \text{ mA}$
- Differential efficiency  $\eta_d = 0.3 \text{ W/A}$
- Wide operating temperature range  $T_c = -40 \text{ to } +85^\circ\text{C}$
- InGaAs monitor PIN-PD
- CAN package  $\phi 5.6 \text{ mm}$
- Fiber coupling point  $5.8 \text{ mm}$



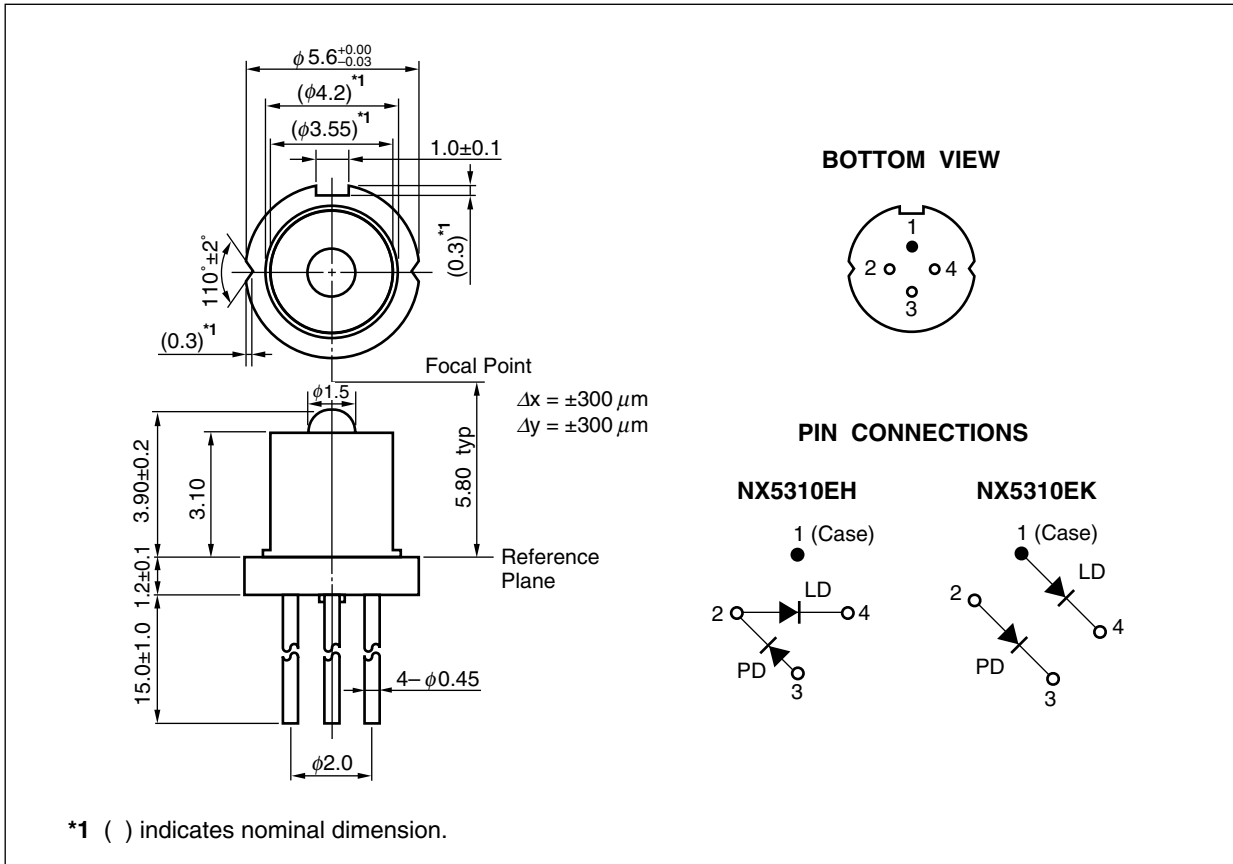

The information in this document is subject to change without notice. Before using this document, please confirm that this is the latest version.  
Not all products and/or types are available in every country. Please check with an NEC Electronics sales representative for availability and additional information.

<R> PACKAGE DIMENSIONS (UNIT: mm)

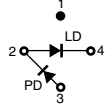

**ORDERING INFORMATION**

Part Number	Package	Pin Connections
NX5310EH	4-pin CAN with ball lens cap	 <p>Diagram showing pin connections for NX5310EH. Pin 1 is at the top, pin 2 on the left, pin 3 at the bottom, and pin 4 on the right. Pin 1 is connected to LD (Laser Diode) and pin 4. Pin 2 is connected to PD (Photodiode) and pin 3.</p>
NX5310EK		 <p>Diagram showing pin connections for NX5310EK. Pin 1 is at the top, pin 2 on the left, pin 3 at the bottom, and pin 4 on the right. Pin 1 is connected to LD (Laser Diode) and pin 4. Pin 2 is connected to PD (Photodiode) and pin 3.</p>

**Remark** The hermetic test will be performed as AQL 1.0%.

**ABSOLUTE MAXIMUM RATINGS**

Parameter	Symbol	Ratings	Unit
Optical Output Power	$P_o$	10	mW
Forward Current of LD	$I_F$	150	mA
Reverse Voltage of LD	$V_R$	2.0	V
Forward Current of PD	$I_F$	10	mA
Reverse Voltage of PD	$V_R$	20	V
Operating Case Temperature	$T_c$	-40 to +85	°C
Storage Temperature	$T_{stg}$	-40 to +85	°C
Assembly Temperature	$T_{asb}$	150 (15 Hr)	°C
Lead Soldering Temperature	$T_{slid}$	350 (3 sec.)	°C
Relative Humidity (noncondensing)	RH	85	%

**ELECTRO-OPTICAL CHARACTERISTICS ( $T_c = 25^\circ\text{C}$ , unless otherwise specified)**

Parameter	Symbol	Conditions	MIN.	TYP.	MAX.	Unit
Operating Voltage	$V_{op}$	$P_o = 5.0 \text{ mW}$		1.1	1.5	V
Operating Current	$I_{op}$	$P_o = 5.0 \text{ mW}$	10	20	35	mA
Threshold Current	$I_{th}$		3	6	15	mA
Differential Efficiency	$\eta_d$		0.2	0.3	0.7	W/A
Center Wavelength	$\lambda_c$	$P_o = 5.0 \text{ mW, RMS } (-20 \text{ dB})$	1 290	1 310	1 330	nm
Spectral Width	$\sigma$	$P_o = 5.0 \text{ mW, RMS } (-20 \text{ dB})$		1.0	2.0	nm
Rise Time	$t_r$	10-90%		0.15	0.3	ns
Fall Time	$t_f$	90-10%		0.15	0.3	ns
Lateral Beam Angle	$\theta_l$	$P_o = 5.0 \text{ mW}$		11		deg.
Vertical Beam Angle	$\theta_v$	$P_o = 5.0 \text{ mW}$		11		deg.
Monitor Current	$I_m$	$V_R = 1.5 \text{ V, } P_o = 5.0 \text{ mW}$	100	500	900	$\mu\text{A}$
Monitor Dark Current	$I_D$	$V_R = 10 \text{ V}$			100	nA
Monitor PD Terminal Capacitance	$C_t$	$V_R = 10 \text{ V, } f = 1 \text{ MHz}$			20	pF
Focal Distance	$D_f$	$P_o = 5.0 \text{ mW}$	5.0	5.8	6.2	mm
Optical Output Power from Fiber	$P_f$	$P_o = 5.0 \text{ mW, 8 degree angled fiber, Optimized X, Y, } \theta, Z = 5.8 \pm 0.05 \text{ mm.}$	400	800		$\mu\text{W}$

<R> **TYPICAL CHARACTERISTICS (T<sub>c</sub> = -40 to +85°C, unless otherwise specified)**

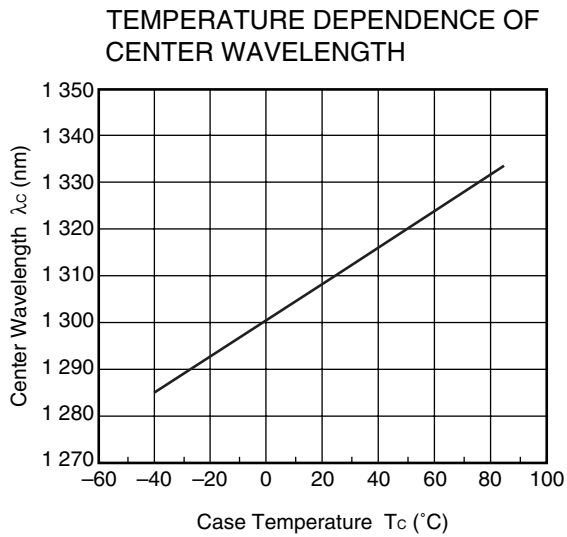
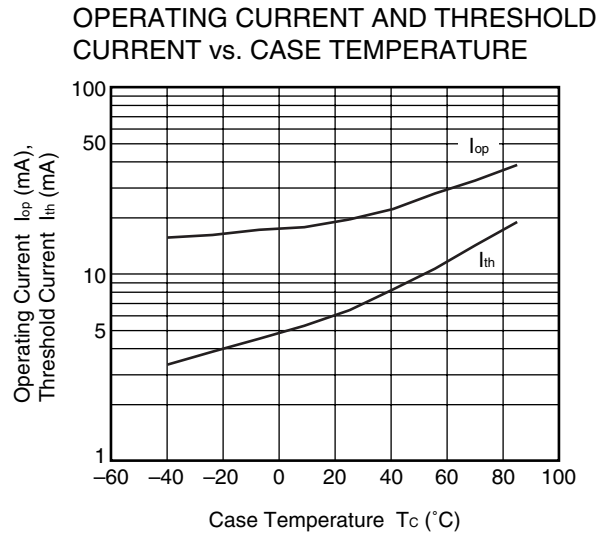
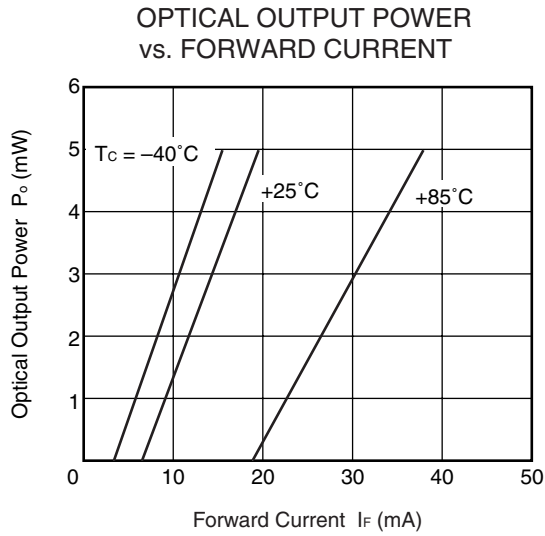

**Remark** The graphs indicate nominal characteristics.

<R> **TYPICAL CHARACTERISTICS (T<sub>c</sub> = 25°C, unless otherwise specified)**

**FORWARD CURRENT vs. FORWARD VOLTAGE**

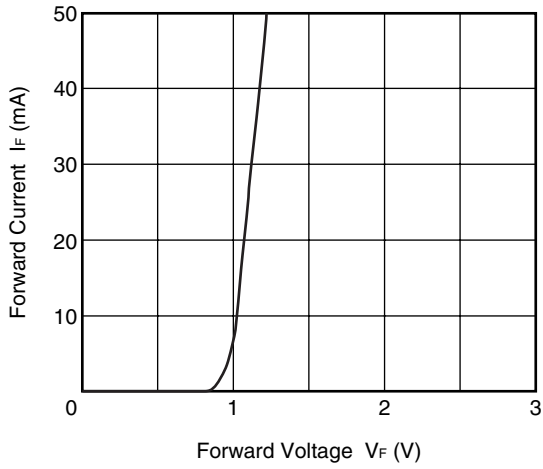

**OPTICAL OUTPUT POWER vs. MONITOR CURRENT**

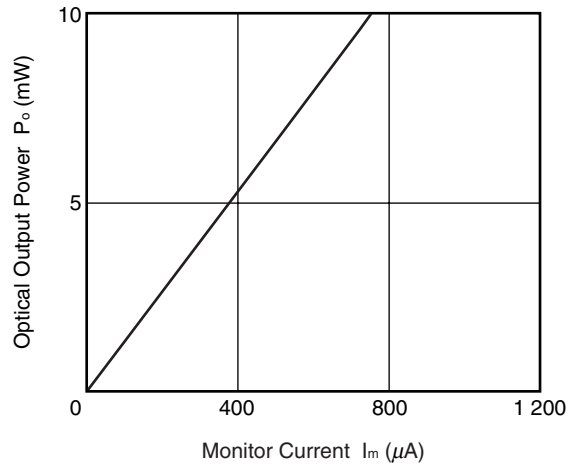

**SPECTRUM**

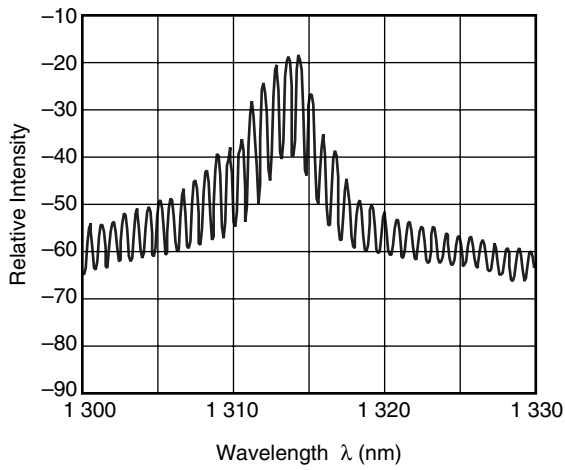

**TOLERANCE OF FIBER COUPLING DISTANCE (Z)**

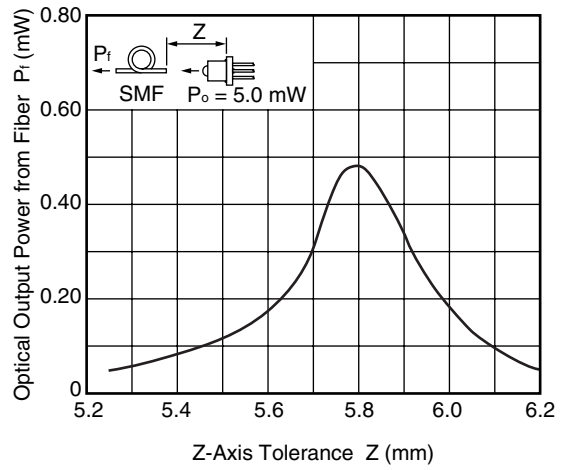

**Remark** The graphs indicate nominal characteristics.

**REFERENCE**

Document Name	Document No.
Opto-Electronics Devices Pamphlet <sup>*1</sup>	PX10160E

\*1 Published by the former NEC Compound Semiconductor Devices, Ltd.

- **The information in this document is current as of July, 2006. The information is subject to change without notice. For actual design-in, refer to the latest publications of NEC Electronics data sheets or data books, etc., for the most up-to-date specifications of NEC Electronics products. Not all products and/or types are available in every country. Please check with an NEC Electronics sales representative for availability and additional information.**
- No part of this document may be copied or reproduced in any form or by any means without the prior written consent of NEC Electronics. NEC Electronics assumes no responsibility for any errors that may appear in this document.
- NEC Electronics does not assume any liability for infringement of patents, copyrights or other intellectual property rights of third parties by or arising from the use of NEC Electronics products listed in this document or any other liability arising from the use of such products. No license, express, implied or otherwise, is granted under any patents, copyrights or other intellectual property rights of NEC Electronics or others.
- Descriptions of circuits, software and other related information in this document are provided for illustrative purposes in semiconductor product operation and application examples. The incorporation of these circuits, software and information in the design of a customer's equipment shall be done under the full responsibility of the customer. NEC Electronics assumes no responsibility for any losses incurred by customers or third parties arising from the use of these circuits, software and information.
- While NEC Electronics endeavors to enhance the quality, reliability and safety of NEC Electronics products, customers agree and acknowledge that the possibility of defects thereof cannot be eliminated entirely. To minimize risks of damage to property or injury (including death) to persons arising from defects in NEC Electronics products, customers must incorporate sufficient safety measures in their design, such as redundancy, fire-containment and anti-failure features.
- NEC Electronics products are classified into the following three quality grades: "Standard", "Special" and "Specific".

The "Specific" quality grade applies only to NEC Electronics products developed based on a customer-designated "quality assurance program" for a specific application. The recommended applications of an NEC Electronics product depend on its quality grade, as indicated below. Customers must check the quality grade of each NEC Electronics product before using it in a particular application.

"Standard": Computers, office equipment, communications equipment, test and measurement equipment, audio and visual equipment, home electronic appliances, machine tools, personal electronic equipment and industrial robots.

"Special": Transportation equipment (automobiles, trains, ships, etc.), traffic control systems, anti-disaster systems, anti-crime systems, safety equipment and medical equipment (not specifically designed for life support).

"Specific": Aircraft, aerospace equipment, submersible repeaters, nuclear reactor control systems, life support systems and medical equipment for life support, etc.

The quality grade of NEC Electronics products is "Standard" unless otherwise expressly specified in NEC Electronics data sheets or data books, etc. If customers wish to use NEC Electronics products in applications not intended by NEC Electronics, they must contact an NEC Electronics sales representative in advance to determine NEC Electronics' willingness to support a given application.

(Note)

(1) "NEC Electronics" as used in this statement means NEC Electronics Corporation and also includes its majority-owned subsidiaries.

(2) "NEC Electronics products" means any product developed or manufactured by or for NEC Electronics (as defined above).

**SAFETY INFORMATION ON THIS PRODUCT**

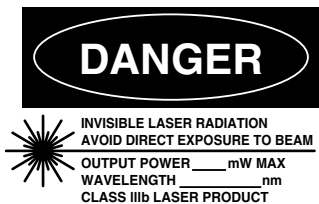

**SEMICONDUCTOR LASER**

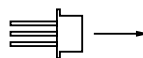

**AVOID EXPOSURE-Invisible**  
 Laser Radiation is emitted from  
 this aperture

<p><b>Warning</b> Laser Beam</p>	<p>A laser beam is emitted from this diode during operation. The laser beam, visible or invisible, directly or indirectly, may cause injury to the eye or loss of eyesight.</p> <ul style="list-style-type: none"> <li>• Do not look directly into the laser beam.</li> <li>• Avoid exposure to the laser beam, any reflected or collimated beam.</li> </ul>
<p><b>Caution</b> GaAs Products</p>	<p>This product uses gallium arsenide (GaAs). GaAs vapor and powder are hazardous to human health if inhaled or ingested, so please observe the following points.</p> <ul style="list-style-type: none"> <li>• Follow related laws and ordinances when disposing of the product. If there are no applicable laws and/or ordinances, dispose of the product as recommended below.                     <ol style="list-style-type: none"> <li>1. Commission a disposal company able to (with a license to) collect, transport and dispose of materials that contain arsenic and other such industrial waste materials.</li> <li>2. Exclude the product from general industrial waste and household garbage, and ensure that the product is controlled (as industrial waste subject to special control) up until final disposal.</li> </ol> </li> <li>• Do not burn, destroy, cut, crush, or chemically dissolve the product.</li> <li>• Do not lick the product or in any way allow it to enter the mouth.</li> </ul>

► For further information, please contact

**NEC Compound Semiconductor Devices Hong Kong Limited**

E-mail: [contact@ncsd-hk.necel.com](mailto:contact@ncsd-hk.necel.com)

Hong Kong Head Office TEL: +852-3107-7303 FAX: +852-3107-7309  
 Taipei Branch Office TEL: +886-2-8712-0478 FAX: +886-2-2545-3859  
 Korea Branch Office TEL: +82-2-558-2120 FAX: +82-2-558-5209

**NEC Electronics (Europe) GmbH** <http://www.eu.necel.com/>

TEL: +49-211-6503-0 FAX: +49-211-6503-1327

**California Eastern Laboratories, Inc.** <http://www.cel.com/>

TEL: +1-408-988-3500 FAX: +1-408-988-0279

**Compound Semiconductor Devices Division**

**NEC Electronics Corporation**

URL: <http://www.ncsd.necel.com/>