

HD74HC292

HD74HC294



● Programmable Frequency Divider/Digital Timer

This device divides the incoming clock frequency by a number (a power of 2) that is preset by the Programming inputs. It has two Clock inputs, either of which may be used as a clock inhibit. The device also has an active-low Reset, which initializes the internal flip-flop states. Test Point outputs (TP1, TP2, TP3) are provided with HD74HC292 to facilitate incoming inspections. Test Point output, is provided with HD74HC294 to facilitate incoming inspections.

■ FEATURES

- High Speed Operation: t_{pd} (Clock to Q)=16ns typ. ($C_L=50pF$)
- High Output Current: Fanout of 10 LSTTL Loads
- Wide Operating Voltage: $V_{CC}=2\sim 6V$
- Low Input Current: $1\mu A$ max.
- Low Quiescent Supply Current: I_{CC} (static)= $4\mu A$ max. ($T_a=25^\circ C$)

■ FUNCTION TABLE

Clear	Clock1	Clock2	Q Output Mode
L	x	x	Cleared to L
H		L	Count
H	L		Count
H	H	x	Inhibit
H	x	H	Inhibit

■ LOGIC DIAGRAM

● HD74HC292

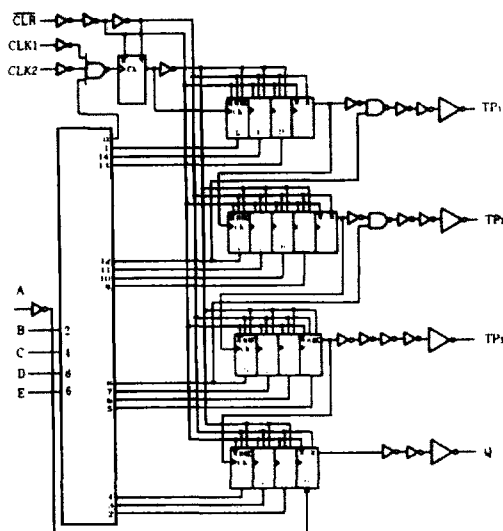

■ PIN ARRANGEMENT

● HD74HC292

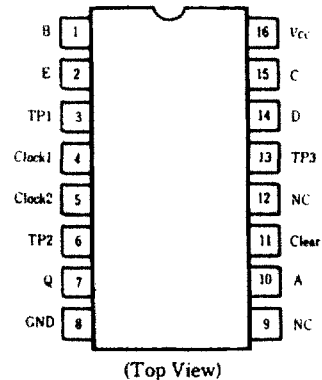

● HD74HC294

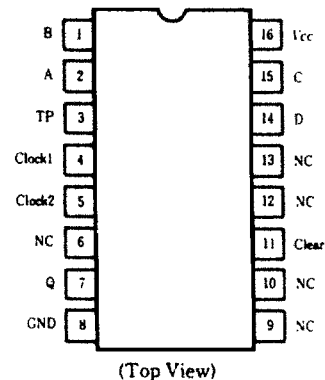

● HD74HC294

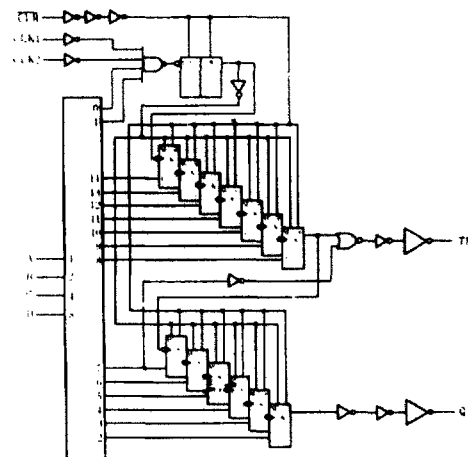

HD74HC292, HD74HC294

FUNCTION TABLE

HD74HC292

Programming Inputs					Frequency Division							
E	D	C	B	A	Q Out		TP1		TP2		TP3	
					Binary	Decimal	Binary	Decimal	Binary	Decimal	Binary	Decimal
L	L	L	L	L	Inhibit	Inhibit	Inhibit	Inhibit	Inhibit	Inhibit	Inhibit	Inhibit
L	L	L	L	H	Inhibit	Inhibit	Inhibit	Inhibit	Inhibit	Inhibit	Inhibit	Inhibit
L	L	L	H	L	2 ²	4	2 ⁹	512	2 ¹⁷	131,072	2 ²⁴	16,777,216
L	L	L	H	H	2 ³	8	2 ⁹	512	2 ¹⁷	131,072	2 ²⁴	16,777,216
L	L	H	L	L	2 ⁴	16	2 ⁹	512	2 ¹⁷	131,072	2 ²⁴	16,777,216
L	L	H	L	H	2 ⁵	32	2 ⁹	512	2 ¹⁷	131,072	2 ²⁴	16,777,216
L	L	H	H	L	2 ⁶	64	2 ⁹	512	2 ¹⁷	131,072	2 ²⁴	16,777,216
L	L	H	H	H	2 ⁷	128	2 ⁹	512	2 ¹⁷	131,072	2 ²⁴	16,777,216
L	H	L	L	L	2 ⁸	256	2 ⁹	512	2 ¹⁷	131,072	2 ²⁴	16,777,216
L	H	L	L	H	2 ⁹	512	2 ⁹	512	2 ¹⁷	131,072	2 ²	4
L	H	L	H	L	2 ¹⁰	1,024	2 ⁹	512	2 ¹⁷	131,072	2 ²	16
L	H	L	H	H	2 ¹¹	2,048	2 ⁹	512	2 ¹⁷	131,072	2 ²	16
L	H	H	L	L	2 ¹²	4,096	2 ⁹	512	2 ¹⁷	131,072	2 ²	64
L	H	H	L	H	2 ¹³	8,192	2 ⁹	512	2 ¹⁷	131,072	2 ²	64
L	H	H	H	L	2 ¹⁴	16,384	2 ⁹	512	Disabled LOW		2 ²	256
L	H	H	H	H	2 ¹⁵	32,768	2 ⁹	512	Disabled LOW		2 ²	256
H	L	L	L	L	2 ¹⁶	65,536	2 ⁹	512	2 ²	8	2 ¹⁰	1,024
H	L	L	L	H	2 ¹⁷	131,072	2 ⁹	512	2 ²	8	2 ¹⁰	1,024
H	L	L	H	L	2 ¹⁸	262,144	2 ⁹	512	2 ²	32	2 ¹²	4,096
H	L	L	H	H	2 ¹⁹	524,288	2 ⁹	512	2 ²	32	2 ¹²	4,096
H	L	H	L	L	2 ²⁰	1,048,576	2 ⁹	512	2 ⁷	128	2 ¹⁴	16,384
H	L	H	L	H	2 ²¹	2,097,152	2 ⁹	512	2 ⁷	128	2 ¹⁴	16,384
H	L	H	H	L	2 ²²	4,194,304	Disabled LOW		2 ⁹	512	2 ¹⁶	65,536
H	L	H	H	H	2 ²³	8,388,608	Disabled LOW		2 ⁹	512	2 ¹⁶	65,536
H	H	L	L	L	2 ²⁴	16,777,216	2 ²	8	2 ¹¹	2,048	2 ¹⁸	262,144
H	H	L	L	H	2 ²⁵	33,554,432	2 ²	8	2 ¹¹	2,048	2 ¹⁸	262,144
H	H	L	H	L	2 ²⁶	67,108,864	2 ²	32	2 ¹³	8,192	2 ²⁰	1,048,576
H	H	L	H	H	2 ²⁷	134,217,728	2 ²	32	2 ¹³	8,192	2 ²⁰	1,048,576
H	H	H	L	L	2 ²⁸	268,435,456	2 ⁷	128	2 ¹⁵	32,768	2 ²²	4,194,304
H	H	H	L	H	2 ²⁹	536,870,912	2 ⁷	128	2 ¹⁵	32,768	2 ²²	4,194,304
H	H	H	H	L	2 ³⁰	1,073,741,824	2 ⁹	512	2 ¹⁷	131,072	2 ²⁴	16,777,216
H	H	H	H	H	2 ³¹	2,147,483,648	2 ⁹	512	2 ¹⁷	131,072	2 ²⁴	16,777,216

HD74HC294

Programming Inputs				Frequency Division			
D	C	B	A	Q Output		TP Output	
				Binary	Decimal	Binary	Decimal
L	L	L	L	Inhibit	Inhibit	Inhibit	Inhibit
L	L	L	H	Inhibit	Inhibit	Inhibit	Inhibit
L	L	H	L	2 ²	4	2 ⁹	512
L	L	H	H	2 ³	8	2 ⁹	512
L	H	L	L	2 ⁴	16	2 ⁹	512
L	H	L	H	2 ⁵	32	2 ⁹	512
L	H	H	L	2 ⁶	64	2 ⁹	512
L	H	H	H	2 ⁷	128	Disabled LOW	
H	L	L	L	2 ⁸	256	2 ²	4
H	L	L	H	2 ⁹	512	2 ²	8
H	L	H	L	2 ¹⁰	1,024	2 ⁴	16
H	L	H	H	2 ¹¹	2,048	2 ⁵	32
H	H	L	L	2 ¹²	4,096	2 ⁶	64
H	H	L	H	2 ¹³	8,192	2 ⁷	128
H	H	H	L	2 ¹⁴	16,384	2 ⁹	256
H	H	H	H	2 ¹⁵	32,768	2 ⁹	512

■ DC CHARACTERISTICS

Item	Symbol	V _{CC} (V)	Test Conditions	T _a = 25°C			T _a = -40 ~ +85°C		Unit		
				min	typ	max	min	max			
Input Voltage	V _{IH}	2.0	V _{IH} - V _{IH} or V _{IL}	1.5	-	-	1.5	-	V		
		4.5		3.15	-	-	3.15	-			
		6.0		4.2	-	-	4.2	-			
	V _{IL}	2.0		-	-	0.5	-	0.5	V		
		4.5		-	-	1.35	-	1.35			
		6.0		-	-	1.8	-	1.8			
Output Voltage	V _{OH}	2.0	V _{IH} - V _{IH} or V _{IL}	I _{OH} = -20μA	1.9	2.0	-	1.9	-	V	
		4.5			4.4	4.5	-	4.4	-		
		6.0			5.9	6.0	-	5.9	-		
		I _{OH} = -4mA		4.18	-	-	4.13	-			
				I _{OH} = -5.2mA	5.68	-	-	5.63	-		
					-	-	-	-	-		
	V _{OL}	V _{IH} - V _{IH} or V _{IL}	I _{OL} = 20μA	2.0	-	0.0	0.1	-	0.1	V	
				4.5	-	0.0	0.1	-	0.1		
				6.0	-	0.0	0.1	-	0.1		
			I _{OL} = 4mA	0.26	-	-	0.26	-	0.33		
				I _{OL} = 5.2mA	0.26	-	-	0.26	-		0.33
					-	-	-	-	-		
Input Current	I _{is}	6.0	V _{IH} = V _{CC} or GND	-	-	±0.1	-	±1.0	μA		
Quiescent Supply Current	I _{CC}	6.0	V _{IH} = V _{CC} or GND, I _{is} = 0μA	-	-	4.0	-	40	μA		

■ AC CHARACTERISTICS (C_L = 50pF, Input t_r = t_f = 6ns)

Item	Symbol	V _{CC} (V)	Test Conditions	T _a = 25°C			T _a = -40 ~ +85°C		Unit
				min	typ	max	min	max	
Maximum Clock Frequency	f _{max}	2.0		-	-	5	-	4	MHz
		4.5		-	-	27	-	21	
		6.0		-	-	31	-	24	
Propagation Delay Time	t _{PLH} t _{PHL}	2.0	Clock to Output	-	-	690	-	750	ns
		4.5		-	16	120	-	150	
		6.0		-	-	160	-	125	
Removal Time	t _{rem}	2.0		100	-	-	125	-	ns
		4.5		20	-4	-	25	-	
		6.0		17	-	-	21	-	
Pulse Width	t _w	2.0		80	-	-	100	-	ns
		4.5		16	14	-	20	-	
		6.0		14	-	-	17	-	
Output Rise/Fall Time	t _{TLH} t _{THL}	2.0		-	-	75	-	95	ns
		4.5		-	5	15	-	19	
		6.0		-	-	13	-	16	
Input Capacitance	C _{is}	-		-	5	10	-	10	pF