

## STEPPER MOTOR DRIVER

### ■ GENERAL DESCRIPTION

**NJM37770** is a stepper motor driver, which consists of a LS-TTL compatible logic input stage, a current sensor, a monostable multivibrator and a high power H-bridge output stage. The **NJM37770** is a high power version and pincompatible with the **NJM37717** and also **NJM37770** is a high voltage version with **NJM3770A**. Two **NJM37770** and a small number of external components form a complete control and drive unit stepper motor systems.

### ■ PACKAGE OUTLINE

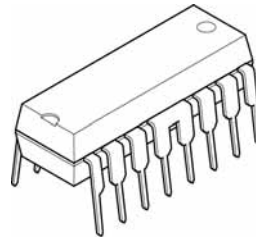

**NJM37770D3**  
(DIP16-D3)

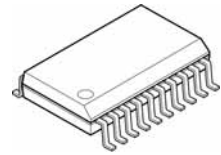

**NJM37770E2**  
(SOP20-E2)

### ■ FEATURES

- Half-step and full-step operation
- Switched mode bipolar constant current drive

- Wide range of current control                    5 to 1500mA
- Wide voltage range                                10 to 60 V

- Thermal overload protection
- Packages

DIP16 (Batwing) / SOP20-E2 JEDEC 300mil

### ■ BLOCK DIAGRAM

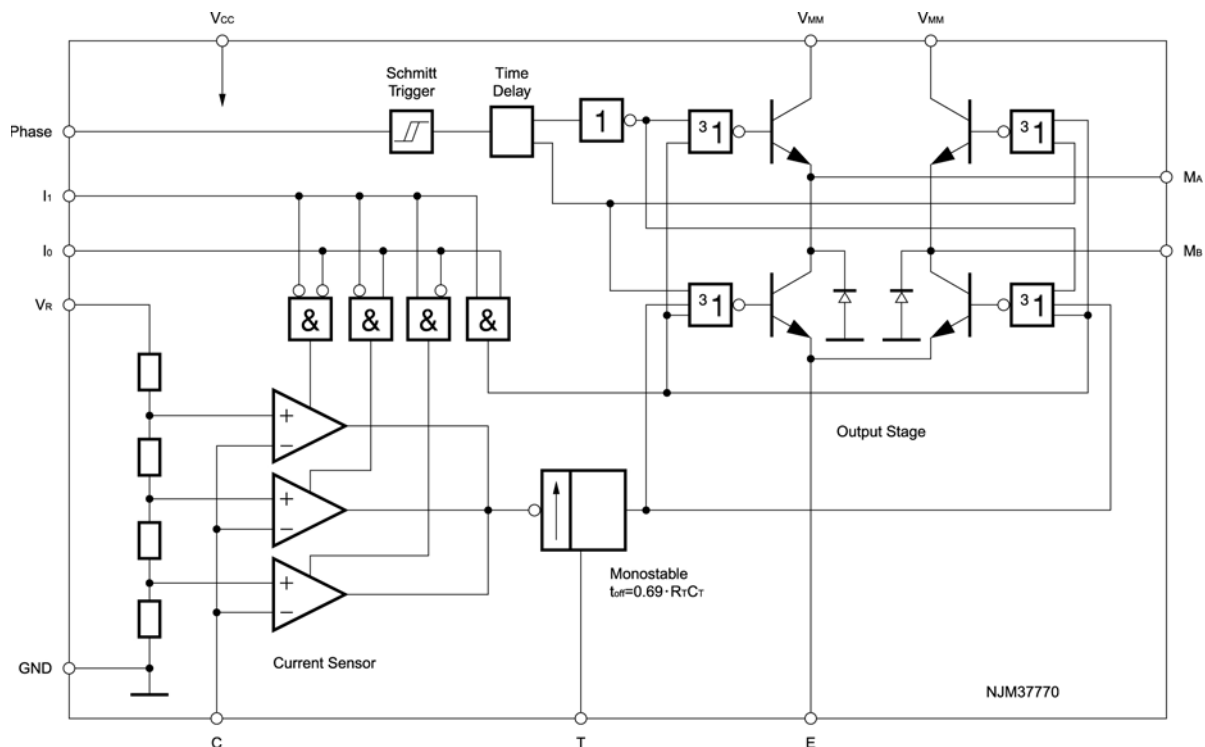

Figure 1. Block diagram

# NJM37770

## ■ PIN CONFIGURATION

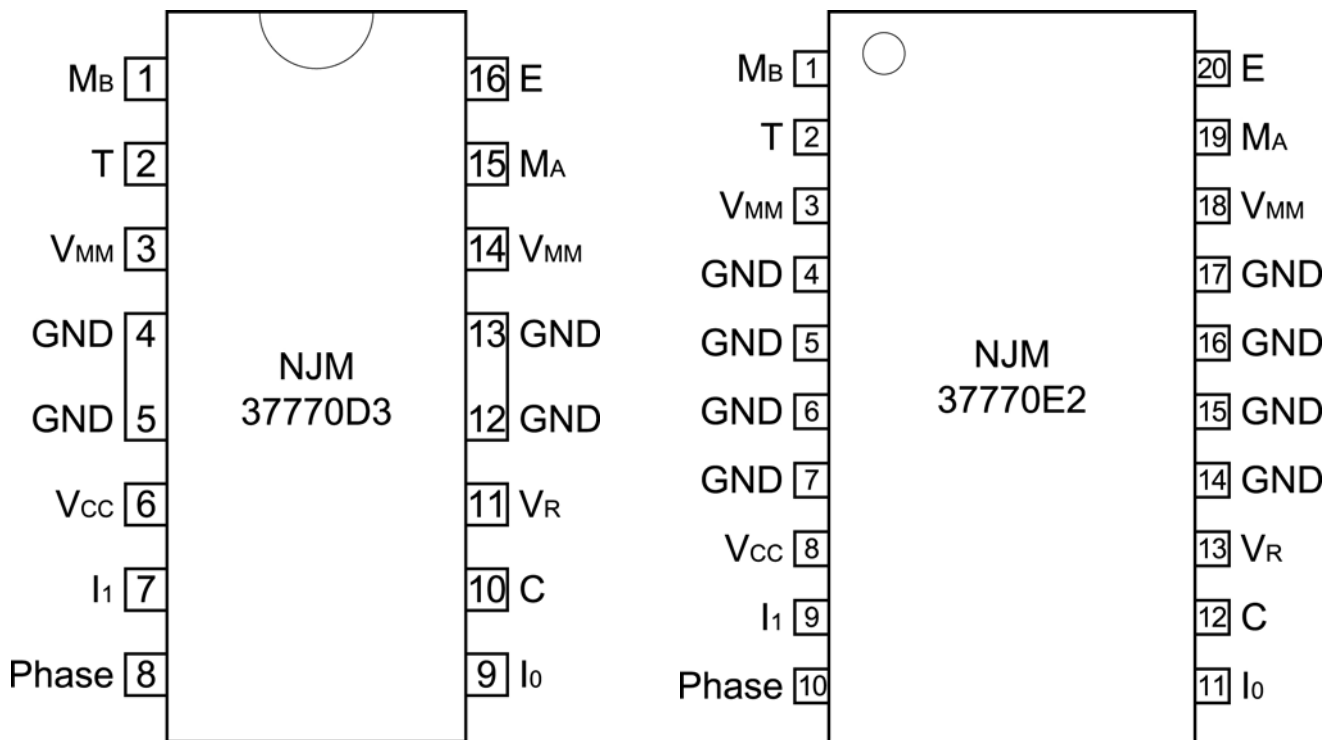

Figure 2. Pin configuration

## ■ PIN DESCRIPTION

DIP	SOP	Symbol	Description
1	1	M <sub>B</sub>	Motor output B, Motor current flows from M <sub>A</sub> to M <sub>B</sub> when Phase is high.
2	2	T	Clock oscillator. Timing pin connect a 56 kΩ resistor and a 820 pF in parallel between T and Ground.
3,14	3,18	V <sub>MM</sub>	Motor supply voltage, 10 to 40 V. Pin 3 and pin 14(SOP pin 18) should be wired to gether.
4,5,12,13	4-7,14-17	GND	Ground and negative supply. Note these pins are used for heatsinking. Make sure that all ground pins are soldered onto a suitable large copper ground plane for efficient heat sinking.
6	8	V <sub>CC</sub>	Logic voltage supply normally +5 V.
7	9	I <sub>1</sub>	Logic input. It controls, together with the I <sub>0</sub> input, the current level in the output stage. The controllable levels are fixed to 100, 60, 20, 0%.
8	10	Phase	Controls the direction of the motor current of M <sub>A</sub> and M <sub>B</sub> outputs. Motor current flows from M <sub>A</sub> to M <sub>B</sub> when the phase input is high.
9	11	I <sub>0</sub>	Logic input. It controls, together with the I <sub>1</sub> input, the current level in the output stage. The controllable levels are fixed to 100, 60, 20, 0%.
10	12	C	Comparator input. This input senses the instantaneous voltage across the sensing resistor, filtered through a RC Network.
11	13	V <sub>R</sub>	Reference voltage. Controls the threshold voltage of the comparator and hence the output current. Input resistance: typically 6.8 kΩ ±20%.
15	19	M <sub>A</sub>	Motor output A, Motor current flows from M <sub>A</sub> to M <sub>B</sub> when Phase is high.
16	20	E	Common emitter. Connect the Sense resistor between this pin and ground.

## FUNCTIONAL DESCRIPTION

The **NJM37770** is intended to drive a bipolar constant current through one winding of a 2-phase stepper motor. Current control is achieved through switched-mode regulation, see figure 3 and 4.

Three different current levels and zero current can be selected by the input logic.

The circuit contains the following functional blocks:

- Input logic
- Current sense
- Single-pulse generator
- Output stage

### Input logic

#### Phase input

The phase input determines the direction of the current in the motor winding. High input forces the current from terminal  $M_A$  to  $M_B$  and low input from terminal  $M_B$  to  $M_A$ . A Schmitt trigger provides noise immunity and a delay circuit eliminates the risk of cross conduction in the output stage during a phase shift.

Half- and full-step operation is possible.

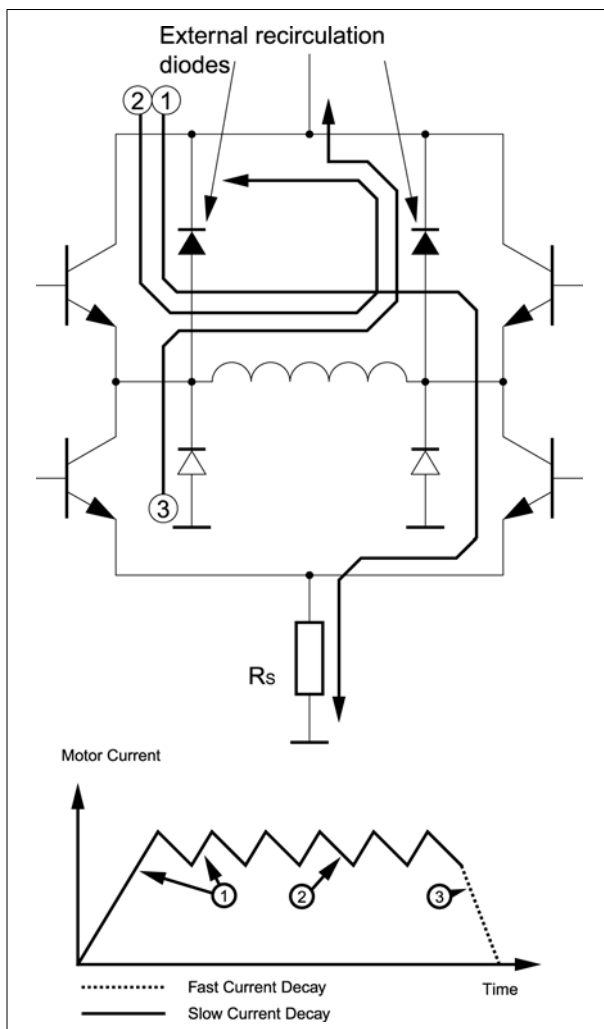

**Figure 3. Output stage with current paths for fast and slow current decay.**

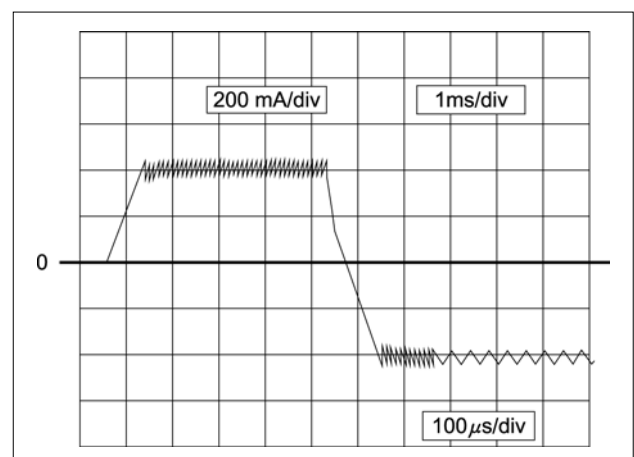

**Figure 4. Motor current ( $I_M$ ),**  
**Vertical : 200 mA/div,**  
**Horizontal: 1 ms/div,**  
**expanded part 100  $\mu$ s/div.**

## Current level selection.

The status of  $I_0$  and  $I_1$  inputs determines the current level in the motor winding. Three fixed current levels can be selected according to the table below.

Motor current		$I_0$	$I_1$
High level	100%	L	L
Medium level	60%	H	L
Low level	20%	L	H
Zero current	0%	H	H

The specific values of the different current levels are determined by the reference voltage  $V_R$  together with the value of the sensing resistor  $R_S$ .

The peak motor current can be calculated as follows:

$$i_m = (V_R \cdot 0.080) / R_S \text{ [A], at 100% level}$$

The motor current can also be continuously varied by modulating the voltage reference input.

## Current sensor

The current sensor contains a reference voltage divider and three comparators for measuring each of the selectable current levels. The motor current is sensed as a voltage drop across the current sensing resistor,  $R_S$ , and compared with one of the voltage references from the divider. When the two voltages are equal, the comparator triggers the single-pulse generator. Only one comparator at a time is activated by the input logic.

## Single-pulse generator

The pulse generator is a monostable multivibrator triggered on the positive edge of the comparator output. The multivibrator output is high during the pulse time,  $t_{off}$ , which is determined by the timing components  $R_T$  and  $C_T$ .

$$t_{off} = 0.69 \cdot R_T \cdot C_T$$

The single pulse switches off the power feed to the motor winding, causing the winding to decrease during  $t_{off}$ .

If a new trigger signal should occur during  $t_{off}$ , it is ignored.

## Output stage

The output stage contains four transistors and two diodes, connected in an H-bridge. Note that the upper recirculation diodes are connected to the circuit externally. The two sinking transistors are used to switch the power supplied to the motor winding, thus driving a constant current through the winding. See figures 3 and 4.

## Overload protection

The circuit is equipped with a thermal shut-down function, which will limit the junction temperature. The output current will be reduced if the maximum permissible junction temperature is exceeded. It should be noted, however, that it is not short circuit protected.

## Operation

When a voltage  $V_{MM}$  is applied across the motor winding, the current rise follows the equation:

$$i_m = (V_{MM} / R) \cdot (1 - e^{-(R \cdot t) / L})$$

$R$  = Winding resistance

$L$  = Winding inductance

$t$  = time

(see figure 3, arrow 1)

The motor current appears across the external sensing resistor,  $R_S$ , as an analog voltage. This voltage is fed through a low-pass filter,  $R_{CC}$ , to the voltage comparator input (DIP pin 10, SOP pin 12). At the moment the sensed voltage rises above the comparator threshold voltage, the monostable is triggered and its output turns off the conducting sink transistor. The polarity across the motor winding reverses and the current is forced to circulate through the appropriate upper protection diode back through the source transistor (see figure 3, arrow 2).

After the monostable has timed out, the current has decayed and the analog voltage across the sensing resistor is below the comparator threshold level. The sinking transistor then turns on and the motor current starts to increase again. The cycle is repeated until the current is turned off via the logic inputs. When both  $I_1$  and  $I_0$  are high, all four transistors in the output H-bridge are turned off, which means that inductive current recirculates through two opposite free-wheeling diodes (see figure 3, arrow 3). This method of turning off the current results in a faster current decay than if only one transistor was turned off and will therefore improve speed performance in half-stepping mode.

## ■ ABSOLUTE MAXIMUM RATINGS

Parameter	Pin no. [DIP package]	Symbol	Min	Max	Unit
<b>Voltage</b>					
Logic supply	6	$V_{CC}$	0	7	V
Motor supply	3, 14	$V_{MM}$	0	60	V
Logic inputs	7,8,9	$V_I$	-0.3	6	V
Comparator input	10	$V_C$	-0.3	$V_{CC}$	V
Reference input	11	$V_R$	-0.3	15	V
<b>Current</b>					
Motor output current	1, 15	$I_M$	-1500	+1500	mA
Logic inputs	7,8,9	$I_I$	-10	-	mA
Analog inputs	10,11	$I_A$	-10	-	mA
<b>Temperature</b>					
Operating junction temperature		$T_j$	-40	+150	°C
Storage temperature		$T_s$	-55	+150	°C

## ■ RECOMMENDED OPERATING CONDITIONS

( $T_a=25^\circ\text{C}$ )

Parameter	Symbol	Min	Typ	Max	Unit
Logic supply voltage	$V_{CC}$	4.75	5	5.25	V
Motor supply voltage	$V_{MM}$	10	-	55	V
Motor output current	$I_M$	-1300	-	+1300	mA
Junction temperature	$T_j$	-20	-	+125	°C
Rise time logic inputs	$t_r$	-	-	2	$\mu\text{s}$
Fall time logic inputs	$t_f$	-	-	2	$\mu\text{s}$

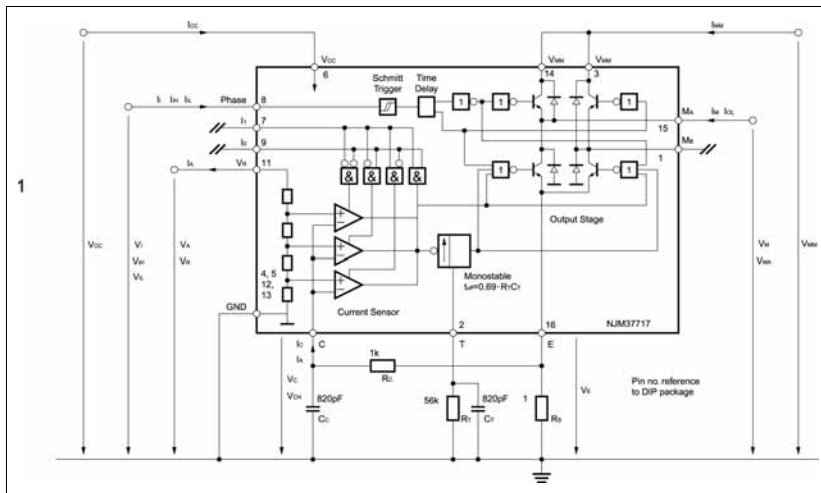

Figure 5. Definition of symbols

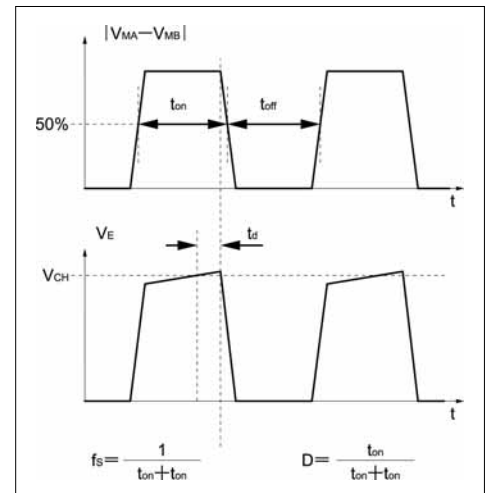

Figure 6. Definition of terms

# NJM37770

## ■ ELECTRICAL CHARACTERISTICS

Electrical characteristics over recommended operating conditions, unless otherwise specified.  $T_a=25^{\circ}\text{C}$   $C_T=820\text{pF}$ ,  $R_T=56\text{k}\Omega$

Parameter	Symbol	Conditions	Min	Typ	Max	Unit
<b>General</b>						
Supply current	$I_{CC}$	$V_{MM}=20$ to $55\text{V}$ , $I_0=I_1=\text{HIGH}$ .	-	30	40	mA
		$V_{MM}=20$ to $55\text{V}$ , $I_0=I_1=\text{LOW}$ , $f_s=23\text{kHz}$	-	48	65	mA
Total power dissipation	$P_D$	$f_s=28\text{kHz}$ , $I_M=1.0\text{A}$ , $V_{MM}=36\text{V}$ Note 2, 4.	-	1.9	2.3	W
		$f_s=24\text{kHz}$ , $I_M=1.0\text{A}$ , $V_{MM}=12\text{V}$ Note2, 4.	-	1.7	2.1	W
		$f_s=28\text{kHz}$ , $I_M=1.3\text{A}$ , $V_{MM}=36\text{V}$ Note3, 4.	-	2.7	3.2	W
		$f_s=28\text{kHz}$ , $I_M=1.5\text{A}$ , $V_{MM}=36\text{V}$ Note3, 4.	-	3.5	-	W
		$f_s=28\text{kHz}$ , $I_M=1.0\text{A}$ , $V_{MM}=48\text{V}$ Note3, 4.	-	3.5	-	W
Turn-off delay	$t_d$	$dV/dt \geq 50\text{mV}/\mu\text{s}$ . $V_{MM}=48\text{V}$ , $R_L=200\Omega$	-	2.0	2.3	$\mu\text{s}$
Thermal shutdown junction temperature			-	165	-	$^{\circ}\text{C}$
<b>Logic Inputs</b>						
Logic HIGH input voltage	$V_{IH}$		2.0	-	-	V
Logic LOW input voltage	$V_{IL}$		-	-	0.8	V
Logic HIGH input current	$I_{IH}$	$V_I=2.4\text{V}$	-	-	20	$\mu\text{A}$
Logic LOW input current	$I_{IL}$	$V_I=0.4\text{V}$	-0.4	-	-	mA
<b>Analog Inputs</b>						
Comparator threshold voltage	$V_{CH}$	$V_R=5.0\text{V}$ , $I_0=I_1=\text{LOW}$	400	415	430	mV
Comparator threshold voltage	$V_{CM}$	$V_R=5.0\text{V}$ , $I_0=\text{HIGH}$ , $I_1=\text{LOW}$	240	250	265	mV
Comparator threshold voltage	$V_{CL}$	$V_R=5.0\text{V}$ , $I_0=\text{LOW}$ , $I_1=\text{HIGH}$	70	80	90	mV
Input current	$I_C$		-20	-	-	$\mu\text{A}$
<b>Motor Outputs</b>						
Lower transistor saturation voltage		$I_M=1.0\text{A}$	-	0.5	0.8	V
		$I_M=1.3\text{A}$	-	0.8	1.3	V
Lower diode forward voltage drop		$I_M=1.0\text{A}$	-	1.3	1.6	V
		$I_M=1.3\text{A}$	-	1.5	1.8	V
Upper transistor saturation voltage		$I_M=1.0\text{A}$	-	1.1	1.3	V
		$I_M=1.3\text{A}$	-	1.3	1.6	V
Output leakage current		$I_0=I_1=\text{HIGH}$	-	-	100	$\mu\text{A}$
<b>Monostable</b>						
Cut off time	$t_{off}$	$V_{MM}=10\text{V}$ , $t_{on} \geq 5\mu\text{s}$	27	31	35	$\mu\text{s}$

## ■ THERMAL CHARACTERISTICS

Parameter	Symbol	Conditions	Min	Typ	Max	Unit
Thermal resistance	$R_{thJ-GND}$	DIP package.	-	11	-	$^{\circ}\text{C}/\text{W}$
	$R_{thJ-A}$	DIP package. Note 2.	-	40	-	$^{\circ}\text{C}/\text{W}$
	$R_{thJ-GND}$	SOP package	-	11	-	$^{\circ}\text{C}/\text{W}$
	$R_{thJ-A}$	SOP package	-	40	-	$^{\circ}\text{C}/\text{W}$

### Notes

1. All voltages are with respect to ground. Currents are positive into, negative out of specified terminal
2. All ground pins soldered onto a  $20\text{ cm}^2$  PCB copper area with free air convection  $T_a=+25^{\circ}\text{C}$
3. DIP package with external heatsink (Staver V7) and minimal copper area. Typical  $R_{thJ-A}=27.5^{\circ}\text{C}/\text{W}$ .  $T_a=+25^{\circ}\text{C}$
4. Not covered by final test program

## ■ APPLICATIONS INFORMATION

### Motor selection

Some stepper motors are not designed for continuous operation at maximum current. As the circuit drives a constant current through the motor, its temperature can increase, both at low- and high-speed operation.

Some stepper motors have such high core losses that they are not suited for switched-mode operation.

### Interference

As the circuit operates with switched-mode current regulation, interference-generation problems can arise in some applications. A good measure is then to decouple the circuit with a 0.1  $\mu\text{F}$  ceramic capacitor, located near the package across the power line  $V_{\text{MM}}$  and ground.

Also make sure that the  $V_{\text{Ref}}$  input is sufficiently decoupled. An electrolytic capacitor should be used in the +5V rail, close to the circuit.

The ground leads between  $R_S$ ,  $C_C$  and circuit GND should be kept as short as possible. This applies also to the leads connecting  $R_S$  and  $R_C$  to pin 16 and pin 10 respectively.

In order to minimize electromagnetic interference, it is recommended to route  $M_A$  and  $M_B$  leads in parallel on the printed circuit board directly to the terminal connector. The motor wires should be twisted in pairs, each phase separately, when installing the motor system.

### Unused inputs

Unused inputs should be connected to proper voltage levels in order to obtain the highest possible noise immunity.

### Ramping

A stepper motor is a synchronous motor and does not change its speed due to load variations. This means that the torque of the motor must be large enough to match the combined inertia of the motor and load for all operation modes. At speed changes, the required torque increases by the square, and the required power by the cube of the speed change. Ramping, i.e., controlled acceleration or deceleration must then be considered to avoid motor pullout.

### $V_{\text{CC}}$ , $V_{\text{MM}}$

The supply voltages,  $V_{\text{CC}}$  and  $V_{\text{MM}}$ , can be turned on or off in any order. Normal  $dv/dt$  values are assumed.

Before a driver circuit board is removed from its system, all supply voltages must be turned off to avoid destructive transients being generated by the motor.

### Switching frequency

The motor inductance, together with the pulse time,  $t_{\text{off}}$ , determines the switching frequency of the current regulator. The choice of motor may then require other values on the  $R_T$ ,  $C_T$  components than those recommended in figure 3, to obtain a switching frequency above the audible range. Switching frequencies above 40 kHz are not recommended because the current regulation can be affected.

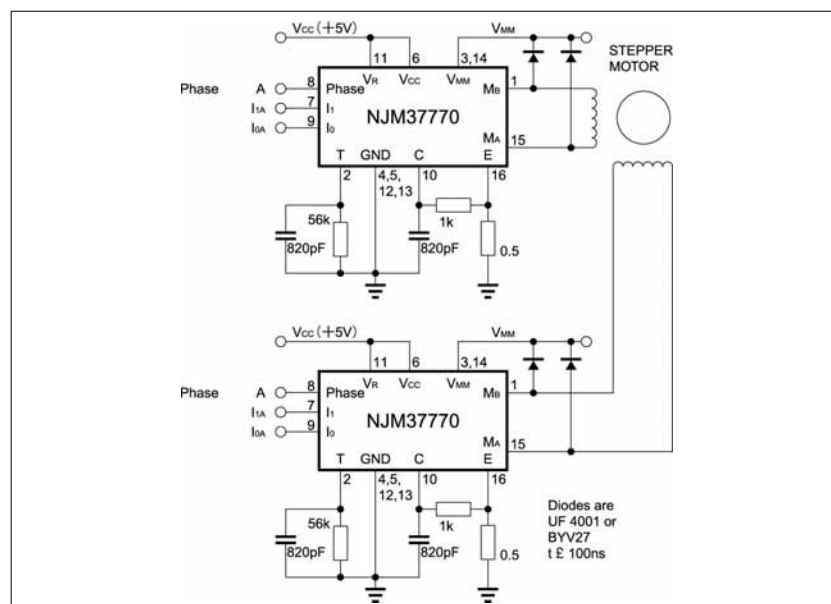

Figure 7. Typical stepper motor driver application with NJM37770

# NJM37770

## Analog control

As the current levels can be continuously controlled by modulating the  $V_R$  input, limited microstepping can be achieved.

## Sensor resistor

The  $R_S$  resistor should be of a noninductive type power resistor. A 0.5 ohm resistor, tolerance  $\leq 1\%$ , is a good choice for 800 mA max motor current at  $V_R = 5V$ .

The peak motor current,  $i_m$ , can be calculated by using the formula:

$$i_m = (V_R \cdot 0.080) / R_S \text{ [A]}, \text{ at 100\% level}$$

## External recirculation diodes

Recirculation diodes must be connected across each motor terminal and the supply voltage,  $V_{MM}$ . The anodes shall be connected to the motor terminals and the cathodes to the  $V_{MM}$  voltage. Ultra-fast recovery diodes should be used for maximum performance and reliability.

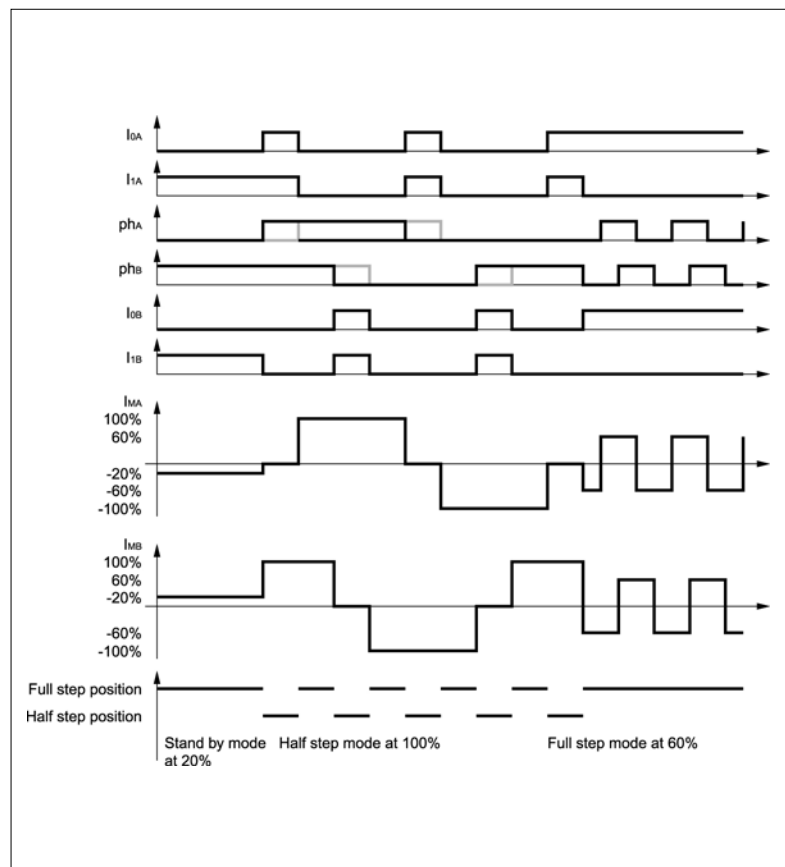
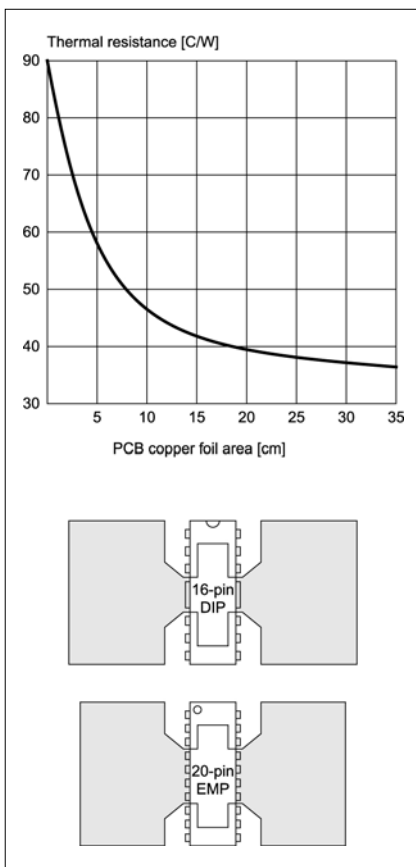

Figure 8. Copper foil used as a heatsink      Figure 9. Principal operating sequence.

## Heatsinking

The junction temperature of the chip highly effects the lifetime of the circuit. In high-current applications, the heatsinking must be carefully considered.

The  $R_{th(j-a)}$  of the **NJM37770** can be reduced by soldering the ground pins to a suitable copper ground plane on the printed circuit board (see figure 8) or by applying an external heatsink type V7 or V8, see figure 10.

The diagram in figure 15 shows the maximum permissible power dissipation versus the ambient temperature in °C, for heatsinks of the type V7, V8, or a 20 cm<sup>2</sup> copper area respectively. Any external heatsink or printed circuit board copper must be connected to electrical ground.

For motor currents higher than approx 600 mA, some form of heatsinking is recommended to assure optimal reliability.

The diagrams in figures 14 and 15 can be used to determine the required heatsinking of the circuit. In some systems, forced-air cooling may be available to reduce the temperature rise of the circuit.

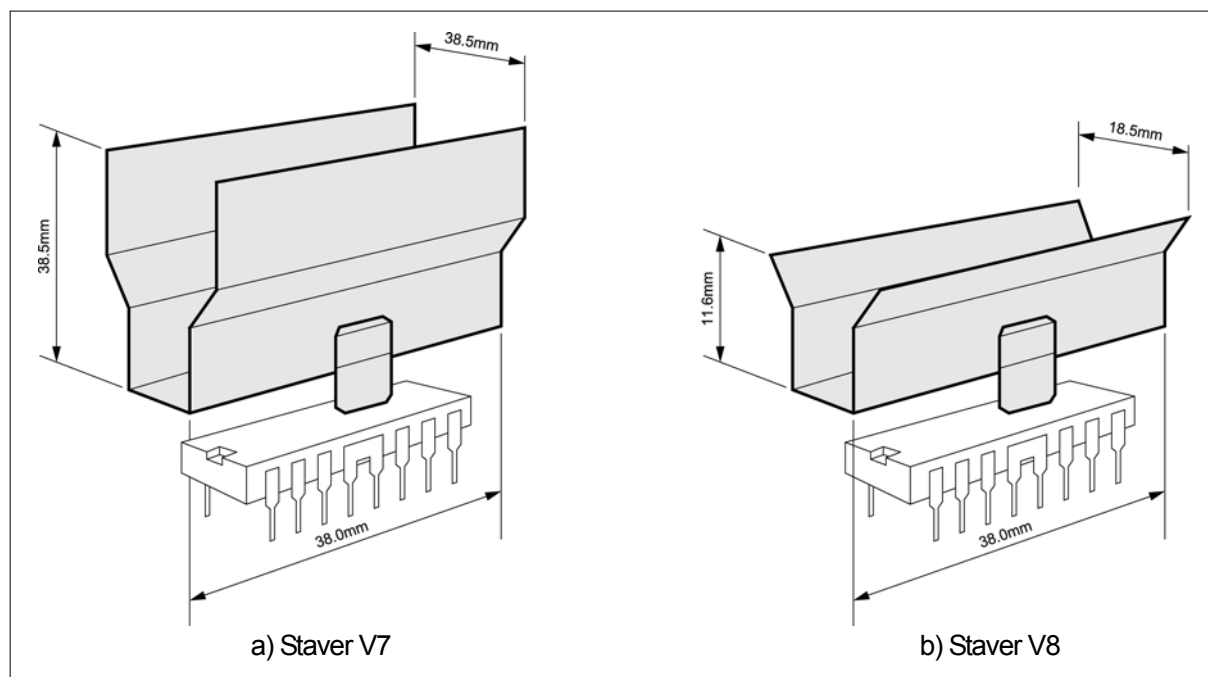

Figure 10. Heatsinks, Staver, type V7 and V8 by Columbia-Staver UK

## ■ TYPICAL CHARACTERISTICS

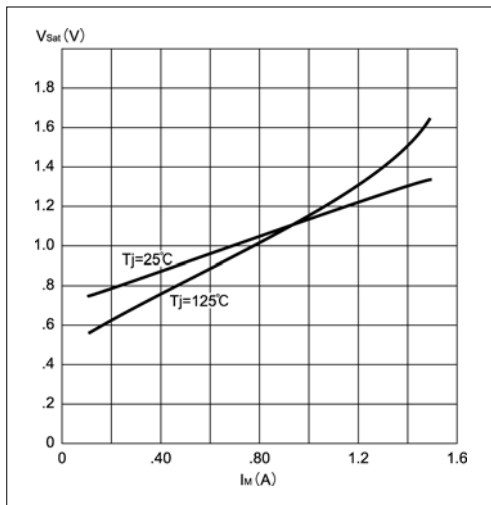

Figure 11. Typical source saturation vs. output current

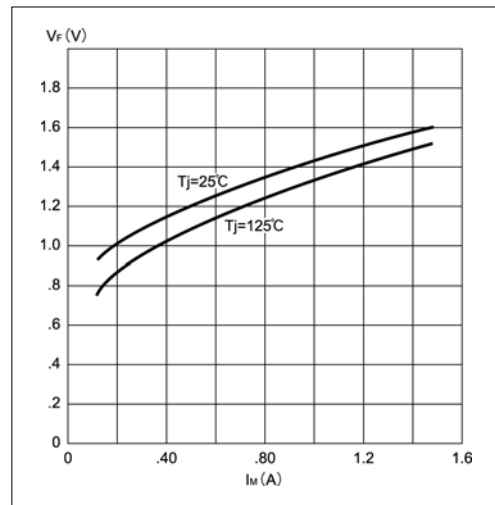

Figure 12. Typical lower diode voltage drop vs. recirculating current

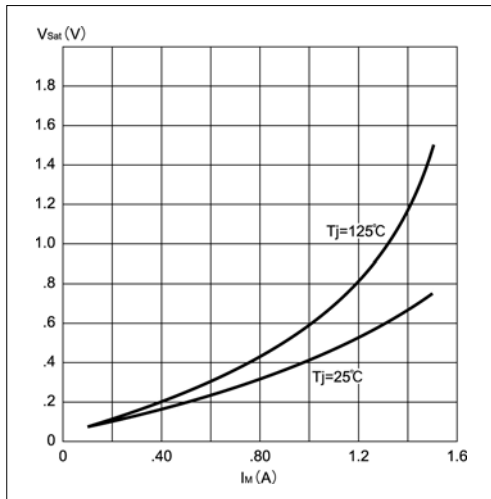

Figure 13. Typical sink saturation vs. output current

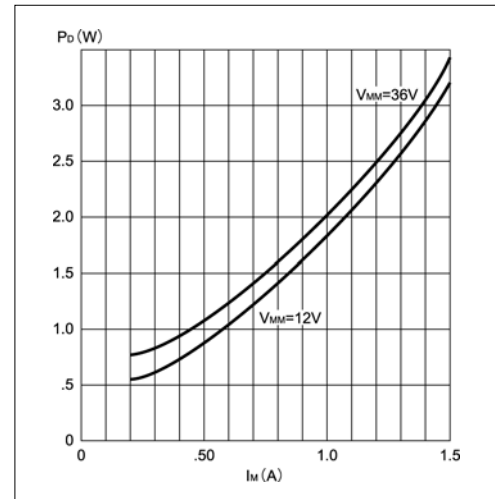

Figure 14. Typical power dissipation vs. motor current

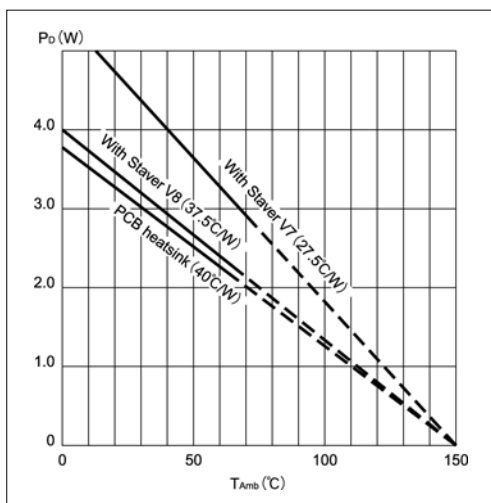

Figure 15. Allowable power dissipation vs. ambient temperature

[CAUTION]  
The specifications on this databook are only given for information, without any guarantee as regards either mistakes or omissions. The application circuits in this databook are described only to show representative usages of the product and not intended for the guarantee or permission of any right including the industrial rights.