

16-BIT MONOLITHIC TRACKING RESOLVER (LVDT)-TO-DIGITAL CONVERTER SERIES

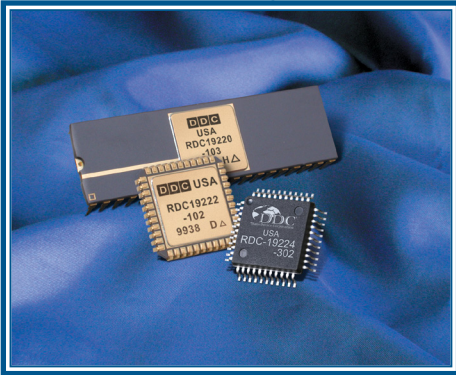

Model RDC-19220/2/4 RDC-19220/2S Series



FEATURES

- Accuracy to 2.3 Arc Minutes
- Internal Synthesized Reference Option (S Version)
 - Up to 45 Degree Phase Shift Correction
- +5 Volt Only Option
- Programmable:
 - Resolution 10, 12, 14 or 16 bit
 - Bandwidth
 - Tracking
- Standard MIL-PRF Selections Available
- -55° to +125° C Operation Temperature Option
- Small Size: Available in DDIP, J-LEAD, and MQFP Packages

DESCRIPTION

The RDC-19220/2/4, RDC-19220/2S Series are 16 bit monolithic tracking resolver to digital converters. These converter selections offer low cost off-the-shelf solutions for today's motion feedback applications. Mil-PRF-38534 processing options are also available. This single chip converter features programmable resolution of 10, 12, 14 or 16 bits with accuracies to 2.3 min. This converter can be configured for operation with a single +5VDC power supply. Programmable bandwidth and a velocity output used to replace tachometers can be scaled to your application needs. The velocity scale factor / tracking rate is programmed with a single resistor. The optional internal synthesized reference feature will eliminate errors due to quadrature voltage and ensure operation with a rotor-to-stator phase shift of up to 45 degrees.

APPLICATIONS

These converters offer versatile performance for use in motion control systems. Standard selections for MIL-PRF processing reduce lead time costs and no NRE or lot charges are necessary. Typical applications include motor control, machine tool control, robotics, flight surface control plus many more.

BENEFIT

Reduce in-house risk solutions and resources with faster time to market using these off the shelf solutions.

Make Sure the next Card you purchase has...



RDC-19220/2/4 and RDC-19220/2S Mechanical Outline

Figure 1

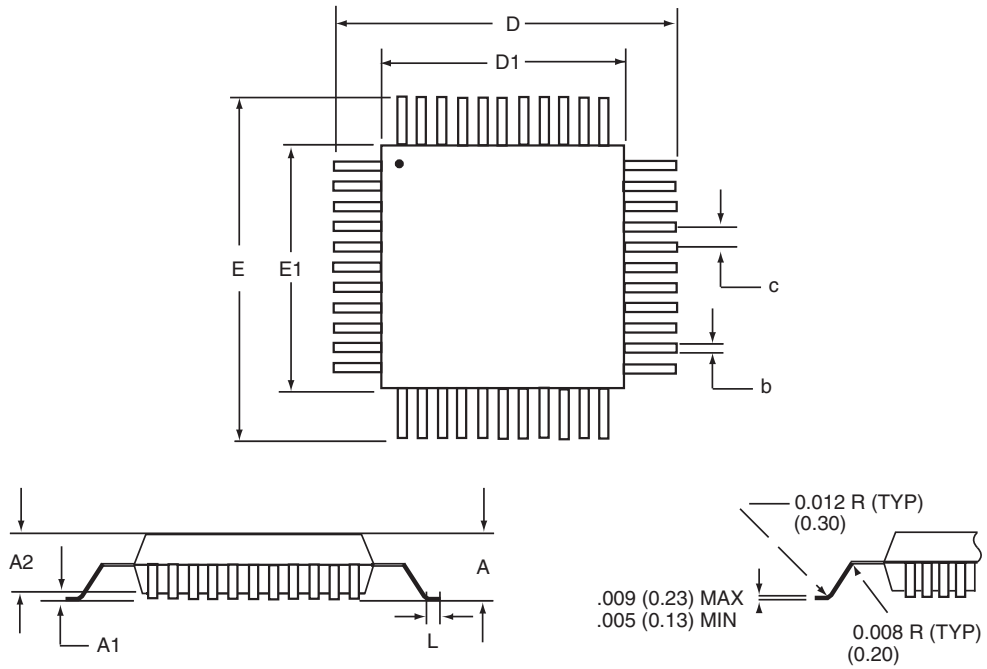
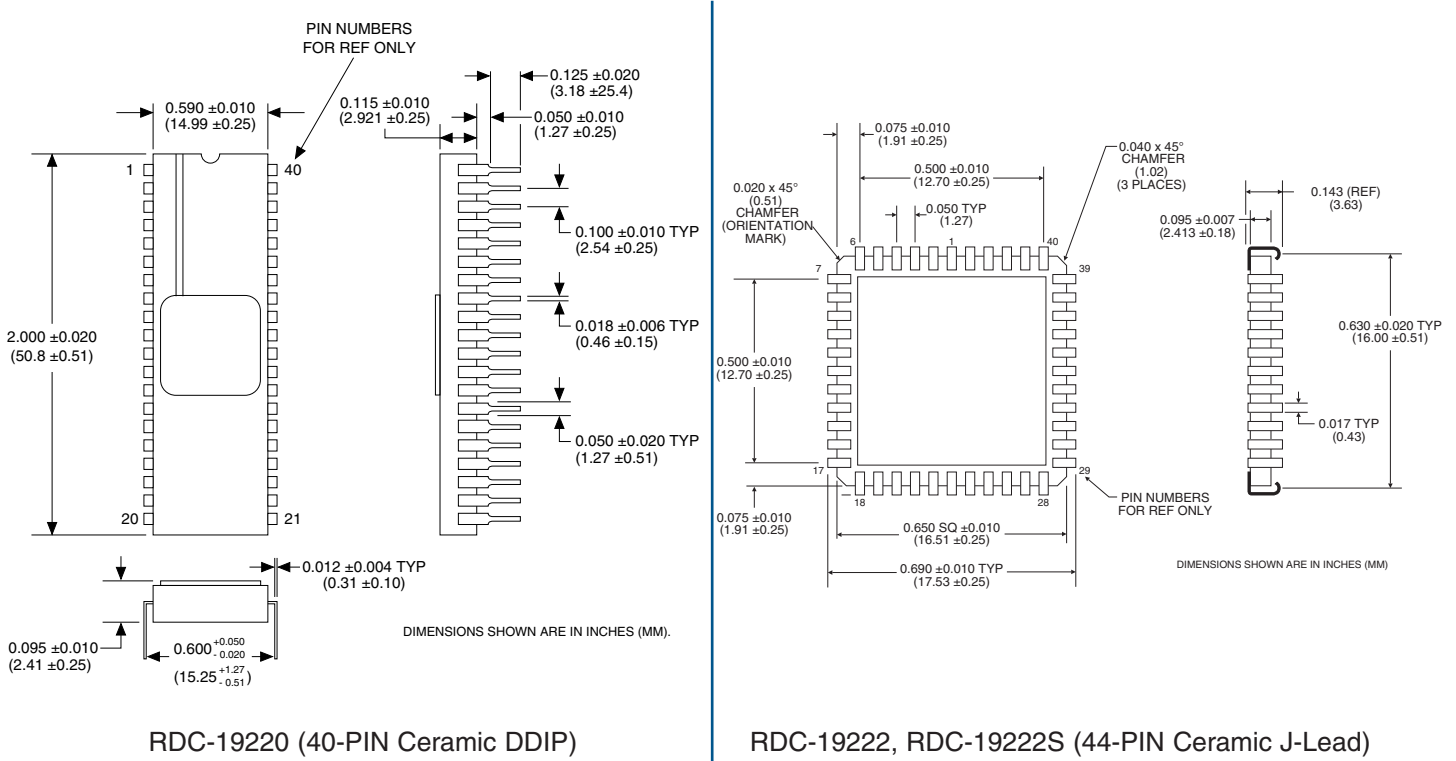

	A	A1	A2	D	D1	E	E1	L	c	b	
INCHES	.098 MAX	0.010 MIN	0.019 MAX	.078 + .004 - .002	.520 ± .010	.394 ± .004	.520 ± .010	.394 ± .004	.035 + .006 - .004	.0315 BSC	.0138 + .0020
MM	2.50 MAX	.25 MIN	.50 MAX	2.00 + .10 - .05	13.20 ± .25	10.00 ± .10	13.20 ± .25	10.00 ± .10	.88 + .15 - .10	.80 BSC	.35 + .05

RDC-19224 (44-Pin Plastic MQFP)

RDC-19220/2S SPECIFICATIONS

PARAMETER	UNIT	VALUE		
Frequency Range	Hz	47-1k (note 2)	1k-4k	4k-10k
Accuracy -XX2	Min	4+1 LSB	4+1 LSB	5+1 LSB
-XX3 (note 1)	Min	2+1 LSB	2+1 LSB	3+1 LSB
Reliability	LSB	±1	±1	±2
Differential Linearity	LSB	±1	±1	±2
Reference		(+Ref, -Ref)		
Type		Differential		
Voltage: differential	V	± 10 max		
Single ended	V	± 5 max		
Overload	V	± 25 continuous 100 transient		
Frequency	Hz	47 to 10,000		
Input Impedance	Ohm	10M min //20 pF		
±Sig/Ref Phase Shift	deg	45 max from 400Hz to 10kHz (note 3)		
Signal Input		(+S, -S, SIN, +C, -C, COS)		
Type		Resolver, differential, groundbase		
Voltage: operating	Vrms	2 ± 15%		
Overload	V	±25 continuous		
Input Impedance	Ohm	10M min//10pF		
Power Supplies (note 4)				
Nominal Voltage	V	+5	-5	
Voltage Range	%	±5	±5	
Max Volt w/o Damage	V	+7	-7	
Current	mA	14 typ, 22 max (each)		

RDC-19220/2/4 SPECIFICATIONS

PARAMETER	UNIT	VALUE	
Accuracy -XX2	Min	4+1 LSB	
-XX3 (note 1)	Min	2+1 LSB	
Reliability	LSB	±1	
Differential Linearity	LSB	±1	
Reference		(+Ref, -Ref)	
Type		Differential	
Voltage: differential	V	± 10 max	
Single ended	V	± 5 max	
Overload	V	± 25 continuous 100 transient	
Frequency	Hz	DC to 40kHz	
Input Impedance	Ohm	10M min //20 pF	
±Sig/Ref Phase Shift	deg	6 max	
Signal Input		(+S, -S, SIN, +C, -C, COS)	
Type		Resolver, differential, groundbase	
Voltage: operating	Vrms	2 ± 15%	
Overload	V	±25 continuous	
Input Impedance	Ohm	10M min//10pF	
Power Supplies (note 4)			
Nominal Voltage	V	+5	-5
Voltage Range	%	±5	±5
Max Volt w/o Damage	V	+7	-7
Current	mA	14 typ, 22 max (each)	

Notes:

1. Accuracy calculation for LVDT mode is described in the LVDT Accuracy section of the datasheet.
2. If the frequency is between 47Hz and 1kHz, then there may be 1 LSB of jitter at quadrant boundaries.
3. The maximum phase shift tolerance will degrade linearly from 45 degrees at 400 Hz to 30 degrees at 60 Hz.
4. See full datasheet for +5V only option details.

RDC-19220/2/4 and RDC-19220/2S Block Diagram

Figure 2

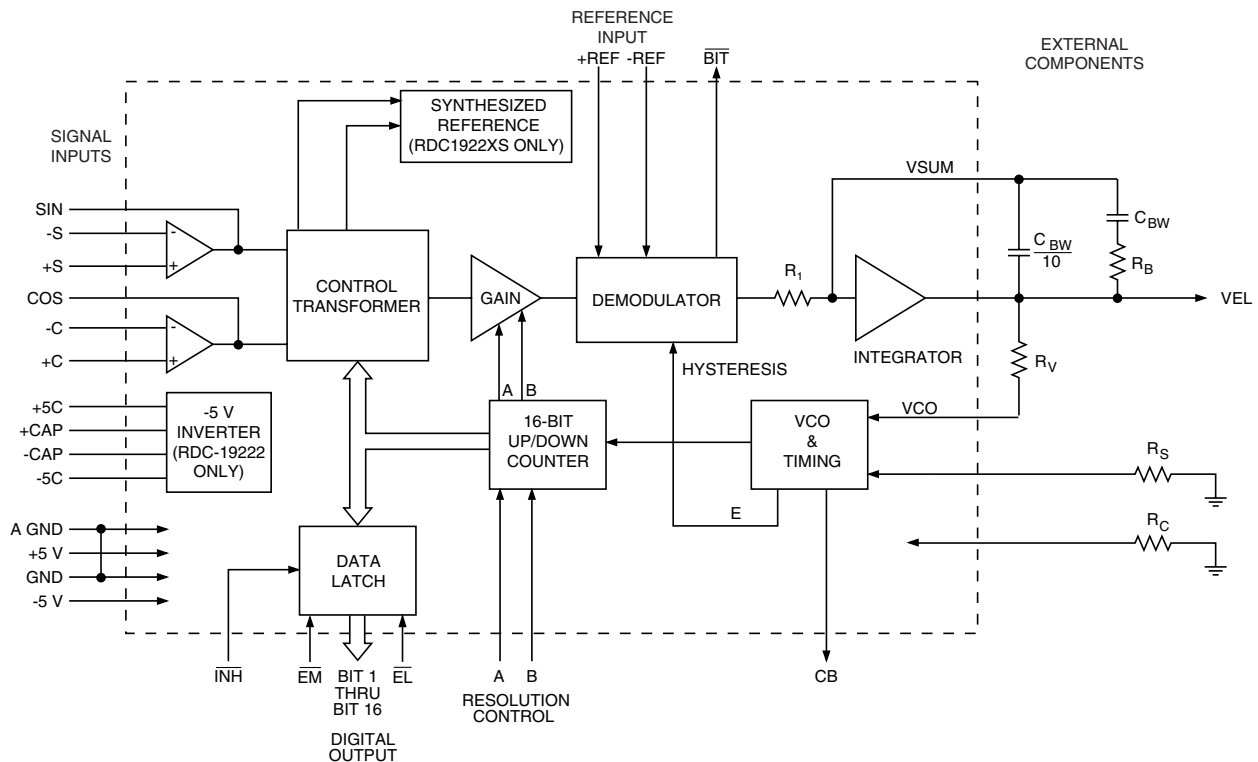

Ordering Information

RDC-19224 X-X X X X (Plastic Package: 44-pin MQFP)

- Supplemental Process Requirements:
T = Tape and Reel (not recommended)
Blank = None of the above
- Accuracy:
2 = 4 minutes + 1 LSB
3 = 2 minutes + 1 LSB
- Process Requirements:
0 = No Burn-In
- Temperature Grade/Data Requirements:
2 = -40°C to +85°C
3 = 0°C to +70°C
A = -40°C to +125°C
- Package Options:
Blank = Standard (note 2a, 2b)
G = Lead Free (RoHS Complaint) (note1)
- Package:
4 = MQFP 44 Pin

RDC-1922XX-X X X X

RDC-1922XS-X X X X (Ceramic Package)

- Supplemental Process Requirements:
T = Tape and Reel (not recommended)
S = Pre-Cap Source Inspection
L = 100% Pull Test
Q = Pre-Cap Source and 100% Pull Test
K = One Lot Date Code
W = One Lot Date Code and Pre-Cap Source Inspection
Y = One Lot Date Code and 100% Pull Test
Z = One Lot Date Code, Pre-Cap Source Inspection and 100% Pull Test
Blank = None of the above
- Accuracy:
2 = 4 minutes + 1 LSB
3 = 2 minutes + 1 LSB
- Process Requirements:
0 = No Burn-In
1 = MIL-PRF-38534 Compliant
2 = Standard DDC Processing, with Burn-In
3 = MIL-PRF-38534 Compliant, with PIND testing
4 = MIL-PRF-38534 Compliant, with Solder Dip
5 = MIL-PRF-38534 Compliant, with PIND testing, and Solder Dip
6 = Standard DDC Processing, with PIND testing, and Burn-In
7 = Standard DDC Processing, with Solder Dip, and Burn-In
9 = Standard DDC Processing, with Solder Dip, without Burn-In
- Temperature Grade/Data Requirements:
1 = -55°C to +125°C
4 = -55°C to +125°C, with Variables Test Data
- Package:
0 = 40-Pin DDIP, (" +5 volt only " power supply feature - not available)
2 = 44-Pin J-Lead

Notes:

1. The lead-free option is available with a matte-tin finish. DDC can provide the reliability and tin whisker growth data associated with these products; however, tin whisker growth is dependant on the application environment and customers should collect their own reliability data and perform a risk assessment based on their individual requirements.
2. (a) Parts marked with no revision after the date code are not lead free, plating is 85/15, 85% tin/15% lead.
(b) Parts marked with revision "B" after the date code are not lead free, and are completed by a solder dip process over a tin (Sn) plated lead. Final finish is 63/37, 63% tin/37% lead.

Packaging

RDC-19222/2S and RDC-19224 are shipped in JEDEC trays that are acceptable for use with pick and place operation.



The information in this Product Brief is believed to be accurate; however, no responsibility is assumed by Data Device Corporation for its use, and no license or rights are granted by implication or otherwise in connection therewith. Specifications are subject to change without notice.

For ordering assistance and technical support,

- Call: 1-800-DDC-5757 for North America
(631) 567-5700 for International
- E-Mail: service@ddc-web.com
- Visit: www.ddc-web.com
- Headquarters, N.Y., U.S.A - Tel: (631) 567-5600, Fax: (631) 567-7358
- United Kingdom - Tel: +44-(0)1635-811140, Fax: +44-(0)1635-32264
- France - Tel: +33-(0)1-41-16-3424, Fax: +33-(0)1-41-16-3425
- Germany - Tel: +49-(0)89-1500-12-11, Fax: +49(0)89-1500 12-22
- Japan - Tel: +81-(0)3-3814-7688, Fax: +81-(0)3-3814-7689
- Asia - Tel: +65-6489-4801

