

Low power VHF, UHF and hyperband mixer/oscillator for TV and VCR 3-band tuners

TDA5630

FEATURES

- Balanced mixer with a common emitter input for band A (single input)
- 2-pin oscillator for bands A and B
- Balanced mixer with a common base input for bands B and C (balanced input)
- 3-pin oscillator for band C
- Local oscillator buffer output for external synthesizer
- SAW filter preamplifier with a low output impedance to drive the SAW filter directly
- Band gap voltage stabilizer for oscillator stability
- Electronic band switch.

DESCRIPTION

The TDA5630 is a monolithic integrated circuit that performs the bands A, B and C mixer/oscillator functions in TV and VCR tuners. This low-power mixer/oscillator requires a power supply of 9 V and is available in a very small package.

The device gives the designer the capability to design an economical and physically small 3-band tuner.

The tuner development time can be drastically reduced by using this device. In addition, when hyperband is not necessary, the TDA5630 may be used in a VHF/UHF tuner with an appropriate tuned circuit for VHF I and VHF III in band A, and the tuned circuit of band C for UHF.

QUICK REFERENCE DATA

SYMBOL	PARAMETER	CONDITIONS	MIN.	TYP.	MAX.	UNIT
V_P	supply voltage		–	9.0	–	V
I_P	supply current		–	35	–	mA
f_{RA}	frequency range; band A	RF input	45	–	180	MHz
f_{RB}	frequency range; band B	RF input	160	–	470	MHz
f_{RC}	frequency range; band C	RF input	430	–	860	MHz
N_{ARA}	noise figure; band A		–	7.5	–	dB
N_B	noise figure; band B		–	8	–	dB
N_C	noise figure; band C		–	9	–	dB
V_{IA}	input voltage; band A	1% cross-modulation	–	93	–	dB μ V
V_{IB}	input voltage; band B	1% cross-modulation	–	82	–	dB μ V
V_{IC}	input voltage; band C	1% cross-modulation	–	82	–	dB μ V
G_v	voltage gain	band A	–	25	–	dB
		band B	–	36	–	dB
		band C	–	36	–	dB

ORDERING INFORMATION

TYPE NUMBER	PACKAGE		
	NAME	DESCRIPTION	VERSION
TDA5630T	SO20	plastic small outline package; 20 leads; body width 7.5 mm	SOT163-1
TDA5630M	SSOP20	plastic shrink small outline package; 20 leads; body width 4.4 mm	SOT266-1

Low power VHF, UHF and hyperband mixer/oscillator for TV and VCR 3-band tuners

TDA5630

BLOCK DIAGRAM

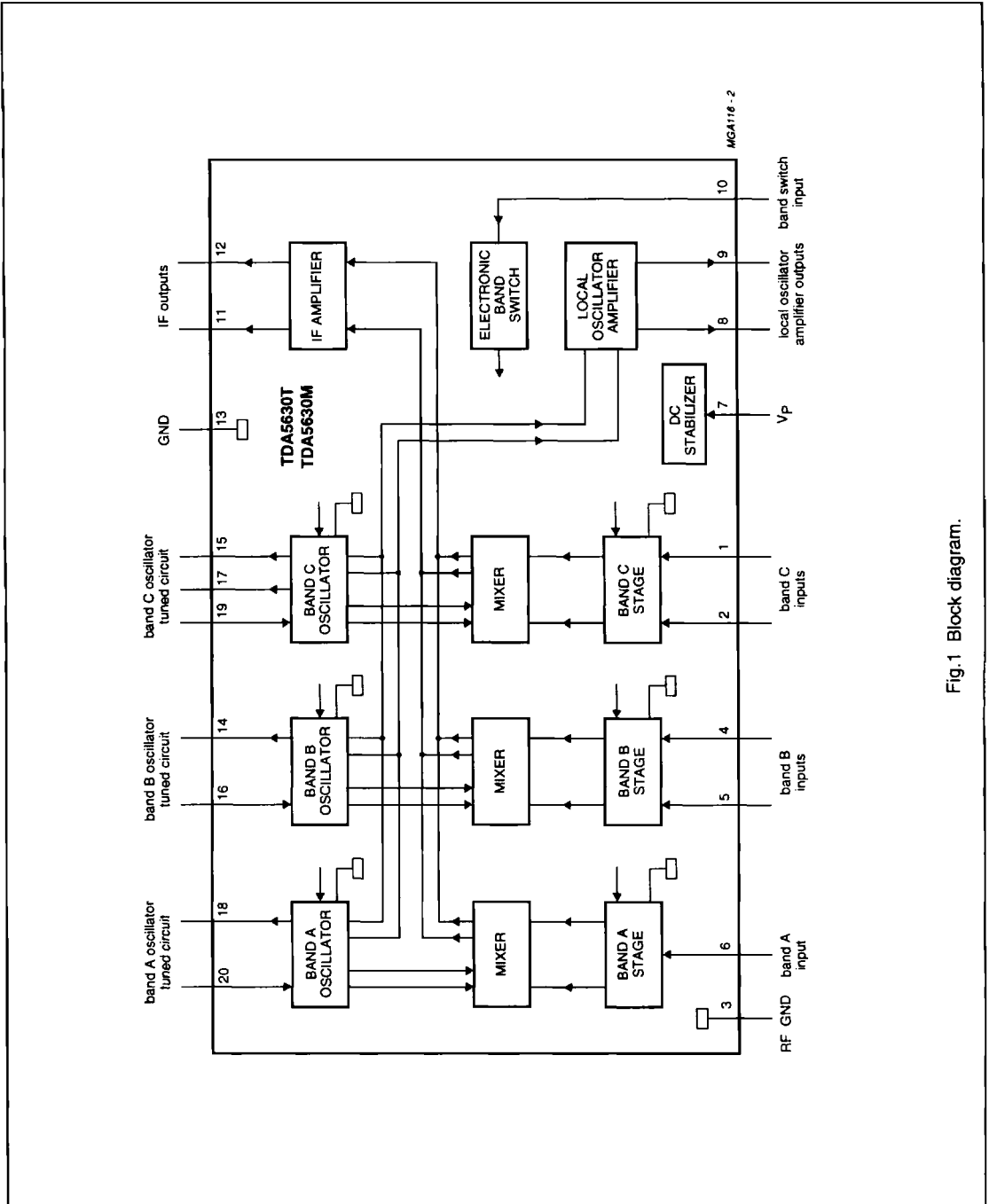

Fig. 1 Block diagram.

Low power VHF, UHF and hyperband mixer/oscillator for TV and VCR 3-band tuners

TDA5630

PINNING

SYMBOL	PIN	DESCRIPTION
CIN1	1	band C input 1
CIN2	2	band C input 2
RFGND	3	ground for RF inputs
BIN1	4	band B input 1
BIN2	5	band B input 2
AIN	6	band A input
V _P	7	supply voltage
LOOUT1	8	local oscillator amplifier output 1
LOOUT2	9	local oscillator amplifier output 2
BS	10	electronic bandswitch
IFOUT1	11	IF amplifier output 1
IFOUT2	12	IF amplifier output 2
GND	13	ground (0 V)
BOSCOC	14	band B oscillator output collector
COSCOC1	15	band C oscillator output collector 1
BOSCIB	16	band B oscillator input base
COSCOC2	17	band C oscillator output collector 2
AOSCOC	18	band A oscillator output collector
COSCIB	19	band C oscillator input base
AOSCIB	20	band A oscillator input base

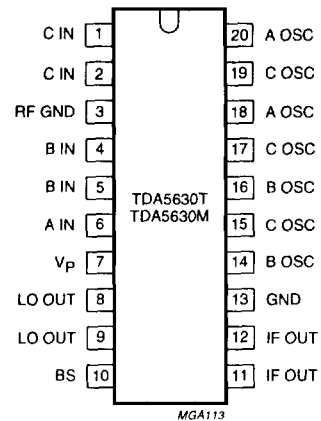

Fig.2 Pin configuration.

Low power VHF, UHF and hyperband mixer/oscillator for TV and VCR 3-band tuners

TDA5630

LIMITING VALUES

In accordance with the Absolute Maximum Rating System (IEC 134).

SYMBOL	PARAMETER	MIN.	MAX.	UNIT
V_P	supply voltage range	-0.3	+10.5	V
V_{SW}	switching voltage	0	10.5	V
I_O	output current of each pin to ground	-	-10	mA
t_{sc}	maximum short-circuit time (all pins)	-	10	s
T_{stg}	storage temperature	-55	+150	°C
T_{amb}	operating ambient temperature	-10	+80	°C
T_j	junction temperature	-	150	°C

THERMAL CHARACTERISTICS

SYMBOL	PARAMETER	VALUE	UNIT
$R_{th\ j-a}$	thermal resistance from junction to ambient in free air		
	SOT163-1	100	K/W
	SOT266-1	120	K/W

HANDLING

Human body model: the IC withstands 3000 V in accordance with UZW-BO-FQ-A302 (stress reference pins 3 and 13 shorted together).

Machine model: the IC withstands 200 V in accordance with UZW-BO-FQ-B302 (stress reference pins 3 and 13 shorted together).

IF AMPLIFIER CHARACTERISTICS

$V_P = 9\text{ V}$; $T_{amb} = 25\text{ °C}$; measured at 36 MHz; measured in circuit of Fig.4; unless otherwise specified.

SYMBOL	PARAMETER	CONDITIONS	MIN.	TYP.		MAX.	UNIT
				MOD.	PHASE		
S_{22}	output reflection coefficient	see Fig.9	-	-10	9	-	dB ⁰
Z_o	output impedance ($R_s + jL_s\Omega$)	R_s	-	95	-	-	Ω
		L_s	-	45	-	-	nH

Low power VHF, UHF and hyperband mixer/oscillator for TV and VCR 3-band tuners

TDA5630

CHARACTERISTICS $V_P = 9\text{ V}$; $T_{\text{amb}} = 25\text{ }^\circ\text{C}$; measured in circuit of Fig.4; unless otherwise specified.

SYMBOL	PARAMETER	CONDITIONS	MIN.	TYP.	MAX.	UNIT
Supply						
V_P	supply voltage		8.1	9	9.9	V
I_P	supply current		–	35	45	mA
V_{sw}	switching voltage	band A	0	–	1.1	V
		band B	1.6	–	2.4	V
		band C	3.0	–	5.0	V
I_{sw}	switching current	band A	–	–	2	μA
		band B	–	–	5	μA
		band C	–	–	10	μA
Band A mixer (pin 6)						
f_R	frequency range		45	–	180	MHz
N	noise figure	50 MHz; see Fig.3	–	7.5	9	dB
		180 MHz; see Fig.3	–	9	10	dB
g_{os}	optimum source conductance for noise figure	50 MHz	–	0.5	–	mS
		180 MHz	–	1.1	–	mS
g_i	input conductance	50 MHz; see Fig.5	–	0.26	–	mS
		180 MHz; see Fig.5	–	0.35	–	mS
C_i	input capacitance	50 to 180 MHz	–	2	–	pF
V_i	input voltage	1% cross modulation; in channel $f = 180\text{ MHz}$	90	93	–	dB μV
		10 kHz pulling; in channel $f = 180\text{ MHz}$	–	100	–	dB μV
G_v	voltage gain	20 log (V_{12-11}/V_6) ; 50 MHz	22.5	25	27.5	dB
		20 log (V_{12-11}/V_6) ; 180 MHz	22.5	25	27.5	dB
Band A oscillator						
f_R	frequency range		80	–	216	MHz
f_{shift}	frequency shift	$\Delta V_P = 10\%$; note 1	–	–	200	kHz
f_{drift}	frequency drift	$\Delta T = 25\text{ }^\circ\text{C}$ with no compensation; NP0NPO capacitors; note 2	–	–	500	kHz
		5 s to 15 min after switch on; note 2	–	–	200	kHz

Low power VHF, UHF and hyperband
mixer/oscillator for TV and VCR 3-band tuners

TDA5630

SYMBOL	PARAMETER	CONDITIONS	MIN.	TYP.	MAX.	UNIT
Band B mixer (pins 4 and 5; including IF amplifier); measurements using hybrid; note 3						
f_R	frequency range		160	–	470	MHz
N	noise figure (not corrected for image)	170 MHz	–	8	10	dB
		470 MHz	–	8	10	dB
Z_i	input impedance ($R_S + jL_S\Omega$)	R_S ; see Fig.6	–	30	–	Ω
		L_S ; see Fig.6		8		nH
V_i	input voltage	1% cross-modulation; in channel; 170 MHz	79	82	–	dB μ V
		1% cross-modulation; in channel; 470 MHz	79	82	–	dB μ V
		10 kHz pulling; in channel; 470 MHz; TDA5630T	–	91	–	dB μ V
		10 kHz pulling; in channel; 470 MHz; TDA5630M	–	83	–	dB μ V
		N + 5 – 1 MHz pulling; 430 MHz; TDA5630T; note 4	–	81	–	dB μ V
		N + 5 – 1 MHz pulling; 430 MHz; TDA5630M; note 4	–	66	–	dB μ V
G_v	voltage gain	170 MHz; note 5	33	36	39	dB
		470 MHz; note 5	33	36	39	dB
Band B oscillator						
f_R	frequency range		200	–	500	MHz
f_{shift}	frequency shift	$\Delta V_P = 10\%$; note 1	–	–	400	kHz
f_{drift}	frequency drift	$\Delta T = 25^\circ\text{C}$ with no compensation; NP0 capacitors; note 2	–	–	2	MHz
		5 s to 15 min after switch on; note 2	–	–	300	kHz
Band C mixer (pins 1 and 2; including IF amplifier); measurements using hybrid; note 3						
f_R	frequency range		430	–	860	MHz
N	noise figure (not corrected for image)	430 MHz	–	9	11	dB
		860 MHz	–	9	11	dB
Z_i	input impedance ($R_S + jL_S\Omega$)	R_S ; 430 MHz; see Fig.7	–	40	–	Ω
		R_S ; 860 MHz; see Fig.7	–	53	–	Ω
		L_S ; 430 to 860 MHz	–	9	–	nH
V_i	input voltage	1% cross-modulation; in channel; 430 MHz	79	82	–	dB μ V
		1% cross-modulation; in channel; 860 MHz	79	82	–	dB μ V
		10 kHz pulling; in channel; 860 MHz; TDA5630T	–	87	–	dB μ V
		10 kHz pulling; in channel; 860 MHz; TDA5630M	–	93	–	dB μ V
		N + 5 – 1 MHz pulling; 820 MHz; note 4	–	61	–	dB μ V

Low power VHF, UHF and hyperband mixer/oscillator for TV and VCR 3-band tuners

TDA5630

SYMBOL	PARAMETER	CONDITIONS	MIN.	TYP.	MAX.	UNIT
G_v	voltage gain	430 MHz; note 5	33	36	39	dB
		860 MHz; note 5	33	36	39	dB
Band C oscillator						
f_R	frequency range		470	–	900	MHz
f_{shift}	frequency shift	$\Delta V_P = 10\%$; note 1	–	–	400	kHz
f_{drift}	frequency drift	$\Delta T = 25^\circ\text{C}$ with no compensation; NP0 capacitors; note 2	–	–	2.5	MHz
		5 s to 15 min after switching on; note 2	–	–	600	kHz
LO output (pins 8 and 9; $R_L = 100\ \Omega$)						
S_{22}	output reflection coefficient	see Fig.8				
V_O	output voltage		14	35	100	mV
SRF	spurious signal on LO output w.r.t. LO output signal	note 7	–	–	–10	dB
SHD	LO signal harmonics w.r.t. LO signal		–	–	–10	dB

Notes

- The frequency shift is defined for a variation of power supply, first from $V_P = 9$ to 8.1 V, then from $V_P = 9$ to 9.9 V. In both cases, the frequency shift is below the specified value.
- The frequency drift is defined for a variation of ambient temperature, first from $T_{\text{amb}} = 25^\circ\text{C}$ to $T_{\text{amb}} = 0^\circ\text{C}$, then from $T_{\text{amb}} = 25^\circ\text{C}$ to $T_{\text{amb}} = 50^\circ\text{C}$. In both cases, the frequency drift is below the specified value with NP0 capacitors. Capacitor types C1 to C11, as specified in Fig.4 for non-PLL applications, must be changed to series with other temperature coefficients (e.g. N330, N750 etc.).
- The values have been corrected for hybrid and cable losses. The symmetrical output impedance of the circuit is $100\ \Omega$.
- The input level of a $N + 5 - 1$ MHz signal which gives a signal 30 dB below the oscillator carrier at the LO output.
- The gain is defined as the transducer gain (measured in Fig.4) plus the voltage transformation ratio of L6 to L7 (6 : 1, 15.4 dB).
- Measured at $50\ \Omega$, with RF input voltage:
 - RF voltage = $120\ \text{dB}\mu\text{V}$ at $f < 180$ MHz
 - RF voltage = $107.5\ \text{dB}\mu\text{V}$ at $180\ \text{MHz} < f < 225$ MHz
 - RF voltage = $97\ \text{dB}\mu\text{V}$ at $225\ \text{MHz} < f < 860$ MHz.
- All S-parameters are referred to a $50\ \Omega$ system.

Low power VHF, UHF and hyperband mixer/oscillator for TV and VCR 3-band tuners

TDA5630

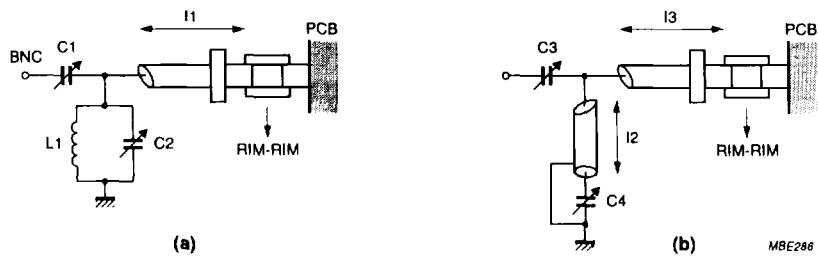
**(a) For $f_R = 50$ MHz:**

mixer A frequency response measured = 57 MHz, loss = 0 dB
image suppression = 16 dB

$C1 = 9$ pF

$C2 = 15$ pF

$L1 = 7$ turns (Δ 5.5 mm, wire diam. = 0.5 mm)

$I1 =$ rigid cable (RIM): 5 cm long

(rigid cable (RIM): 33 dB/100 m; 50 Ω ; 96 pF/m).

(b) For $f_R = 180$ MHz:

mixer A frequency response measured = 150.3 MHz, loss = 1.3 dB
image suppression = 13 dB

$C3 = 5$ pF

$C4 = 25$ pF

$I2 =$ rigid cable (RIM): 30 cm long

$I3 =$ rigid cable (RIM): 5 cm long

(rigid cable (RIM): 33 dB/100 m; 50 Ω ; 96 pF/m).

Fig.3 Input circuit for optimum noise figure.

Low power VHF, UHF and hyperband mixer/oscillator for TV and VCR 3-band tuners

TDA5630

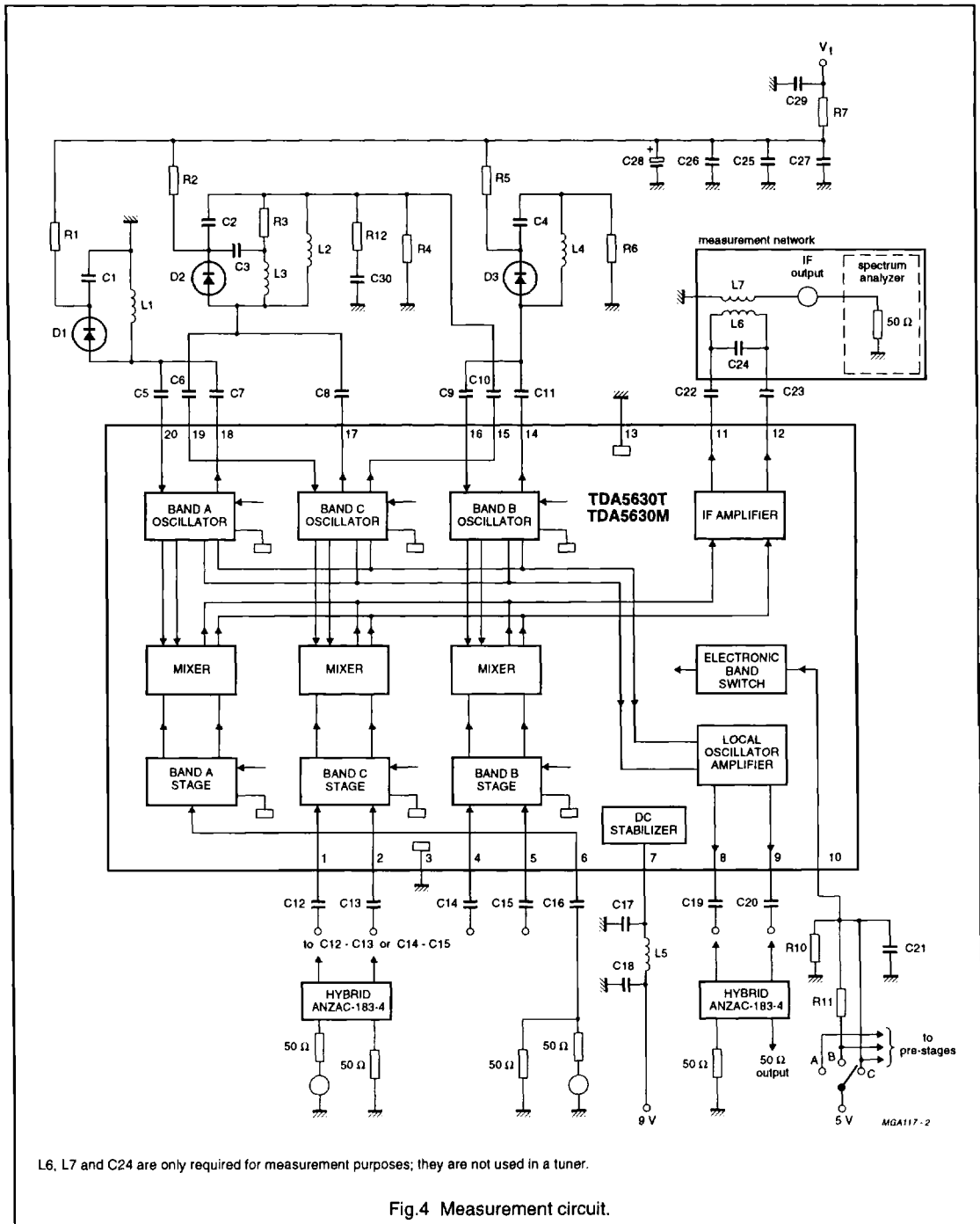

Low power VHF, UHF and hyperband mixer/oscillator for TV and VCR 3-band tuners

TDA5630

Component values for measurement circuit

Table 1 Capacitors (all SMD and NP0 except C28)

COMPONENT	VALUE
C1	82 pF
C2	5.6 pF
C3	100 pF
C4	150 pF
C5	2.2 pF
C6	1 pF
C7	2.2 pF
C8	1 pF
C9	1.8 pF
C10	2.2 pF
C11	3.9 pF
C12	1 nF
C13	1 nF
C14	1 nF
C15	1 nF
C16	1 nF
C17	1.5 nF
C18	1.5nF
C19	1 nF
C20	1 nF
C21	1.5 nF
C22	1 nF
C23	1 nF
C24	18 pF
C25	1.5 nF
C26	1.5 nF
C27	1.5 nF
C28	1 μ F; 40 V electrolytic
C29	1.5 nF
C30	0.56 pF

Table 2 Resistors (all SMD)

COMPONENT	VALUE
R1	47 k Ω
R2	22 k Ω
R3	2.2 k Ω
R4	22 k Ω
R5	47 k Ω
R6	22 Ω
R7	1 k Ω
R10	15 k Ω
R11	36 k Ω
R12	470 Ω

Table 3 Diodes and IC

COMPONENT	VALUE
D1	BB911
D2	BB405/215
D3	BB909/219
IC	TDA5630T/TDA5630M

Table 4 Coils (wire size 0.4 mm)

COMPONENT	VALUE
L1	7.5 turns; dia. 3 mm
L2	2.5 turns; dia. 3 mm
L3	1.5 turns; dia. 2.5 mm
L4	1.5 turns; dia. 4 mm
L5	4.7 μ H; choke coil

Table 5 Transformers; note 1

COMPONENT	VALUE
L6	2 \times 5 turns
L7	2 turns

Note

- Coil type: TOKO 7 kN; material: 113 kN; screw core 03-0093; pot core 04-0026.

Low power VHF, UHF and hyperband
 mixer/oscillator for TV and VCR 3-band tuners

TDA5630

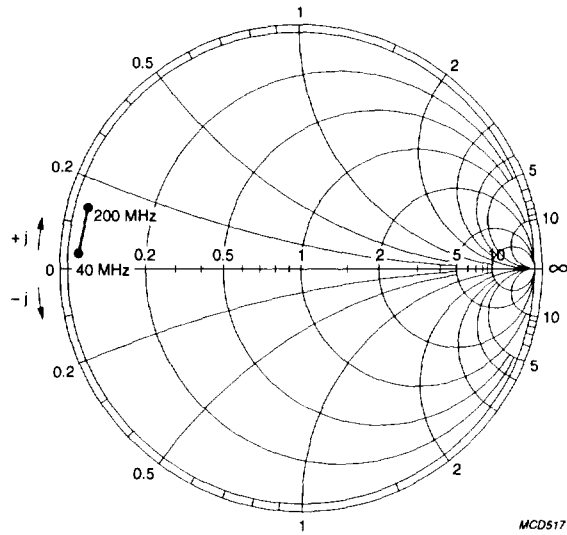

Fig.5 Input admittance (S_{11}) of the band A mixer input (40 to 200 MHz) (Y chart).

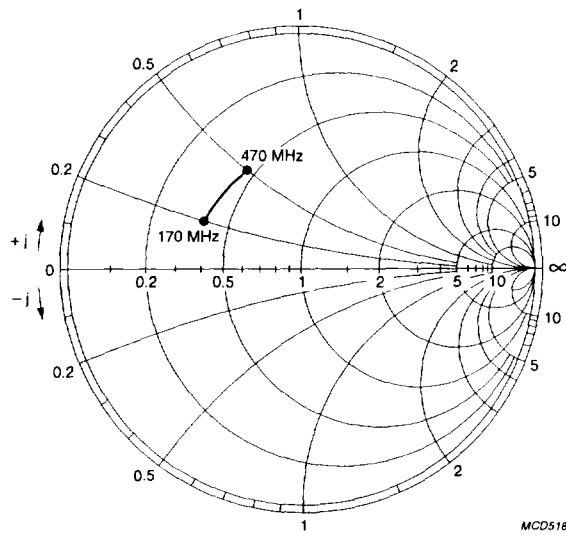
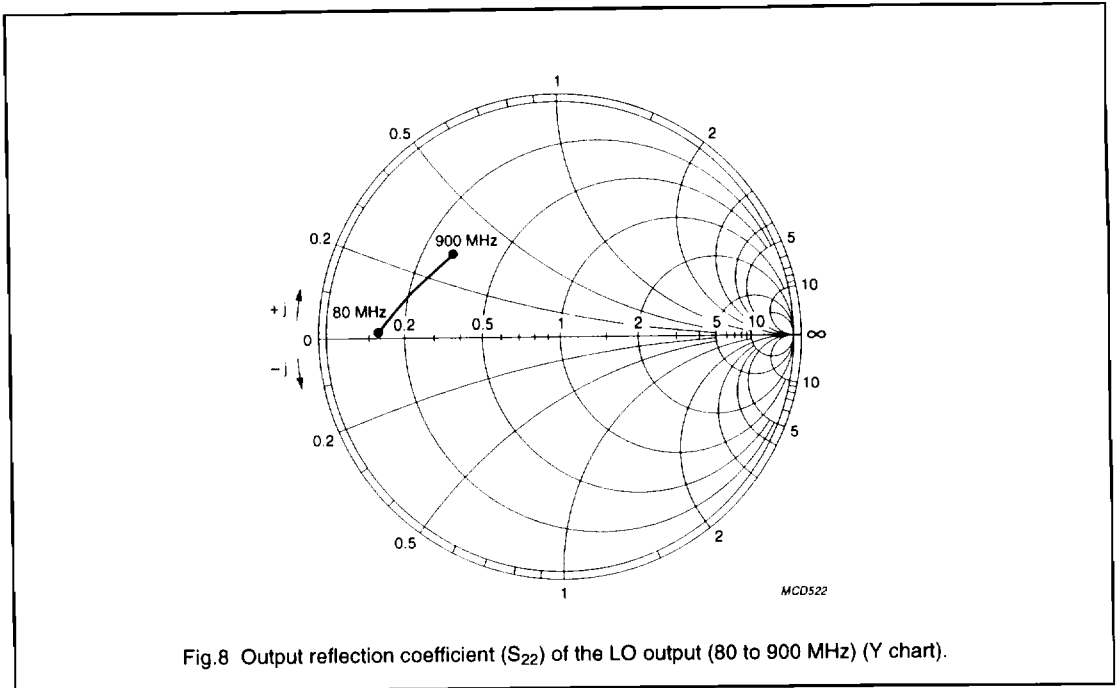
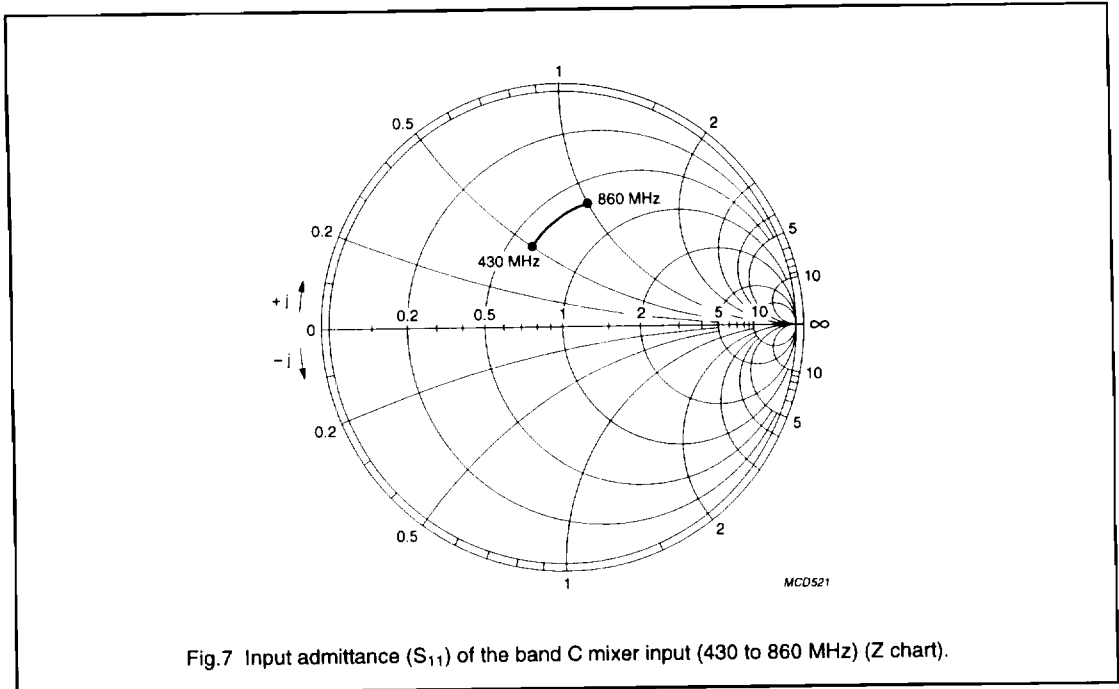

Fig.6 Input admittance (S_{11}) of the band B mixer input (170 to 470 MHz) (Z chart).

Low power VHF, UHF and hyperband
 mixer/oscillator for TV and VCR 3-band tuners

TDA5630



Low power VHF, UHF and hyperband
 mixer/oscillator for TV and VCR 3-band tuners

TDA5630

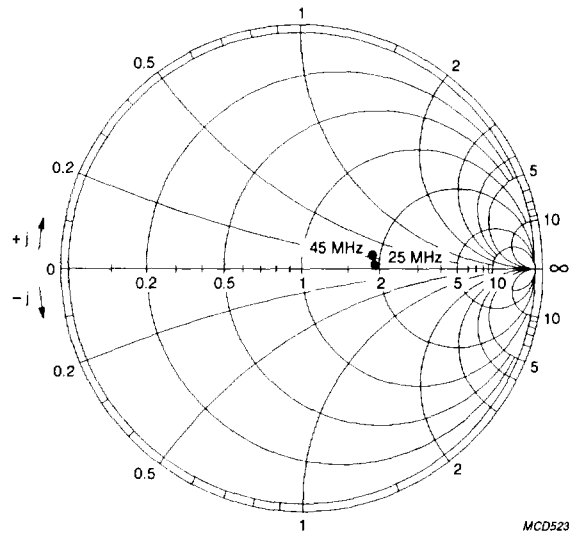

Fig.9 Output reflection coefficient (S_{22}) of the IF amplifier (25 to 45 MHz) (Z chart).