

## DESCRIPTION

AMCOM's AM183031WM-BM/FM-R is part of the GaAs MMIC power amplifier series. It has 31.5dB gain and 31.5dBm output power over the 1.6 to 3.3GHz band. This MMIC is in a ceramic package with both RF and DC leads at the lower level of the package to facilitate low-cost SMT assembly to the PC board. When mounting directly to PCB, please see application note AN700 for instructions. Because of high DC power dissipation, we strongly recommend to mount these devices directly on a metal heat sink. The AM183031WM-FM-R is the AM183031WM-BM-R mounted on a gold plated copper flange carrier. There are two screw holes on the flange to facilitate screwing on to a metal heat sink. This MMIC is RoHS compliant.

## FEATURES

- Wide bandwidth from 1.6 to 3.3GHz
- High output power, P1dB = 31.5dBm
- High gain, 31.5dB
- Fully matched; 50-ohm input/output impedance

## APPLICATIONS

- Wireless Internet Access
- Wireless Local Loop
- MMDS

## PERFORMANCE\* (Vds = 8V, Idq = 670mA, TA = 25°C)

Parameters	Minimum	Typical	Maximum
Frequency	1.8 – 3.0GHz	1.6 – 3.3GHz	
Gain (Small signal)	26.5dB	31.5dB	
Gain Ripple		± 1.0dB	± 2.0dB
P1dB	30.5dBm	31.5dBm	
P3dB	31.0dBm	32.5dBm	
IP3	38.0dBm	40.0dBm	
Efficiency	20%	25%	
Input Return Loss	15dB	18dB	
Output Return Loss	10dB	12dB	
Thermal Resistance		11.7°C/W	

\* Specifications subject to change without notice.

### ABSOLUTE MAXIMUM RATING

Parameter	Symbol	Rating
Drain source voltage	Vds	10V
Gate source voltage	Vgs	-5V
Drain source current	I <sub>ds</sub>	1.3A
Continuous dissipation at room temperature	P <sub>t</sub>	12.8W
Channel temperature	T <sub>ch</sub>	175°C
Storage temperature	T <sub>sto</sub>	-55°C to +135°C

### SMALL SIGNAL DATA

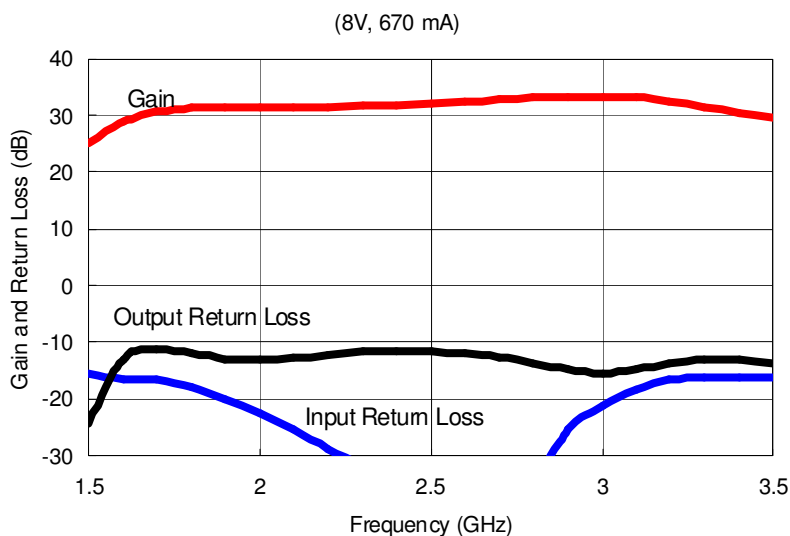

### POWER DATA

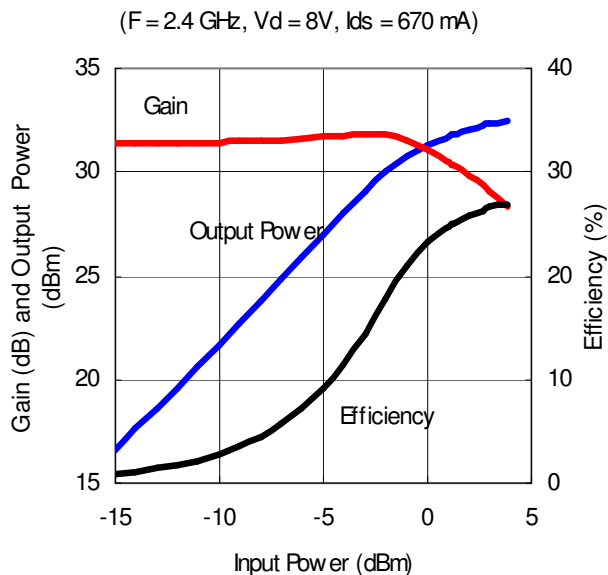
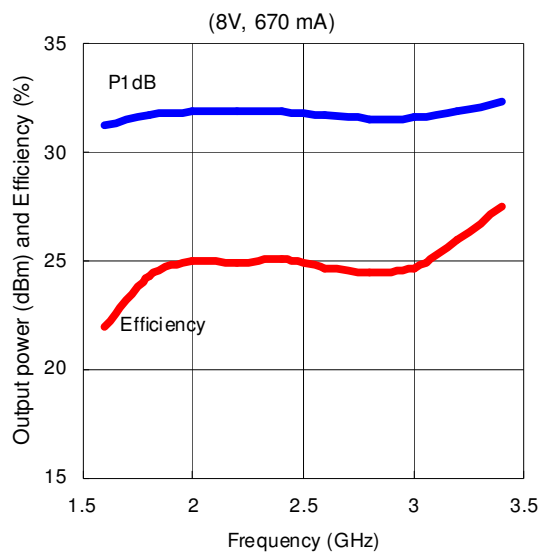

**PACKAGE OUTLINE**

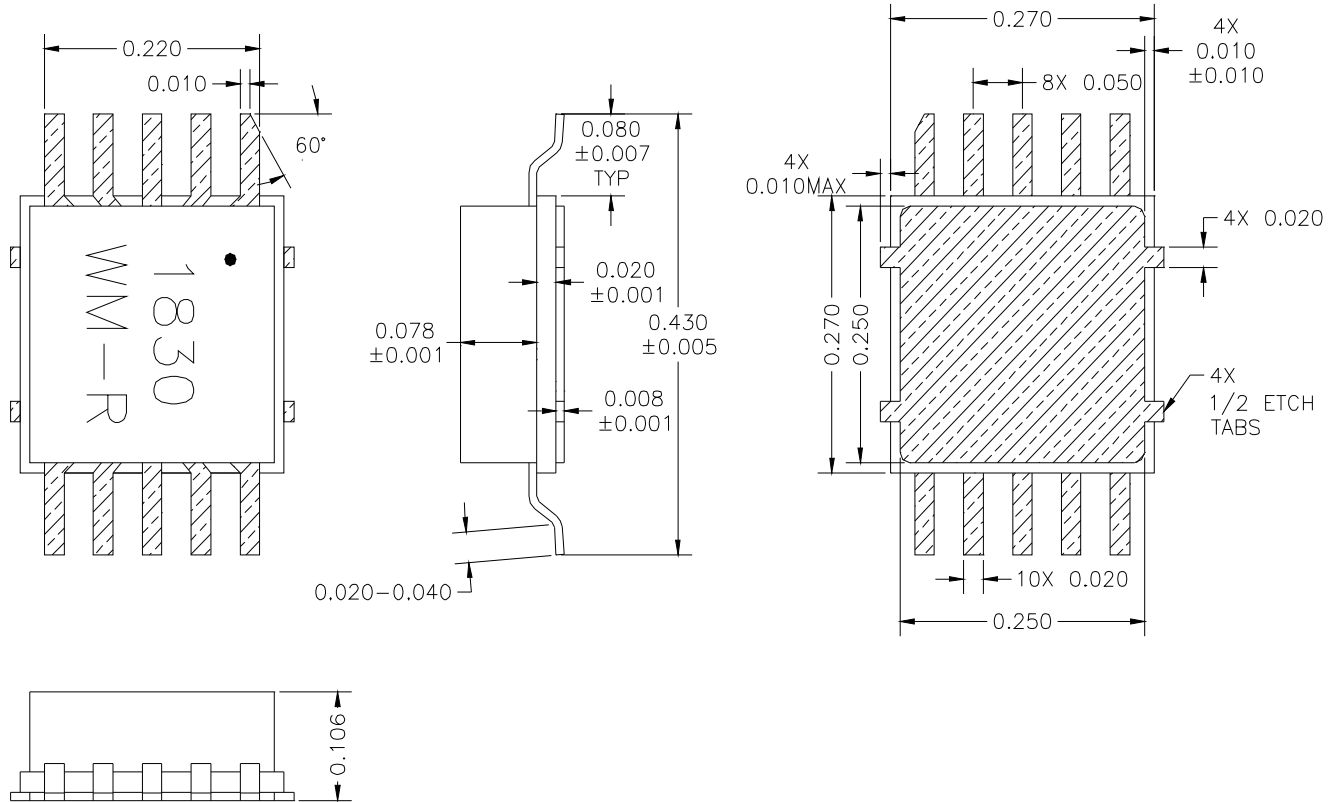

**PIN LAYOUT**

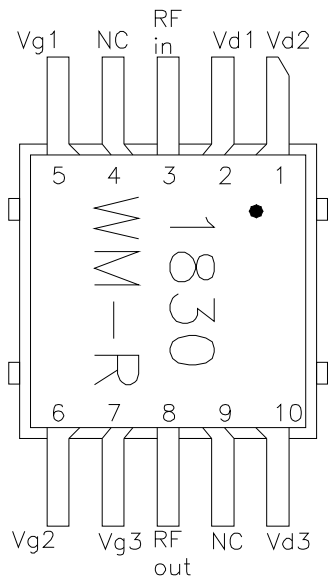

Pin No.	Function
1	Vd2
2	Vd1
3	RF in
4	NC
5	Vg1
6	Vg2
7	Vg3
8	RF
9	NC
10	Vd3

\* Gate voltage may vary from lot to lot

PACKAGE OUTLINE (FM)

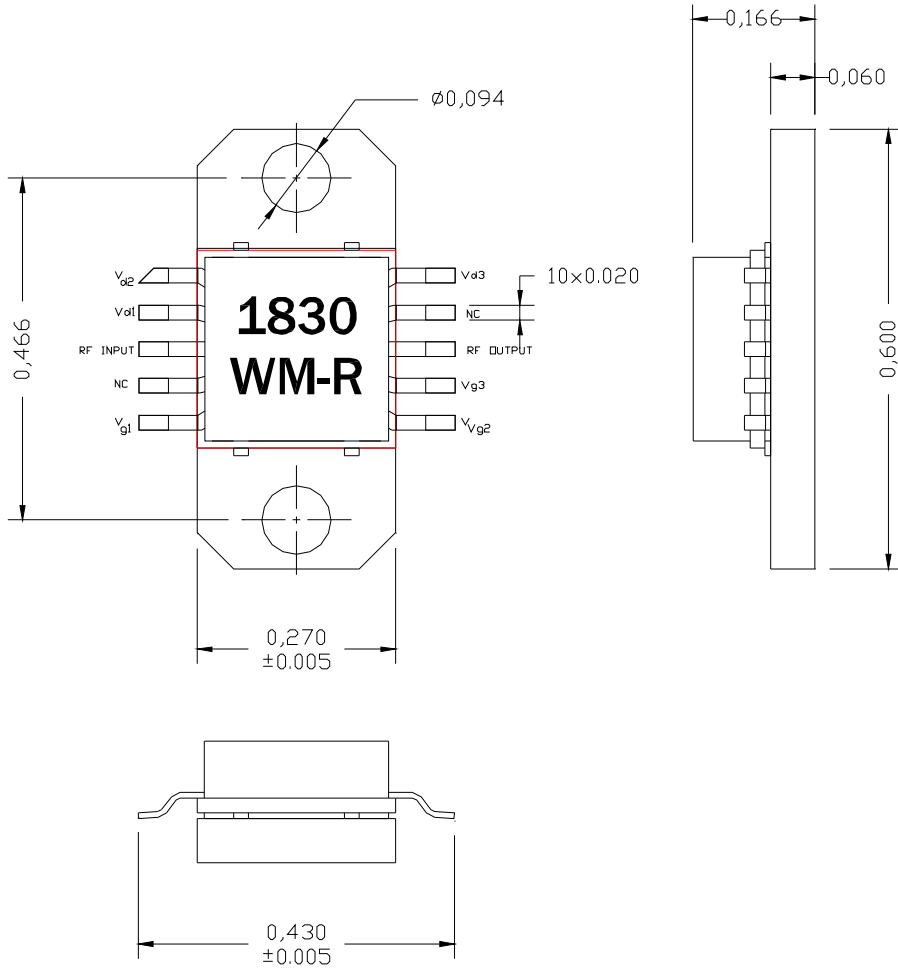

PIN LAYOUT

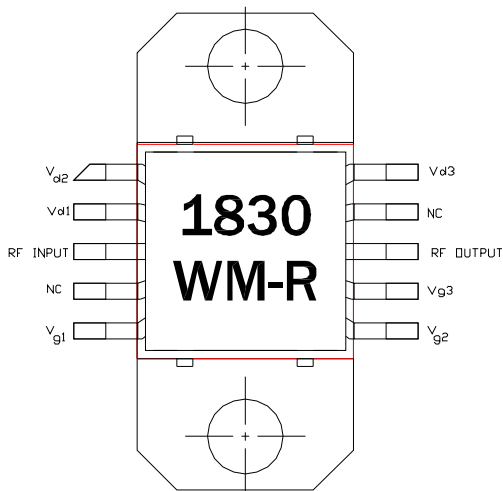

Pin No.	Function
1	Vd2
2	Vd1
3	RF in
4	NC
5	Vg1
6	Vg2
7	Vg3
8	RF
9	NC
10	Vd3

\* Gate voltage may vary from lot to lot

TEST CIRCUIT OUTLINE for BM Package

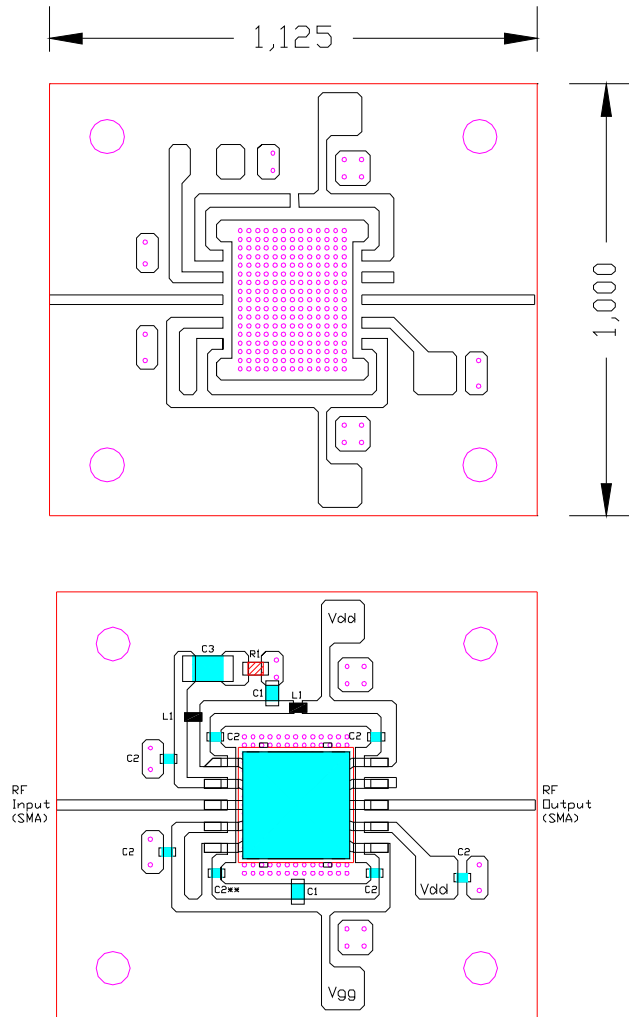

Notes:  
 1- 10mils Rogers 4350 Material epoxied to D0007-0021A  
 2- Ckt is for matched MMICs  
 3- C1=0.56uF (0603), C2=1000pF (0402), C3=10uF (1206), R1=3 ohms (0603), L1=1nH (0402), \*\* May be omitted

Important Notes:

- 1- The MMIC should have a good heat sink to avoid overheating. If SMT is used use PC board thickness  $\leq 10$  mils and ensure vias are filled with solder or metal to lower PCB heat resistance. MMIC could be attached on direct ground for lowest junction temperature.
- 2- Recommended current biases are 70mA, 150mA & 450mA for the first, second and third stages respectively.
- 3- Do not apply  $V_{ds1}$ ,  $V_{ds2}$  &  $V_{ds3}$  without proper negative voltages on  $V_{gs1}$ ,  $V_{gs2}$  &  $V_{gs3}$ .
- 4- The currents flowing out of the  $V_{gs1}$ ,  $V_{gs2}$  &  $V_{gs3}$  pins are less than 70 $\mu$ A, 150 $\mu$ A & 3mA at  $P_{1dB}$ .
- 5- External 1  $\mu$ F dipped tantalum capacitor should be attached to Vd and Vg to decouple external bias leads.

TEST CIRCUIT for FM package

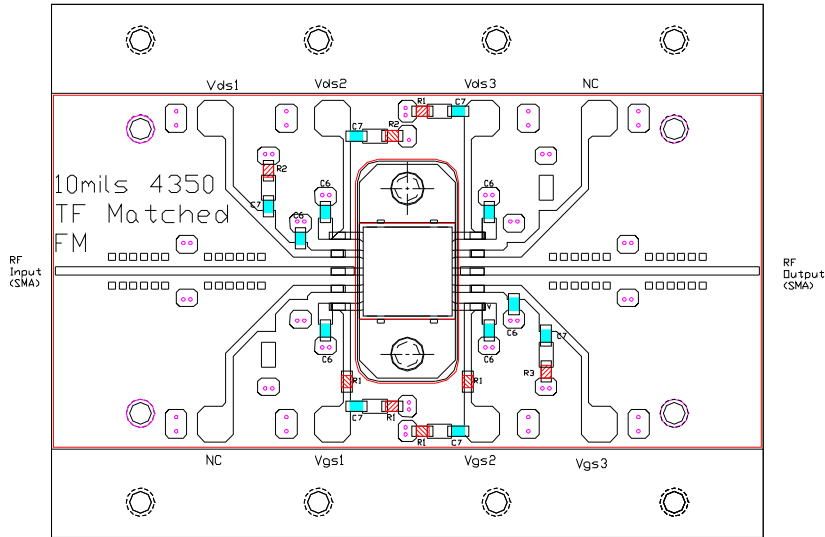

- Notes:
- 1- 10mils Rogers 4350 Material epoxied
  - 2- Ckt is for matched MMICs
  - 3- C6=20pF, C7=1000pF,  
 R1=50ohms, R2=10ohms, R3=5ohms
  - 4- All Caps & Resistors are 0603 size
  - 5- External 1  $\mu$ F dipped tantalum capacitor should be attached to Vd and Vg to decouple external bias leads.