

# M-984-02 Special Information Tone Detector

- Detects single-frequency tones used for error indication and call progress in telephone systems
- Provides detection windows for:  
 400/425 Hz (Call Progress)  
 950 Hz (Special and error indication)  
 1400 Hz (Special and error indication)  
 1800 Hz (Special and error indication)
- Separate tri-state outputs for each tone window
- Inexpensive 3.58 MHz crystal time base
- Auxiliary 3.58 MHz clock output
- 14-pin DIP package and 16-pin SOIC package
- Single supply 3 to 5 volt (low power CMOS)
- Wide dynamic range (30 dBm)
- Applications include: automatic dialers, modems, telecom test equipment, telephone traffic measurement, service evaluation, billing equipment

The Teltone M984-02 Special Information Tone Detector is a monolithic integrated circuit designed to provide reliable detection of many common telephone network status signals. In particular, it detects the signals known as Special information Tones (SITs) or error tones as defined by the CCITT, and single tones often used as dial tone, audible ringing, and other general progress indications. The M-984-02 uses CMOS switched capacitor filters and a crystal time base to achieve the high stability and accuracy specified. Each tone detection window has an associated output pin, which can be placed in a high impedance state for use with time-share microcomputer bus applications.

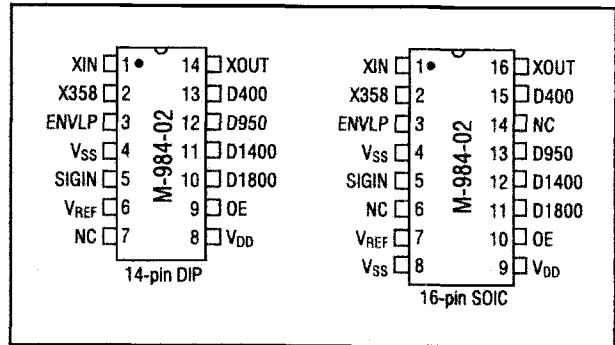

Figure 1 Pin Diagram

In comparison with the earlier M-984, the M-984-02 has wider acceptance bands for SIT tones to facilitate reception of tape-loop tones, lower power consumption at 5V operation, 3V operation, superior temperature performance, lower cost, and is available in DIP, SOIC, and SOIC tape and reel versions.

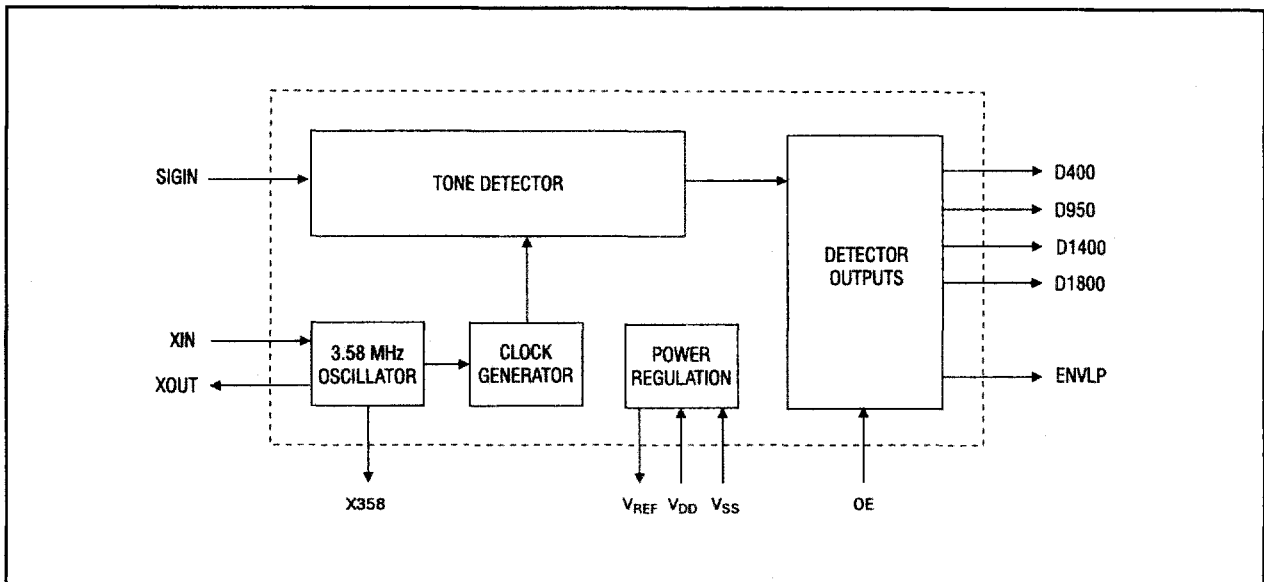

Figure 2 Block Diagram

Table 1 Pin Functions

Pin	Function
XIN	Crystal Connection — 3.58 MHz crystal across these pins will produce the timebase needed for proper operation of the M-984-02.
XOUT	An external clock signal may be fed to XIN providing the clock signal has a duty cycle of $50 \pm 10\%$ and comes within 0.2 volts of the supply rails. XOUT remains unconnected when an external clock is used.
X358	A buffered output pin. A 3.58 MHz clock signal is available for use in other circuits as a timebase. Leave open when unused.
ENVLP	The ENVLP pin is a common detection indicator for the four detect pins. Simply put, the ENVLP is a logical "OR" of the active detect circuits for each of the four windows, though there is a delay provided to permit ENVLP to latch the first active detect pin. ENVLP is not 3-state controlled.
V <sub>SS</sub>	The power supply pins. V <sub>DD</sub> being the most positive. Commonly, V <sub>DD</sub> is at 3-5 volts, while V <sub>SS</sub> is at ground.
V <sub>DD</sub>	
SIGIN	Analog signal input. (Internally capacitively coupled.)
V <sub>REF</sub>	V <sub>REF</sub> is a bias voltage generated in the chip for use in external analog circuits, such as active filters and AC-coupled buffers. Leave open when unused.
OE	The tri-state control pin. OE places the DET pins in the active mode when at logic "1". When at logic "0," OE causes the DET outputs to appear as high impedance. Should be tied to logic "1" when the M-984-02 is not used in a time-shared bus application.
D1800	
1400	The detect outputs associated with each window. 3-state control is available through use of the OE pin 9.
D950	Timing is shown in Figure 4.
D400	

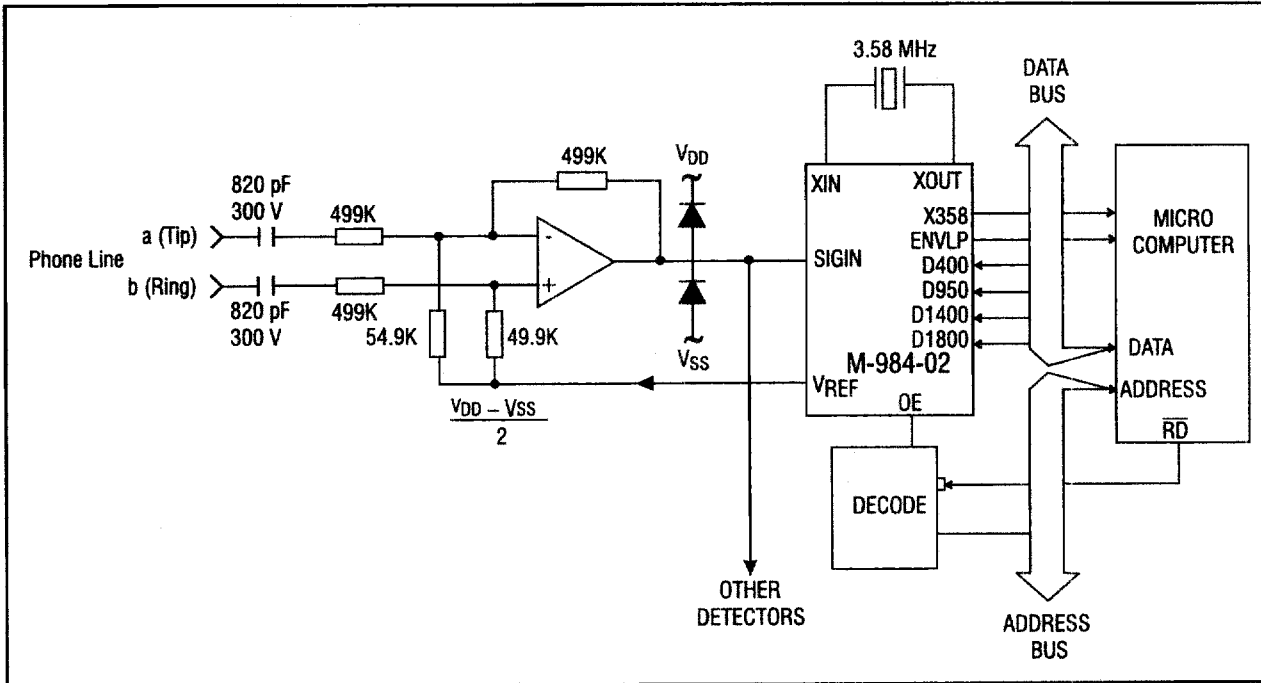

Figure 3 Typical Application

Table 2 Specifications

Parameter		Conditions	Min	Max	Units		
Operating Conditions	V <sub>DD</sub>	-	2.7	5.5	V		
	Power supply noise	0.1 - 5 kHz	-	20	mV p-p		
Power	Current drain (I <sub>DD</sub> )	V <sub>REF</sub> open	-	15	mA		
V <sub>REF</sub>	V <sub>REF</sub>	-	48% of V <sub>DD</sub>	52% of V <sub>DD</sub>	V		
	Impedance	-	3.25	8.25	KΩ		
Signal Detection	Frequency Range	-	Note 1	Note 1			
	Level: V <sub>DD</sub> = 5.0V	-	-30 (24.5 mV)	0 (775 mV)	dBm		
	Level: V <sub>DD</sub> = 3.0V	-	-33 (17.4 mV)	-3 (173.5 mV)	dBm		
	Duration	f <sub>c</sub> = 400 Hz	-	85	-	ms	
		f <sub>c</sub> = 950, 1400, 1800 Hz	-	50	-	ms	
	Bridge Time	-	-	15	ms		
Signal to Noise Ratio	-	-	16	-	dB		
Signal Rejection	Frequency Range	-	Note 1	Note 1			
	Level: V <sub>DD</sub> = 5.0V	-	-	-40 (7.8 mV)	dBm		
	Level: V <sub>DD</sub> = 3.0V	-	-	-43 (5.5 mV)	dBm		
	Duration	-	-	50	ms		
Outputs	Except X358	V <sub>OL</sub>	I <sub>SINK</sub> = -1.0 mA	-	0.5	V	
		V <sub>OH</sub>	I <sub>SOURCE</sub> = 1.0 mA	V <sub>DD</sub> -0.5	-	V	
	Dn pins only	I <sub>OZ</sub>	V <sub>O</sub> = V <sub>DD</sub> , V <sub>SS</sub>	-	1	μA	
Inputs	EN pin	V <sub>IL</sub>	-	-	0.5	V	
		V <sub>IH</sub>	V <sub>DD</sub> = 5V	V <sub>DD</sub> -2.0	-	V	
	Pull-up and Pull-down currents	MODE = V <sub>SS</sub>	V <sub>DD</sub> = 5V	-	12.5	50	μA
			V <sub>DD</sub> = 2.7V	-	4	20	μA
		/XRANGE +V <sub>SS</sub>	-	2	6	μA	
		MODE2 = V <sub>DD</sub>	V <sub>DD</sub> = 5V	-	12.5	100	μA
			V <sub>DD</sub> = 2.7V	-	12.5	25	μA
	PD = V <sub>DD</sub>	-	4	10	μA		
	SIGIN pin	Voltage range	-	-6.5	V <sub>DD</sub>	V	
		Input impedance	f = 500 Hz	80	-	KΩ	
Input Spectrum		-	-	28	kHz		
Clock	External clock connected to XIN pin	V <sub>IL</sub>	XOUT open	-	0.2	V	
		V <sub>IH</sub>	XOUT open	V <sub>DD</sub> - 0.2	-	V	
		Duty cycle	XOUT open	40	60	%	
	XIN, XOUT with crystal ocs. active	Capacitance	-	-	10	pF	
		Internal res.	-	20	-	MΩ	
	X358 pin	V <sub>OL</sub>	C <sub>L</sub> = 20 pF, I <sub>SINK</sub> = -1.0 mA	-	0.5	V	
		V <sub>OH</sub>	C <sub>L</sub> = 20 pF, I <sub>SOURCE</sub> = 1.0 mA	V <sub>DD</sub> - 0.5	-	V	
Duty cycle		C <sub>L</sub> = 20 pF	40	60	%		
Tri-state Operation	t <sub>EN</sub> (High Z to Low Z)	C <sub>L</sub> = 50 pF	-	250	ns		
	t <sub>DE</sub> (Low Z to High Z)	R <sub>L</sub> = 100 KΩ	-	250	ns		

Unless otherwise noted, specifications hold over V<sub>DD</sub> - V<sub>SS</sub> = 2.8V to 5.5V power supply, and T<sub>OL</sub> -40°C to +85°C.

**Notes:**  
1. See Table 3 for detection/rejection frequencies.

Table 3 Detector Frequency Windows

Detector	Low Reject	Low Accept	High Accept	High Reject
D400	363	392	459	493
D950	835	885	1016	1070
D1400	1275	1328	1472	1527
D1800	1656	1722	1854	1924

Table 4 Absolute Maximum Ratings

DC Supply Voltage	7V
Input Voltage on SIGIN	$V_{SS} - 6.5V$ to $V_{DD} + 0.3V$
Input Voltage on Any Pin (except SIGIN)	$V_{SS} - 0.3$ to $V_{DD} + 0.3V$
Storage Temperature Range	$-40^{\circ}C$ to $+150^{\circ}C$
Operating Temperature Range	$-40^{\circ}C$ to $+85^{\circ}C$
Lead Soldering Temperature	$260^{\circ}C$ for 5 seconds

**Note:**  
Exceeding these ratings may permanently damage the device.

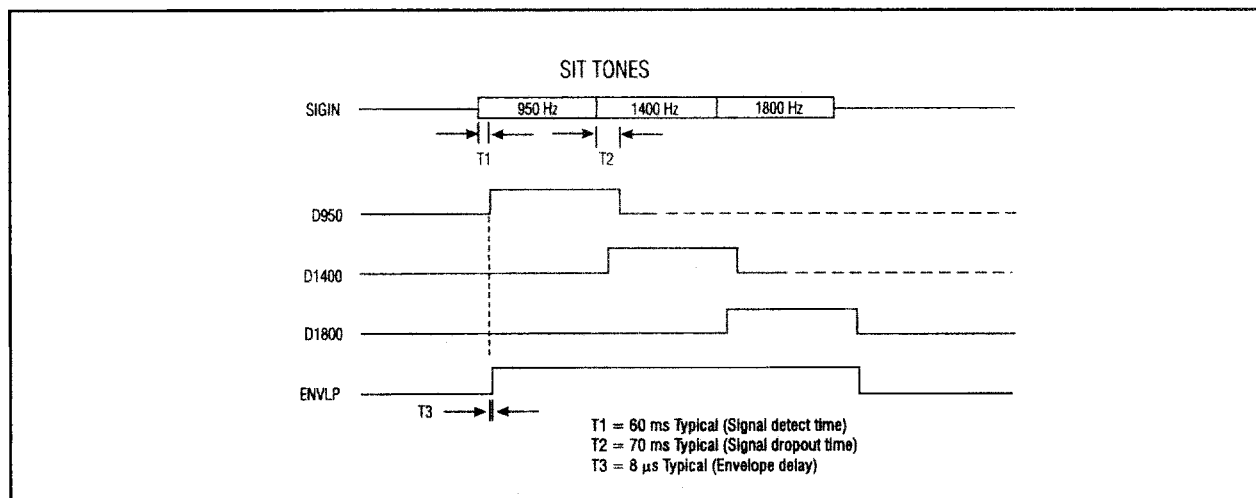

Figure 4 Timing Diagram

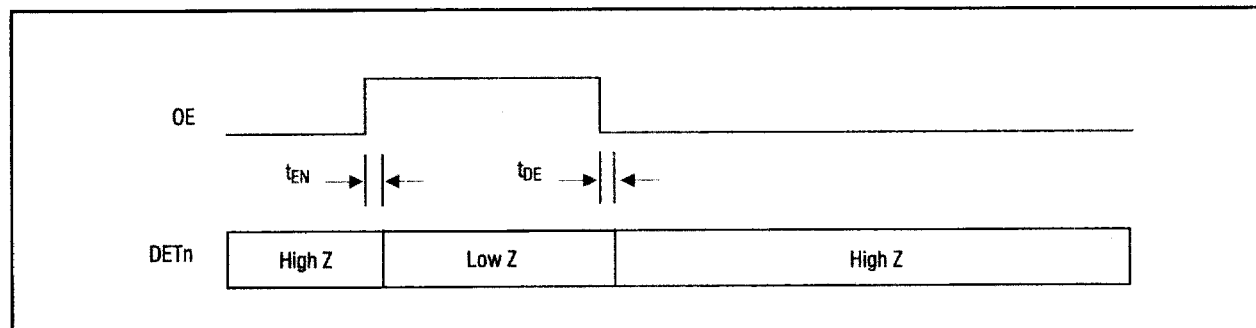
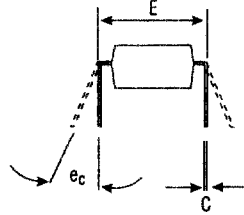
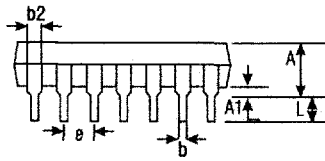
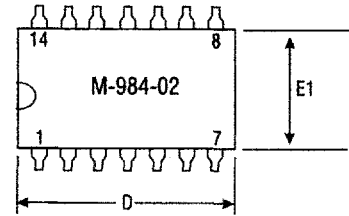

Figure 5 Tri-State Timing

**M-984-02**

Drawing not to scale.  
Does not reflect actual part marking.

**14-Pin DIP**



	Tolerances (inches)			Metric Approximation (mm)		
	Min	Nom	Max	Min	Nom	Max
A			.210			5.33
A1	.015			.38		
b	.014	.018	.022	.36	.46	.56
b2	.045	.060	.070	1.1	1.5	1.8
C	.008	.010	.014	.20	.25	.36
D	.735	.750	.775	18.7	19.1	19.7
E	.300	.310	.325	7.6	7.9	8.3
E1	.240	.250	.280	6.1	6.4	7.1
e	100 BSC			2.54 BSC		
ec	0°	15°	15°	0°		15°
L	.115	.130	.150	2.9	3.3	4.1

**16-Pin SOIC**

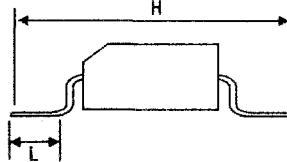
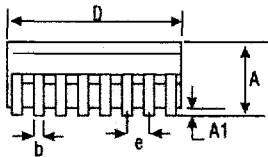
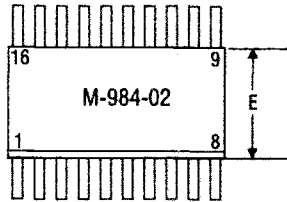

	Tolerances (mm)		SAE approximation (inches)	
	Min	Max	Min	Max
A	2.35	2.65	.0926	1.043
A1	.10	.30	.0040	.0118
b	.33	.51	.013	.020
D	10.10	10.50	.3977	4.133
E	7.4	7.6	.2914	2.992
e	1.27 BSC		.050 BSC	
H	10.00	10.65	.394	.419
L	.40	1.27	.016	.050

**Figure 5 Package Dimensions**

**Ordering Information**

- M-984-02P            14-pin plastic DIP
- M-984-02S            16-pin plastic, SOIC
- M-984-02T            16-pin SOIC, Tape and Reel