

A-8402 Single Supply Voltage-to-Frequency-to-Voltage Converter

DESCRIPTION

The A-8402 is a low-cost monolithic voltage-to-frequency converter that provides linear conversion of analog signals to a digital pulse train whose repetition rate is proportional to the analog signal.

Key features of the A-8402 V/F/V are its single power supply operation and the ability to be scaled over a 0 to +18V/0 to 100kHz range and virtually achieve 11 bit accuracy with a minimum number of components.

A maximum nonlinearity of $\pm 0.05\%$ ($\pm 0.1\%$) for the A-8402 with a 10kHz (100kHz) full scale output and the versatility offered by the A-8402 makes this low cost V/F/V converter an ideal choice for very accurate data encoding and decoding. When linked to a frequency-to-voltage converter such as the A-8402, connected for F/V operation, an accurate two-wire data link may be formed with the V/F as the transmitter and the F/V as the receiver. The A-8402 may also be linked to a binary counter which can perform approximately 390 8-bit digital conversions per second. The A-8402 is especially suited for applications in data transmission, magnetic tape recording, servo loops and isolating analog from digital.

FEATURES

- Single Supply — +5 to +18 V_{CC}
- 0 to +V_{CC} Conversion to:
100 kHz, $\pm 0.1\%$ Accuracy
10 kHz, $\pm 0.05\%$ Accuracy
- LED Drive Capability
- DTL/TTL and CMOS Compatible Output/Input
- Small Size — 14 Pin DIP
- Low Cost

APPLICATIONS

- Remote Control or Monitoring
- 2-Wire Digital Transmission
- Telemetry
- Isolation
- Servo Loops
- Synchronous Speed Control
- Magnetic Tape Recording

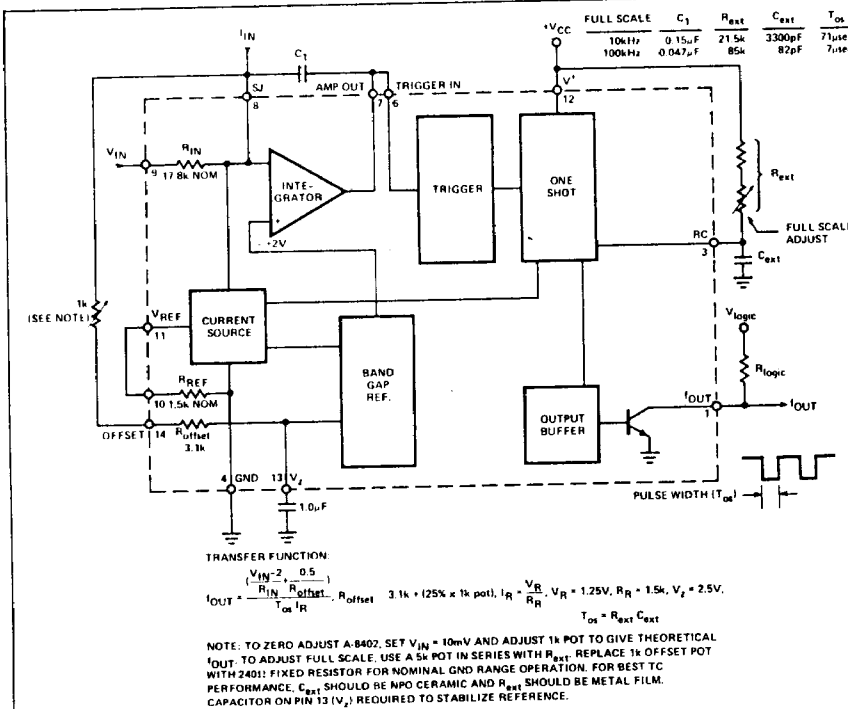
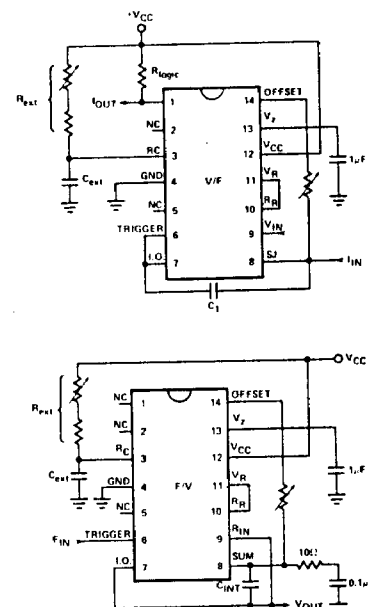

Figure 1. A-8402 Hook-Up — V/F Mode

PIN CONNECTION



SPECIFICATIONS

(Typical @ +25°C and +12V Supplies, Unless Otherwise Noted)

Parameter	A-8402	
TRANSFER CHARACTERISTIC	$f_{out} = \frac{V_{IN}}{10} F_{full\ scale}$	
ACCURACY ¹	5 decades	
Resolution		
Linearity, FS	±0.05% max	
10kHz bandwidth	±0.1% max	
100kHz bandwidth	inherent	
Monotonic	±15%	
Scale Factor ²	Note 2	
Offset	Note 2	
STABILITY ^{1,8}		
Scale Factor		
vs. Temperature	typ	±50ppm/°C
@ 10kHz	max	±100ppm/°C
vs. Power Supply	±200ppm/%	
vs. Time/day	±100ppm	
vs. Time/month	±200ppm	
Offset		
vs. Temperature	typ	±80ppm/°C
	max	±100ppm/°C
vs. Power Supply	±100μV/%	
vs. Time/day	±15ppm	
vs. Time/month	±30ppm	
Bandgap Reference (V _Z =2.5V nom.)	±25ppm/°C	
RESPONSE – V/F Mode		
Settling Time, to 0.01%, FS Step	2 cycles max ³	
Overload Recovery	10ms	
RESPONSE – F/V Mode	Depends on C _{INT} ·R _{IN} time constant	
INPUT (V/F)/OUTPUT (F/V)		
Voltage Range ^{4,5}	0 to +10V	
Current Range	0 to +1mA	
Configuration	Single-ended	
Impedance (voltage input)	17.8kΩ nominal	
Overvoltage Protection (V _{IN})	+V _{CC}	
OUTPUT (V/F)/INPUT (F/V)		
Frequency Range ⁴	0 to 500kHz	
Overrange	Depends on external RC time constant	
Waveform ⁶	Compatible with DTL, TTL & CMOS	
Fan Out ⁷ – V _{sat} =0.4V	5 TTL Loads	
– V _{sat} =1V	20mA	
Short Circuit Protection	Indefinite to GND	
TEMPERATURE		
Rated	0 to +70°C	
Operating	–25 to +85°C	
Storage	–55 to +125°C	
POWER SUPPLY – V _{CC}		
Voltage – rated	+12V	
– operate	+5 to +18V	
Current	+20mA @ +12V	

NOTES: 1. Applies to V/F & F/V modes. 2. Adjustable to zero error. 3. Of final frequency. 4. Adjustable to other full scale input/output levels. 5. F/V mode—min. V_{OUT}=0.4V. 6. Output level determined by external pull-up resistor. 7. One TTL load unit is –1.6mA at LO (+0.4V) and +40μA at HI (+2.4V). 8. Warm-up time = 5 min.

OPERATION

V/F Mode

An improved form of the charge-balancing technique is used in the A-8402. The analog input forces a current to flow through R_{IN} into C₁ causing the output of the integrator to move in a negative direction (see Figure 1). At a nominal .7 volt level, the comparator circuit triggers the timing reference network to turn the controlled current source on so that it discharges C₁. As the capacitor discharges, the output of the integrator moves in a positive direction. When the timing reference has finished discharging the capacitor, the output of the integrator is positive and ready to start the process again for the next cycle. For current inputs into the summing junction (Pin 8), it is recommended for good temperature stability that an external R_{REF} be used between Pin 11 and ground. It is also recommended that the internal R_{offset}, R_{REF} and R_{IN} be used together for good TC performance. T_{OS} influences frequency stability; therefore low TC components should be used.

F/V Mode

As a frequency-to-voltage converter, the A-8402 accepts negative-going TTL-Level pulses into the trigger circuit which starts the one-shot cycle (period=T_{OS}=R_{ext}C_{ext}). (See Figure 2).

The current source forces current out of the summing junction for the one-shot period. The amplifier acts as a current-to-voltage integrator providing a voltage output proportional to the average current (also proportional to the input frequency). Output ripple is controlled by the integrating capacitor (C_{INT} – see Figure 2). A low pass filter is recommended on Pin 8. Pin 13 may be used for external referencing (maximum current drain <350μA).

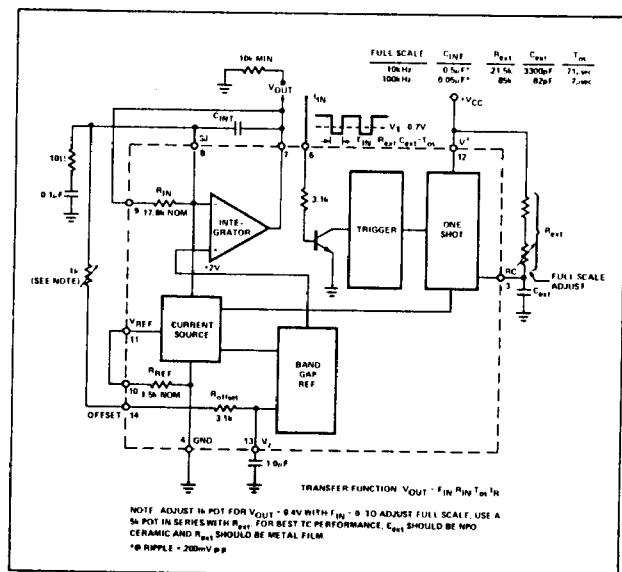

Figure 2. A-8402 Hook-Up – F/V Mode

intech
MICROCIRCUITS DIVISION

CUSTOM SERVICE IS OUR STANDARD

2270 MARTIN AVENUE, SANTA CLARA, CALIFORNIA 95050-2781
TELEPHONE (408) 988-4930 TWX 920-338-2213

008946