



## Features

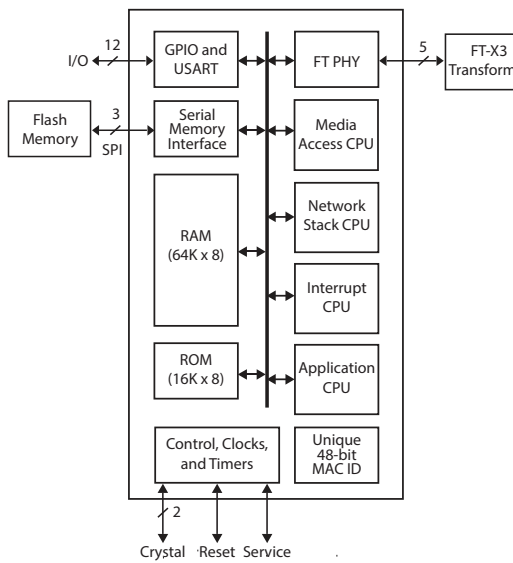

Figure 1: FT 6010 Smart Transceiver

- Built-in LON/IP Enhanced Mode, BACnet/IP, and BACnet MS/TP stacks provide easy-to-use protocol stacks for implementing IoT devices
- Built-in free topology (FT) transceiver provides a cost-effective ISO-standard twisted-pair networking solution that addresses many of the limitations and complexities of RS-485 with support for polarity-insensitive free topology star, daisy chain, bus, loop, or mixed topology wiring and very high noise immunity
- Integrated quad core processor supports applications up to 256KB
- Supports up to 254 network variables (NVs), 127 aliases, and 254 address table entries
- Up to 80MHz system clock
- On-chip 64KB RAM and 16KB ROM
- 3.3V operation
- User-programmable interrupts, hardware USART, and 12 GPIO pins with 35 configurable I/O drivers
- Compatible with low-cost surface mount FT-X3 Communications Transformer
- Low-cost and royalty-free IzoT® FT 6000 EVK available for rapid application development and testing
- Free and royalty-free IzoT SDKs available for simple integration with other processors
- Supports a rich set of LONMARK® and IoT standard profiles and data types to reduce application development time
- Flash file system for data logging and other applications requiring persistent storage
- Unique 48-bit IEEE MAC ID
- 7mm x 7mm 48-pin QFN package
- -40°C to 85°C industrial temperature range

## Build Free Topology Wired Devices for the Industrial IoT

The FT 6010 Smart Transceiver is a system-on-chip for implementing IoT devices for the Industrial Internet of (IIoT) that communicate using a single polarity-insensitive twisted pair cable. Up to 64 devices can be attached to the cable, with the cable installed as a star, bus, daisy-chain, loop, or combination topology (see Figure 2). This free topology capability provides an easier-to-install alternative to RS-485 communication. Installers don't have to follow a strict set of wiring rules imposed by other networking technologies. Instead, they can install wiring in the fastest and most cost-effective manner, thereby saving time and money. FT wiring also simplifies network expansion by eliminating restrictions on wire routing, splicing, and device placement.

The FT 6010 extends all the benefits of FT wiring to IP devices, allowing an efficient multi-drop IP capability where multiple IP devices can be very simply connected in any topology without the need for switches or hubs.

The FT 6010 Smart Transceiver integrates a high-performance Neuron® quad core processor with an FT twisted-pair transceiver. Combined with the proven FT-X3 Communications Transformer and inexpensive flash memory, the FT 6010 Smart Transceivers provide a very flexible, low-cost, feature-enhanced LON/IP Enhanced Mode, BACnet MS/TP, and BACnet/IP solution all within the same device with a single application.

A rich set of LONMARK and IoT standard profiles and data types is included that you can use to further reduce application development time.

Figure 3 summarizes the benefits of FT communication over RS-485.

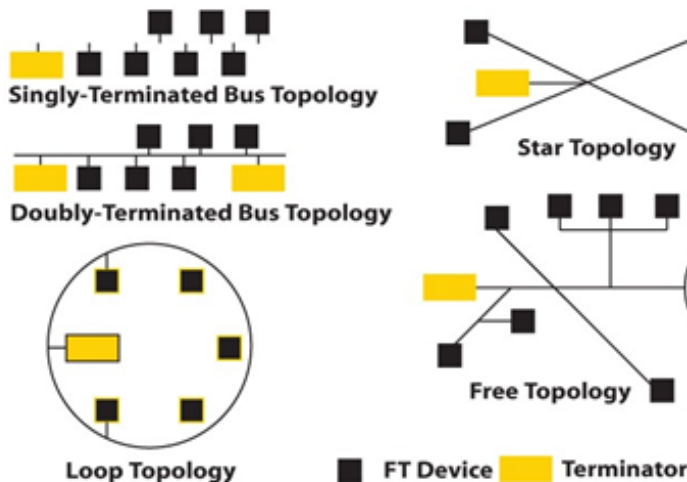

Figure 2: FT Free Topology Network Configurations

FT (ISO/IEC 14908-2)		RS-485(EIA-485)
<ul style="list-style-type: none"> <li>Minimal installer expertise needed</li> <li>Only 2 connections per device</li> <li>Polarity insensitive</li> </ul>	<b>EASE OF INSTALLATION</b>	<ul style="list-style-type: none"> <li>Requires skilled technician</li> <li>Typically 3 connections per device (with isolated ground)</li> <li>Must maintain polarity</li> </ul>
<ul style="list-style-type: none"> <li>Choice of unshielded or shielded twisted pair, or low-cost CAT 5 cable</li> <li>Lower installed cost with small premium on transceiver cost</li> </ul>	<b>COST OF INSTALLATION</b>	<ul style="list-style-type: none"> <li>Requires costly shielded cable</li> <li>Low transceiver cost</li> <li>Locating installation faults offsets savings on equipment</li> </ul>
<ul style="list-style-type: none"> <li>Individual faults do not degrade network performance</li> <li>Electrically isolated</li> <li>Conducted RF immunity; meets EN 61000-4-6 Level 3 standard</li> </ul>	<b>PERFORMANCE &amp; RELIABILITY</b>	<ul style="list-style-type: none"> <li>Vulnerable to total network loss upon fault</li> <li>Susceptible to RF interference; varies per device</li> </ul>
<ul style="list-style-type: none"> <li>Up to 64 network devices</li> <li>Supports mixed topologies</li> </ul>	<b>FLEXIBILITY</b>	<ul style="list-style-type: none"> <li>Up to 32 network devices</li> <li>Options to extend to 256</li> <li>Requires linear bus topology</li> </ul>
<ul style="list-style-type: none"> <li>Easy to expand</li> </ul>	<b>SCALABILITY</b>	<ul style="list-style-type: none"> <li>Expansion requires extensive and expensive rewiring</li> </ul>
<ul style="list-style-type: none"> <li>Ease of fault detection minimizes repair time and system down time</li> </ul>	<b>MAINTENANCE &amp; TROUBLESHOOTING</b>	<ul style="list-style-type: none"> <li>Difficulty in locating network faults extends repair time and increases down time</li> </ul>

Figure 3: FT vs RS-485 Comparison

## Multi-Protocol Operation

The FT 6010 simultaneously supports up to three different communication protocols, as shown in Figure 4, allowing device makers unprecedented flexibility in creating control devices for a wide variety of applications using one application.

For LON/IP Enhanced Mode communication, the FT 6010 implements layers 4 through 7 of the LON stack with enhanced transaction ID range, running on top of layers 2 and 3 of a UDP/IP stack.

This allows the implementation of devices that support native IP addressing at the device level with support for more complex network topologies due to the increased transaction ID range.

For BACnet/IP communication, the FT 6010 implements a BACnet/IP standard stack running on top of layers 2 and 3 of a UDP/IP stack. This enables BACnet/IP-compliant applications to run on the FT channel, pushing BACnet/IP all the way down to the simplest of devices, while leveraging the ease-of-installation provided by LON commissioning tools. Devices thus provisioned are fully compatible and discoverable using industry standard, BTL certified, BACnet management clients.

For BACnet MS/TP communication, the FT 6010 implements a BACnet MS/TP stack that uses one of the FT 6010 USARTS to communicate with an external RS-485 transceiver using the BACnet MS/TP protocol. This enables BACnet MS/TP-compliant applications to be implemented in parallel with LON/IP Enhanced Mode and BACnet/IP applications running on the FT 6010.

For other IP applications, the FT 6010 implements a UDP/IP stack that an application can use to create any type of IP interface that communicates with the easy-to-use and easy-to-install FT channel.

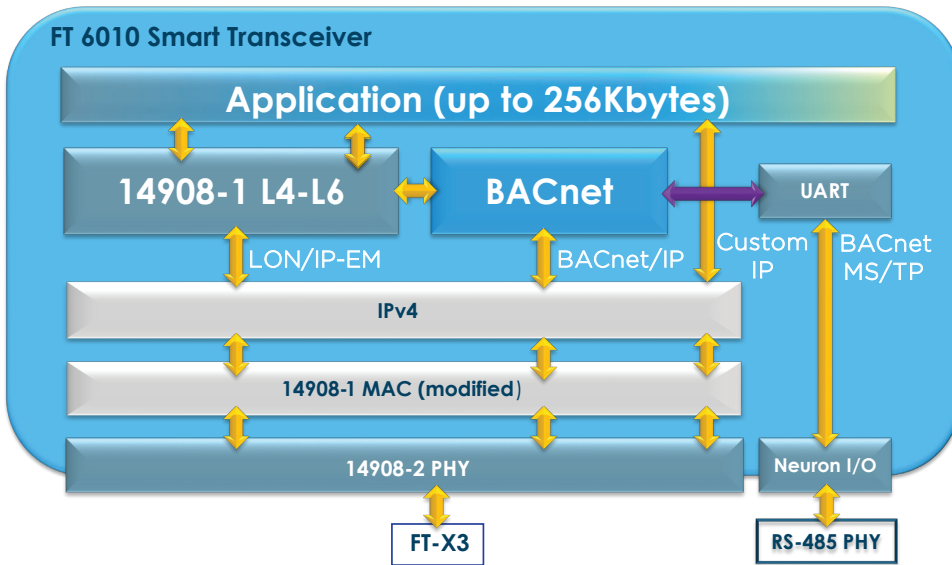

Figure 4: FT 6010 Firmware Protocol Stacks

## Enhanced Performance

### Neuron Core Speed

The internal system clock for the FT 6010 Smart Transceiver can be configured to run from 5MHz to 80MHz. The required external crystal provides a 10MHz clock frequency, and an internal PLL boosts the frequency to a maximum of 80MHz as the internal system clock speed.

The Neuron core inside the FT 6050 Smart Transceiver includes a built-in hardware multiplier and divider to increase the performance of arithmetic operations.

### Interrupts

The FT 6010 Smart Transceiver lets developers define application interrupts to handle asynchronous events triggered by selected state changes on any of the 12 GPIO pins, by on-chip hardware timer-counter units, or by an on-chip high-performance hardware system timer.

### MAC Layer Enhancements

The FT 6010 has an enhanced MAC layer that allows frame sizes up to 1280 bytes. This allows large IP frames to be carried over the FT channel without fragmenting the packet to provide better bandwidth utilization of the FT channel.

The dedicated processor cores for the MAC and network protocol support allows the application to have the same performance independent of the network traffic. Traditional uni-processor designs running popular transceivers such as RS-485 must be interrupted repeatedly to receive every packet on the network, even when the packet turns out to not be

addressed to the device. This increases the demands on the application processor and makes the amount of processing available to the application difficult to predict as it becomes a function of the network load.

### JTAG Interface

The FT 6010 Smart Transceiver provides an interface for the Institute of Electrical and Electronics Engineers (IEEE) Standard Test Access Port and Boundary-Scan Architecture (IEEE 1149.1-1990) of the Joint Test Action Group (JTAG) to allow an FT 6010 chip to be included in the boundary-scan chain for device production tests.

### GPIO

The FT 6010 Smart Transceiver provides 12 bidirectional GPIO pins that are 5V-tolerant and can be configured to operate in one or more of 35 predefined standard input/output modes. The chip also has two 16-bit timer/counters and a hardware USART that reduce the need for external logic and software development.

### Memory Architecture

The FT 6010 Smart Transceiver requires an inexpensive external flash memory for non-volatile application and data storage, and for Neuron firmware upgrades. It has 16KB of ROM and 64KB (44KB user-accessible) of RAM on the chip. Each chip, contains a unique identifier (IEEE MAC ID) in an on-chip, non-volatile, read-only memory. Typical external flash memory configuration is 1MB of which 256KB is available for application code.

The application code and configuration data are stored in the external non-volatile

memory (NVM) and copied into the internal RAM during device reset; the instructions then execute from internal RAM. Writes to NVM are shadowed in the internal RAM and pushed out to external NVM by the Neuron firmware.

The FT 6010 Smart Transceiver supports serial peripheral interface (SPI) for accessing off-chip, non-volatile memory.

The FT 6010 Smart Transceiver supports a variety of flash devices from different manufacturers. Echelon has qualified the following SPI flash memory devices for use with the FT 6010 Smart Transceiver:

- Winbond W25X40CL 4-Mbit SPI Serial Flash Memory.

## Noise Immunity

A device based on the FT 6010 Smart Transceiver is composed of two components: the FT 6010 Smart Transceiver and an external communications transformer such as the FT-X3 communications transformer. The transformer enables operation in the presence of high frequency common-mode noise on unshielded twisted-pair networks. Properly designed devices can meet the rigorous Level 3 requirements of EN 61000-4-6 without the need for a network isolation choke. The transformer also offers outstanding immunity from magnetic noise, eliminating the need for protective magnetic shields in most applications.

## 6K Chip Design Information

### 6K IC Pin Configuration

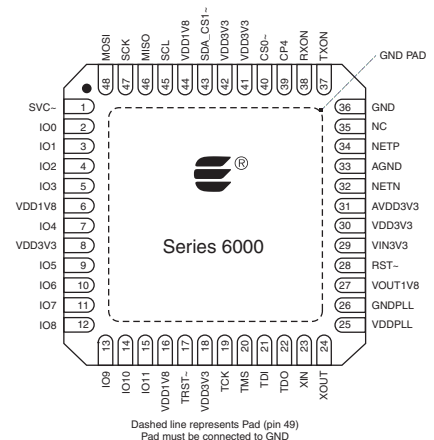

Figure 5: 6K IC Pin-out

## 6K Pad Layout

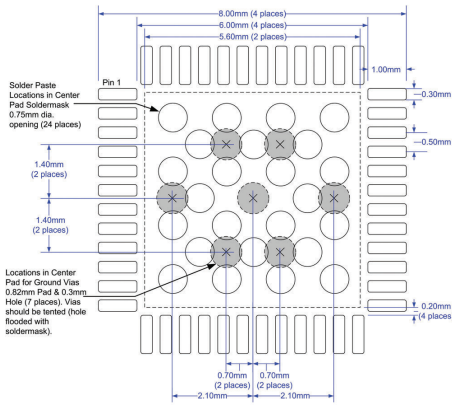
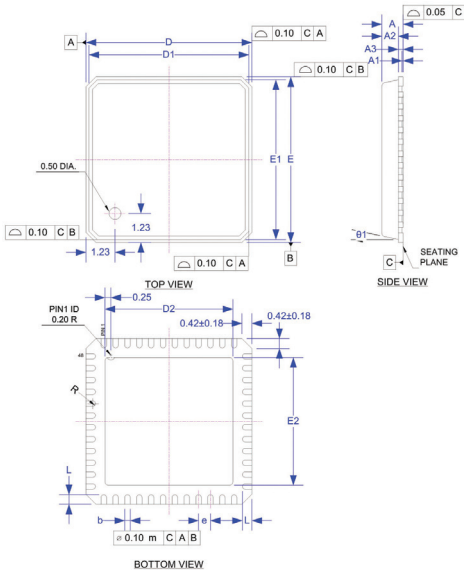

Figure 6: Recommended 6K Pad Layout

## 6K IC Mechanical Specifications



SYMBOL	MILLIMETER			INCH		
	MIN.	NOM.	MAX.	MIN.	NOM.	MAX.
A	---	---	0.90	---	---	0.035
A1	0.00	0.01	0.05	0.00	0.0004	0.002
A2	---	0.65	0.70	---	0.026	0.028
A3	0.20 REF.			0.008 REF.		
b	0.18	0.23	0.30	0.007	0.009	0.012
D	7.00 bsc			0.276 bsc		
D1	6.75 bsc			0.266 bsc		
D2	5.20	5.40	5.60	0.205	0.213	0.220
E	7.00 bsc			0.276 bsc		
E1	6.75 bsc			0.266 bsc		
E2	5.20	5.40	5.60	0.205	0.213	0.220
L	0.30	0.40	0.50	0.012	0.016	0.020
e	0.50 bsc			0.020 bsc		
θ1	0°	---	12°	0°	---	12°
R	0.09	---	---	0.004	---	---
TOLERANCES OF FORM AND POSITION						
aaa	0.10			0.004		
bbb	0.10			0.004		
ccc	0.05			0.002		

Figure 7: 6K IC Dimensions

## Notes

1. All dimensions are in millimeters.
2. Dimensions and tolerances conform to ASME Y14.5M.-1994.
3. Package warpage max. 0.08 mm.
4. Package corners unless otherwise specified are  $R0.175 \pm 0.025$  mm.

## FT-X3 Design Information

### FT-X3 Pin Configuration

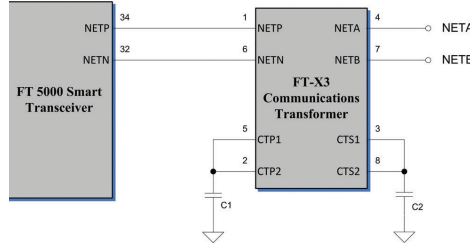

Figure 8: FT-X3 Pin-out

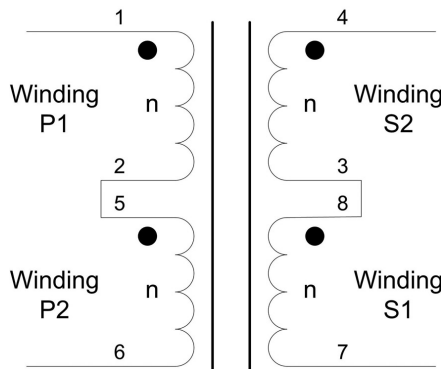

Figure 9: FT-X3 Transformer Pin Assignments

There is no marking for Pin 1 on the FT-X3 because it is rotationally symmetric..

## FT-X3 Pad Layout

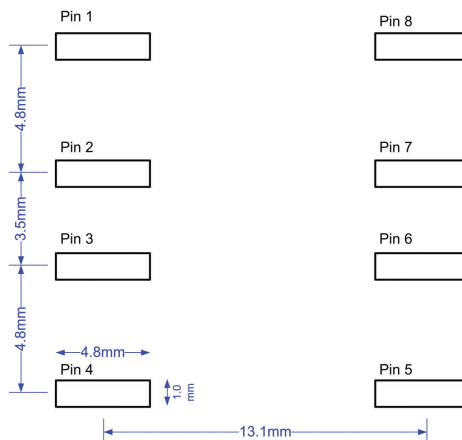

Figure 10: FT-X3 Pad Layout

Add vias to the ends of each pin pad connection (just outside of the SMT

pad rectangles) to provide additional mechanical support for the transformer

## FT-X3 Mechanical Specifications

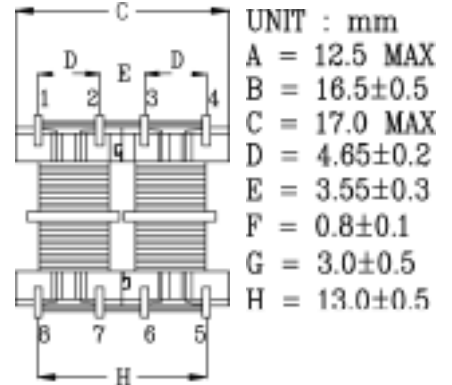
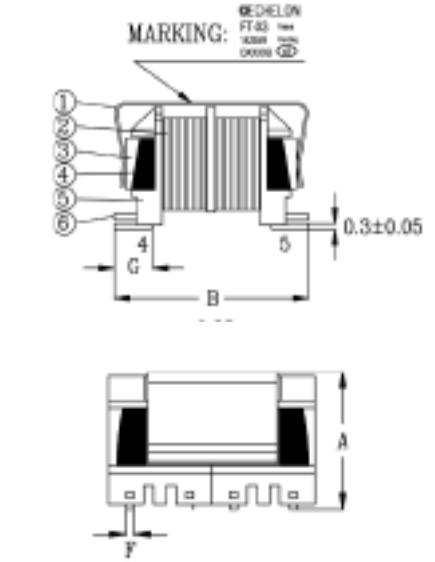

Figure 11: FT-X3 Dimensions

## Tape and Reel

### 6K Tape and Reel

6K ICs are uniformly loaded in the carrier tape such that pin one is oriented in quadrant 1 toward the side of the tape having round sprocket holes. Figure 11 illustrates the pin-one location.

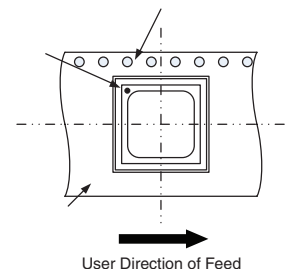

Figure 12: 6K Tape and Reel Orientation

Figure 13 illustrates the outline dimensions of the carrier tape.

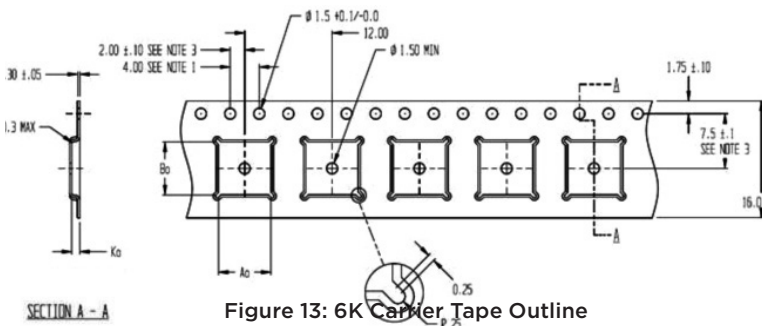

Figure 13: 6K Carrier Tape Outline

$Ko = 1.10$

Notes

1. All dimensions are in millimeters.
2. Tolerances unless noted:  $1PL + 0.2$ ;  $2PL + 0.1$
3. 10 Sprocket hole pitch cumulative tolerance  $+0.2$
4. Camber in compliance with EIA 481.
5. Pocket position relative to sprocket hole measured as true position of pocket, not pocket hole.

For more information, refer to EIA-481-B, *Taping of Surface Mount Components for Automatic Placement*.

Figure 14 illustrates the 6K 7" reel and hub dimensions.

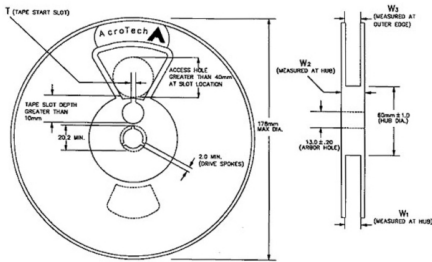

TAPE SIZE	T	W <sub>1</sub>	W <sub>2</sub>	W <sub>s</sub>
8mm	4.0 ± 0.25	+1.0 8.4-0.0	14.4 MAX.	7.8 MIN. 10.9 MAX.
12mm	5.0 ± 0.50	+2.0 12.4-0.0	18.4 MAX.	11.8 MIN. 15.4 MAX.
15mm	7.0 ± 0.50	+2.0 16.4-0.0	22.4 MAX.	15.8 MIN. 19.4 MAX.
24mm	11.0 ± 0.50	+2.0 24.4-0.0	30.4 MAX.	23.8 MIN. 27.4 MAX.
32mm	11.0 ± 0.50	+2.0 32.4-0.0	38.4 MAX.	31.8 MIN. 35.4 MAX.
44mm	11.0 ± 0.50	+2.0 44.4-0.0	50.4 MAX.	43.8 MIN. 47.4 MAX.

Figure 14: 6K 7" Reel and Hub

FT-X3 Tape and Reel

Figure 15 illustrates the placement of each device on the carrier tape.

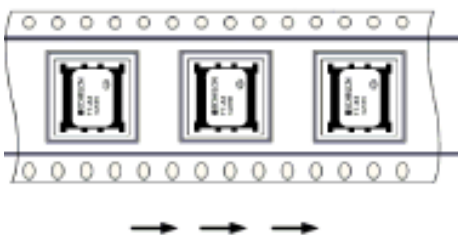
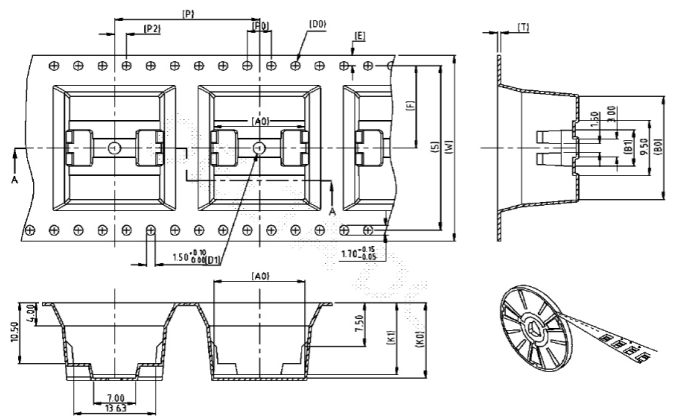

Figure 15: FT-X3 Carrier Tape Placement



SECTION:A-A

W	32.00±0.30	P	24.00±0.10	AO	15.10±0.10	BO	17.80±0.15
S	28.40±0.10	PO	4.00±0.10			B1	6.30±0.10
E	1.75±0.10	P2	2.00±0.10				
F	14.20±0.10	DO	1.50±0.10	KO	13.00±0.10		
T	0.50±0.04	D1	2.00 MIN	K1	12.40±0.10		

COLOR : BK/ANT

Figure 17:

FT-X3 Carrier Tape Packing

6. Packing length per 22" reel: 10.2 meters
7. Packing length per 13" reel: 3.4 meters
8. Component load per 13" reel: 100 PCS
9. Compression strength: 1.5 kgf min.
10. Environment-related substance must meet DELTA's general spec no. 10000-0162

Application Development

A typical FT 6010 Smart Transceiver-based device requires a power source, crystal, external memory, and an I/O interface to the device being controlled (see Figure 18 for a typical FT 6010 Smart Transceiver-based device).

Echelon provides all of the building blocks required to successfully design and field cost-effective, robust products based on the FT 6010 Smart Transceiver. Echelon's end-to-end solutions include a comprehensive set of development tools, network interfaces, routers, and network tools. In addition, pre-production design review services, training, and worldwide technical support (including onsite support) are available through Echelon's Support technical assistance program.

Figure 16 shows the reel and hub dimensions.

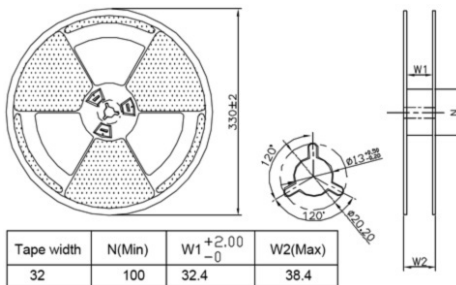

Figure 16: FT-X3 Reel and Hub

Notes

1. All dimensions are in millimeters.
2. Tolerances unless noted:  $1PL +$ ;  $2PL + 0.2$ ;  $3PL + 0.1$ ;  $ANG + 0.5$ ;  $FRACT +$

Figure 17 illustrates the FT-X3 carrier tape dimensiona.

Notes

1. Material: black conductive polystyrene PS
2. Inspect per EIA-481-3 standard.
3. Tape thickness:  $0.5 \pm 0.05$  mm
4. 10 Sprocket hole pitch cumulative tolerance  $\pm 0.20$
5. Carrier chamber is within 1 mm in 100 mm

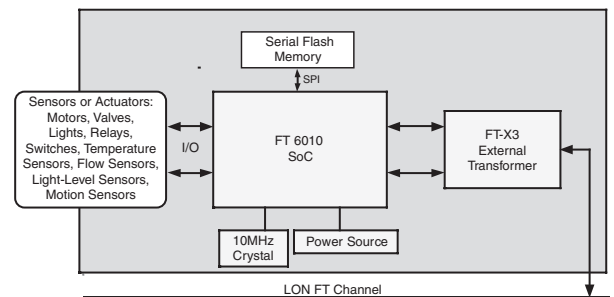

Figure 18: Typical FT 6010-based Device

The following development tools are available for developing applications for the FT 6010 Smart Transceiver:

- **IzoT FT 6000 EVK** — a complete hardware and software platform for creating or evaluating LON/IP Enhanced Mode, BACnet/IP, and BACnet MS/TP devices based on the FT 6010 Smart Transceiver. Using the FT 6000 EVK, developers can create applications that run on the FT 6010 Smart Transceiver using the highly productive Neuron C programming language.
- **IzoT SDK Premium Edition** — a software development kit that enables developers to build communicating devices using any processor that runs Linux for the application and Layers 3 through 7 of the LonTalk/IP and LON protocol stacks. The IzoT SDK Premium Edition includes royalty-free firmware for the FT 6010 Smart Transceiver that enables the FT 6010 to be used as a PHY chip to interface to an FT channel.
- **IzoT ShortStack SDK** — a free software development kit that enables developers to build communicating devices using any processor that can run the application plus a tiny IzoT ShortStack driver. The IzoT ShortStack SDK includes royalty-free firmware for the FT 6010 Smart Transceiver that enables the FT 6010 to be used as a Layer 2 to 6 LON/IP Enhanced Mode protocol processor with integrated PHY interface to an FT channel.

## Specifications

### Data Communications Type

Differential Manchester encoding

### Network Polarity

Polarity insensitive

### Isolation between Network and FT 6050 IC

0-60Hz, 60 seconds: 1000Vrms; 0-60Hz, continuous: 277Vrms

### EMI

Compliant with FCC Part 15 Subpart B and EN55022 Level B

### ESD

Compliant with EN 61000-4-2, Level 4

### Radiated Electromagnetic Susceptibility

Compliant with EN 61000-4-3, Level 3

### Fast Transient/Burst Immunity

Compliant with EN 61000-4-4, Level 4

### Surge Immunity

Compliant with EN 61000-4-5, Level 3

### Conducted RF Immunity

Compliant with EN 61000-4-6, Level 3

### Transmission Speed

78 kilobits per second

### Number of Transceivers per Segment

Up to 64

### Network Wiring

24 to 16AWG twisted pair; see *Series 6000 Chip Data Book* or *Junction Box and Wiring Guidelines* engineering bulletin for qualified cable types

### Network Length in Free Topology

500m (1640 feet) maximum total wire with no repeaters.  
500m (1640 feet) maximum device-to-device distance

### Network Length in Doubly-terminated Bus Topology

2700m (8,850 feet) with no repeaters

### Maximum Stub Length in Doubly-terminated Bus Topology

3m (9.8 feet)

### Network Termination

One terminator in free topology; two terminators in bus topology (more details in *Series 6000 Chip Data Book*).

### Power-down Network Protection

High impedance when unpowered.

### Operating Temperature

-40 to 85°C

### Operating Humidity

25-90% RH @50°C, non-condensing (FT-X3 Communications Transformer)

### Non-operating Humidity

95% RH @ 50°C, non-condensing (FT-X3 Communications Transformer)

### Vibration

1.5g peak-to-peak, 8Hz-2kHz (FT-X3 Communications Transformer)

### Mechanical Shock

100g (peak) (FT-X3 Communications Transformer)

### Reflow Soldering Temperature Profile

Refer to *Joint Industry Standard document IPC/JEDEC J-STD-020D.1* (March 2008)

### Peak Reflow Soldering Temperature

260°C (FT 6050 Smart Transceiver).  
245°C (FT-X3 Communications Transformer)

### Co-planarity

0.12 mm (FT-X3 Communications Transformer)

### Mass

6g (FT-X3 Communications Transformer)

## Ordering Information

### Components

- 14410R-500 FT 6010 Smart Transceiver
- 14255R-100 FT-X3 Communications Transformer

### Development Tools

- 10070R-43-54 IzoT FT 6000 EVK
- 23360-10 IzoT SDK Premium Edition
- 23400-FV IzoT ShortStack SDK