

DRAWING NUMBER:	09-9228-1-XXXX
PRODUCT GROUP:	PANEL JACKS AND TERMINALS
SUB-GROUP:	PANEL JACKS AND TERMINALS - THREAD MOUNT
DESCRIPTION:	PANEL JACK - METAL THREAD

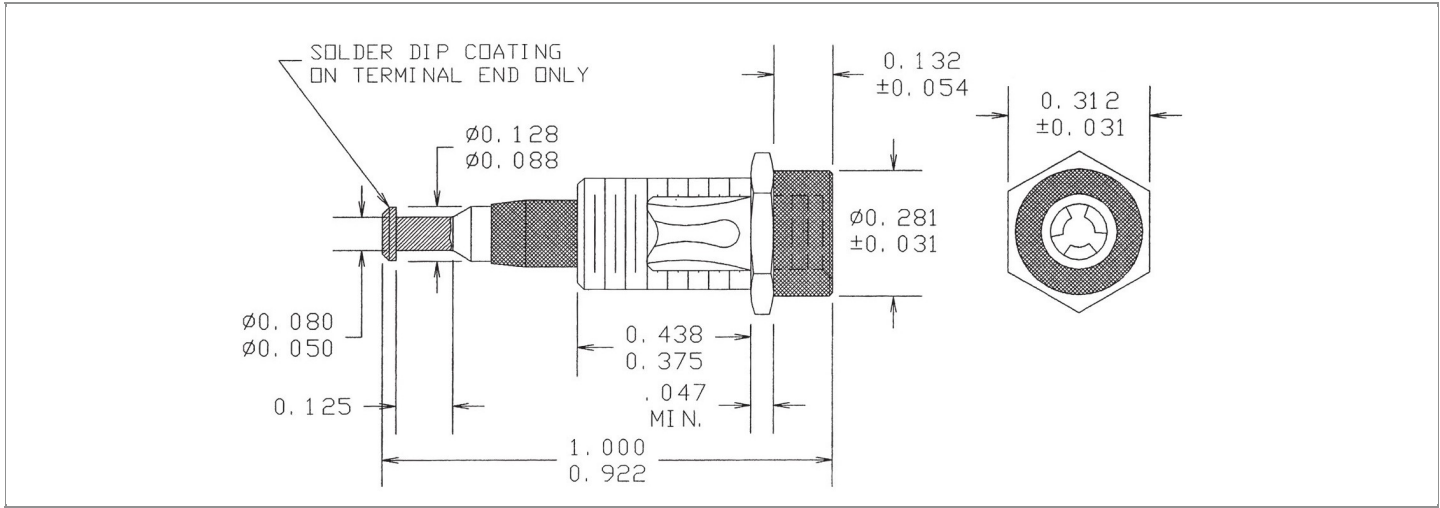

ACCEPTS PIN / PLUG / JACK SIZE	MIN. HOLE DEPTH	MOUNTING ORIENTATION	BOARD / PANEL MOUNTING METHOD
0.080" ± 0.001	0.420"	VERTICAL	THREAD MOUNT (1/4-32 NUT)
MOUNTING HOLE SIZE	BOARD / PANEL THICKNESS	FEED THRU COMBINATION	OVERALL LENGTH
0.257" ± 0.002	UP TO 3/16"	JACK/TURRET	0.922"

PART NO. STRUCTURE:

09-9228	-	1	-	XX	XX
PART SERIES		DIMENSION		FINISH	INSULATION COLOR

MATERIAL OPTIONS:

09-9228-1-XXXX

COMPONENT	MATERIAL	MATERIAL AND SPECIFICATION
BODY	BRASS	BRASS PER ASTM B16, ALLOY C36000, 1/2 HARD
SPRING (CAGE)	BERYLLIUM COPPER	BERYLLIUM COPPER PER ASTM B194, ALLOY C17200
INSULATION*	NYLON	NYLON PER ASTM D4066
BASE/METAL SLEEVE	BRASS	BRASS PER ASTM B16, ALLOY C36000, 1/2 HARD
NUT	BRASS	BRASS PER ASTM B16, ALLOY C36000, 1/2 HARD
WASHER	PHOSPHOR BRONZE	PHOSPHOR BRONZE PER ASTM B139/B103, ALLOY C51000
LUG	N/A	N/A

*For Insulation color, please see INSULATION COLOR OPTIONS on Page 2

FINISH - PLATING OPTIONS:

09-9228-1-XXXX

FINISH CODE	COMPONENT	FINISH	FINISH AND SPECIFICATION
03	BODY	GOLD WITH SOLDER COATED TIP	0.00010"MIN. GOLD PER ASTM B488, TYPE II, CODE C OVER 0.000100"MIN. NICKEL PER SAE-AMS-QQ-N-290, CLASS 2. TIP WITH SOLDER COATING
	SPRING (CAGE)	GOLD	0.000030"MIN. GOLD PER ASTM B488, TYPE II, CODE C OVER 0.000100"MIN. NICKEL PER SAE-AMS-QQ-N-290, CLASS 2
	BASE/METAL SLEEVE	NICKEL	0.000100"MIN. NICKEL PER SAE-AMS-QQ-N-290, CLASS 2
	NUT	NICKEL	0.000100"MIN. NICKEL PER SAE-AMS-QQ-N-290, CLASS 2
	WASHER	NICKEL	0.000100"MIN. NICKEL PER SAE-AMS-QQ-N-290, CLASS 2
	LUG	N/A	N/A
035	BODY	GOLD WITH SOLDER COATED TIP	0.000020"MIN. GOLD PER ASTM B488, TYPE II, CODE C OVER 0.000030"-0.000150" NICKEL PER SAE-AMS-QQ-N-290, CLASS 2. TIP WITH SOLDER COATING
	SPRING (CAGE)	GOLD	0.000050"MIN. GOLD PER ASTM B488, TYPE II, CODE C OVER 0.000030"-0.000150" NICKEL PER SAE-AMS-QQ-N-290, CLASS 2
	BASE/METAL SLEEVE	NICKEL	0.000200"MIN. NICKEL PER SAE-AMS-QQ-N-290, CLASS 1
	NUT	NICKEL	0.000200"MIN. NICKEL PER SAE-AMS-QQ-N-290, CLASS 1
	WASHER	NICKEL	0.000200"MIN. NICKEL PER SAE-AMS-QQ-N-290, CLASS 1
	LUG	N/A	N/A

INSULATION COLOR OPTIONS:

09-9228-1-XXXX

INSULATION COLOR	BLACK	BROWN	RED	ORANGE	YELLOW	GREEN	BLUE	VIOLET	GRAY	WHITE
COLOR CODE NO.	10	11	12	13	14	15	16	17	18	19

TOLERANCES:*

DECIMAL	FRACTIONAL	ANGULAR	DRAWING ORIGINATION DATE	LAST MODIFICATION DATE
± 0.010	± 1/64	± 5 °	12/26/1997	1/1/2017

*All dimensions are in inches.

RoHS COMPLIANCE:

09-9228-1-03XX

PART NUMBER	RoHS COMPLIANT
09-9228-1-0310	NO
09-9228-1-0311	NO
09-9228-1-0312	NO
09-9228-1-0313	NO
09-9228-1-0314	NO
09-9228-1-0315	NO
09-9228-1-0316	NO
09-9228-1-0317	NO
09-9228-1-0318	NO
09-9228-1-0319	NO

09-9228-1-035XX

PART NUMBER	RoHS COMPLIANT
09-9228-1-03510	NO
09-9228-1-03511	NO
09-9228-1-03512	NO
09-9228-1-03513	NO
09-9228-1-03514	NO
09-9228-1-03515	NO
09-9228-1-03516	NO
09-9228-1-03517	NO
09-9228-1-03518	NO
09-9228-1-03519	NO

MILITARY REFERENCE SPECIFICATIONS:

09-9228-1-03XX

PART NUMBER	MIL SPECIFICATION	MIL PART NUMBER
09-9228-1-0310	N/A	N/A
09-9228-1-0311	N/A	N/A
09-9228-1-0312	N/A	N/A
09-9228-1-0313	N/A	N/A
09-9228-1-0314	N/A	N/A
09-9228-1-0315	N/A	N/A
09-9228-1-0316	N/A	N/A
09-9228-1-0317	N/A	N/A
09-9228-1-0318	N/A	N/A
09-9228-1-0319	N/A	N/A

09-9228-1-035XX

PART NUMBER	MIL SPECIFICATION	MIL PART NUMBER
09-9228-1-03510	MIL-DTL-39024/10	M39024/10-03
09-9228-1-03511	MIL-DTL-39024/10	M39024/10-04
09-9228-1-03512	MIL-DTL-39024/10	M39024/10-02
09-9228-1-03513	MIL-DTL-39024/10	M39024/10-06
09-9228-1-03514	MIL-DTL-39024/10	M39024/10-08
09-9228-1-03515	MIL-DTL-39024/10	M39024/10-05
09-9228-1-03516	MIL-DTL-39024/10	M39024/10-07
09-9228-1-03517	MIL-DTL-39024/10	M39024/10-10
09-9228-1-03518	MIL-DTL-39024/10	M39024/10-09
09-9228-1-03519	MIL-DTL-39024/10	M39024/10-01

NOTES:

DATASHEET NOTES

FOR PART NO. WITH FINISH "03": SOLDER DIP COATING ON TERMINAL END ONLY, NUT PART NO.: 701-7414-02, WASHER PART NO.: 701-7705-02; FOR PART NO. WITH FINISH "035": SOLDER DIP COATING ON TERMINAL END ONLY, NUT PART NO.: 701-7414-022, WASHER PART NO.: 701-7705-022.

INSTRUCTION NOTES

SUPPLIED WITH NICKEL PLATED BRASS HEX NUT (1/4-32 x 11/32" x 3/32") AND NICKEL PLATED PHOSPHOR BRONZE 1/4 INTERNAL TOOTH LOCKWASHER.