

Triacs

TCE Type	MAXIMUM RATINGS						OPERATING CHARACTERISTICS										Figure No.
	Repetitive Peak Off-State Voltage V <sub>DRM</sub> V	On-State RMS Current I <sub>T</sub> A	Peak Non-Repetitive Surge Current I <sub>TSM</sub> A	Peak Forward Gate Current I <sub>GM</sub> A	Peak Reverse Gate Voltage V <sub>GM</sub> V	On-State Voltage (either direction) V <sub>TM</sub> V	Gate Trigger Voltage V <sub>GT</sub> V	Gate Trigger Current by Quadrant				Holding Current I <sub>H</sub> dv/dt mA	Critical Rate of Rise of Off-State Voltage V/μS	Gate-Controlled Turn-on Time μS			
								I	II	III	IV						
								I <sub>GT1</sub> mA	I <sub>GT2</sub> mA	I <sub>GT3</sub> mA	I <sub>GT4</sub> mA						
SK3506	400	2.5	25			2.2	0.9	5	10	5	10	6	100	1.8	S-017		
SK3507	400	15	100			1.6	1	15	35	15	35	15	40	3	S-012		
SK3508	400	15	100			1.4	1	20	35	20	35	20	100	1.6	S-015		
SK3509	400	40	300			1.7	1.35	15	30	20	40	25	30	1.7	S-015		
SK3519	600	2.5	25			2.2	0.9	5	10	5	10	6	100	1.8	S-017		
SK3521	600	30	300			2.1	1.35	15	30	20	40	25	100	1.7	S-015		
SK3522	600	40	300			1.7	1.35	15	30	20	40	25	100	1.7	S-015		
SK3533	400	15 Max	150			1.6 Max		50 Max	50 Max	50 Max	75 Typ		300	4	S-014		
SK3583	200	2.5	25			2.2	0.9	5	10	5	10	6	100	1.8	S-017		
SK3611	200	15	100			1.6	1	15	35	15	35	15	10	1.6	S-012		
SK3631	100	10	100	2		1.3	0.9	50 Max	75 Max	50 Max	75 Max	50 Max	5	1.5	S-019		
SK3632	200	10	100	2		1.3	0.9	50 Max	75 Max	50 Max	75 Max	50 Max	5	1.5	S-019		
SK3633	400	10	100	2		1.3	0.9	50 Max	75 Max	50 Max	75 Max	50 Max	5	1.5	S-051		
SK3652	200	40	300			1.7	1.35	15	30	40	20	25	200	1.7	S-015		
SK3658	200	15	150			1.3	0.9	50 Max	75 Max	50 Max	75 Max	6	5	1.5	S-014		
SK3659	400	15	150			1.3	0.9	50 Max	75 Max	50 Max	75 Max	6	5	1.5	S-014		
SK3660	600	15	150			1.3	0.9	50 Max	75 Max	50 Max	75 Max	6	5	1.5	S-014		
SK3661	200	40	300			1.7	1.35	15	30	20	40	25	200	1.7	S-021		
SK3662	400	40	300			1.7	1.35	15	30	20	40	25	150	1.7	S-021		
SK3663	600	40	300			1.7	1.35	15	30	20	40	25	30	1.7	S-021		
SK3664	100	4	30		5	2 Max	1.4	30	0	30	0	30 Max	5	1.5	S-022		
SK3665	200	4	30		5	2 Max	1.4	30	0	30	0	30 Max	5	1.5	S-022		
SK3666	400	4	30			2 Max	1.4	30	0	30	0	30 Max	5	1.5	S-022		
SK3937	100	15	150			1.6		50 Max	50 Max	50 Max	75 Typ		300 Min	4	S-014		
SK3938	200	16	150			1.4	1.25	25	45	25	45	15	300	1.6	S-014		
SK3993	400	25	250			1.8 Max	2.5 Max	80 Max	80 Max	80 Max	100 Typ	80 Max	75 Min	3 Max	S-025		
SK4918	400	4 Max	40			1.6 Max	2 Max	3 Max	3 Max	3 Max	3 Max	5 Max	10 Min	3 Max	S-045		
SK5131	50	16	150			1.4	1.25	25	45	25	45	15	300	1.6	S-014		
SK5137	600	16	150			1.7	2.5	50					60	1.6	S-014		
SK5173	200	15	100	2	20	1.3	2.5 Max	50 Max	80 Max	50 Max	80 Max	75 Max	150	1	S-015		
SK5538	400	8	100			1.7	1.25	20	20	15	30	15	250	1.6	S-014		
SK5545	600	10 Max	120			1.6 Max	2.5 Max	50 Max	50 Max	50 Max	75 Typ	50 Max	60 Min	3 Max	S-014		
SK5550	100	2.5	25			1.7	1	1	2	1	2	2	5	1.8	S-017		
SK5551	200	2.5	25			1.7	1	1	2	1	2	2	5	1.8	S-017		
SK5552	400	2.5	25			1.7	1	1	2	1	2	2	5	1.8	S-017		
SK5555	200	0.8	8	1	5	1.5 Max	2 Max	5	5	5	5	10 Max	25	2.5	S-031		
SK5556	400	0.6	8	1	5	1.9 Max	2 Max	5	5	5	7	10 Max	25	2	S-031		
SK5557	600	0.6	8		5	1.9 Max	2 Max	5	5	5	7	10 Max	25	2	S-031		
SK5579	600	40 Max	300			1.8 Max	2.5 Max	100 Max	100 Max	100 Max	135 Typ	100 Max	60 Min	4 Max	S-025		
SK5588	200	40	300	4	30	1.65	2 Max	70 Max	70 Max	70 Max	100 Max	70 Max	50 Min	1	S-049		
SK5589	400	40	300	4	30	1.65	2 Max	70 Max	70 Max	70 Max	100 Max	70 Max	30 Min	1	S-049		
SK5590	600	40	300	4	30	1.65	2 Max	70 Max	70 Max	70 Max	100 Max	70 Max	20 Min	1	S-033		
SK5704	400	25	175	1		1.7 Max						50 Max			S-034		
SK6601	50	4	30		5	2 Max						70 Max		1.5	S-022		
SK6607	600	4	30		5	2 Max						30 Max		1.5	S-022		
SK6630	50	10	100	2		1.3	0.9	50 Max	75 Max	50 Max	75 Max	50 Max		1.5	S-019		
SK6635	600	10	100	2		1.3	0.9	50 Max	75 Max	50 Max	75 Max	50 Max		1.5	S-019		
SK6681	50	30	300			2.1	1.35	15	30	20	40	25	200	1.7	S-015		
SK6682	100	30	300			2.1	1.35	15	30	20	40	25	200	1.7	S-015		
SK6683	200	30	300			2.1	1.35	15	30	20	40	25	200	1.7	S-015		
SK6685	400	30	300			2.1	1.35	15	30	20	40	25	150	1.7	S-015		
SK6707	200	8	100			1.7	1.25	10	20	15	30	15	300	1.6	S-014		
SK6708	400	8	100			1.7	1.25	10	20	15	30	15	250	1.6	S-014		
SK6709	600	8	100			1.7	1.25	10	20	15	30	15	200	1.6	S-014		
SK6740	100	1.9	25			1.7	1	1	2	1	2	2	5	1.8	S-014		
SK9711	600	10 Max	120			1.6 Max						60 Max	175 Min	3 Max	T-096		
SK9808	400	25 Max	250			1.8 Max	2.5 Max	80 Max	80 Max	80 Max		80 Max	375 Min	4 Max	T-104		
SK9830	600	25 Max	250			1.8 Max	2.5 Max	80 Max	80 Max	80 Max		80 Max	300 Min	4 Max	T-099		

**Dimensional Outlines and Terminal Diagrams**

T-91-20

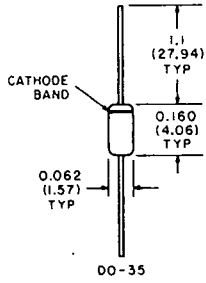

R-001

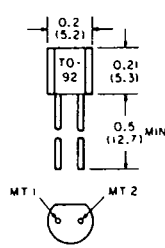

R-039

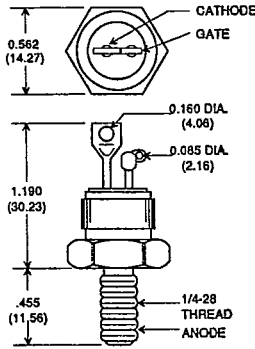

R-100

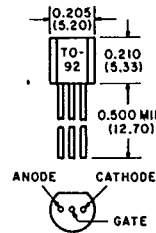

S-001

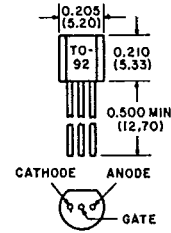

S-002

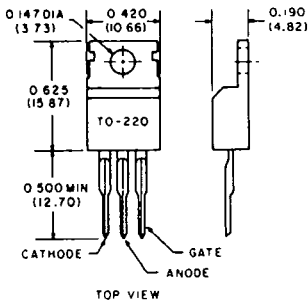

S-003

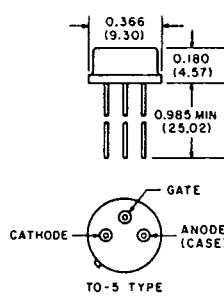

S-004

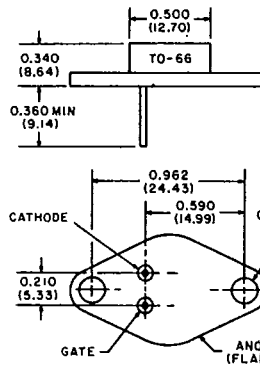

S-005

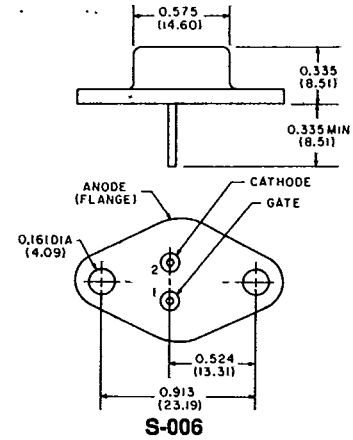

S-006

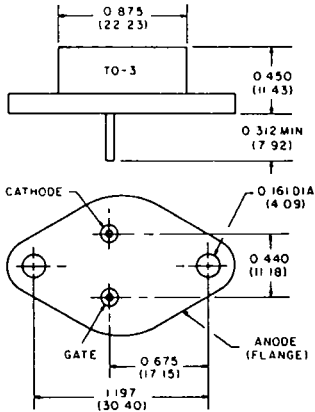

S-007

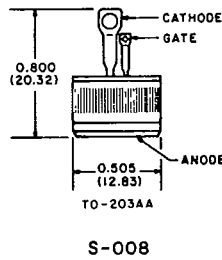

S-008

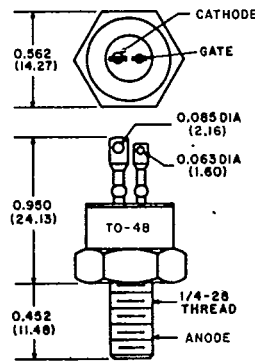

S-009

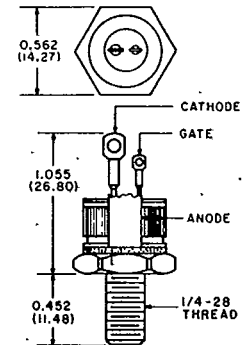

S-010

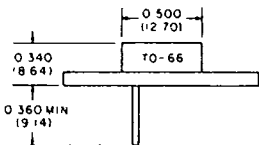

S-011

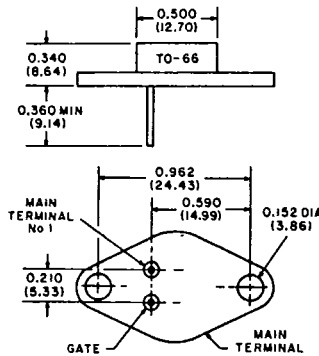

S-012

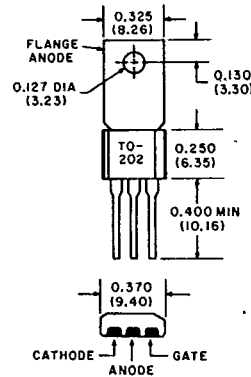

S-013

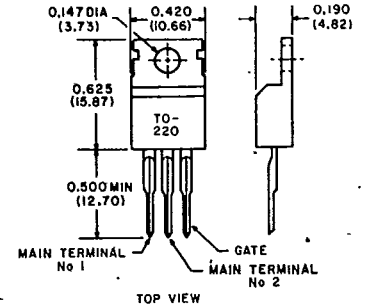

S-014

SK5538 and SK5545  
Tab Isolated

Dimensions in inches (millimeters).  
All dimensions are max. unless otherwise indicated

# Dimensional Outlines and Terminal Diagrams

T-91-20

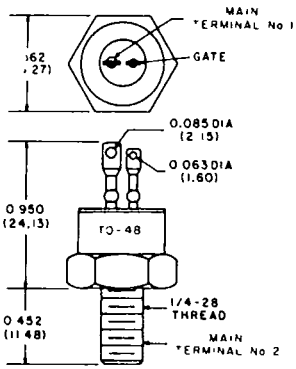

S-015

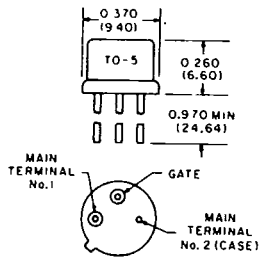

S-017

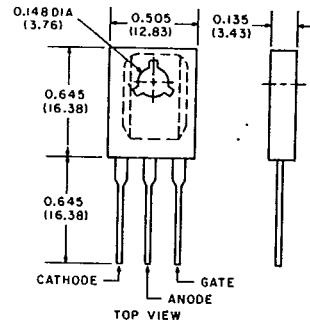

S-018

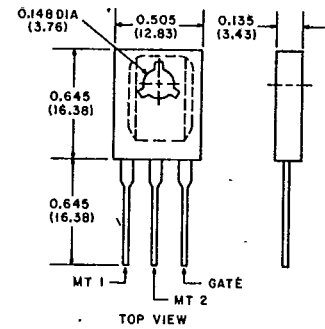

S-019

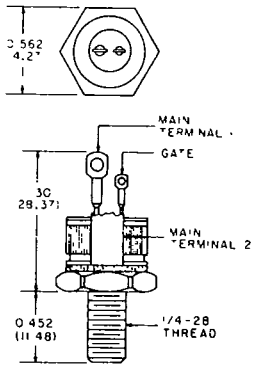

S-021

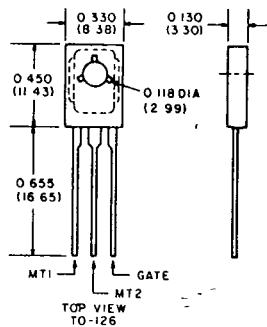

S-022

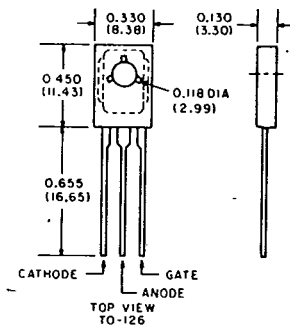

S-023

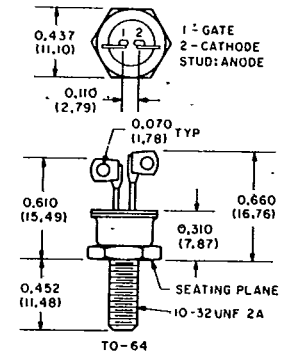

S-024

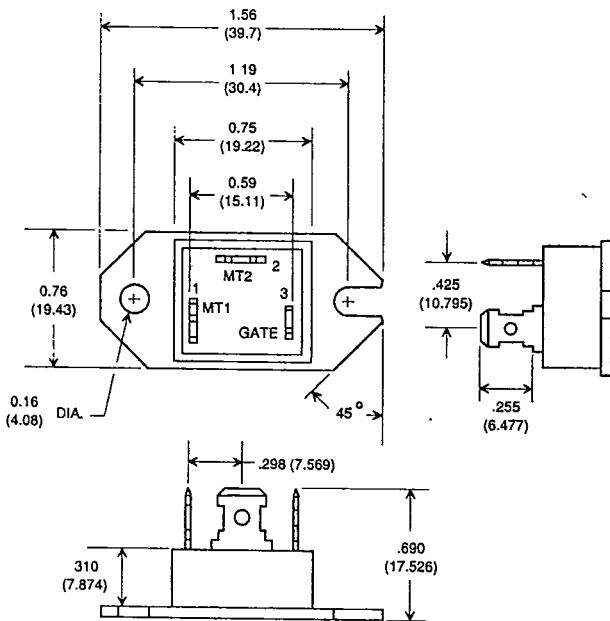

S-025

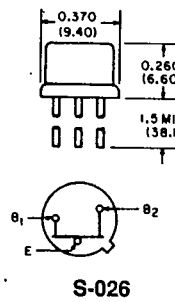

S-026

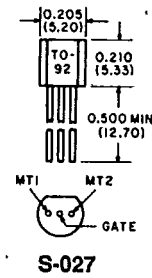

S-027

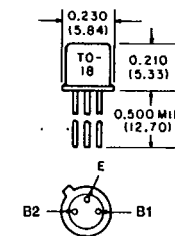

S-028

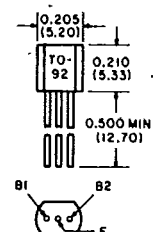

S-029

Dimensions in inches (millimeters).  
 All dimensions are max. unless otherwise indicated

Dimensional Outlines and Terminal Diagrams

T-91-20

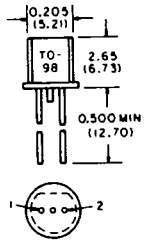

S-030

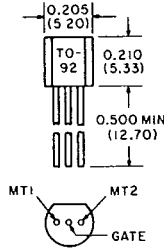

S-031

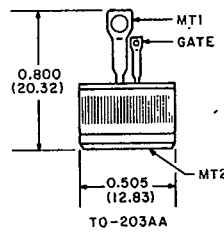

S-033

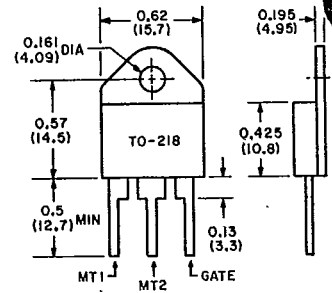

S-034

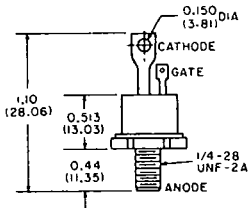
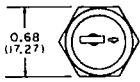

S-035

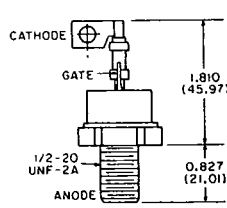
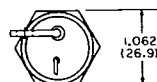

S-036

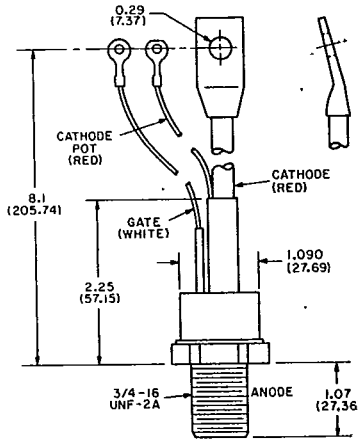

S-037

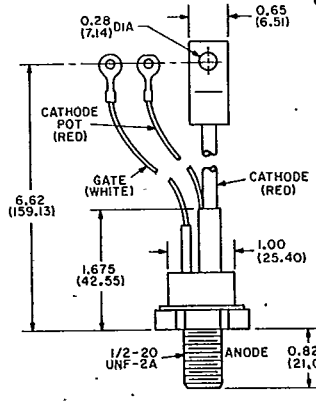

S-038

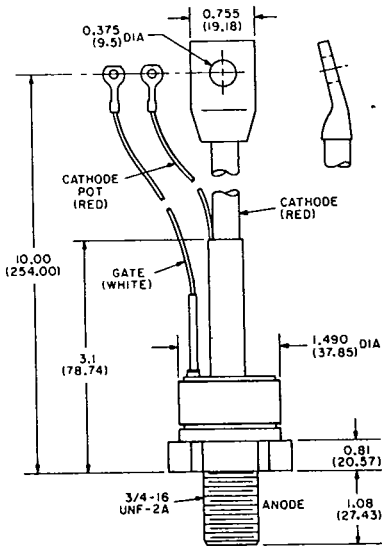

S-039

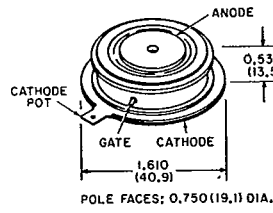

S-040

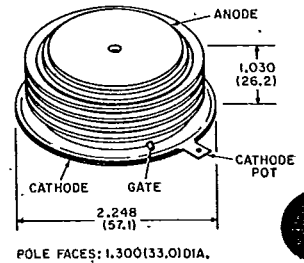

S-041

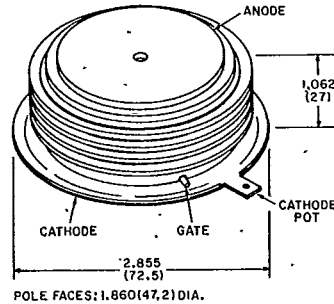

S-042

Dimensions in inches (millimeters).  
All dimensions are max. unless otherwise indicated

Dimensional Outlines and Terminal Diagrams

T-91-20

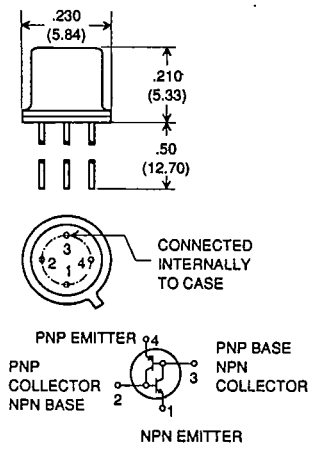

S-043

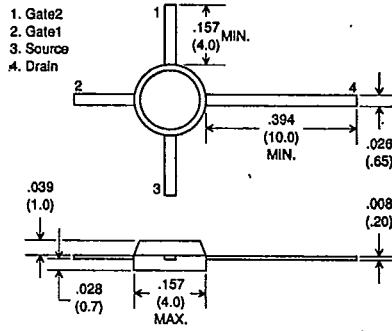

S-044

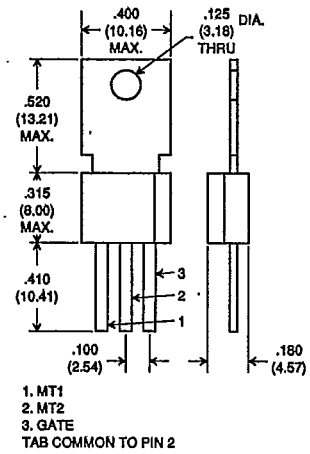

S-045

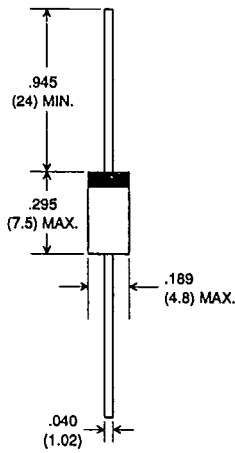

S-046

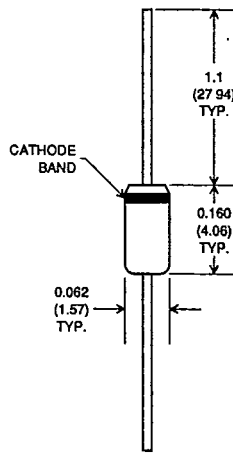

S-048

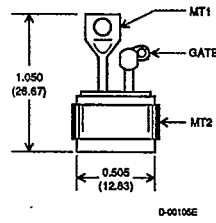

S-049

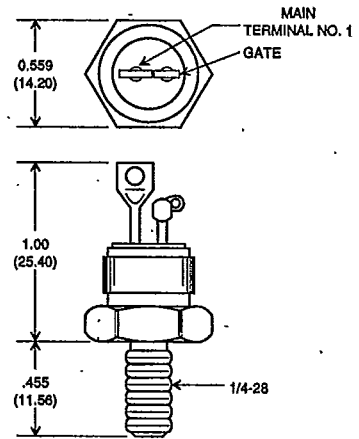

S-050

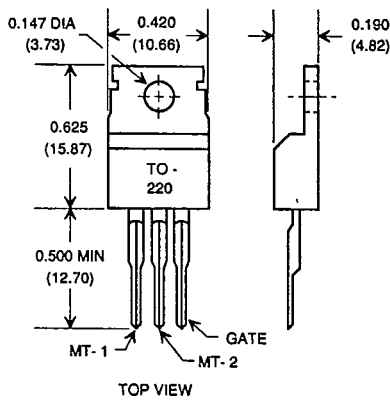

S-051

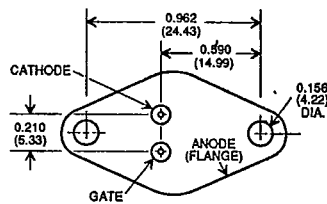

S-052

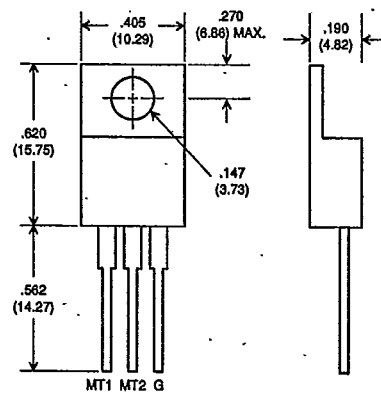

T-104

Dimensions in inches (millimeters).  
All dimensions are max. unless otherwise indicated



T-91-20

# Replacing Transistors in the JEDEC TO-219 'Plastic TO-3' Case

**Vertical-Lead  
Types (for  
TO-3 Sockets)**

**Horizontal  
Leads (for  
PC Boards)**

- 2N5034
- 2N5036
- 40514
- 40542
- 40543
- 40051 (PNP)

- 2N5035
- 2N5037
- 40513

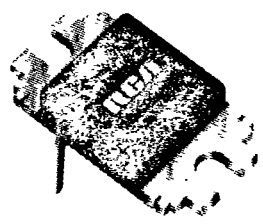

JEDEC TO-219AA



JEDEC TO-219AB

The RCA transistors above were discontinued in 1975. They were plastic versions of the JEDEC TO-3 metal case and fit a TO-3 socket. They have no "look-alike" replacements.

With the exception of type 40051, all were NPN audio frequency power types. The 40542 and 40051 were an AF complementary NPN/PNP pair.

The SK3027/130 in the TO-3 case will replace all of these types (except 40051) electrically, and is recommended to retrofit the vertical-lead devices. When 40542 and 40051 are used as complements, the recommended replacements are the complementary pair SK3297/280 (NPN) and SK3359/281 (PNP).

Extensive board modifications would be needed if a standard TO-3 were used to replace the horizontal-lead devices on a pc board. Hence, the suggested replacement is a transistor in a plastic case currently designed as a TO-3 retrofit, even though the new plastic cases do not have the base and emitter leads extended to the sides at a 90° angle. The SK3958/390 is a satisfactory electrical replacement and can be mounted on a pc board. Because the leads of these devices should not be bent to the sides, a piece of connecting wire ("spaghetti") should be used to make the connection from the base and emitter leads of the replacement to the solder point on the board.

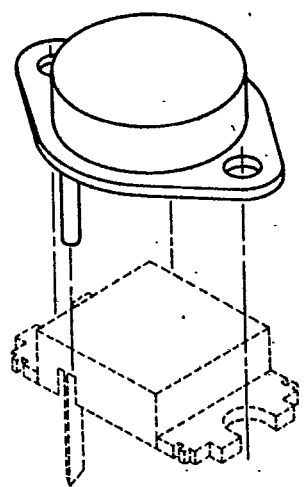
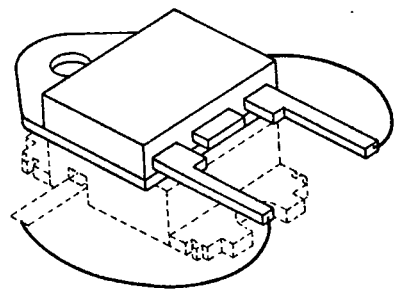

"Plastic TO-3" Retrofits

Suggested Hardware and Mounting Arrangements for Various Case Styles

TO-3/TO-204MA

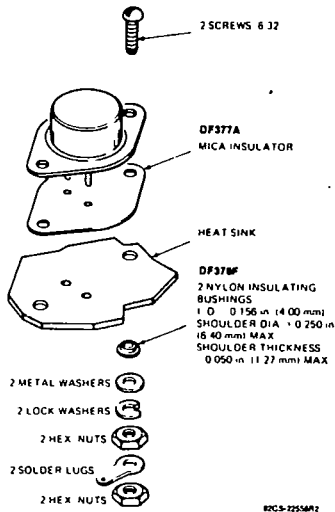

TO-8

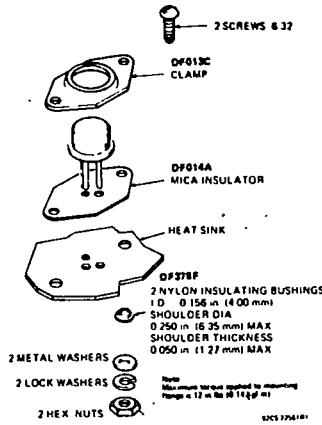

TO-61/TO-211MA

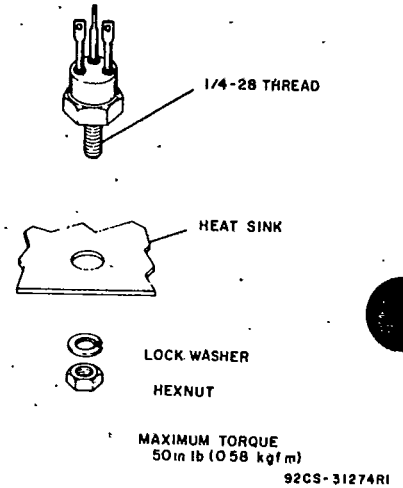

TO-5/TO-205MA  
TO-39/TO-25MD  
With Flange

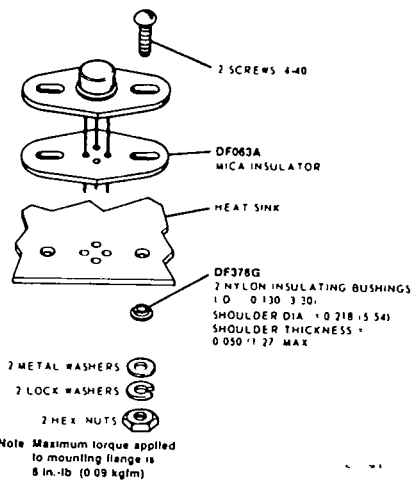

TO-48/TO-208MA

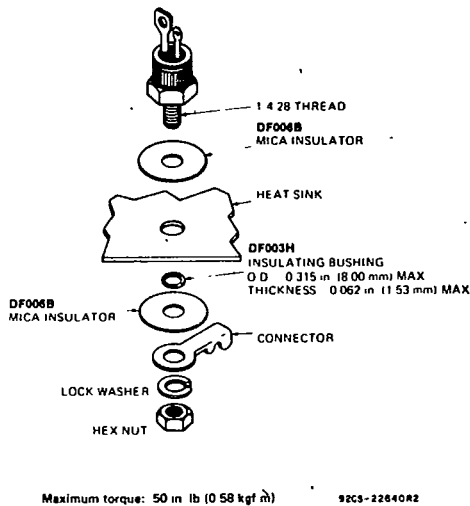

TO-66/TO-213MA

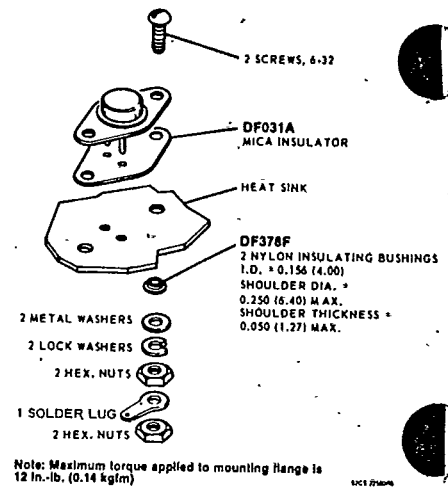

TO-202AB

