

June 1995

DESCRIPTION

The SSI 73K302L is a highly integrated single-chip modem IC which provides the functions needed to construct a Bell 202, 212A and 103 compatible modem. The SSI 73K302L is an enhancement of the SSI 73K212L single-chip modem with Bell 202 mode features added. The 73K302L is capable of 1200 or 0-300 bit/s full-duplex operation over dial-up lines. 4-wire full-duplex capability and a low speed back channel are also provided in Bell 202 mode. The SSI 73K302L recognizes and generates a 900 Hz soft carrier turn-off tone, and allows 103 for 300 bit/s FSK operation. The SSI 73K302L integrates analog, digital, and switched-capacitor array functions on a single substrate, offering excellent performance and a high level of functional integration in a single 28 or 22-pin DIP configuration. The SSI 73K302L operates from a single +5V supply with very low power consumption.

The SSI 73K302L includes the DPSK and FSK modulator/demodulator functions, call progress and hand-shake tone monitors, test modes, and a tone generator capable of producing DTMF, answer, and 900 Hz soft carrier turn-off tone. This device supports Bell 202, 212A and 103 modes of operation, allowing both

(continued)

FEATURES

- One-chip Bell 212A, 103 and 202S/T standard compatible modem data pump
- Full-duplex operation at 0-300 bit/s (FSK), 1200 bit/s (DPSK) or 0-1200 bit/s (FSK) forward channel with or without 0-150 bit/s back channel
- Full-duplex 4-wire operation in Bell 202 mode
- Pin and software compatible with other SSI K-Series 1-chip modems
- Interfaces directly with standard microprocessors (8048, 80C51 typical)
- Serial (22-pin DIP) or parallel microprocessor bus for control
- Serial port for data transfer
- Both synchronous and asynchronous modes of operation
- Call progress, carrier, precise answer tone (2225 Hz), soft carrier turn-off (SCT), and FSK mark detectors
- DTMF, answer, and SCT tone generators
- Test modes available: ALB, DL, RDL, Mark, Space, Alternating bit patterns
- CMOS technology for low power consumption using 35 mW @ 5V from a single power supply

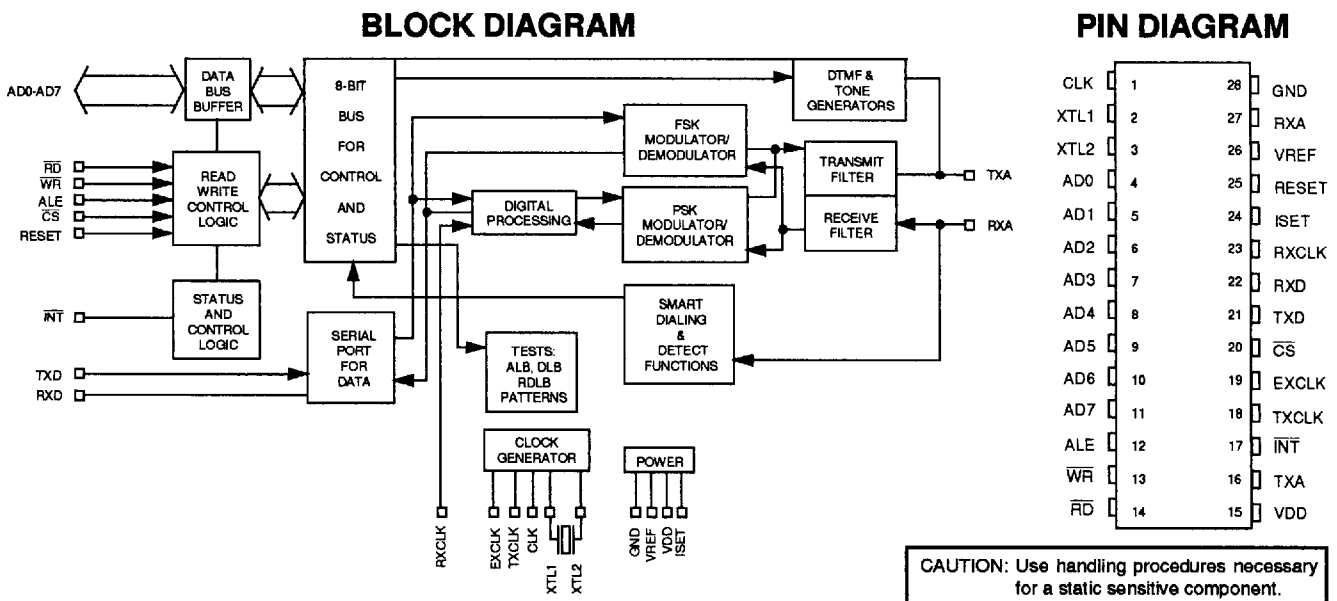

SSI 73K302L

Bell 212A, 103, 202

Single-Chip Modem

DESCRIPTION (continued)

synchronous and asynchronous communications. The SSI 73K302L is designed to appear to the systems designer as a microprocessor peripheral, and will easily interface with popular one-chip microprocessors (80C51 typical) for control of modem functions through its 8-bit multiplexed address/data bus or via an optional serial command bus. An ALE control line simplifies address demultiplexing. Data communications occurs through a separate serial port only.

The SSI 73K302L is ideal for use in either free standing or integral system modem products where multi-standard data communications is desired. Its high functionality, low power consumption and efficient packaging simplify design requirements and increase system reliability. A complete modem requires only the addition of the phone line interface, a modem controller, and RS232 level converter for a typical system.

Tri-mode capability in one-chip allows full-duplex Bell 212 and 103 operation or asymmetrical Bell 202S operation over the 2-wire switched telephone network. 202T mode full-duplex operation at 1200 bit/s is also possible when operating on 4-wire leased lines.

A soft carrier turn-off feature facilitates fast line turn around when using the 202S mode for half-duplex applications.

The SSI 73K302L is part of Silicon Systems K-Series family of pin and function compatible single-chip modem products. These devices allow systems to be configured for higher speeds and Bell or CCITT operation with only a single component change.

OPERATION

ASYNCHRONOUS MODE

Data transmission for the DPSK mode requires that data ultimately be transmitted in a synchronous fashion. The SSI 73K302L includes ASYNC/SYNC and SYNC/ASYNC converters which delete or insert stop bits in order to transmit data at a regular rate. In asynchronous mode the serial data comes from the TXD pin into the ASYNC/SYNC converter. The ASYNC/SYNC converter accepts the data provided on the TXD pin which normally must be 1200 bit/s $\pm 1.0\%$, 2.5% . The rate converter will then insert or delete stop bits in order to output a signal which is 1200 bit/s $\pm .01\%$

($\pm 0.01\%$ is the required synchronous data rate accuracy).

The SYNC/ASYNC converter also has an extended overspeed mode which allows selection of an output overspeed range of either $+1\%$ or $+2.3\%$. In the extended overspeed mode, stop bits are output at $7/8$ the normal width.

The serial data stream from the transmit buffer or the rate converter is passed through the data scrambler and onto the analog modulator. The data scrambler can be bypassed under processor control when unscrambled data must be transmitted. If serial input data contains a break signal through one character (including start and stop bits) the break will be extended to at least $2 \cdot N + 3$ bits long (where N is the number of transmitted bits/character).

Serial data from the demodulator is passed first through the data descrambler and then through the SYNC/ASYNC converter. The ASYNC/ASYNC converter will reinsert any deleted stop bits and output data at an intra-character rate (bit-to-bit timing) of no greater than 1219 bit/s. An incoming break signal (low through two characters) will be passed through without incorrectly inserting a stop bit.

SYNCHRONOUS MODE

The Bell 212A standard defines synchronous operation at 1200 bit/s. Operation is similar to that of the asynchronous mode except that data must be synchronized to a provided clock and no variation in data transfer rate is allowable. Serial input data appearing at TXD must be valid on the rising edge of TXCLK.

TXCLK is an internally derived signal in internal mode and is connected internally to the RXCLK pin in slave mode. Receive data at the RXD pin is clocked out on the falling edge of RXCLK. The ASYNCH/SYNCH converter is bypassed when synchronous mode is selected and data is transmitted out at the same rate as it is input.

DPSK MODULATOR/DEMODULATOR

In DPSK mode the SSI 73K302L modulates a serial bit stream into di-bit pairs that are represented by four possible phase shifts as prescribed by the Bell 212A standards. The base-band signal is then filtered to reduce intersymbol interference on the bandlimited 2-wire telephone line. Transmission occurs using ei-

SSI 73K302L

Bell 212A, 103, 202

Single-Chip Modem

ther a 1200 Hz (originate mode) or 2400 Hz (answer mode) carrier. Demodulation is the reverse of the modulation process, with the incoming analog signal eventually decoded into di-bits and converted back to a serial bit stream. The demodulator also recovers the clock which was encoded into the analog signal during modulation. Demodulation occurs using either a 1200 Hz carrier (answer mode or ALB originate mode) or a 2400 Hz carrier (originate mode or ALB answer mode). The SSI 73K302L uses a phase locked loop coherent demodulation technique for optimum receiver performance.

FSK MODULATOR/DEMODULATOR

The FSK modulator produces a frequency modulated analog output signal using two discrete frequencies to represent the binary data. Bell 103 mode uses 1270 and 1070 Hz (originate, mark and space) or 2225 and 2025 Hz (answer, mark and space). Bell 202 mode uses 1200 and 2200 Hz for the main channel and 387 and 487 Hz for the back channel. The modulation rate of the back channel is up to 150 baud. Demodulation involves detecting the received frequencies and decoding them into the appropriate binary value. The rate converter and scrambler/descrambler are automatically bypassed in the 103 or 202 modes.

PASSBAND FILTERS AND EQUALIZERS

High and low band filters are included to shape the amplitude and phase response of the transmit and receive signals and provide compromise delay equalization and rejection of out-of-band signals in the receive channel. Amplitude and phase equalization are necessary to compensate for distortion of the transmission line and to reduce intersymbol interference in the bandlimited receive signal. The transmit signal filtering approximates a 75% square root of raised Cosine frequency response characteristic.

AGC

The automatic gain control maintains a signal level at the input to the demodulators which is constant to within 1 dB. It corrects quickly for increases in signal which would cause clipping and provides a total receiver dynamic range of >45 dB.

PARALLEL BUS INTERFACE

Four 8-bit registers are provided for control, option select and status monitoring. These registers are ad-

dressed with the AD0, AD1, and AD2 multiplexed address lines (latched by ALE) and appear to a control microprocessor as four consecutive memory locations. Two control registers and the tone register are read/write memory. The detect register is read only and cannot be modified except by modem response to monitored parameters. The parallel bus interface is not available in the 22-pin package.

SERIAL COMMAND INTERFACE

The serial command interface allows access to the SSI 73K302L control and status registers via a serial command port. In this mode the A0, A1 and A2 lines provide register addresses for data passed through the data pin under control of the \overline{RD} and \overline{WR} lines. A read operation is initiated when the \overline{RD} line is taken low. The first bit is available after \overline{RD} is brought low and the next seven cycles of EXCLK will then transfer out seven bits of the selected address location LSB first. A write takes place by shifting in eight bits of data LSB first for eight consecutive cycles of EXCLK. \overline{WR} is then pulsed low and data transfer into the selected register occurs on the rising edge of \overline{WR} .

SPECIAL DETECT CIRCUITRY

The special detect circuitry monitors the received analog signal to determine status or presence of carrier, answer tone and weak received signal (long loop condition), special tones such as FSK marking and the 900 Hz soft carrier turn-off tone are also detected. A highly frequency selective call progress detector provides adequate discrimination to accurately detect lower quality call progress signals.

DTMF GENERATOR

The DTMF generator will output one of 16 standard tone pairs determined by a 4-bit binary value and TX DTMF mode bit previously loaded into the tone register. Tone generation is initiated when the DTMF mode is selected using the tone register and the transmit enable (CR0 bit D1) is changed from 0 to 1.

SOFT CARRIER TURN-OFF TONE GENERATOR

The soft carrier turn-off tone generator will output a 900 Hz tone. When activated in Bell 202 main channel transmit mode, the output signal will shift to 900 Hz, maintaining phase continuity during the transition.

SSI 73K302L
Bell 212A, 103, 202
Single-Chip Modem

PIN DESCRIPTION

POWER

NAME	28-PIN	22-PIN	TYPE	DESCRIPTION
GND	28	1	I	System Ground.
VDD	15	11	I	Power supply input, 5V ±10%. Bypass with 0.1 and 22 μF capacitors to GND.
VREF	26	21	O	An internally generated reference voltage. Bypass with 0.1 μF capacitor to GND.
ISET	24	19	I	Chip current reference. Sets bias current for op-amps. The chip current is set by connecting this pin to VDD through a 2 MΩ resistor. ISET should be bypassed to GND with a 0.1 μF capacitor.

PARALLEL MICROPROCESSOR INTERFACE

ALE	12	-	I	Address latch enable. The falling edge of ALE latches the address on AD0-AD7 and the chip select on CS.
AD0-AD7	4-11	-	I/O	Address/data bus. These bidirectional tri-state multiplexed lines carry information to and from the internal registers.
\overline{CS}	20	-	I	Chip select. A low on this pin during the falling edge of ALE allows a read cycle or a write cycle to occur. AD0-AD7 will not be driven and no registers will be written if \overline{CS} (latched) is not active. The state of \overline{CS} is latched on the falling edge of ALE.
CLK	1	2	O	Output clock. This pin is selectable under processor control to be either the crystal frequency (for use as a processor clock) or 16 x the data rate for use as a baud rate clock in DPSK mode only. The pin defaults to the crystal frequency on reset.
\overline{INT}	17	13	O	Interrupt. This open drain output signal is used to inform the processor that a detect flag has occurred. The processor must then read the detect register to determine which detect triggered the interrupt. \overline{INT} will stay low until the processor reads the detect register or does a full reset.
\overline{RD}	14	-	I	Read. A low requests a read of the SSI 73K302L internal registers. Data cannot be output unless both \overline{RD} and the latched \overline{CS} are active or low.
RESET	25	20	I	Reset. An active high signal on this pin will put the chip into an inactive state. All control register bits (CR0, CR1, Tone) will be reset. The output of the CLK pin will be set to the crystal frequency. An internal pull down resistor permits power on reset using a capacitor to VDD.

SSI 73K302L
Bell 212A, 103, 202
Single-Chip Modem

PARALLEL MICROPROCESSOR INTERFACE (continued)

NAME	28-PIN	22-PIN	TYPE	DESCRIPTION
\overline{WR}	13	-	I	Write. A low on this informs the SSI 73K302L that data is available on AD0-AD7 for writing into an internal register. Data is latched on the rising edge of \overline{WR} . No data is written unless both \overline{WR} and the latched \overline{CS} are active low.

SERIAL MICROPROCESSOR INTERFACE

A0-A2	-	5-7	I	Register Address Selection. These lines carry register addresses and should be valid during any read or write operation.
DATA	-	8	I/O	Serial Control Data. Data for a read/write operation is clocked in or out on the falling edge of the EXCLK pin. The direction of data flow is controlled by the \overline{RD} pin. \overline{RD} low outputs data. \overline{RD} high inputs data.
\overline{RD}	-	10	I	Read. A low on this input informs the SSI 73K302L that data or status information is being read by the processor. The falling edge of the \overline{RD} signal will initiate a read from the addressed register. The \overline{RD} signal must continue for eight falling edges of EXCLK in order to read all eight bits of the referenced register. Read data is provided LSB first. Data will not be output unless the \overline{RD} signal is active.
\overline{WR}	-	9	I	Write. A low on this input informs the SSI 73K302L that data or status information has been shifted in through the DATA pin and is available for writing to an internal register. The normal procedure for a write is to shift in data LSB first on the DATA pin for eight consecutive falling edges of EXCLK and then to pulse \overline{WR} low. Data is written on the rising edge of \overline{WR} .

Note: In the serial, 22-pin version, the pins AD0-AD7, ALE and \overline{CS} are removed and replaced with the pins; A0, A1, A2, DATA, and an unconnected pin. Also, the \overline{RD} and \overline{WR} controls are used differently. The serial control mode is provided in the parallel control versions by tying ALE high and \overline{CS} low. In this configuration AD7 becomes DATA and AD0, AD1 and AD2 become A0, A1 and A2, respectively.

SSI 73K302L
Bell 212A, 103, 202
Single-Chip Modem

PIN DESCRIPTION (continued)

DTE USER INTERFACE

NAME	28-PIN	22-PIN	TYPE	DESCRIPTION
EXCLK	19	15	I	External Clock. This signal is used only in synchronous DPSK transmission when the external timing option has been selected. In the external timing mode the rising edge of EXCLK is used to strobe synchronous DPSK transmit data available on the TXD pin. Also used for serial control interface.
RXCLK	23	18	O	Receive Clock. The falling edge of this clock output is coincident with the transitions in the serial received DPSK data output. The rising edge of RXCLK can be used to latch the valid output data. RXCLK will be valid as long as a carrier is present. In Bell 202 mode a clock which is 16 x 1200 or 16 x 150 baud data rate is output.
RXD	22	17	O/ Weak Pull-up	Received Data Output. Serial receive data is available on this pin. The data is always valid on the rising edge of RXCLK when in synchronous mode. RXD will output constant marks if no carrier is detected.
TXCLK	18	14	O	Transmit Clock. This signal is used only in synchronous DPSK transmission to latch serial input data on the TXD pin. Data must be provided so that valid data is available on the rising edge of the TXCLK. The transmit clock is derived from different sources depending upon the synchronization mode selection. In Internal Mode the clock is 1200 Hz generated internally. In External Mode TXCLK is phase locked to the EXCLK pin. In Slave Mode TXCLK is phase locked to the RXCLK pin. TXCLK is always active. In Bell 202 mode the output is a 16 x 1200 baud clock or 16 x 150 baud to drive a UART.
TXD	21	16	I	Transmit Data Input. Serial data for transmission is applied on this pin. In synchronous modes, the data must be valid on the rising edge of the TXCLK clock. In asynchronous modes (1200 or 300 baud) no clocking is necessary. DPSK must be 1200 bit/s +1%, -2.5% or +2.3%, -2.5% in extended overspeed mode.

ANALOG INTERFACE AND OSCILLATOR

RXA	27	22	I	Received modulated analog signal input from the telephone line interface.
TXA	16	12	O	Transmit analog output to the telephone line interface.
XTL1 XTL2	2 3	3 4	I I	These pins are for the internal crystal oscillator requiring a 11.0592 MHz parallel mode crystal and two load capacitors to Ground. XTL2 can also be driven from an external clock.

SSI 73K302L

Bell 212A, 103, 202

Single-Chip Modem

REGISTER DESCRIPTIONS

Four 8-bit internal registers are accessible for control and status monitoring. The registers are accessed in read or write operations by addressing the A0 and A1 address lines in serial mode, or the AD0 and AD1 lines in parallel mode. The AD0 and AD1 lines are latched by ALE. Register CR0 controls the method by which data is transferred over the phone line. CR1 controls the

interface between the microprocessor and the SSI 73K302L internal state. DR is a detect register which provides an indication of monitored modem status conditions. TR, the tone control register, controls the DTMF generator, answer and guard tones and RXD output gate used in the modem initial connect sequence. All registers are read/write except for DR which is read only. Register control and status bits are identified below:

REGISTER BIT SUMMARY

REGISTER	ADDRESS		DATA BIT NUMBER							
	AD2 - AD0		D7	D6	D5	D4	D3	D2	D1	D0
CONTROL REGISTER 0 CR0	000		MODULATION OPTION	0	TRANSMIT MODE 3	TRANSMIT MODE 2	TRANSMIT MODE 1	TRANSMIT MODE 0	TRANSMIT ENABLE	ANSWER/ORIGINATE
CONTROL REGISTER 1 CR1	001		TRANSMIT PATTERN 1	TRANSMIT PATTERN 0	ENABLE DETECT INTERRUPT	BYPASS SCRAMBLER/ ADD PH. EQ. 202	CLK CONTROL	RESET	TEST MODE 1	TEST MODE 0
DETECT REGISTER DR	010		X	X	RECEIVE DATA	UNSCR. MARKS	CARRIER DETECT	SPECIAL TONE	CALL PROGRESS	LONG LOOP
TONE CONTROL REGISTER TR	011		RXD OUTPUT CONTROL	TRANSMIT SCT TONE	TRANSMIT ANSWER TONE	TRANSMIT DTMF	DTMF3	DTMF/ 202T FDX	DTMF/ OVERSPEED	DTMF/ SPEC. TONE/ ANSWER TONE/ SELECT
ID REGISTER ID	110		ID	ID	ID	ID	X	X	X	X

NOTE: When a register containing reserved control bits is written into, the reserved bits must be programmed as 0's.

X = Undefined, mask in software

SSI 73K302L

Bell 212A, 103, 202

Single-Chip Modem

REGISTER ADDRESS TABLE

REGISTER	ADDRESS		DATA BIT NUMBER							
	AD2 - AD0		D7	D6	D5	D4	D3	D2	D1	D0
CONTROL REGISTER 0	CR0	000	MODULATION OPTION	0	TRANSMIT MODE 3	TRANSMIT MODE 2	TRANSMIT MODE 1	TRANSMIT MODE 0	TRANSMIT ENABLE	ORIGINATE/ANSWER
			0=103 FSK 1=202 FSK	0000=PWR DOWN 1100=FSK 0010=EXT SYNCH 0011=SLAVE SYNCH 0100=ASYNCH 8 BITS/CHAR 0101=ASYNCH 9 BITS/CHAR 0110=ASYNCH 10 BITS/CHAR 0111=ASYNCH 11 BITS/CHAR 1100=FSK BELL 103 OR 202				0=DISABLE TXA OUTPUT 1=ENABLE TXA OUTPUT	IN 212, 103 MODES: 0=ANSWER 1=ORIGINATE IN 202 MODE: 0=RECEIVE @ 1200 BIT/S, TRANSMIT @ 150 BIT/S 1=RECEIVE @ 150 BIT/S, TRANSMIT @ 1200 BIT/S	
CONTROL REGISTER 1	CR1	001	TRANSMIT PATTERN 1	TRANSMIT PATTERN 0	ENABLE DETECT INTERRUPT	BYPASS SCRAMBLER/ADD PH. EQ.	CLK CONTROL	RESET	TEST MODE 1	TEST MODE 0
			00=TX DATA 01=TX ALTERNATE 10=TX MARK 11=TX SPACE	0=ENABLE 1=DISABLE	0=NORMAL 1=BYPASS SCRAMBLER 1=ADD EXTRA PHASE EQ. IN 202 ONLY	0=XTAL 1=16 X DATA RATE OUTPUT AT CLK PIN IN DPSK MODE ONLY	0=NORMAL 1=RESET	00=NORMAL 01=ANALOG LOOPBACK 10=REMOTE DIGITAL LOOPBACK 11=LOCAL DIGITAL LOOPBACK		
DETECT REGISTER	DR	010	X	X	RECEIVE DATA	UNSCR. MARKS	CARRIER DETECT	SPECIAL TONE	CALL PROGRESS	LONG LOOP
					OUTPUTS RECEIVED DATA STREAM	0=CONDITION NOT DETECTED 1=CONDITION DETECTED				
STONE CONTROL REGISTER	TR	011	RXD OUTPUT CONTROL	TRANSMIT SCT TONE	TRANSMIT ANSWER TONE	TRANSMIT DTMF	DTMF3	DTMF2/202T FDX	DTMF1/OVERSPPEED	DTMF0/SPECIAL TONE
			RXD PIN 0=NORMAL 1=TRI STATE	0=OFF 1=ON	0=OFF 1=ON	0=DATA 1=TX DTMF	4 BIT CODE FOR 1 OF 16 DUAL TONE COMBINATIONS. 0=NORMAL OPERATION 1=FULL DUPLEX IN 202 MODE		0=1% 1=2.5%	0=900 HZ SCT TONE IF IN ANSWER MODE =2225 HZ ANSWER TONE IN 103 OR 212 ORIGINATE MODES 1=FSK MARK
ID REGISTER	10	110	ID	ID	ID	ID	X	X	X	X

00XX=73K212L, 322L, 321L
 01XX=73K221L, 302L
 10XX=73K222L
 1100=73K224L
 1110=73K324L

X = Undefined, mask in software
 0 = Only write zeros to this location

SSI 73K302L
Bell 212A, 103, 202
Single-Chip Modem

CONTROL REGISTER 0

	D7	D6	D5	D4	D3	D2	D1	D0						
CR0 000	MODUL. OPTION	0	TRANSMIT MODE 3	TRANSMIT MODE 2	TRANSMIT MODE 1	TRANSMIT MODE 0	TRANSMIT ENABLE	ANSWER/ ORIGINATE						
BIT NO.	NAME	CONDITION	DESCRIPTION											
D0	Answer/ Originate	0	Selects answer mode in 103 and 212A modes (transmit in high band, receive in low band) or in Bell 202 mode, receive at 1200 bit/s and transmit at 150 bit/s.											
		1	Selects originate mode in 103 and 212A modes (transmit in low band, receive in high band) or in Bell 202 mode, receive at 150 bit/s and transmit at 1200 bit/s.											
		Note: This bit works with TR bit D0 to program special tones detected in Tone Register. See detect and tone registers.												
D1	Transmit Enable	0	Disables transmit output at TXA.											
		1	Enables transmit output at TXA. Note: Answer tone and DTMF TX control require TX enable.											
D5, D4,D3, D2	Transmit Mode	D5 D4 D3 D2												
		0 0 0 0							Selects power down mode. All functions disabled except digital interface.					
		0 0 0 1							Internal synchronous mode. In this mode TXCLK is an internally derived 1200 Hz signal. Serial input data appearing at TXD must be valid on the rising edge of TXCLK. Receive data is clocked out of RXD on the falling edge of RXCLK.					
		0 0 1 0							External synchronous mode. Operation is identical to internal synchronous, but TXCLK is connected internally to EXCLK pin, and a 1200 Hz \pm 0.01% clock must be supplied externally.					
		0 0 1 1							Slave synchronous mode. Same operation as other synchronous modes. TXCLK is connected internally to the RXCLK pin in this mode.					
		0 1 0 0							Selects DPSK asynchronous mode - 8 bits/character (1 start bit, 6 data bits, 1 stop bit).					
		0 1 0 1							Selects DPSK asynchronous mode - 9 bits/character (1 start bit, 7 data bits, 1 stop bit).					
		0 1 1 0							Selects DPSK asynchronous mode - 10 bits/character (1 start bit, 8 data bits, 1 stop bit).					
		0 1 1 1							Selects DPSK asynchronous mode - 11 bits/character (1 start bit, 8 data bits, Parity and 1 or 2 stop bits).					
		1 1 0 0							Selects 103 or 202 FSK operation.					

SSI 73K302L
Bell 212A, 103, 202
Single-Chip Modem

CONTROL REGISTER 0 (continued)

	D7	D6	D5	D4	D3	D2	D1	D0
CR0 000	MODUL. OPTION	0	TRANSMIT MODE 3	TRANSMIT MODE 2	TRANSMIT MODE 1	TRANSMIT MODE 0	TRANSMIT ENABLE	ANSWER/ ORIGINATE
BIT NO.	NAME	CONDITION		DESCRIPTION				
D6		0		Not used; must be written as a "0."				
D7	Modulation Option	D7 D5 D4		Selects:				
		X 0 X	DPSK asynchronous mode at 1200 bit/s.					
		0 1 1	FSK Bell 103 mode.					
		1 1 1	FSK Bell 202 mode.					

CONTROL REGISTER 1

	D7	D6	D5	D4	D3	D2	D1	D0
CR1 001	TRANSMIT PATTERN 1	TRANSMIT PATTERN 0	ENABLE DETECT INTER.	BYPASS SCRAMB/ ADD PH. EQ.	CLK CONTROL	RESET	TEST MODE 1	TEST MODE 0
BIT NO.	NAME	CONDITION		DESCRIPTION				
D1, D0	Test Mode	D1 D0		Selects normal operating mode.				
		0 0						
		0 1		Analog loopback mode. Loops the transmitted analog signal back to the receiver, and causes the receiver to use the same center frequency as the transmitter. To squelch the TXA pin, transmit enable must be forced low. Not supported in FDX202 mode.				
		1 0		Selects remote digital loopback. Received data is looped back to transmit data internally, and RXD is forced to a mark. Data on TXD is ignored.				
		1 1		Selects local digital loopback. Internally loops TXD back to RXD and continues to transmit carrier from TXA pin.				
D2	Reset	0		Selects normal operation.				
		1		Resets modem to power down state. All control register bits (CR0, CR1, Tone) are reset to zero. The output of the CLK pin will be set to the crystal frequency.				

SSI 73K302L
Bell 212A, 103, 202
Single-Chip Modem

CONTROL REGISTER 1 (continued)

	D7	D6	D5	D4	D3	D2	D1	D0						
CR1 001	TRANSMIT PATTERN 1	TRANSMIT PATTERN 0	ENABLE DETECT INTER.	BYPASS SCRAMB/ ADD PH. EQ.	CLK CONTROL	RESET	TEST MODE 1	TEST MODE 0						
BIT NO.	NAME	CONDITION	DESCRIPTION											
D3	CLK Control	0	Selects 11.0592 MHz crystal echo output at CLK pin.											
		1	Selects 16 X the data rate, output at CLK pin in DPSK modes only.											
D4*	Bypass Scrambler/ Add Phase Equalization	0	Selects normal operation. DPSK data is passed through scrambler.											
		1	Selects Scrambler Bypass. DPSK data is routed around scrambler in the transmit path. In Bell 202 mode, additional phase equalization is added to the main channel filters when D4 is set to 1.											
D5	Enable Detect Interrupt	0	Disables interrupt at $\overline{\text{INT}}$ pin.											
		1	Enables $\overline{\text{INT}}$ output. An interrupt will be generated with a change in status of DR bits D1-D4. The special tone and call progress detect interrupts are masked when the TX enable bit is set. Carrier detect is masked when TX DTMF is activated. All interrupts will be disabled if the device is in power down mode.											
D7, D6	Transmit Pattern	D7 D6	Selects normal data transmission as controlled by the state of the TXD pin.											
		0 0												
		0 1							Selects an alternating mark/space transmit pattern for modem testing.					
		1 0							Selects a constant mark transmit pattern.					
		1 1							Selects a constant space transmit pattern.					
* D4 should always be set to 1 when receiving 1200 bit/s data and to 0 when transmitting 1200 bit/s data in 202 mode.														

SSI 73K302L
Bell 212A, 103, 202
Single-Chip Modem

DETECT REGISTER

	D7	D6	D5	D4	D3	D2	D1	D0
DR 010	X	X	RECEIVE DATA	UNSCR. MARK	CARR. DETECT	SPECIAL TONE	CALL PROG.	LONG LOOP
BIT NO.	NAME		CONDITION	DESCRIPTION				
D0	Long Loop		0	Indicates normal received signal.				
			1	Indicates low received signal level.				
D1	Call Progress Detect		0	No call progress tone detected.				
			1	Indicates presence of call progress tones. The call progress detection circuitry is activated by energy in the normal 350 to 620 Hz call progress band.				
D2	Special Tone Detect		0	No special tone detected as programmed by CR0 bit D0 and Tone Register bit D0.				
			1	Special tone detected. The detected tone is:				
				(1) 2225 Hz answer tone if D0 of TR=0 and the device is in Bell 103 or 212A originate mode.				
				(2) Soft carrier turn-off tone if D0 of TR=0 and the device is in Bell 202 answer mode.				
				(3) an FSK mark in the mode the device is set to receive if D0 of TR is set to 1.				
Tolerance on special tones is $\pm 3\%$.								
D3	Carrier Detect		0	No carrier detected in the receive channel.				
			1	Indicated carrier has been detected in the received channel.				
D4	Unscrambled Mark Detect		0	No unscrambled mark.				
			1	(DPSK only) Indicates detection of unscrambled marks in the received data. A valid indication requires that unscrambled marks be received for $>165.5 \pm 6.5$ ms.				
D5	Receive Data			Continuously outputs the received data stream. This data is the same as that output on the RXD pin, but it is not disabled when RXD is tri-stated.				
D6, D7	Not Used		Undefined	Mask in software				

SSI 73K302L
Bell 212A, 103, 202
Single-Chip Modem

TONE REGISTER

	D7	D6	D5	D4	D3	D2	D1	D0		
TR 011	RXD OUTPUT CONTR.	TRANSMIT SOFT CARRIER TURN-OFF TONE	TRANSMIT ANSWER TONE	TRANSMIT DTMF	DTMF 3	DTMF 2/ 202 FDX	DTMF 1/ OVER- SPEED	DTMF 0/ SPECIAL TONE SEL		
BIT NO.	NAME	CONDITION	DESCRIPTION							
D0	DTMF 0/ Special Tone Detect/Select	D5 D4 D0	D0 interacts with bits D6, D4, and CR0 as shown.							
		0 1 X	Transmit DTMF tones.							
		0 0 0	2225 Hz answer tone will be detected in D2 of DR if originate mode is selected in CR0.							
		X 0 1	900 Hz SCT tone will be detected in D2 of DR if Bell 202 answer mode is selected in CR0.							
		1 0 1	Mark of an FSK mode selected in CR0 is to be detected in D2 of DR.							
		1 0 0	2225 Hz answer tone will be generated when in answer mode and transmit enable is selected in CR0.							
		1 0 1	2100 Hz answer tone will be generated when in answer mode and transmit enable is selected in CR0.							
D1	DTMF 1/ Overspeed	D4 D1	D1 interacts with D4 as shown.							
		0 0	Asynchronous DPSK 1200 bit/s +1.0% -2.5%.							
		0 1	Asynchronous DPSK 1200 bit/s +2.3% -2.5%.							
D2	DTMF2/202T FDX	0	Enables 202 half-duplex operation if TR D4=0							
		1	Enables 202 full-duplex operation if TR D4=0							
D3, D2, D1, D0	DTMF 3, 2, 1, 0	D3 D2 D1 D0	Programs 1 of 16 DTMF tone pairs that will be transmitted when TX DTMF and TX enable bit (CR0, bit D1) are set. Tone encoding is shown below:							
		0 0 0 0 - 1 1 1 1								
		KEYBOARD EQUIVALENT	DTMF CODE D3 D2 D1 D0	TONES LOW HIGH						
		1	0 0 0 1	697 1209						
		2	0 0 1 0	697 1336						
		3	0 0 1 1	697 1477						
		4	0 1 0 0	770 1209						
		5	0 1 0 1	770 1336						
		6	0 1 1 0	770 1477						
		7	0 1 1 1	852 1209						
		8	1 0 0 0	852 1336						
		9	1 0 0 1	852 1477						
0	1 0 1 0	941 1336								

SSI 73K302L
Bell 212A, 103, 202
Single-Chip Modem

ID REGISTER

ID 110	D7	D6	D5	D4	D3	D2	D1	D0
	ID	ID	ID	ID	X	X	X	X
BIT NO.	NAME		CONDITION		DESCRIPTION			
D7, D6, D5, D4	Device Identification Signature		D7 D6 D5 D4	Indicates Device:				
			0 0 X X	SSI 73K212L, 73K321L or 73K322L or 73K321L				
			0 1 X X	SSI 73K221L or 73K302L				
			1 0 X X	SSI 73K222L				
			1 1 0 0	SSI 73K224L				
D3-D0	Not Used		Undefined		Mask in software			

ELECTRICAL SPECIFICATIONS

ABSOLUTE MAXIMUM RATINGS

PARAMETER	RATING
VDD Supply Voltage	14V
Storage Temperature	-65 to 150°C
Soldering Temperature (10 sec.)	260°C
Applied Voltage	-0.3 to VDD+0.3V

Note: All inputs and outputs are protected from static charge using built-in, industry standard protection devices and all outputs are short-circuit protected.

RECOMMENDED OPERATING CONDITIONS

PARAMETER	CONDITION	MIN	NOM	MAX	UNIT
VDD Supply voltage		4.5	5	5.5	V
TA, Operating Free-Air Temp.		-40		+85	°C
Clock Variation	(11.0592 MHz) Crystal or external clock	-0.01		+0.01	%
External Components (Refer to Application section for placement.)					
VREF Bypass Capacitor	(External to GND)	0.1			μF
Bias setting resistor	(Placed between VDD and ISET pins)	1.8	2	2.2	MΩ
ISET Bypass Capacitor	(ISET pin to GND)	0.1			μF
VDD Bypass Capacitor 1	(External to GND)	0.1			μF
VDD Bypass Capacitor 2	(External to GND)	22			μF
XTL1 Load Capacitor	Depends on crystal characteristics; from pin to GND			40	pF
XTL2 Load Capacitor				20	

SSI 73K302L
Bell 212A, 103, 202
Single-Chip Modem

ELECTRICAL SPECIFICATIONS (continued)

DC ELECTRICAL CHARACTERISTICS

(TA = -40°C to 85°C, VDD = recommended range unless otherwise noted.)

PARAMETER	CONDITION	MIN	NOM	MAX	UNIT
IDD, Supply Current	ISET Resistor = 2 MΩ				
IDDA, Active	CLK = 11.0592 MHz		8	12	mA
IDD1, Power-down	CLK = 11.0592 MHz			4	mA
IDD2, Power-down	CLK = 19.200 kHz			3	mA
Digital Inputs					
VIH, Input High Voltage					
Reset, XTL1, XTL2		3.0		VDD	V
All other inputs		2.0		VDD	V
VIL, Input Low Voltage		0		0.8	V
IIH, Input High Current	VI = VIH Max			100	μA
IIL, Input Low Current	VI = VIL Min	-200			μA
Reset Pull-down Current	Reset = VDD	1		50	μA
Input Capacitance	All Digital Input Pins			10	pF
Digital Outputs					
VOH, Output High Voltage	IOH MIN = -0.4 mA	2.4		VDD	V
VOL, Output Low Voltage	IO MAX = 1.6 mA			0.4	V
VOL, CLK Output	IO = 3.6 mA			0.6	V
RXD Tri-State Pull-up Curr.	RXD = GND	-1		-50	μA
CMAX, CLK Output	Maximum Capacitive Load			15	pF
Capacitance					
Inputs	Capacitance, all Digital Input pins			10	pF
XTL1, 2 Load Capacitors	Depends on crystal	15		60	pF
CLK	Maximum Capacitive Load			15	pF

SSI 73K302L
Bell 212A, 103, 202
Single-Chip Modem

DYNAMIC CHARACTERISTICS AND TIMING

(TA = -40°C to +85°C, VDD = recommended range unless otherwise noted.)

PARAMETER	CONDITION	MIN	NOM	MAX	UNIT
DPSK Modulator					
Carrier Suppression	Measured at TXA	45			dB
Output Amplitude	TX scrambled marks	-11	-10	-9	dBm0
FSK Modulator					
Output Freq. Error	CLK = 11.0592 MHz	-0.35		+0.35	%
Transmit Level	Transmit Dotting Pattern	-11	-10	-9	dBm0
Soft Carrier Turnoff Tone		-11.9	-10.9	-9.9	dBm0
Harmonic Distortion in 700-2900 Hz band	THD in the alternate band DPSK or FSK		-60	-50	dB
Output Bias Distortion	Transmit Dotting Pattern In ALB @ RXD		±3		%
Total Output Jitter	Random Input in ALB @ RXD	-10		+10	%
DTMF Generator	Must not be in 202 mode				
Freq. Accuracy		-0.25		+0.25	%
Output Amplitude, Low group	DPSK mode	-10	-9	-8	dBm0
Output Amplitude, High group	DPSK mode	-8	-7	-6	dBm0
Twist	High-Band to Low-Band	1.0	2.0	3.0	dB
Long Loop Detect	With Sinusoid	-38		-28	dBm0
Dynamic Range	Refer to Performance Curves		45		dB
<p>Note: Parameters expressed in dBm0 refer to the following definition:</p> <p style="margin-left: 40px;">5V Version: 0 dB loss in the Transmit path to the line. 2 dB gain in the Receive path from the line.</p> <p style="margin-left: 40px;">Refer to the Basic Box Modem diagram in the Applications section for the DAA design.</p>					

SSI 73K302L
 Bell 212A, 103, 202
 Single-Chip Modem

DYNAMIC CHARACTERISTICS AND TIMING (continued)

PARAMETER	CONDITION	MIN	NOM	MAX	UNIT
Call Progress Detector					
Detect Level	-3 dB points in 285 and 675 Hz	-38			dBm0
Reject Level	Test signal is a 460 Hz sinusoid			-45	dBm0
Delay Time	-70 dBm0 to -30 dBm0 STEP	20		40	ms
Hold Time	-30 dBm0 to -70 dBm0 STEP	20		40	ms
Hysteresis		2			dB
Carrier Detect					
Threshold	DPSK or FSK receive data	-49		-42	dBm0
Delay Time					
Bell 103		8		20	ms
Bell 212A		15		32	ms
Bell 202 Forward Channel		6		12	ms
Bell 202 Back Channel		25		40	ms
Hold Time					
Bell 103		6		20	ms
Bell 212A		10		24	ms
Bell 202 Forward Channel		3		8	ms
Bell 202 Back Channel		10		25	ms
Hysteresis		2			dB
Special Tone Detectors					
Detect Level	See definitions for TR bit D0 mode	-49		-42	dBm0
Delay Time					
Answer tone		10		25	ms
900 Hz SCT tone	Preceded by valid carrier*	4		10	ms
202 Main Channel Mark		10		25	ms
202 Back Channel Mark		20		65	ms
1270 or 2225 Hz marks		10		25	ms

* If SCT duration >4ms, it is guaranteed to detect.

SSI 73K302L
Bell 212A, 103, 202
Single-Chip Modem

DYNAMIC CHARACTERISTICS AND TIMING (continued)

PARAMETER	CONDITION	MIN	NOM	MAX	UNIT
Special Tone Detectors (continued)					
Hold Time					
Answer tone		4		15	ms
900 Hz SCT tone		1		10	ms
202 Main Channel Mark		3		10	ms
202 Back Channel Mark		10		25	ms
1270 or 2225 Hz marks		5		15	ms
Hysteresis		2			dB
Detect Freq. Range	Any Special Tone	-3		+3	%
Output Smoothing Filter					
Output load	TXA pin; FSK Single Tone out for THD = -50 dB in 0.3 to 3.4 kHz	10			k Ω
				50	pF
Out of Band Energy	Frequency >12 kHz in all modes See Transmit Energy Spectrum			-60	dBm0
Output Impedance	TXA pin		20	50	Ω
Clock Noise	TXA pin; 76.8 kHz or 122.88 kHz in 202 main channel		0.1	0.4	mVrms
Carrier VCO					
Capture Range	Originate or Answer	-10		+10	Hz
Capture Time	-10 Hz to +10 Hz Carrier Frequency Change		40	100	ms
DPSK Recovered Clock					
Capture Range	% of data rate (center at 1200 Hz)	-625		+625	ppm
Data Delay Time	Analog data in at RXA pin to receive data valid at RXD pin		30	50	ms
Tone Generator					
Tone Accuracy	DTMF or FSK tones	-5		+5	Hz
Tone Level	For DTMF, must not be in 202 mode	-1		+1	dB

SSI 73K302L
Bell 212A, 103, 202
Single-Chip Modem

DYNAMIC CHARACTERISTICS AND TIMING (continued)

PARAMETER	CONDITION	MIN	NOM	MAX	UNIT
Timing (Refer to Timing Diagrams)					
TAL	\overline{CS} /Addr. setup before ALE Low	25			ns
TLA	\overline{CS} /Addr. hold after ALE Low	20			ns
TLC	ALE Low to $\overline{RD}/\overline{WR}$ Low	30			ns
TCL	$\overline{RD}/\overline{WR}$ Control to ALE High	-5			ns
TRD	Data out from \overline{RD} Low	0		140	ns
TLL	ALE width	30			ns
TRDF	Data float after \overline{RD} High	0		5	ns
TRW	\overline{RD} width	200		25000	ns
TWW	\overline{WR} width	140		25000	ns
TDW	Data setup before \overline{WR} High	40			ns
TWD	Data hold after \overline{WR} High	10			ns
TCKD	Data out after EXCLK Low			200	ns
TCKW	\overline{WR} after EXCLK Low	150			ns
TDCK	Data setup before EXCLK Low	150			ns
TAC	Address setup before control*	50			ns
TCA	Address hold after control*	50			ns
TWH	Data Hold after EXCLK	20			
* Control for setup is the falling edge of \overline{RD} or \overline{WR} . Control for hold is the falling edge of \overline{RD} or the rising edge of \overline{WR} .					

NOTE: Asserting ALE, \overline{CS} , and \overline{RD} or \overline{WR} concurrently can cause unintentional register accesses. When using non-8031 compatible processors, care must be taken to prevent this from occurring when designing the interface logic.

TIMING DIAGRAMS

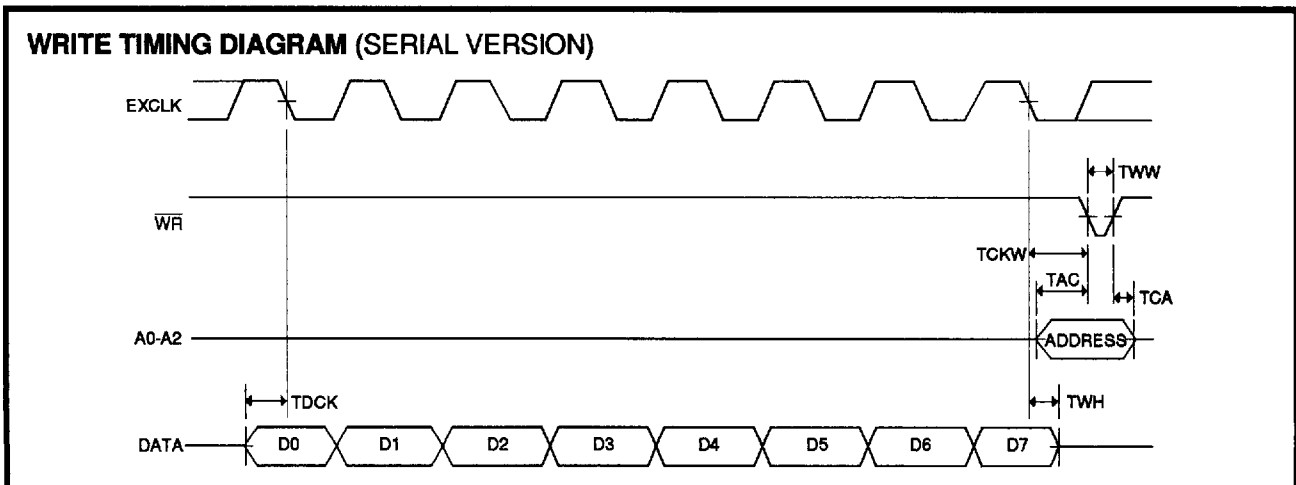
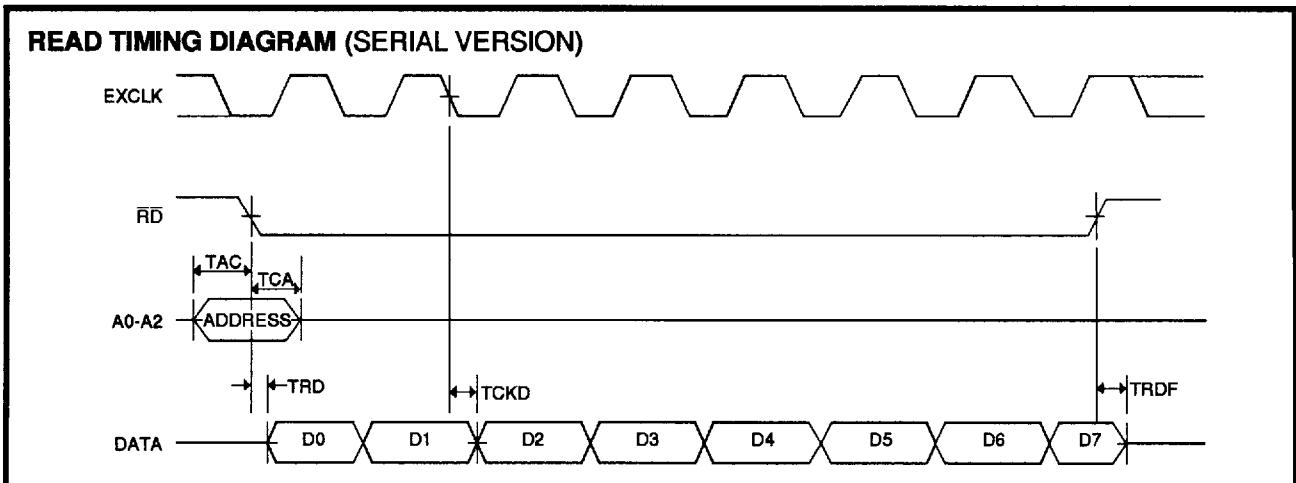
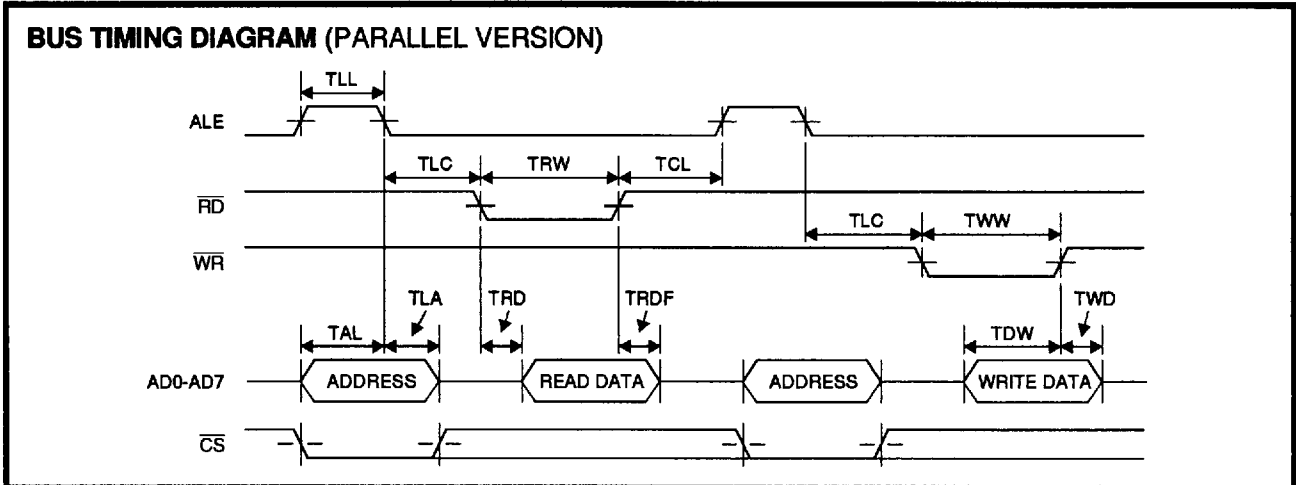

SSI 73K302L

Bell 212A, 103, 202

Single-Chip Modem

APPLICATIONS INFORMATION

GENERAL CONSIDERATIONS

Figures 1 and 2 show basic circuit diagrams for K-Series modem integrated circuits. K-Series products are designed to be used in conjunction with a control processor, a UART or RS-232 serial data interface, and a DAA phone line interface to function as a typical intelligent modem. The K-Series ICs interface directly with Intel 8048 and 80C51 microprocessors for control and status monitoring purposes. Two typical DAA arrangements are shown: one for a split ± 5 or ± 12 volt design and one for a single 5V design. These diagrams are for reference only and do not represent production-ready modem designs.

K-Series devices are available with two control interface versions: one for a parallel multiplexed address/data interface, and one for a serial interface. The parallel version is intended for use with 8039/48 or 8031/51 microcontrollers from Intel or many other manufacturers. The serial interface 22-pin version can be used with other microcontrollers or in applications where only a limited number of port lines are available or the application does not lend itself to a multiplexed address/data interface. The parallel versions may also be used in the serial mode, as explained in the data sheet pin description.

In most applications the controller will monitor the serial data for commands from the DTE and the received data for break signals from the far end modem. In this way, commands to the modem are sent over the same line as the transmitted data. In other applications the RS-232 interface handshake lines are used for modem control.

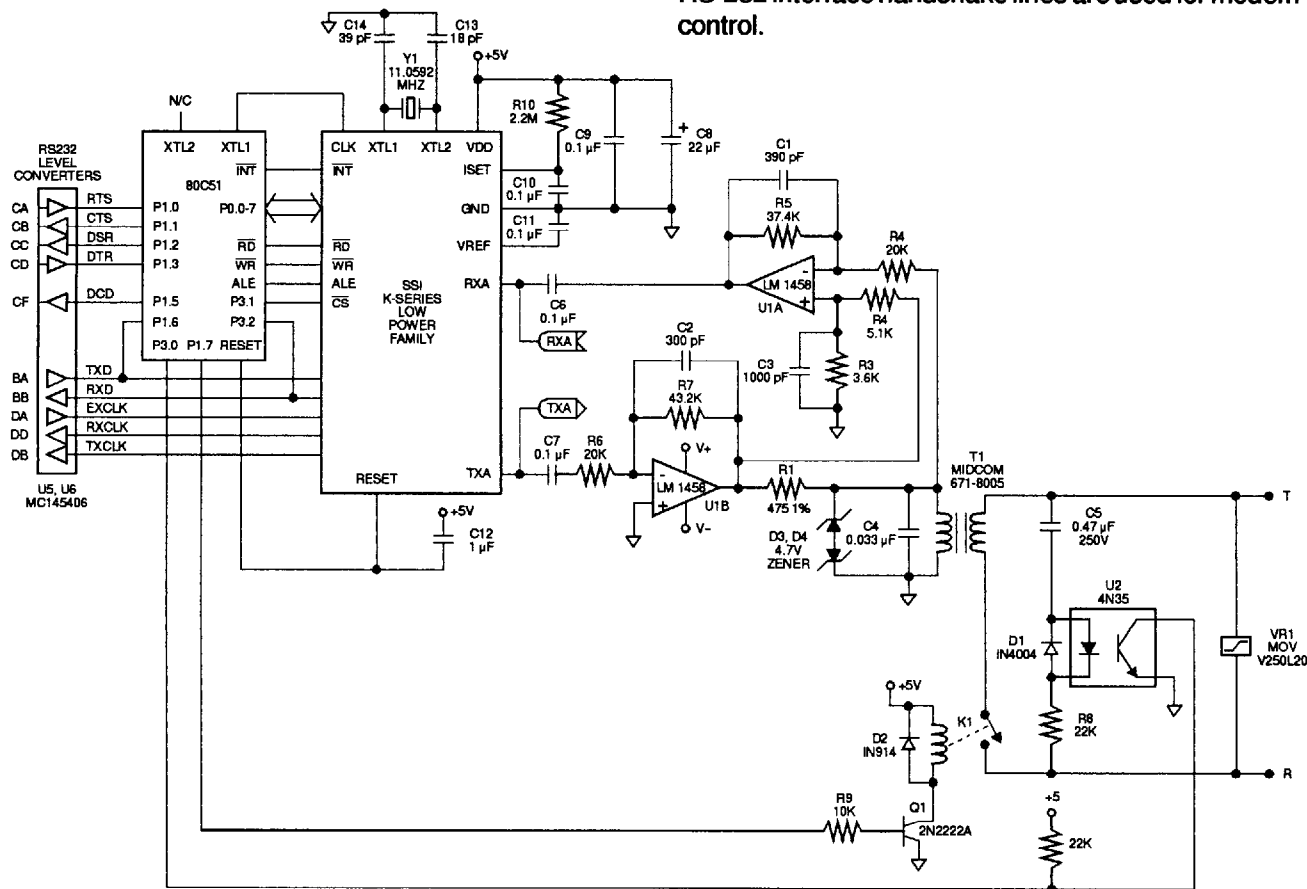

FIGURE 1: Basic Box Modem with Dual-Supply Hybrid

SSI 73K302L

Bell 212A, 103, 202

Single-Chip Modem

Unlike digital logic circuitry, modem designs must properly contend with precise frequency tolerances and very low level analog signals, to ensure acceptable performance. Using good analog circuit design practices will generally result in a sound design. Following are additional recommendations which should be taken into consideration when starting new designs.

CRYSTAL OSCILLATOR

The K-Series crystal oscillator requires a parallel mode (antiresonant) crystal which operates at 11.0592 MHz. It is important that this frequency be maintained to within $\pm 0.01\%$ accuracy.

In order for a parallel mode crystal to operate correctly and to specification, it must have a load capacitor connected to the junction of each of the crystal and internal inverter connections, terminated to ground. The values of these capacitors depend primarily on the crystal's characteristics, and to a lesser degree on the internal inverter circuit. The values used affect the accuracy and start up characteristics of the oscillator.

LAYOUT CONSIDERATIONS

Good analog/digital design rules must be used to control system noise in order to obtain highest performance in modem designs. The more digital circuitry present on the PC board, the more this attention to noise control is needed. The modem should be treated as a high impedance analog device. A 22 μF electrolytic capacitor in parallel with a 0.1 μF ceramic capacitor between VDD and GND is recommended. Liberal use of ground planes and larger traces on power and ground are also highly favored. High speed digital circuits tend to generate a significant amount of EMI (Electro-Magnetic Interference) which must be minimized in order to meet regulatory agency limitations. To accomplish this, high speed digital devices should be locally bypassed, and the telephone line interface and K-Series device should be located close to each other near the area of the board where the phone line connection is accessed. To avoid problems, power supply and ground traces should be routed separately to the analog and digital functions on the board, and digital signals should not be routed near low level or high impedance analog traces. The analog and digital grounds should only connect at one point near the K-Series device ground pin to avoid ground loops. The K-Series modem IC's should have both high frequency and low frequency bypassing as close to the package as possible.

MODEM PERFORMANCE CHARACTERISTICS

The curves presented here define modem IC performance under a variety of line conditions while inducing disturbances that are typical of those encountered during data transmission on public service telephone lines. Test data was taken using an AEA Electronics' "Autotest I" modem test set and line simulator, operating under computer control. All tests were run full-duplex, using a Concord Data Systems 224 as the reference modem. A 511 pseudo-random-bit pattern was used for each data point. Noise was C-message weighted and all signal-to-noise (S/N) ratios reflect total power measurements similar to the CCITT V.56 measurement specification. The individual tests are defined as follows.

BER vs. S/N

This test measures the ability of the modem to operate over noisy lines with a minimum of data-transfer errors. Since some noise is generated in the best of dial-up lines, the modem must operate with the lowest S/N ratio possible. Better modem performance is indicated by test curves that are closest to the BER axis. A narrow spread between curves representing the four line parameters indicates minimal variation in performance while operating over a range of aberrant operating conditions. Typically, a DPSK modem will exhibit better BER-performance test curves receiving in the low band than in the high band.

BER vs. Receive Level

This test measures the dynamic range of the modem. Because signal levels vary widely over dial-up lines, the widest possible dynamic range is desirable. The minimum Bell specification calls for 36 dB of dynamic range. S/N ratios are held constant at the indicated values while the receive level is lowered from a very high to very low signal levels. The width of the "bowl" of these curves, taken at the BER point, is the measure of dynamic range.

SSI 73K302L

Bell 212A, 103, 202

Single-Chip Modem

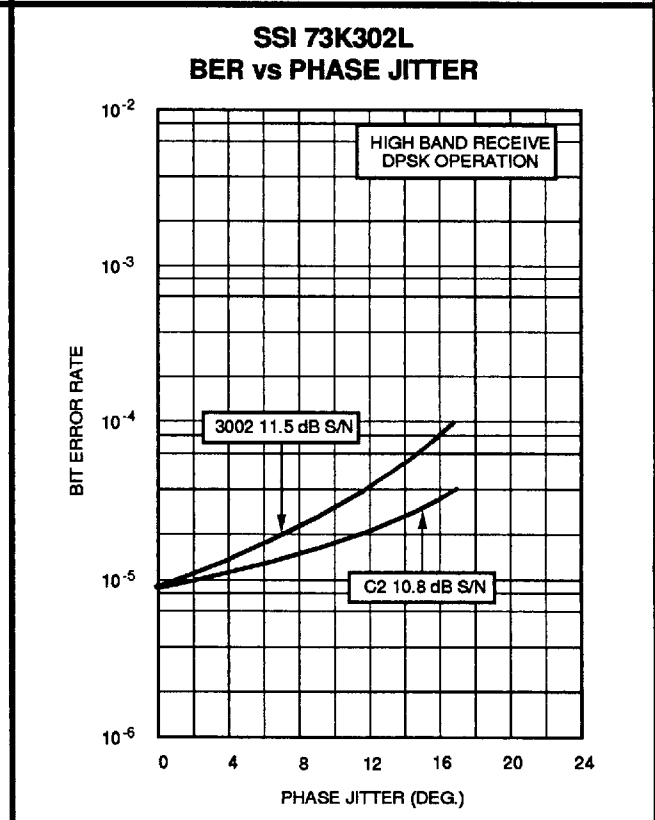
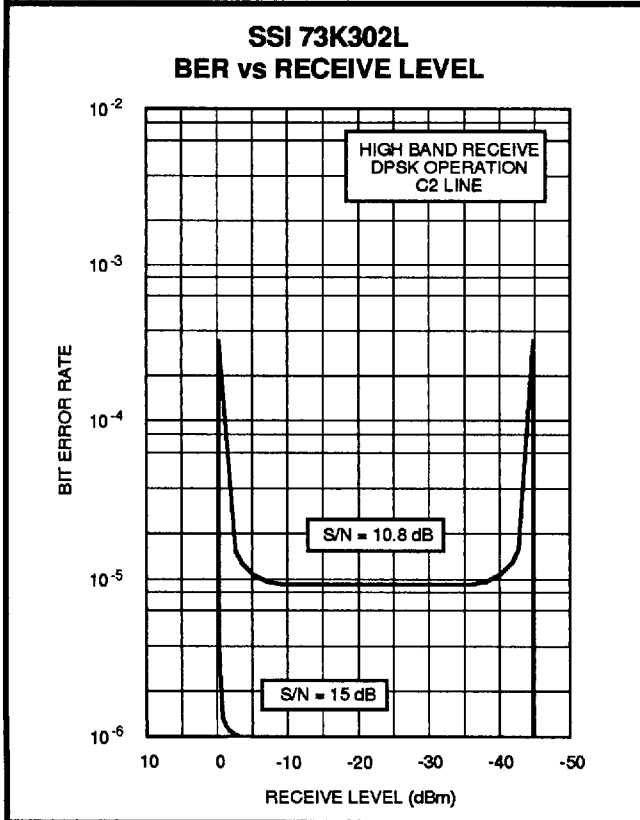
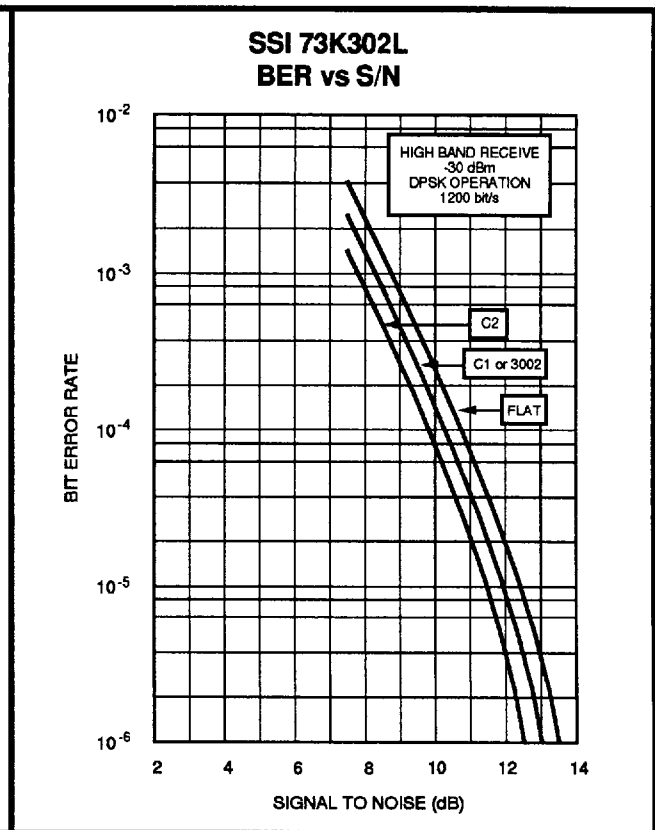
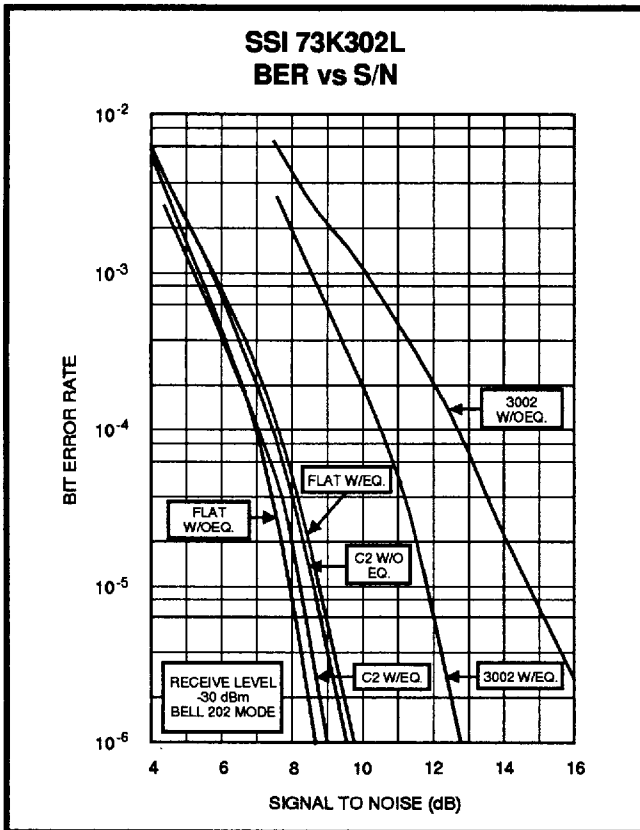

SSI 73K302L

Bell 212A, 103, 202

Single-Chip Modem

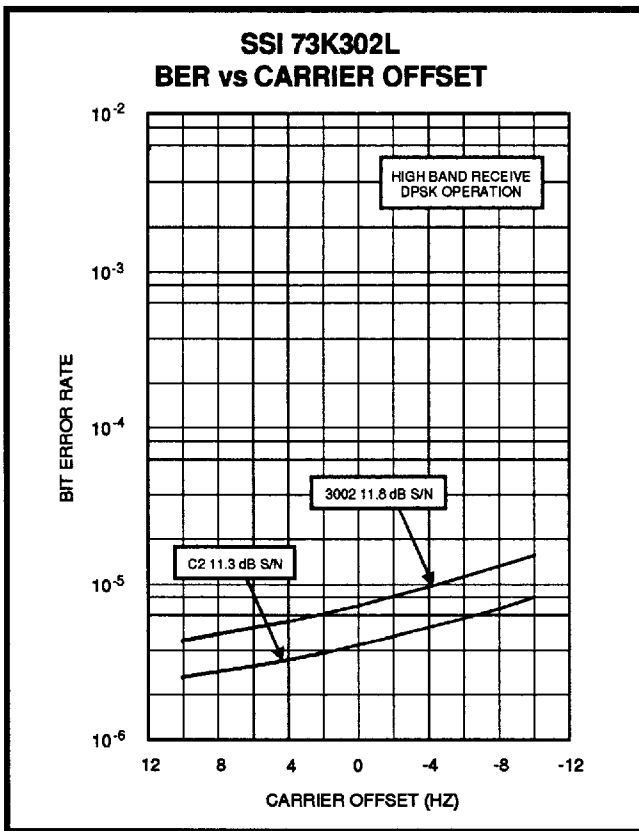

SSI 73K302L

Bell 212A, 103, 202

Single-Chip Modem

PACKAGE PIN DESIGNATIONS

(Top View)

CAUTION: Use handling procedures necessary for a static sensitive component.

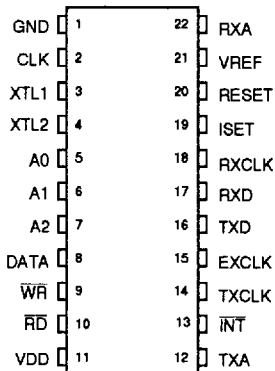

400-Mil
22-Pin DIP

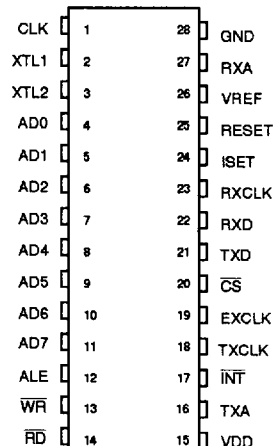

600-Mil
28-Pin DIP

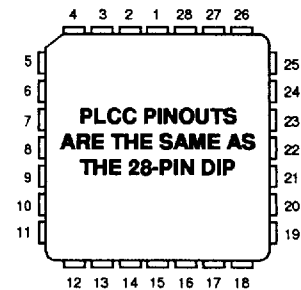

28-Pin
PLCC

PLCC PINOUTS
ARE THE SAME AS
THE 28-PIN DIP

ORDERING INFORMATION

PART DESCRIPTION	ORDER NO.	PKG. MARK
SSI 73K302L		
28-Pin Plastic Dual In-Line	73K302L-IP	73K302L-IP
28-Lead Plastic Leaded Chip Carrier	73K302L-IH	73K302L-IH
SSI 73K302L with Serial Interface		
22-pin Plastic Dual In-Line	73K302SL-IP	73K302SL-IP

Preliminary Data: Indicates a product not completely released to production. The specifications are based on preliminary evaluations and are not guaranteed. Small quantities are available, and Silicon Systems should be consulted for current information.

No responsibility is assumed by Silicon Systems for use of this product nor for any infringements of patents and trademarks or other rights of third parties resulting from its use. No license is granted under any patents, patent rights or trademarks of Silicon Systems. Silicon Systems reserves the right to make changes in specifications at any time without notice. Accordingly, the reader is cautioned to verify that the data sheet is current before placing orders.

Silicon Systems, Inc., 14351 Myford Road, Tustin, CA 92680-7022, (714) 573-6000, FAX: (714) 573-6914