

- NOTES: UNLESS OTHERWISE SPECIFIED
1. FOR USE WITH RG-8, 8A, 11, 11A AND 213/U CABLE.
 2. FOR CABLING INSTRUCTION, SEE CP-480.
 3. FOR CABLE CRIMPING, USE DIE KTH-2003.
 4. FOR CABLE TRIMMING, USE KTJ-137 AND KTD-138.
 5. INTERFACE PER MIL-STD-348, FIG. 304-1.
 6. MATERIALS:
 INSULATOR: TEFLON PER ASTM D-4894
 GASKET: SILICON RUBBER PER ZZ-R-765
 OUTER CONTACT AND C-RING: PHOS. BRONZE PER ASTM B-103
 ALL OTHER METAL PARTS; BRASS PER ASTM B-16
 7. FINISHES:
 CENTER CONTACT: GOLD PER ASTM B488
 ALL OTHER METAL PARTS: SILVER PER ASTM B-700
 8. CONTACT AND FERRULE SUPPLIED UNASSEMBLED.

REV	DESCRIPTION	BY DATE	APPD
K	REDRAWN ER18193	PSM 08/27/09	DCam

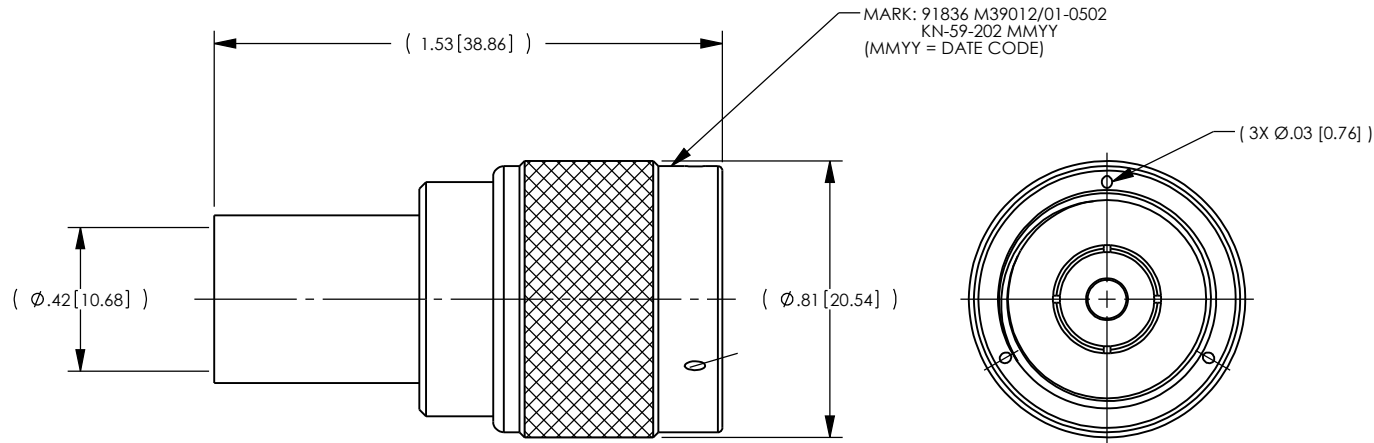

CATALOG P/N: KN-59-202

PER ASME Y14.5M-1994 UNLESS OTHERWISE SPECIFIED: DIMENSIONS ARE IN INCHES [MM] TOLERANCES: DECIMAL: .XX [X.X] \pm .01 [0.3] .XXX [X.XX] \pm .005 [0.13] .XXXX [X.XXX] \pm .XXX ANGLES: \pm 2° SCALE: 2:1				 by WINCHESTER		Winchester Electronics Corporation 62 Barnes Industrial Road North Wallingford, Connecticut 06492		
CUSTOMER SALES DRAWING				 THIRD ANGLE		N PLUG M39012/01-0502		
DRAWN	DATE	APPROVED	DATE	A	SDKN-59-202	SHT 1	OF 1	REV K
JL	05/17/74	LI	05/24/74					
APPROVED	DATE	APPROVED	DATE					
XXX	XX/XX/XX	XXX	XX/XX/XX					

DMF026 B

MAY 2007 THIS DRAWING BECAME THE PROPERTY OF PROPERTY OF WINCHESTER ELECTRONICS CORPORATION, WALLINGFORD, CT 06492