

High Reliability Rectangular Plastic Connector

The REP connector is a multi pole IP66 sealed rectangular plastic connector which provides a quick, reliable and easy connection in all electronic applications. The REP connectors range offers two main versions:

- Crimp termination contacts for **cable harness applications**,
- Straight or bent termination contacts for **PCB mount applications**.

Both versions are available in 3 layouts: 2, 6 and 12 ways and Hypertac can also delivered the connectors as a pre-cabled solution according to customers' specifications.

The REP connector series uses the proven Hypertac® Hyperboloid contact technology which guarantees excellent reliability, even under high levels of shocks and vibrations.

Other benefits:

- | | | |
|----------------------------------|----|--------------------------------------------------------------------------------------------------------------------------------------------------------------------------------|
| Compliance with standards | >> | UL 94, EN 61-373, EN 50-124, NF F 61-030, NF F 16-101, NF F 16-102 (fire & smoke), EN ISO 11925-2:2010, UNI CEI 11170-3, materials in polycarbonate and back shell in silicone |
| Cost saving | >> | Only one contact for cables from size 0.50mm ² to 2.5mm ² (14-12AWG) according to EN 50306-2 |
| Ease of use | >> | Polarised guides & 4 different configurations (cable to cable, clips, front and back panel mount) |
| Long life cycle | >> | 500 mating/unmating cycles: just push to mate, press & release to unmate |
| Sealing | >> | IP66. protection according to IEC/DIN EN 60529 |
| Reliability | >> | High current rating supporting up to 16A, high level of vibrations resistance (40G, 5 hours), high withstanding voltage up to 2725V |

Technical Characteristics

ELECTRICAL		MECHANICAL & MATERIAL	
Contacts	Ø 1.5mm (size 16)	Contact retention force	> 70 N
Withstanding voltage	2725V (EN-50124-1)	Mating cycles	> 500 cycles
Insulation resistance	≥ 5 x 10 ³ MΩ	Coding	3 configurations
Contact resistance	≤ 2.50 mΩ	Polarisation	180°
Voltage rating	230V (EN-50124-1) pollution degree 3 > 400V with plastic dummy contact	Weight (equipped with contacts)	2 ways: 17.3g 6 ways: 35.5g 12 ways: 62.8g
Current rating	16A	Insulator	Grey Thermoplastic (black for REP4--)
Contact plating	gold plating	Seal & grommet	Silicone
ENVIRONMENTAL			
Temperature range	-55° +110°C for REP 1-- & 2-- 250°C for REP 4--	Salt spray	> 96 hours (ASTM-B-117)
Vibration resistance	EN 61-373 cat. 2 (on boggie)	Environmental level	IP66 , IP67
Fire & Smoke	NF F 16-101: I2 F1 NF F 16-102: Exigence 4 EN ISO 11925-2: 30s UNI CEI 11170-3: Prospetto 2 UL 94: V0	Fluid resistance	Cleaning substances, gasoil, acid, basis, oxalic acid

Ordering Information

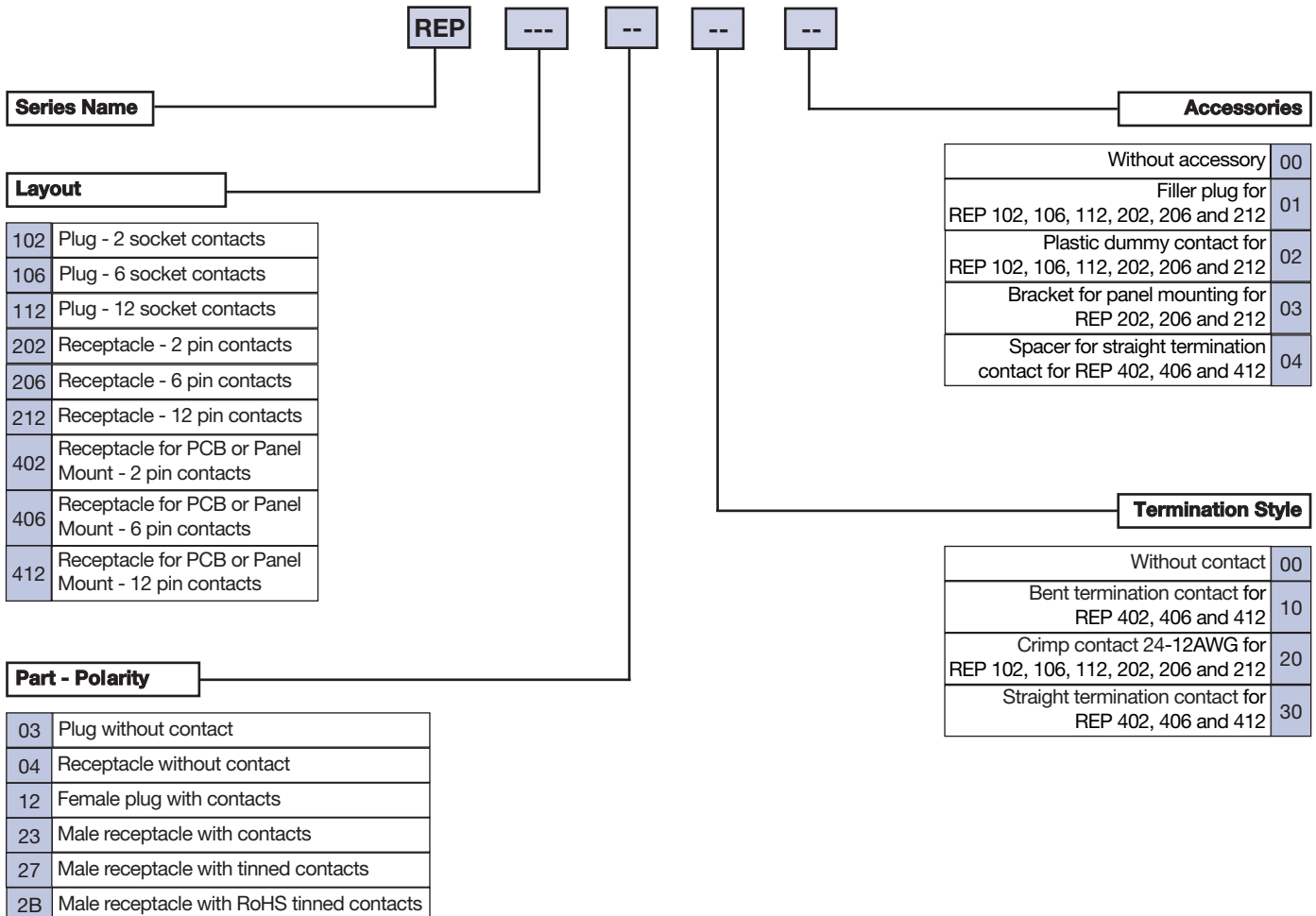

Drawings & Dimensions

Female Plug, Crimp Termination

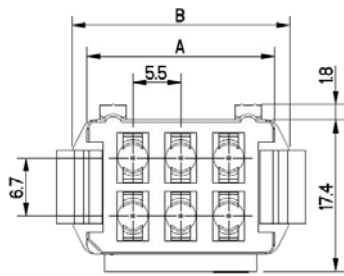
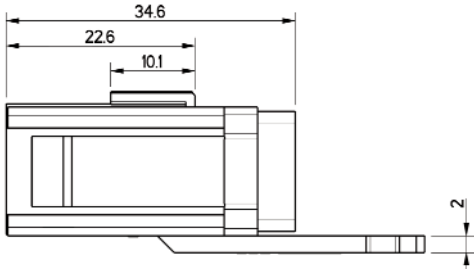

REP 1--	A	B
REP 102	10.5	14
REP 106	21.5	25
REP 112	38	41.5

Dimensions are in mm

Male Receptacle, Crimp Termination

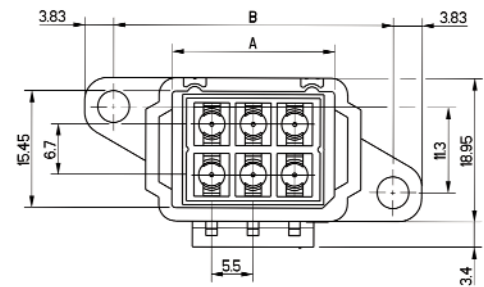
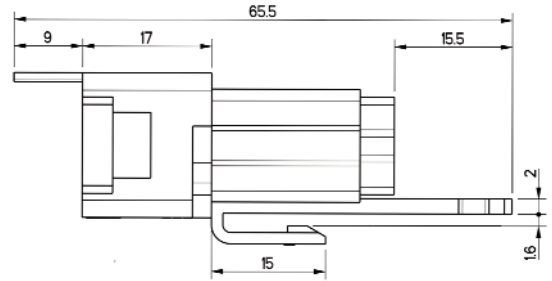

REP 2--	A	B
REP 202	10.65	26.1
REP 206	21.65	37.1
REP 212	38.15	53.6

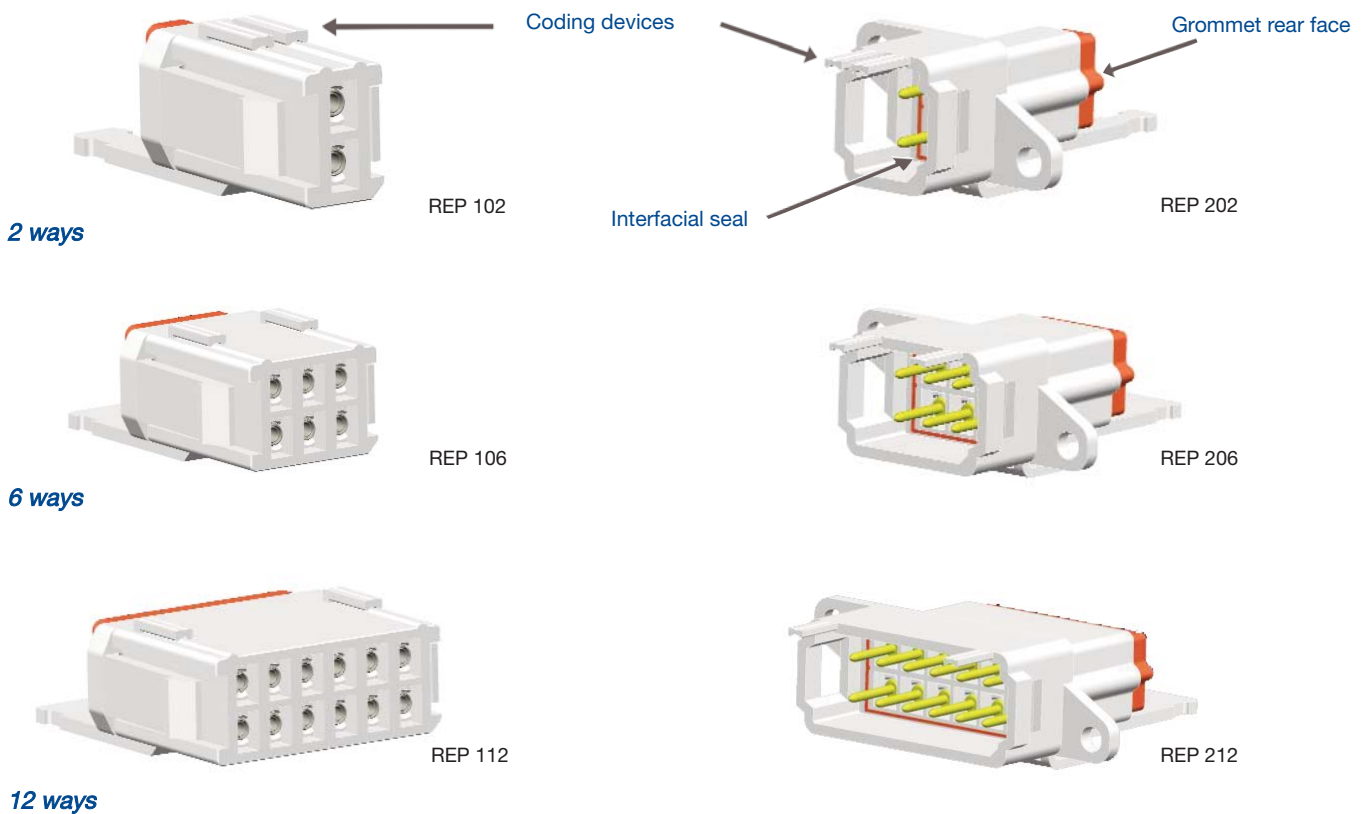

Drawings & Dimensions

Male Receptacle, Straight Termination

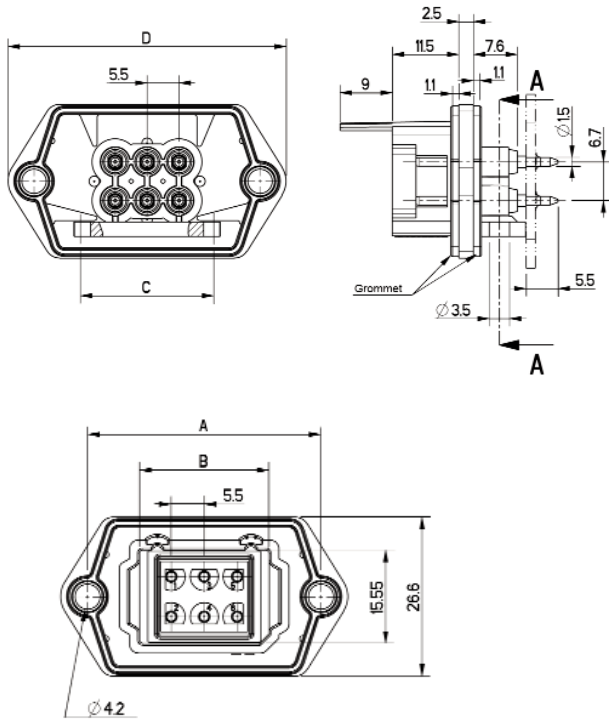

Male Receptacle, Bent Termination

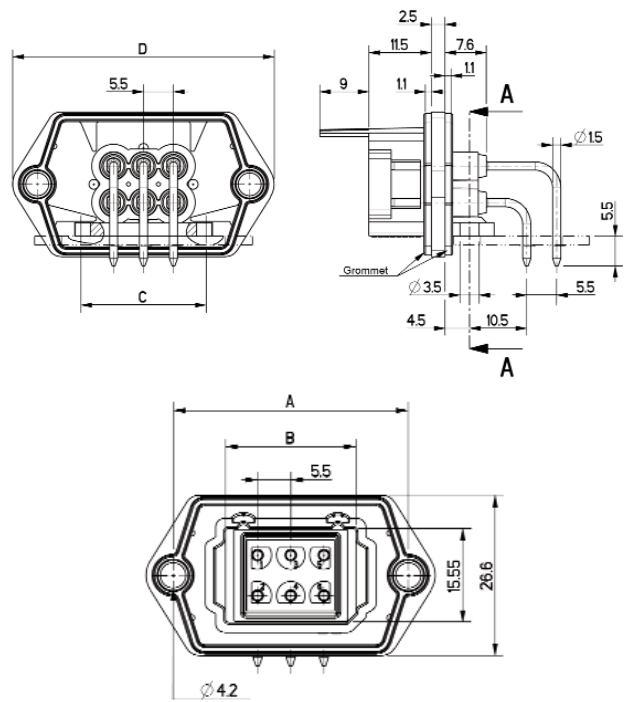

REP 4--	A	B	C	D
REP 402	28	10.65	12	37
REP 406	39	21.65	23	48
REP 412	55.5	38.15	39.5	64.5

Dimensions are in mm



2 ways



REP 402



6 ways



REP 406



12 ways

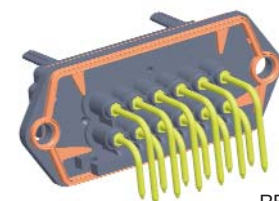
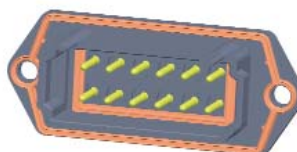

REP 412

Panel Mounting for REP 202, 206 and 212

Back Panel Mount

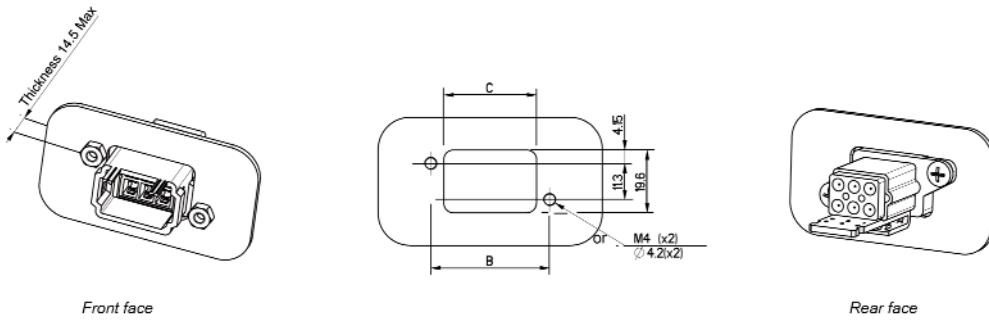

Front Panel Mount

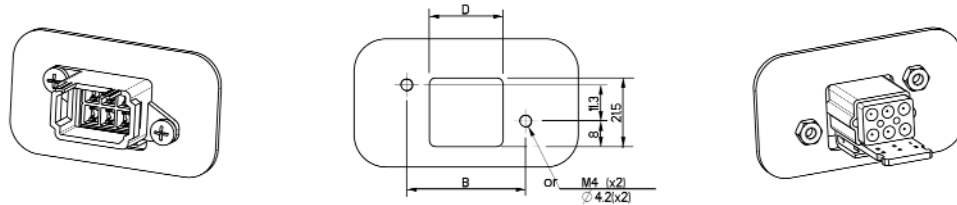

Panel Preparation detail with REP-003-xx accessory

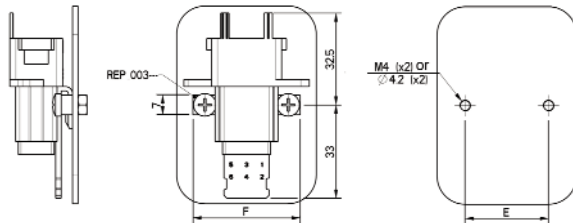

REP 2--	B	C	D	E	F
REP 202	26.1	18	12	18.7	27.2
REP 206	37.1	29	23	29.7	38.2
REP 212	53.6	45.5	39.5	46.2	54.7

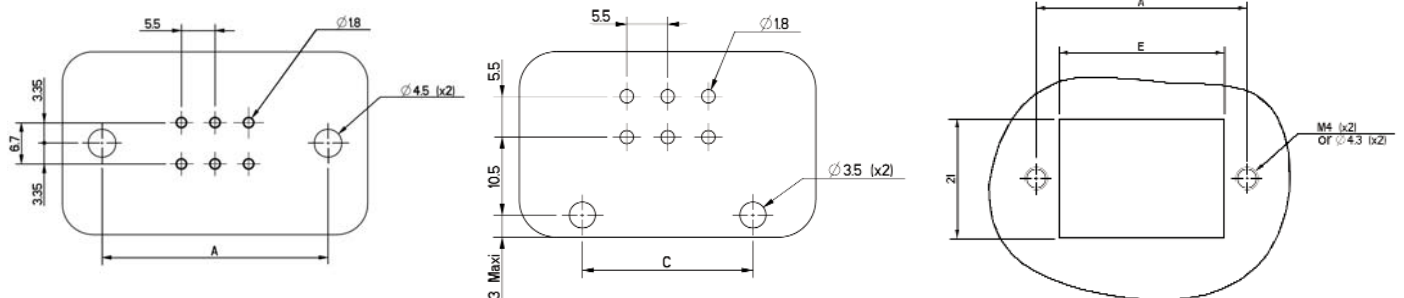
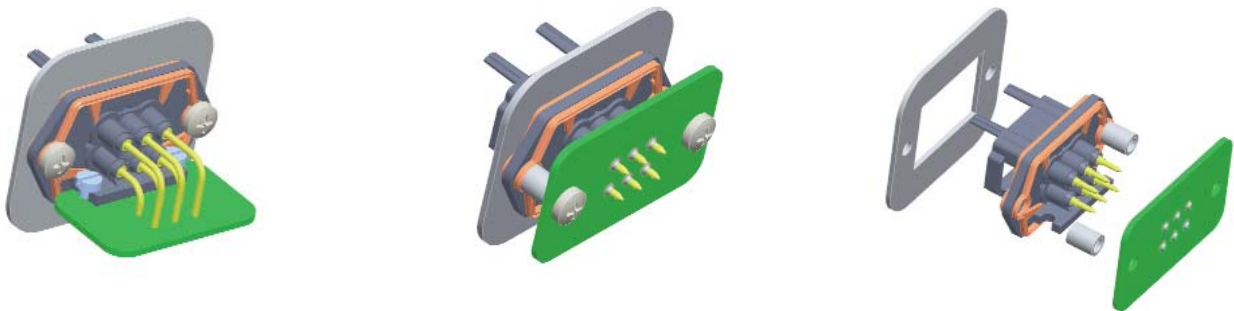

Panel Mounting for REP 402, 406 and 412



REP 4--	A	C	E
REP 402	28	12	18
REP 406	39	23	29
REP 412	55.5	39.5	45.5





PCB thickness <4mm

Contacts

Contacts			Crimping Tool			Extraction Tool
Part Number	Type	PIN dia. (size)	Crimping tool	Tool Turret	Position & Wire section	P/N
0151071-20-OG*	Pin 	1.5mm (16)	Astro-tool TGV 101 or Daniels FT8	TGV 202 red or SH 463 red	4 - 0.25 to 0.34mm ² (23AWG) 4 - 0.50mm ² to 0.60mm ² (20AWG) 5 - 0.50mm ² to 1mm ² (18AWG) 6 - 1.34mm ² to 1.50mm ² (16AWG) 7 - 1.82mm ² to 2.61mm ² (14-12AWG)	SD-015000012
0151832-20-N1*	Socket 					

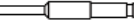
* Crimp contacts for layout 102, 106, 112, 202, 206, 212.

Accessories

Part Number	Description
REP_001	 Filler plug
REP_002	 Plastic dummy contact to use > 400V
REP_003-02	 Bracket for panel mounting, 2 way connector
REP_003-06	 Bracket for panel mounting, 6 way connector
REP_003-12	 Bracket for panel mounting, 12 way connector
REP_004	 Spacer for straight termination contact

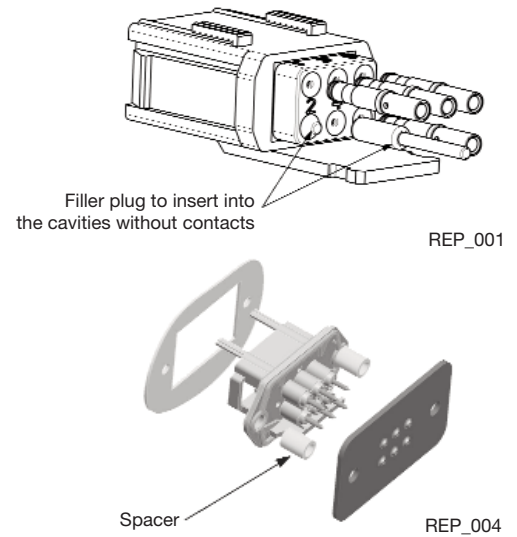

Main Applications



Industry



Railway



Truck



Test & Measurement



Marine

REP series is covering



Automotive



Civil Avionics



Public Work Equipment

More information on our website www.hypertac.com