

### ADVANCE PRODUCT INFORMATION

#### FEATURES

- Low Power (<10mA)
- Single +5V Operation
- Crystal Driven Clock Recovery
- Data Rates from < 64kbit/s to 10Mbit/s
- Accepts Manchester or AMI Data Format
- Dual ALBO Ports Allow >60dB Dynamic Range
- Built-In Analog Jitter Attenuator
- On-Chip Loop-Back
- Independent Transmit and Receive Functions
- On-Chip Zero Suppression, B8ZS/HDB3
- Bipolar Violation Alarm
- Loss of Carrier Alarm

#### GENERAL DESCRIPTION

The LIU-02 is a high performance serial data transceiver that is capable of transmitting as well as receiving over a wide range of serial data formats, including T1 (1.544Mbit/s), T148 (2.048Mbit/s), T1C (3.152Mbit/s), T2 (6.312Mbit/s) and 8.448Mbit/s standards. It is also usable at the ISDN basic data rate of 64kbit/s as well as LAN data rates up to 10Mbit/s.

A crystal driven phase-locked type oscillator provides reliable clock recovery and ease of use. The receiver contains a wide bandwidth, low noise preamplifier that can work with signal dynamic range of up to 60dB. With appropriate line equalization, the LIU-02 can accurately recover data that has been transmitted over 6,000 feet (2,000 meters) at 1.544Mbit/s data rate.

The LIU-02 contains a transmitter with built-in line drivers. It normally accepts NRZ data input from a host system with the data transfer timed by the on-board crystal oscillator. However, a loop-back control feature allows the received data to be inter-

nally connected directly to the transmitter timed by the recovered clock. A standard zero substitution, B8ZS or HDB3, is automatically performed on all incoming and outgoing data. The LIU-02 also provides an alarm output anytime a bipolar violation is received not corresponding to the zero suppression standards. Similarly, the ALBO circuit will issue an alarm whenever there is insufficient signal strength.

#### ORDERING INFORMATION †

PACKAGE		OPERATING TEMPERATURE RANGE
CERDIP	PLASTIC	
LIU02FW	LIU02FP	XIND
—	LIU02FS††	XIND

† Burn-in is available on commercial and industrial temperature range parts in CerDIP, plastic DIP, and TO-can packages. For ordering information, see PMI's Data Book Section 2.

†† For availability and burn-in information on SO and PLCC packages, contact your local sales office.

#### PIN CONNECTIONS

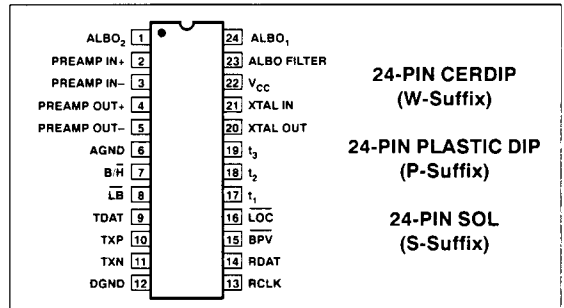

#### FUNCTIONAL BLOCK DIAGRAM

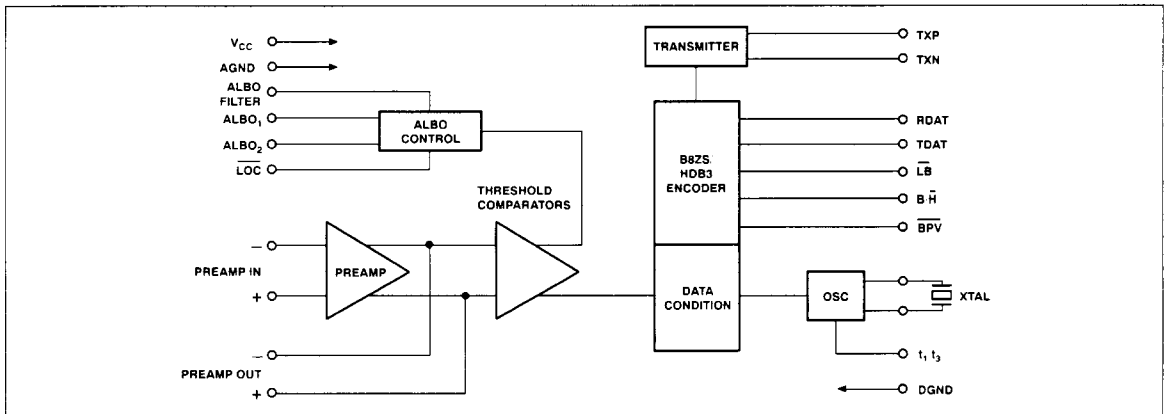

This advance product information describes a product in development at the time of this printing. Final specifications may vary. Please contact local sales office or distributor for final data sheet.

**ABSOLUTE MAXIMUM RATINGS**

Maximum Voltage, Pin 3 to Pin 11 .....	6.5V, -0.5V
Maximum Voltage, Any Pin Except 12 and 13 .....	$V_{CC}$
Maximum Sinking Current, Any Pin .....	20mA
Operating Temperature Range .....	-40°C to +85°C
Storage Temperature Range .....	-65°C to +150°C
Lead Soldering Temperature .....	300°C
Junction Temperature .....	150°C

PACKAGE TYPE	$\theta_{JA}$ (Note 1)	$\theta_{JC}$	UNITS
24-Pin Hermetic DIP (W)	69	10	°C/W
24-Pin Plastic DIP (P)	62	32	°C/W
24-Pin SOL (S)	72	24	°C/W

**NOTE:**

1.  $\theta_{JA}$  is specified for worst case mounting conditions, i.e.,  $\theta_{JA}$  is specified for device in socket for CerDIP and P-DIP packages;  $\theta_{JA}$  is specified for device soldered to printed circuit board for SOL package.

**ELECTRICAL CHARACTERISTICS** at  $V_{CC} = 5V$ ,  $-40^\circ C \leq T_A \leq +85^\circ C$ , unless otherwise noted.

PARAMETER	SYMBOL	CONDITIONS	LIU-02 TYP	UNITS
<b>SUPPLY</b>				
Supply Voltage	$V_{CC}$		5.0	V
Supply Current	$I_{CC}$		10	mA
<b>PREAMPLIFIER</b>				
Preamplifier Open-Loop Gain	$A_O$		56	dB
Preamplifier Bandwidth	$B_W$	-3dB	10	MHz
Input Offset Voltage	$V_{OS}$		5	mV
Output High Swing	$V_{OHA}$		4	V
Output Low Swing	$V_{OLA}$		1.2	V
Output Impedance	$Z_{OUT}$		50	$\Omega$
Output Self Bias Voltage	$V_{DC}$		2.6	V
<b>TRANSMITTER</b>				
Output Drive Current	$I_{OT}$	Sinking	30	mA
Output Low Voltage	$V_{OL}$	$I_O = 30mA$	0.4	V
Output Fall Time	$T_{OF}$	$I_O = 30mA$	20	ns
<b>CLOCK CIRCUIT</b>				
Maximum Clock Frequency			20	MHz
RCLK Duty Cycle			50	%
<b>DIGITAL CHARACTERISTICS</b>				
High Level Input Voltage	$V_{IN}$		2.0	V MIN
Low Level Input Voltage	$V_{IL}$		0.8	V MAX
High Level Output Voltage	$V_{OHD}$		3.5	V MIN
Low Level Output Voltage	$V_{OLD}$		0.4	V MAX
Input Leakage Current	$I_{ID}$		$\pm 10$	$\mu A$
RDAT Output Pulse Width	$P_{WD}$	$f = 1.544MHz$	648	ns
RCLK Output Pulse Width	$P_{WC}$	$f = 1.544MHz$	324	ns
<b>ALBO</b>				
ALBO Threshold	$V_{TA}$		1.6	V
Threshold Tolerance			$\pm 10$	%
ALBO ON Resistance	$R_{D\_MIN}$		10	$\Omega$
ALBO OFF Resistance	$R_{D\_MAX}$		20	k $\Omega$
<b>DATA/CLOCK THRESHOLD</b>				
Data Threshold	$V_{TD}\%$		50	%
Clock Threshold	$V_{TC}\%$		50	%