

CIRCUIT SIZE	DIM. "A"	DIM. "B"
6	.54 (13.8)	.33 (8.4)
8	.71 (18.0)	.50 (12.6)
10	.87 (22.2)	.66 (16.8)
12	1.04 (26.4)	.83 (21.0)
14	1.20 (30.6)	.99 (25.2)
16	1.37 (34.8)	1.16 (29.4)
18	1.54 (39.0)	1.32 (33.6)
20	1.70 (43.2)	1.49 (37.8)
22	1.87 (47.4)	1.65 (42.0)
24	2.03 (51.6)	1.82 (46.2)

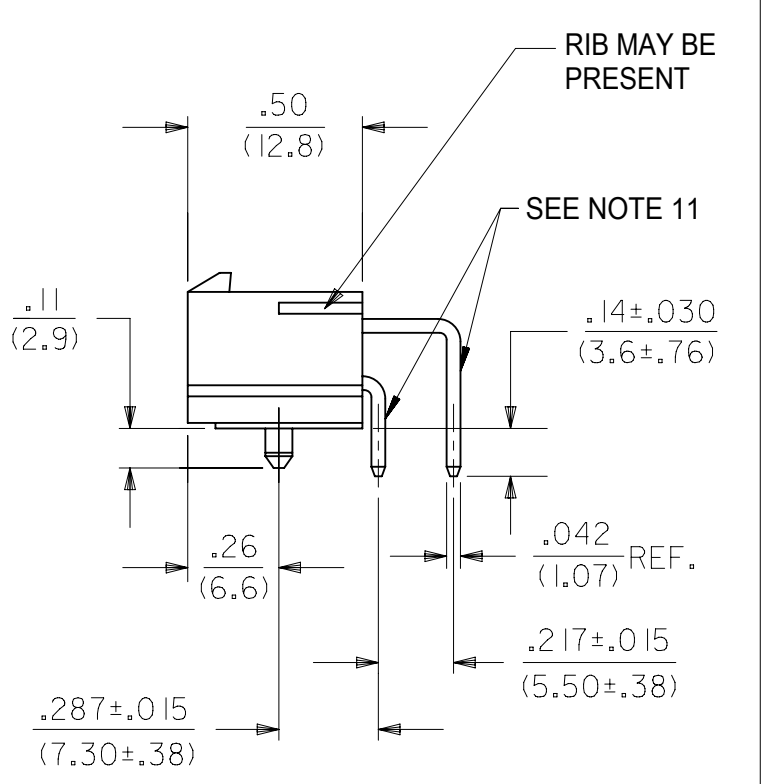

DIMENSIONS TYPICAL FOR ALL CIRCUIT SIZES

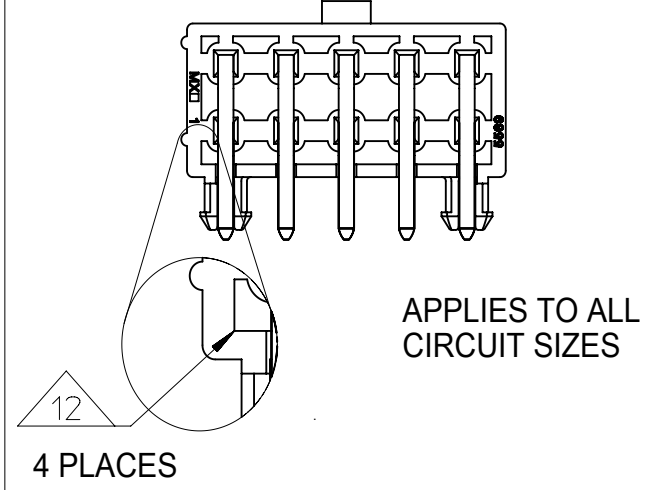

- NOTES:**
- 1) MATERIAL:  
HOUSING:  
"BLANK" = NYLON (PA66), LOW HALOGEN, UNFILLED, UL94V-2, COLOR: NATURAL  
"BL" = NYLON (PA66), LOW HALOGEN, UNFILLED, UL94V-2, COLOR: BLACK  
"210" = NYLON (PA66), LOW HALOGEN, UNFILLED, UL94V-0, COLOR: NATURAL  
"400" = NYLON (PA66), LOW HALOGEN, UNFILLED, UL94V-0, COLOR: BLACK  
TERMINAL:  
BRASS ALLOY
- 2) FINISH (PLATING):  
G, GS = .000030/(0.00076) MIN. SELECT GOLD OVER .000100/(0.00254) MIN. SELECT MATTE TIN OVER .000050/(0.00127) MIN. NICKEL OVERALL  
GS2 = .000015/(0.00038) MIN. SELECT GOLD OVER .000100/(0.00254) MIN. SELECT MATTE TIN OVER .000050/(0.00127) MIN. NICKEL OVERALL  
GS3 = .000050/(0.00127) MIN. SELECT GOLD OVER .000100/(0.00254) MIN. SELECT MATTE TIN OVER .000050/(0.00127) MIN. NICKEL OVERALL  
BLANK, S, MS = .000100/(0.00254) MIN. MATTE TIN OVER .000050/(0.00127) MIN. NICKEL OVERALL  
RM = .000060/(0.00152) MIN. REFLOWED MATTE TIN OVER .000050/(0.00127) MIN. NICKEL OVERALL
- 3) PRODUCT SPECIFICATION: PS-5556-001
- 4) PACKAGING:  
"BLANK" = BULK PACKED PER PK-5569-002 (NOT RECOMMENDED DUE TO SHIPPING AND HANDLING DAMAGE).  
"T" = TRAY PACKED PER PK-5569-003 (RECOMMENDED FOR NEW APPLICATIONS)
- 5) PART MATES WITH MINI-FIT JR. RECEPTACLE SERIES 5557.
- 6) MOUNTING OPTIONS:  
1 = SCREW MOUNT (SEE SD-5569-NA\* SERIES DRAWING)  
2 = PEG MOUNT
- 7) DISCOLORATION IN THE BANDOLIER CARRIER AREA OF THE PIN IS INHERENT TO THE PLATING PROCESS AND IS DUE TO THE MASKING EFFECT OF THE CARRIER. THIS DISCOLORATION IS IN A NON-FUNCTIONAL AREA OF THE PIN AND WILL NOT AFFECT THE PERFORMANCE OF THE HEADER ASSEMBLY.
- 8) PART CONFORMS TO CLASS "B" REQUIREMENTS OF COSMETIC SPECIFICATION PS-45499-002.
- 9) CONNECTORS ARE NOT TO BE MATED AND UNMATED WHILE CIRCUITS ARE LIVE.
- 10) PARTS ARE NOT DESIGNED FOR CURRENT SHARING.
- 11) FORMING MARKS ON PINS ARE ACCEPTABLE.
- 12) CORNER CORE-OUTS ARE OPTIONAL AND MAY OR MAY NOT BE PRESENT.

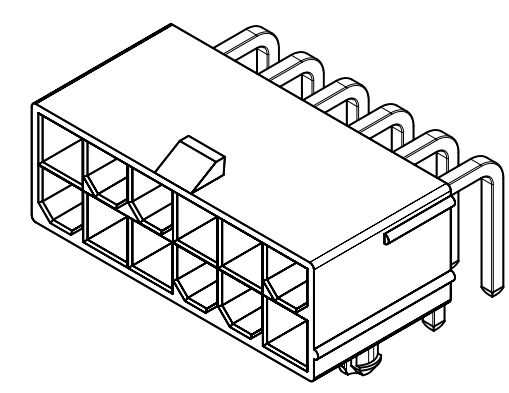
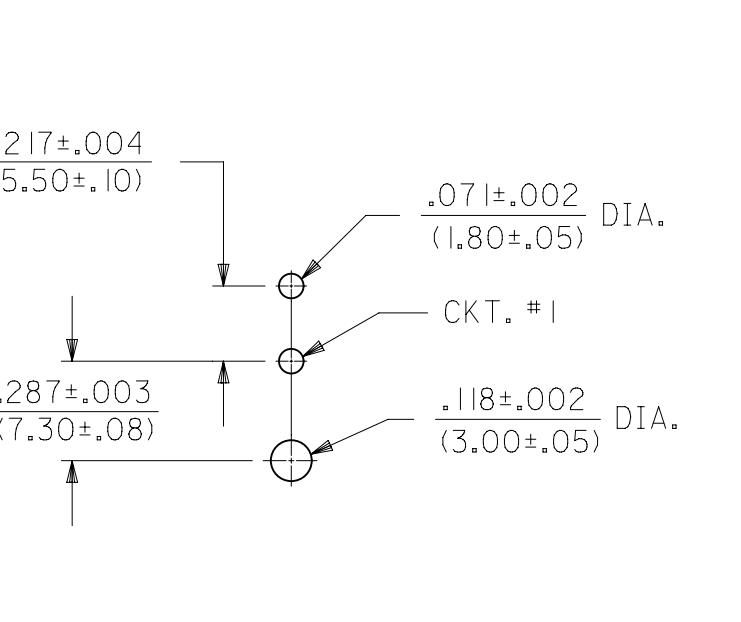
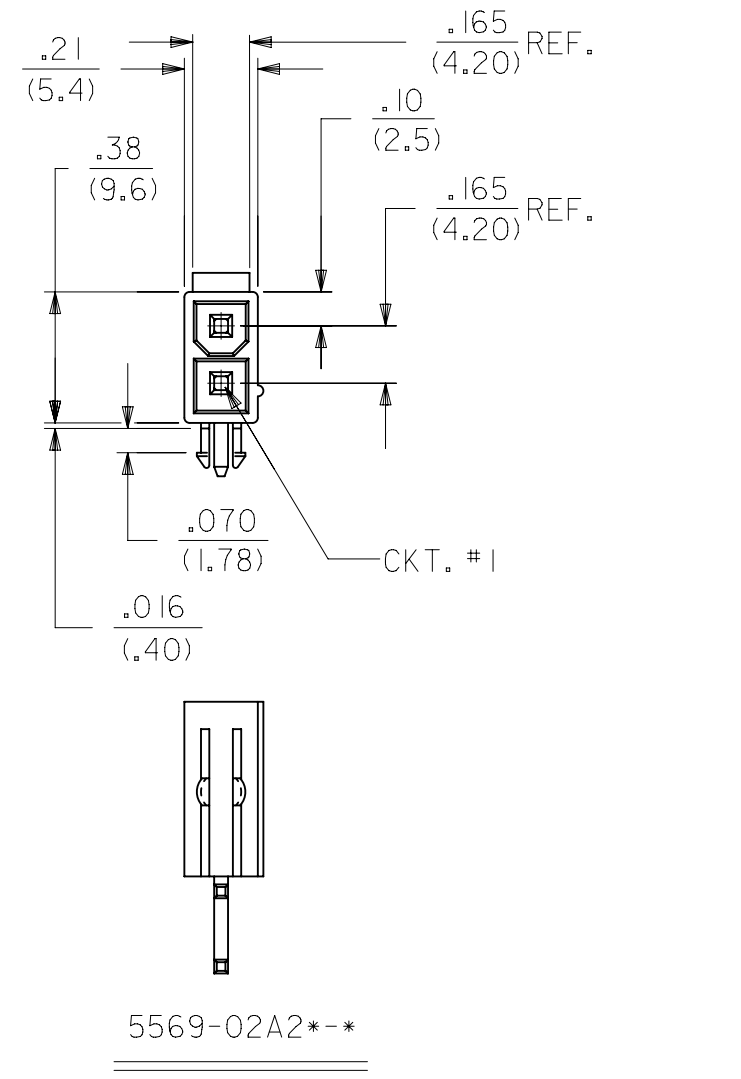
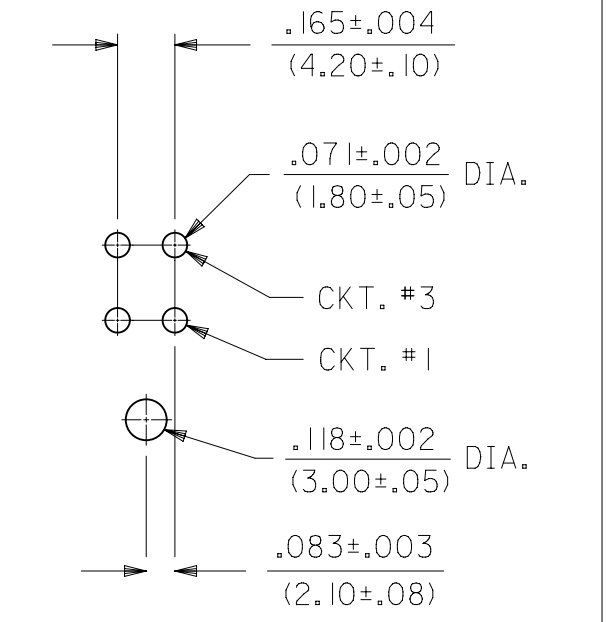
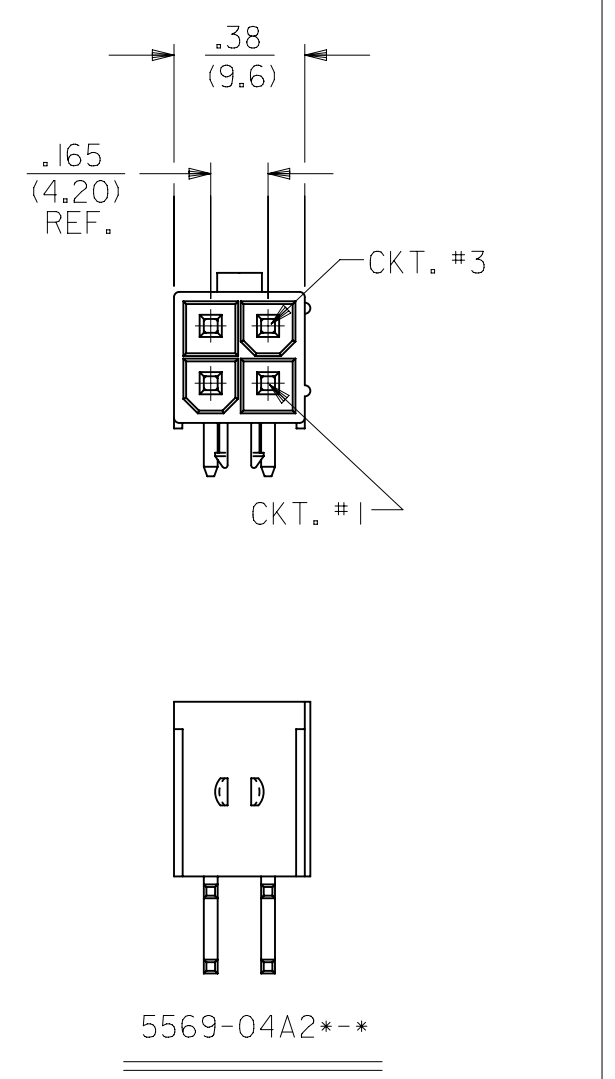
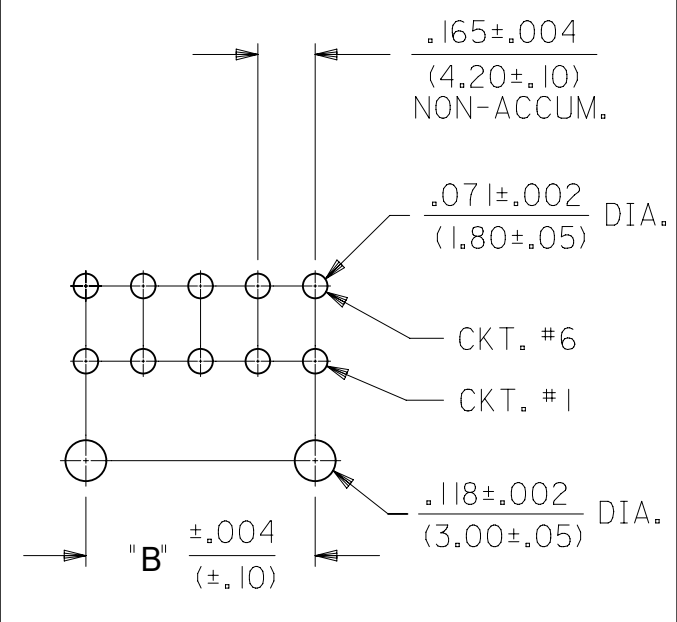
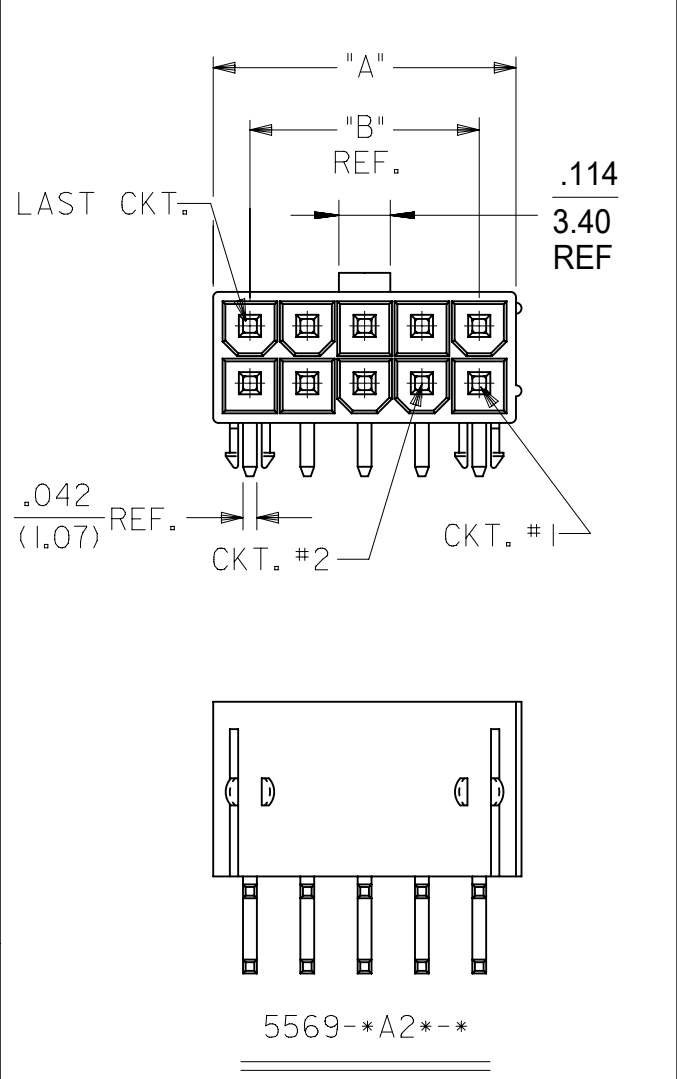

SYMBOLS										THIS DRAWING CONTAINS INFORMATION THAT IS PROPRIETARY TO MOLEX ELECTRONIC TECHNOLOGIES, LLC AND SHOULD NOT BE USED WITHOUT WRITTEN PERMISSION									
DIMENSION UNITS					SCALE					CURRENT REV DESC: MIGRATE TO ECTR									
IN/MM					4:1					EC NO: 172489 DRWN: ANESSER 2018/01/26 CHK'D: JBELL 2018/02/20 APPR: FSMITH 2018/02/22 INITIAL REVISION: DRWN: RJF 1988/02/16 APPR: FSMITH 2016/12/20									
GENERAL TOLERANCES (UNLESS SPECIFIED)																			
4 PLACES		±		±		MM		INCH		PRODUCT CUSTOMER DRAWING DOCUMENT NUMBER: 55690002-SD DOC TYPE: PSD DOC PART: 000 REVISION: A MATERIAL NUMBER: SEE CHART CUSTOMER: GENERAL MARKET SHEET NUMBER: 1 OF 4									
3 PLACES		±		±		0.01													
2 PLACES		±		0.25		±		0.015											
1 PLACE		±		0.38		±													
0 PLACES		±		±															
ANGULAR TOL					± 0.5 °					THIRD ANGLE PROJECTION									
DRAFT WHERE APPLICABLE MUST REMAIN WITHIN DIMENSIONS										DRAWING SERIES: C-SIZE 5569									

BULK PACKAGED PER PK-5569-002													
THESE PART NUMBERS ARE NOT RECOMMENDED, FOR NEW APPLICATIONS USE THE TRAY PACKED PART NUMBERS													
PART NUMBER	ENG. NUMBER	CKT. SIZE	PLATING (NOTE 2)	HSG MAT'L	PART NUMBER	ENG. NUMBER	CKT. SIZE	PLATING (NOTE 2)	HSG MAT'L				
39-30-1020	5569-02A2	2	MATTE TIN OVER NICKEL SEE NOTE 2 OPTION "BLANK"	94V-2	39-30-0020	5569-02A2-210	2	MATTE TIN OVER NICKEL SEE NOTE 2 OPTION "BLANK"	94V-0				
39-30-1040	5569-04A2	4			39-30-0040	5569-04A2-210	4						
39-30-1060	5569-06A2	6			39-30-0060	5569-06A2-210	6						
39-30-1080	5569-08A2	8			39-30-0080	5569-08A2-210	8						
39-30-1100	5569-10A2	10			39-30-0100	5569-10A2-210	10						
39-30-1120	5569-12A2	12			39-30-0120	5569-12A2-210	12						
39-30-1140	5569-14A2	14			39-30-0140	5569-14A2-210	14						
39-30-1160	5569-16A2	16			39-30-0160	5569-16A2-210	16						
39-30-1180	5569-18A2	18			39-30-0180	5569-18A2-210	18						
39-30-1200	5569-20A2	20			39-30-0200	5569-20A2-210	20						
39-30-1220	5569-22A2	22			39-30-0220	5569-22A2-210	22						
39-30-1240	5569-24A2	24			39-30-0240	5569-24A2-210	24						
39-30-1021	5569-02A2G	2			30 μ" SELECT GOLD SEE NOTE 2 OPTION "G"	94V-2	39-30-1022			5569-02A2G-210	2	30 μ" SELECT GOLD SEE NOTE 2 OPTION "G"	94V-0
39-30-1041	5569-04A2G	4					39-30-1042			5569-04A2G-210	4		
39-30-1061	5569-06A2G	6	39-30-1062	5569-06A2G-210			6						
39-30-1081	5569-08A2G	8	39-30-1082	5569-08A2G-210			8						
39-30-1101	5569-10A2G	10	39-30-1102	5569-10A2G-210			10						
39-30-1121	5569-12A2G	12	39-30-1122	5569-12A2G-210			12						
39-30-1141	5569-14A2G	14	39-30-1142	5569-14A2G-210			14						
39-30-1161	5569-16A2G	16	39-30-1162	5569-16A2G-210			16						
39-30-1181	5569-18A2G	18	39-30-1182	5569-18A2G-210			18						
39-30-1201	5569-20A2G	20	39-30-1202	5569-20A2G-210			20						
NOT ASSIGNED	5569-22A2G	22	39-30-1222	5569-22A2G-210			22						
39-30-1241	5569-24A2G	24	39-30-1242	5569-24A2G-210			24						

SYMBOLS	THIS DRAWING CONTAINS INFORMATION THAT IS PROPRIETARY TO MOLEX ELECTRONIC TECHNOLOGIES, LLC AND SHOULD NOT BE USED WITHOUT WRITTEN PERMISSION													
	DIMENSION UNITS		SCALE		CURRENT REV DESC: MIGRATE TO ECTR									
	IN/MM		1:1		<b>molex</b> MINI-FIT JR RIGHT ANGLE HEADER ASSEMBLIES WITH MOUNTING PEGS PRODUCT CUSTOMER DRAWING									
	GENERAL TOLERANCES (UNLESS SPECIFIED)										EC NO: 172489		2018/01/26	
	MM		INCH								DRWN: ANESSER		2018/02/20	
	4 PLACES ±		±		CHK'D: JBELL		2018/02/22		APPR: FSMITH					
	3 PLACES ±		± 0.01		INITIAL REVISION:									
	2 PLACES ±		± 0.015		DRWN: RJF		1988/02/16		DOCUMENT NUMBER					
	1 PLACE ±		±		APPR: FSMITH		2016/12/20		55690002-SD					
	0 PLACES ±		±		THIRD ANGLE PROJECTION		DRAWING		DOC TYPE					
ANGULAR TOL ± 0.5 °		DRAFT WHERE APPLICABLE MUST REMAIN WITHIN DIMENSIONS		C-SIZE		SERIES		DOC PART						
REVISION		SHEET NUMBER		MATERIAL NUMBER		CUSTOMER		REVISION						
A		2 OF 4		SEE CHART		GENERAL MARKET		A						

DOCUMENT STATUS	P1	RELEASE DATE	2018/02/22 21:31:14
-----------------	----	--------------	---------------------

THIS DRAWING REPLACES DRAWING SDA-5569-NA2\*~\*

TRAY PACKAGED PER PK-5569-003

PART NUMBER	ENG. NUMBER	CKT. SIZE	PLATING (NOTE 2)	HSG MAT'L	PART NUMBER	ENG. NUMBER	CKT. SIZE	PLATING (NOTE 2)	HSG MAT'L
26-01-3127	5569-02A2GS2-210-T	2	15 μ" SELECT GOLD SEE NOTE 2 OPTION "GS2"	94V-0	46999-0013	5569-02A2S-400-T	2	MATTE TIN OVER NICKEL SEE NOTE 2 OPTION "S"	BLACK 94V-0
26-01-3128	5569-04A2GS2-210-T	4			46999-0014	5569-04A2S-400-T	4		
NOT TOOLED	5569-06A2GS2-210-T	6			46999-0015	5569-06A2S-400-T	6		
NOT TOOLED	5569-08A2GS2-210-T	8			46999-0016	5569-08A2S-400-T	8		
NOT TOOLED	5569-10A2GS2-210-T	10			46999-0017	5569-10A2S-400-T	10		
NOT TOOLED	5569-12A2GS2-210-T	12			46999-0018	5569-12A2S-400-T	12		
NOT TOOLED	5569-14A2GS2-210-T	14			46999-0019	5569-14A2S-400-T	14		
NOT TOOLED	5569-16A2GS2-210-T	16			46999-0020	5569-16A2S-400-T	16		
NOT TOOLED	5569-18A2GS2-210-T	18			46999-0021	5569-18A2S-400-T	18		
NOT TOOLED	5569-20A2GS2-210-T	20			46999-0022	5569-20A2S-400-T	20		
NOT TOOLED	5569-22A2GS2-210-T	22			46999-0023	5569-22A2S-400-T	22		
NOT TOOLED	5569-24A2GS2-210-T	24			46999-0024	5569-24A2S-400-T	24		
26-01-3141	5569-02A2GS3-T	2	50 μ" SELECT GOLD SEE NOTE 2 OPTION "GS3"	94V-2	46999-0538	5569-02A2GS2-400-T	2	15 μ" SELECT GOLD SEE NOTE 2 OPTION "GS2"	BLACK 94V-0
26-01-3142	5569-04A2GS3-T	4			46999-0539	5569-04A2GS2-400-T	4		
26-01-3143	5569-06A2GS3-T	6			46999-0540	5569-06A2GS2-400-T	6		
26-01-3144	5569-08A2GS3-T	8			46999-0541	5569-08A2GS2-400-T	8		
NOT TOOLED	5569-10A2GS3-T	10			46999-0542	5569-10A2GS2-400-T	10		
NOT TOOLED	5569-12A2GS3-T	12			46999-0543	5569-12A2GS2-400-T	12		
NOT TOOLED	5569-14A2GS3-T	14			46999-0544	5569-14A2GS2-400-T	14		
26-01-3148	5569-16A2GS3-T	16			46999-0545	5569-16A2GS2-400-T	16		
NOT TOOLED	5569-18A2GS3-T	18			46999-0546	5569-18A2GS2-400-T	18		
NOT TOOLED	5569-20A2GS3-T	20			46999-0547	5569-20A2GS2-400-T	20		
NOT TOOLED	5569-22A2GS3-T	22			46999-0548	5569-22A2GS2-400-T	22		
NOT TOOLED	5569-24A2GS3-T	24			46999-0549	5569-24A2GS2-400-T	24		
46999-0001	5569-02A2S-BL-T	2	MATTE TIN OVER NICKEL SEE NOTE 2 OPTION "S"	BLACK 94V-2	46999-0515	5569-02A2G-400-T	2	30 μ" SELECT GOLD SEE NOTE 2 OPTION "G"	BLACK 94V-0
46999-0002	5569-04A2S-BL-T	4			46999-0516	5569-04A2G-400-T	4		
46999-0003	5569-06A2S-BL-T	6			46999-0517	5569-06A2G-400-T	6		
46999-0004	5569-08A2S-BL-T	8			46999-0518	5569-08A2G-400-T	8		
46999-0005	5569-10A2S-BL-T	10			46999-0519	5569-10A2G-400-T	10		
46999-0006	5569-12A2S-BL-T	12			46999-0520	5569-12A2G-400-T	12		
46999-0007	5569-14A2S-BL-T	14			46999-0521	5569-14A2G-400-T	14		
46999-0008	5569-16A2S-BL-T	16			46999-0522	5569-16A2G-400-T	16		
46999-0009	5569-18A2S-BL-T	18			46999-0523	5569-18A2G-400-T	18		
46999-0010	5569-20A2S-BL-T	20			46999-0524	5569-20A2G-400-T	20		
46999-0011	5569-22A2S-BL-T	22			46999-0525	5569-22A2G-400-T	22		
46999-0012	5569-24A2S-BL-T	24			46999-0526	5569-24A2G-400-T	24		

SYMBOLS										THIS DRAWING CONTAINS INFORMATION THAT IS PROPRIETARY TO MOLEX ELECTRONIC TECHNOLOGIES, LLC AND SHOULD NOT BE USED WITHOUT WRITTEN PERMISSION									
DIMENSION UNITS					SCALE					CURRENT REV DESC: MIGRATE TO ECTR									
IN/MM					1:1					EC NO: 172489 DRWN: ANESSER 2018/01/26 CHK'D: JBELL 2018/02/20 APPR: FSMITH 2018/02/22 INITIAL REVISION: DRWN: RJF 1988/02/16 APPR: FSMITH 2016/12/20									
GENERAL TOLERANCES (UNLESS SPECIFIED)																			
4 PLACES ±					MM					INCH					PRODUCT CUSTOMER DRAWING DOCUMENT NUMBER: 55690002-SD DOC TYPE: PSD DOC PART: 000 REVISION: A MATERIAL NUMBER: SEE CHART CUSTOMER: GENERAL MARKET SHEET NUMBER: 3 OF 4				
3 PLACES ±					± 0.01														
2 PLACES ±					± 0.25 ± 0.015														
1 PLACE ±					± 0.38 ±														
0 PLACES ±					±														
ANGULAR TOL ± 0.5 °										THIRD ANGLE PROJECTION					DRAWING SERIES: C-SIZE 5569				
DRAFT WHERE APPLICABLE MUST REMAIN WITHIN DIMENSIONS										SEE CHART									

THIS DRAWING REPLACES DRAWING SDA-5569-NA2\*.\*

DOCUMENT STATUS P1 RELEASE DATE 2018/02/22 21:31:14

TRAY PACKAGED PER PK-5569-003

PART NUMBER	ENG. NUMBER	CKT. SIZE	PLATING (NOTE 2)	HSG MAT'L	PART NUMBER	ENG. NUMBER	CKT. SIZE	PLATING (NOTE 2)	HSG MAT'L	PART NUMBER	ENG. NUMBER	CKT. SIZE	PLATING (NOTE 2)	HSG MAT'L						
50-36-1757	5569-02A2S-T	2	MATTE TIN OVER NICKEL SEE NOTE 2 OPTION "S"	94V-2	50-36-1758	5569-02A2S-210-T	2	MATTE TIN OVER NICKEL SEE NOTE 2 OPTION "S"	94V-0	26-01-3114	5569-02A2GS2-T	2	15 μ" SELECT GOLD SEE NOTE 2 OPTION "GS2"	94V-2						
50-36-1767	5569-04A2S-T	4			50-36-1768	5569-04A2S-210-T	4			26-01-3115	5569-04A2GS2-T	4								
50-36-1777	5569-06A2S-T	6			50-36-1778	5569-06A2S-210-T	6			26-01-3116	5569-06A2GS2-T	6								
50-36-1787	5569-08A2S-T	8			50-36-1788	5569-08A2S-210-T	8			NOT TOOLED	5569-08A2GS2-T	8								
50-36-1797	5569-10A2S-T	10			50-36-1798	5569-10A2S-210-T	10			NOT TOOLED	5569-10A2GS2-T	10								
50-36-1807	5569-12A2S-T	12			50-36-1808	5569-12A2S-210-T	12			26-01-3119	5569-12A2GS2-T	12								
50-36-1817	5569-14A2S-T	14			50-36-1818	5569-14A2S-210-T	14			NOT TOOLED	5569-14A2GS2-T	14								
50-36-1827	5569-16A2S-T	16			50-36-1828	5569-16A2S-210-T	16			NOT TOOLED	5569-16A2GS2-T	16								
50-36-1837	5569-18A2S-T	18			50-36-1838	5569-18A2S-210-T	18			NOT TOOLED	5569-18A2GS2-T	18								
50-36-1847	5569-20A2S-T	20			50-36-1848	5569-20A2S-210-T	20			NOT TOOLED	5569-20A2GS2-T	20								
50-36-1857	5569-22A2S-T	22			50-36-1858	5569-22A2S-210-T	22			NOT TOOLED	5569-22A2GS2-T	22								
50-36-1867	5569-24A2S-T	24			50-36-1868	5569-24A2S-210-T	24			26-01-3126	5569-24A2GS2-T	24								
50-36-1755	5569-02A2GS-T	2			30 μ" SELECT GOLD SEE NOTE 2 OPTION "GS"	94V-2	50-36-1756			5569-02A2GS-210-T	2	30 μ" SELECT GOLD SEE NOTE 2 OPTION "GS"			94V-0					
50-36-1765	5569-04A2GS-T	4					50-36-1766			5569-04A2GS-210-T	4									
50-36-1775	5569-06A2GS-T	6	50-36-1776	5569-06A2GS-210-T			6													
50-36-1785	5569-08A2GS-T	8	50-36-1786	5569-08A2GS-210-T			8													
50-36-1795	5569-10A2GS-T	10	50-36-1796	5569-10A2GS-210-T			10													
50-36-1805	5569-12A2GS-T	12	50-36-1806	5569-12A2GS-210-T			12													
50-36-1815	5569-14A2GS-T	14	50-36-1816	5569-14A2GS-210-T			14													
50-36-1825	5569-16A2GS-T	16	50-36-1826	5569-16A2GS-210-T			16													
50-36-1835	5569-18A2GS-T	18	50-36-1836	5569-18A2GS-210-T			18													
50-36-1845	5569-20A2GS-T	20	50-36-1846	5569-20A2GS-210-T			20													
39-30-1221	5569-22A2GS-T	22	50-36-1856	5569-22A2GS-210-T			22													
50-36-1865	5569-24A2GS-T	24	50-36-1866	5569-24A2GS-210-T			24													
26-01-3177	5569-02AGS3-210-T	2	50 μ" SELECT GOLD SEE NOTE 2 OPTION "GS3"	94V-0			26-01-3101	5569-02A2GS-BL-T	2	30 μ" SELECT GOLD SEE NOTE 2 OPTION "GS"	BLACK 94V-2									
26-01-3178	5569-04AGS3-210-T	4					NOT TOOLED	5569-04A2GS-BL-T	4											
		6			NOT TOOLED	5569-06A2GS-BL-T	6													
		8			NOT TOOLED	5569-08A2GS-BL-T	8													
26-01-3094	5569-10AGS3-210-T	10			NOT TOOLED	5569-10A2GS-BL-T	10													
		12			NOT TOOLED	5569-12A2GS-BL-T	12													
		14			NOT TOOLED	5569-14A2GS-BL-T	14													
		16			26-01-3108	5569-16A2GS-BL-T	16													
		18			NOT TOOLED	5569-18A2GS-BL-T	18													
		20			NOT TOOLED	5569-20A2GS-BL-T	20													
		22			NOT TOOLED	5569-22A2GS-BL-T	22													
		24			NOT TOOLED	5569-24A2GS-BL-T	24													

SYMBOLS	THIS DRAWING CONTAINS INFORMATION THAT IS PROPRIETARY TO MOLEX ELECTRONIC TECHNOLOGIES, LLC AND SHOULD NOT BE USED WITHOUT WRITTEN PERMISSION									
	DIMENSION UNITS		SCALE		CURRENT REV DESC: MIGRATE TO ECTR					
	IN/MM		1:1		EC NO: 172489 DRWN: ANESSER 2018/01/26 CHK'D: JBELL 2018/02/20 APPR: FSMITH 2018/02/22 INITIAL REVISION: DRWN: RJF 1988/02/16 APPR: FSMITH 2016/12/20					
	GENERAL TOLERANCES (UNLESS SPECIFIED)									
▽ = 0	4 PLACES	±		MM	INCH	PRODUCT CUSTOMER DRAWING DOCUMENT NUMBER: 55690002-SD DOC TYPE: PSD DOC PART: 000 REVISION: A MATERIAL NUMBER: SEE CHART CUSTOMER: GENERAL MARKET SHEET NUMBER: 4 OF 4				
▽ = 0	3 PLACES	±		± 0.01						
▽ = 0	2 PLACES	±	0.25	± 0.015						
▽ = 0	1 PLACE	±	0.38	±						
⊠ = 0	0 PLACES	±				THIRD ANGLE PROJECTION DRAWING: C-SIZE SERIES: 5569				
■ = 0	ANGULAR TOL		± 0.5 °							
▽ = 0	DRAFT WHERE APPLICABLE MUST REMAIN WITHIN DIMENSIONS									



MINI-FIT JR RIGHT ANGLE HEADER ASSEMBLIES WITH MOUNTING PEGS

PRODUCT CUSTOMER DRAWING

DOCUMENT NUMBER: 55690002-SD  
DOC TYPE: PSD  
DOC PART: 000  
REVISION: A

MATERIAL NUMBER: SEE CHART  
CUSTOMER: GENERAL MARKET  
SHEET NUMBER: 4 OF 4