

4-Bit D-Type Latch

The TC74HC375A is a high speed CMOS D-TYPE LATCH fabricated with silicon gate C²MOS technology.

It achieves the high speed operation similar to equivalent LSTTL while maintaining the CMOS low power dissipation.

It contains two groups of 2-bit latches controlled by an enable input (G1 • 2 or G3 • 4) and each group can be used in different circuits.

Data applied to the data inputs are transferred to the Q and \bar{Q} outputs when the enable inputs is high. When the enable input is low, the outputs are not affected.

All inputs are equipped with protection circuits against static discharge or transient excess voltage.

Features

- High Speed: $t_{pd} = 14\text{ns(Typ.)}$ at $V_{CC} = 5\text{V}$
- Low Power Dissipation: $I_{CC} = 4\mu\text{A(Max.)}$ at $T_a = 25^\circ\text{C}$
- High Noise Immunity: $V_{NIH} = V_{NIL} = 28\% V_{CC}(\text{Min.})$
- Output Drive Capability: 10 LSTTL Loads
- Symmetrical Output Impedance: $I_{OH} = I_{OL} = 4\text{mA}(\text{Min.})$
- Balanced Propagation Delays: $t_{pLH} = t_{pHL}$
- Wide Operating Voltage Range: $V_{CC}(\text{opr}) = 2\text{V} \sim 6\text{V}$
- Pin and Function Compatible with 74LS375

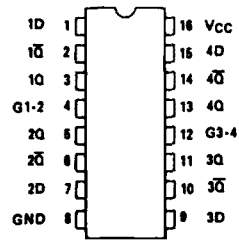
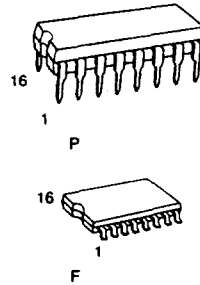

(TOP VIEW)
Pin Assignment

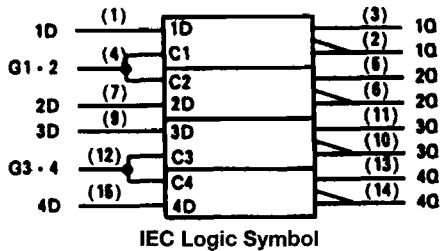

Truth Table

Inputs		Outputs		Function
D	G	Q	\bar{Q}	
L	H	L	H	-
H	H	H	L	-
X	L	Q_n	\bar{Q}_n	Latch

X: Don't Care

Absolute Maximum Ratings

Parameter	Symbol	Value	Unit
Supply Voltage Range	V_{CC}	-0.5 ~ 7	V
DC Input Voltage	V_{IN}	-0.5 ~ $V_{CC} + 0.5$	V
DC Output Voltage	V_{OUT}	-0.5 ~ $V_{CC} + 0.5$	V
Input Diode Current	I_{IK}	±20	mA
Output Diode Current	I_{OK}	±20	mA
DC Output Current	I_{OUT}	±25	mA
DC V_{CC} /Ground Current	I_{CC}	±50	mA
Power Dissipation	P_D	500(DIP)*/180(MFP)	mW
Storage Temperature	T_{stg}	-65 ~ 150	°C
Lead Temperature 10sec	T_L	300	°C

*500mW in the range of $T_a = -40^{\circ}\text{C} \sim 65^{\circ}\text{C}$. From $T_a = 65^{\circ}\text{C}$ to 85°C a derating factor of $-10\text{mW}/^{\circ}\text{C}$ shall be applied until 300mW.

Recommended Operating Conditions

Parameter	Symbol	Value	Unit
Supply Voltage	V_{CC}	2 ~ 6	V
Input Voltage	V_{IN}	0 ~ V_{CC}	V
Output Voltage	V_{OUT}	0 ~ V_{CC}	V
Operating Temperature	T_{opr}	-40 ~ 85	°C
Input Rise and Fall Time	t_r, t_f	0 ~ 1000($V_{CC} = 2.0\text{V}$) 0 ~ 500($V_{CC} = 4.5\text{V}$) 0 ~ 400($V_{CC} = 6.0\text{V}$)	ns

DC Electrical Characteristics

Parameter	Symbol	Test Condition	$T_a = 25^{\circ}\text{C}$			$T_a = -40 \sim 85^{\circ}\text{C}$		Unit		
			V_{CC}	Min.	Typ.	Max.	Min.		Max.	
High-Level Input Voltage	V_{IH}	-	2.0	1.5	-	-	1.5	-	V	
			4.5	3.15	-	-	3.15	-		
			6.0	4.2	-	-	4.2	-		
Low-Level Input Voltage	V_{IL}	-	2.0	-	-	0.5	-	0.5	V	
			4.5	-	-	1.35	-	1.35		
			6.0	-	-	1.8	-	1.8		
High-Level Output Voltage	V_{OH}	$V_{IN} = V_{IH}$ or V_{IL}	$I_{OH} = -20\mu\text{A}$	2.0	1.9	2.0	-	1.9	-	V
				4.5	4.4	4.5	-	4.4	-	
				6.0	5.9	6.0	-	5.9	-	
High-Level Output Voltage	V_{OH}	$V_{IN} = V_{IH}$ or V_{IL}	$I_{OH} = -4\text{mA}$ $I_{OH} = -5.2\text{mA}$	4.5	4.18	4.31	-	4.13	-	V
				6.0	5.68	5.80	-	5.63	-	
				6.0	-	-	-	-	-	
Low-Level Output Voltage	V_{OL}	$V_{IN} = V_{IH}$ or V_{IL}	$I_{OL} = 20\mu\text{A}$	2.0	-	0.0	0.1	-	0.1	V
				4.5	-	0.0	0.1	-	0.1	
				6.0	-	0.0	0.1	-	0.1	
Low-Level Output Voltage	V_{OL}	$V_{IN} = V_{IH}$ or V_{IL}	$I_{OL} = 4\text{mA}$ $I_{OL} = 5.2\text{mA}$	4.5	-	0.17	0.26	-	0.33	V
				6.0	-	0.18	0.26	-	0.33	
				6.0	-	-	-	-	-	
Input Leakage Current	I_{IN}	$V_{IN} = V_{CC}$ or GND	6.0	-	-	±0.1	-	±1.0	μA	
Quiescent Supply Current	I_{CC}	$V_{IN} = V_{CC}$ or GND	60	-	-	4.0	-	40.0		

Timing Requirements (Input $t_r = t_f = 6\text{ns}$)

Parameter	Symbol	Test Condition	Ta = 25°C		Ta = -40 ~ 85°C		Unit
			V _{CC}	Typ.	Limit	Limit	
Minimum Pulse Width (G)	$t_{W(H)}$	-	2.0	-	75	95	ns
			4.5	-	15	19	
			6.0	-	13	16	
Minimum Setup Time	t_s	-	2.0	-	75	95	
			4.5	-	15	19	
			6.0	-	13	16	
Minimum Hold Time	t_h	-	2.0	-	0	0	
			4.5	-	0	0	
			6.0	-	0	0	

AC Electrical Characteristics (C_L = 15pF, V_{CC} = 5V, Ta = 25°C)

Parameter	Symbol	Test Condition	Min.	Typ.	Max.	Unit
Output Transition Time	t_{TLH}	-	-	4	8	ns
	t_{THL}					
Propagation Delay Time (DATA-Q, \bar{Q})	t_{PLH}	-	-	14	20	
	t_{PHL}					
Propagation Delay Time (G-Q, \bar{Q})	t_{PLH}	-	-	13	20	
	t_{PHL}					

AC Electrical Characteristics (C_L = 50pF, Input $t_r = t_f = 6\text{ns}$)

Parameter	Symbol	Test Condition	Ta = 25°C			Ta = -40 ~ 85°C		Unit	
			V _{CC}	Min.	Typ.	Max.	Min.		Max.
Output Transition Time	t_{TLH} t_{THL}	-	2.0	-	30	75	-	95	ns
			4.5	-	8	15	-	19	
			6.0	-	7	13	-	16	
Propagation Delay Time (DATA-Q, \bar{Q})	t_{PLH}	-	2.0	-	60	120	-	150	
			4.5	-	17	24	-	30	
			6.0	-	15	20	-	26	
Propagation Delay Time (G-Q, \bar{Q})	t_{PHL}	-	2.0	-	56	120	-	150	
			4.5	-	16	24	-	30	
			6.0	-	14	20	-	26	
Input Capacitance	C _{IN}	-	-	5	10	-	10	pF	
Power Dissipation Capacitance	C _{PD(1)}	-	-	55	-	-	-		

Note (1) C_{PD} is defined as the value of the internal equivalent capacitance which is calculated from the operating current consumption without load.

Average operating current can be obtained by the equation:

$$I_{CC(oper)} = C_{PD} \cdot V_{CC} \cdot f_{IN} + I_{CC}/4(\text{per Latch})$$

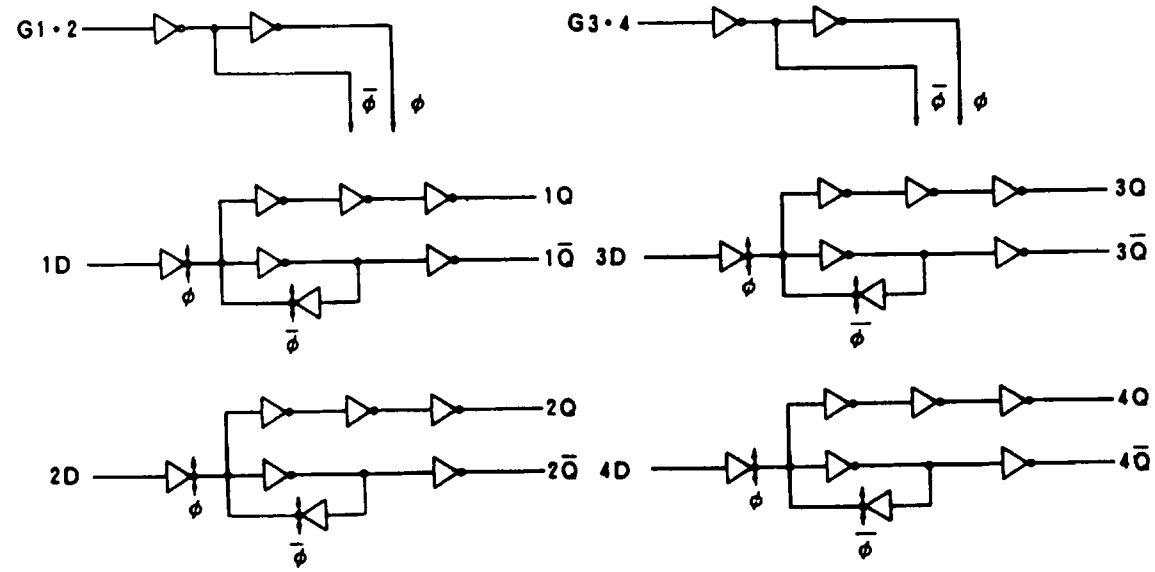

Logic Diagram