

THIS DRAWING CONTAINS INFORMATION PROPRIETARY TO RF INDUSTRIES,
 ANY UNAUTHORIZED USE OF THIS DRAWING IS EXPRESSLY PROHIBITED
 WITHOUT WRITTEN PERMISSION FROM RF INDUSTRIES.
 ANY VIOLATION IS PUNISHABLE UNDER U.S. COPYRIGHT LAWS.

ALL DIMENSIONS ARE REFERENCE ONLY

PART NO.

RFD-1605-2-L2

REV	DESCRIPTION	DWN	DATE	APPROVED
-	ENGINEERING RELEASE	CZS	10/17/06	JDMc

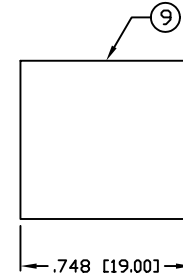
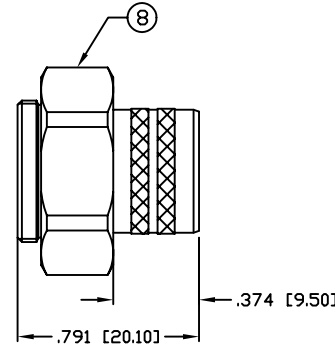
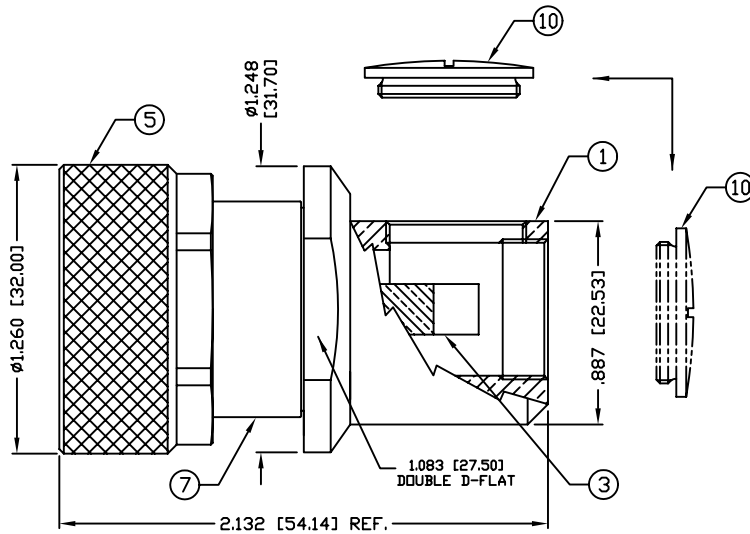

RECOMMENDED CRIMP DIE: .6"

SPECIFICATIONS:

IMPEDANCE: 50 Ohms
 FREQUENCY RANGE: 0-7.5 GHz
 PEAK POWER: 13.2 Kw max.
 AVERAGE POWER: 3.0 Kw max.
 TEMPERATURE RANGE: -55°C TO 150°C
 FOR TIMES LMR-600, LMR-600 ULTRAFLEX & T-COM-600

NOTE: ATTACH CABLE TO CONNECTOR BY
 SOLDERING THE CABLE INNER CONDUCTOR
 TO THE PIN SLOT INSIDE THE CONNECTOR

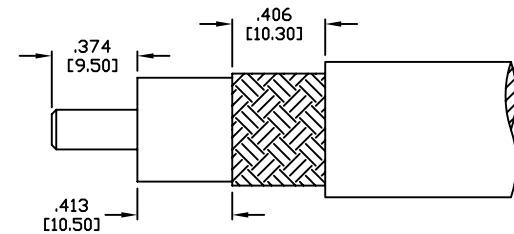

RECOMMENDED STRIPPING DIMENSIONS

1	BODY	1	BRASS	SILVER, 120μ"	008974	
2	INSULATOR	1	PTFE	----		
3	PIN	1	BRASS	SILVER, 200μ"		
4	GASKET	1	SILICONE	----		
5	SHELL	1	BRASS	SILVER, 120μ"		
6	GASKET	1	SILICONE	----		
7	GROUND RING	1	BRASS	SILVER, 120μ"		
8	FERRULE STUD	1	BRASS	SILVER, 120μ"		
9	FERRULE	1	BRASS	SILVER, 120μ"		
10	SCREW CAP	1	BRASS	SILVER, 120μ"		
11					DRAWN C. ZUNIGA	
12					CHECKED	
13					ORJ DRAWN C. ZUNIGA	
14					01/30/07	
#	DESCRIPTION	QTY	MATERIAL	FINISH	APPROVALS	DATE

**RoHS
COMPLIANT**

DIMENSIONS ARE IN INCHES
 AND [MILLIMETERS]
 UNLESS OTHERWISE NOTED
 TOLERANCES ARE:
 DECIMALS DIAMETER

RF connectors
 DIVISION OF RF INDUSTRIES, LTD.

7610 MIRAMAR RD
 SAN DIEGO, CA 92126
 (858) 549-6340
 (858) 549-6345 FAX

7/16 PLUG, CRIMP

SIZE	CABLE GROUP	DWG NO.	REV
A	L2	RFD-1605-2-L2	-
SCALE:	NTS	CAD FILE	OUTLINE
SHEET 1		OF 1	