

FEATURES

- 1 μV input referred noise
- 1.0 to 5 VDC operating range
- 73 dB typical gain (adjustable)
- 0.28 to 2.0 mA range of transducer current
- 1% electrical distortion
- the first and second blocks, or second and third blocks can be DC coupled
- 100 Hz to 50 kHz frequency response
- suitable for active filtering

STANDARD PACKAGING

- 10 PIN MICROpac
- 10 pin MINIpac
- 10 pin PLID[®]
- 10 pin SLT
- Chip (52 x 49 mils)

DESCRIPTION

The LC508 is a 10 pin Class A amplifier utilizing Gennum's proprietary low voltage bipolar JFET technology. It consists of 3 single ended, low noise inverting gain blocks. The first two blocks have a typical open loop gain of 50 dB. The closed loop gain is set by the ratio of the feedback resistor to the source impedance. The third block is an open collector output stage with the bias being set by R_E and V_{RE} at pin 8 which is 54 mV.

Typically, the gain of the first two blocks is set to 25 dB each, with the third block at 23 dB, giving a total gain of 73 dB.

Gain trim can be accomplished with the use of a feedback resistor on the first block, while the volume control is used as the feedback control on the second block. This gives a volume control range greater than 40 dB.

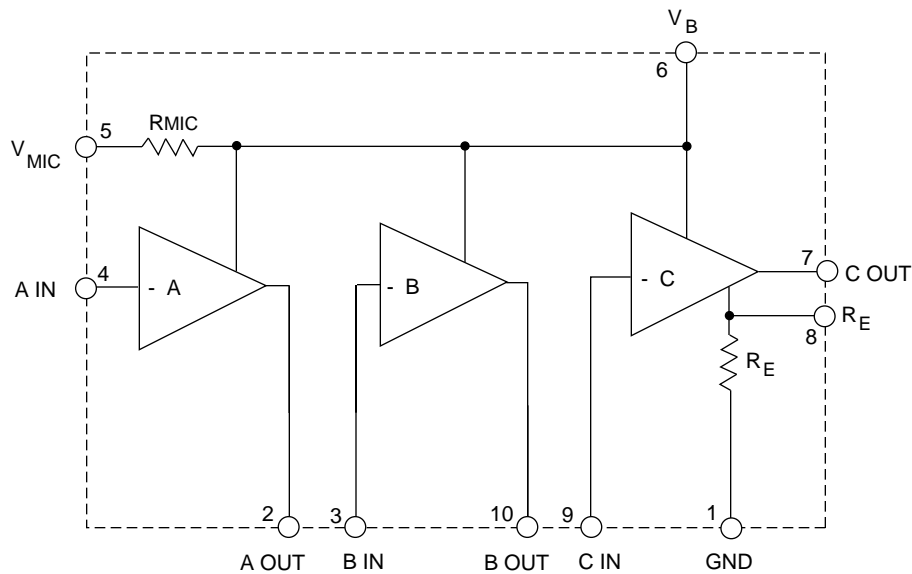

BLOCK DIAGRAM

ABSOLUTE MAXIMUM RATINGS

PARAMETER	VALUE / UNITS
Supply Voltage	5V DC
Power Dissipation	25 mW
Operating Temperature	-10° to + 40°C
Storage Temperature	-20° to + 70°C

CAUTION
CLASS 1 ESD SENSITIVITY



PIN CONNECTION

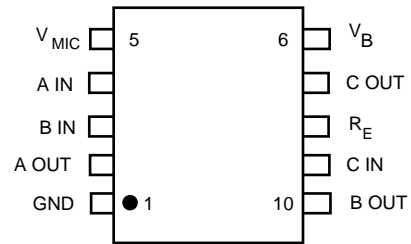

ELECTRICAL CHARACTERISTICS

Conditions: Supply Voltage = 1.3 VDC, Frequency = 1 kHz, Temperature = 25 °C

PARAMETER	SYMBOL	CONDITIONS	MIN	TYP	MAX	UNITS
Gain (Closed Loop)	A_{CL}	$V_{OUT} = 500 \text{ VRMS}$	69	73	77	dB
Amplifier Current	I_{AMP}	$I_{AMP} = I_A + I_{MIC}$	160	245	340	μA
Transducer Current	$I_{TRANS H}$	$R_E = 47.5$	1.1	1.3	1.7	mA
Transducer Current	$I_{TRANS L}$	$R_E = \infty$	200	275	350	μA
Distortion	THD	$V_{OUT} = 500 \text{ VRMS}$	-	1	4	%
Input Referred Noise	IRN	NFB 0.2 to 10kHz at 12dB/Oct	-	1	2	μV
Stable with Battery Resistance to	R_B		-	-	22	Ω
Input Bias Current	I_B		-50	0	50	nA
On Chip Emitter Resistor	R_E		-	200	-	Ω
Emitter Bias Voltage (pin 8)	V_{RE}		-	54	-	mV
Microphone Decoupling Resistor	R_{MIC}		-	4	-	k Ω

All switches and parameters remain as shown in Test Circuit unless otherwise stated in Conditions column.

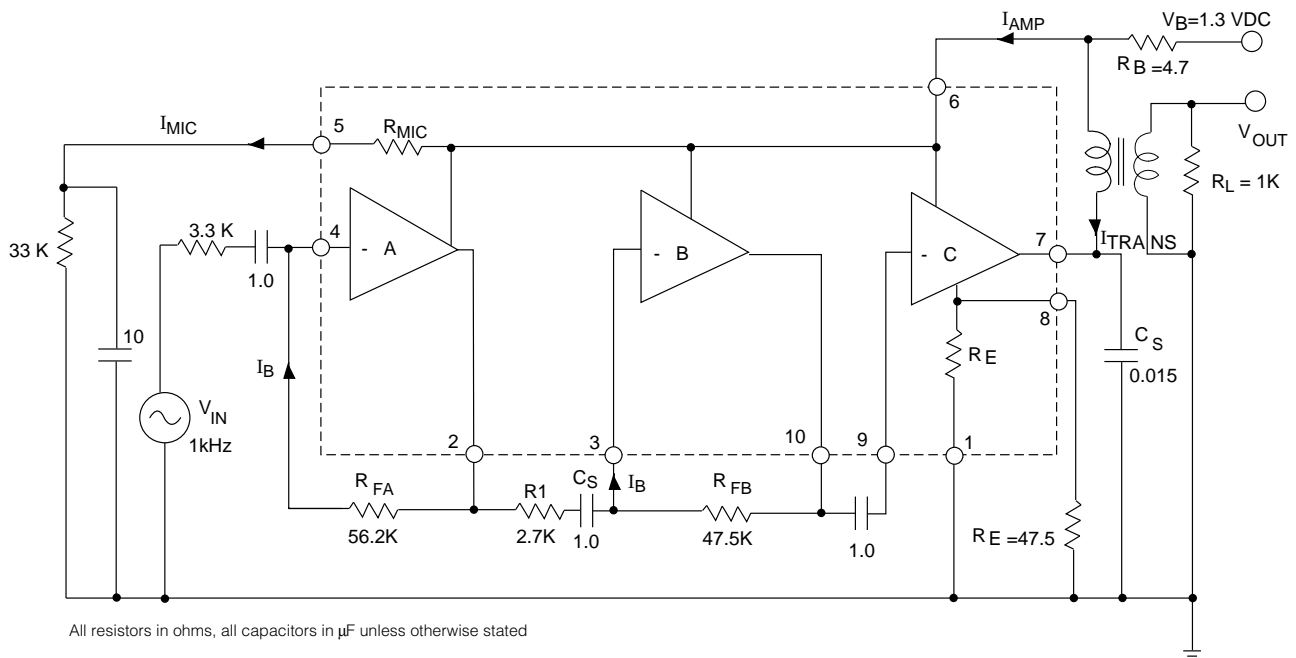

Fig. 1 Test Circuit

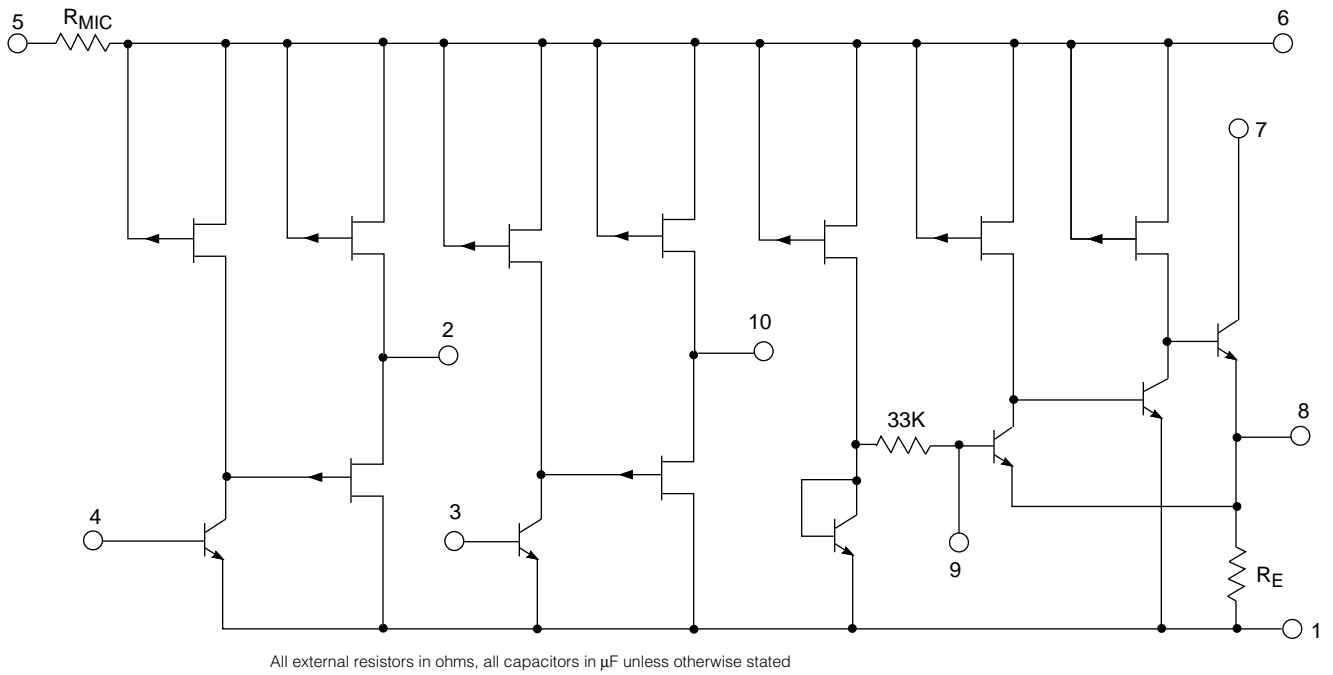

Fig. 2 Functional Schematic

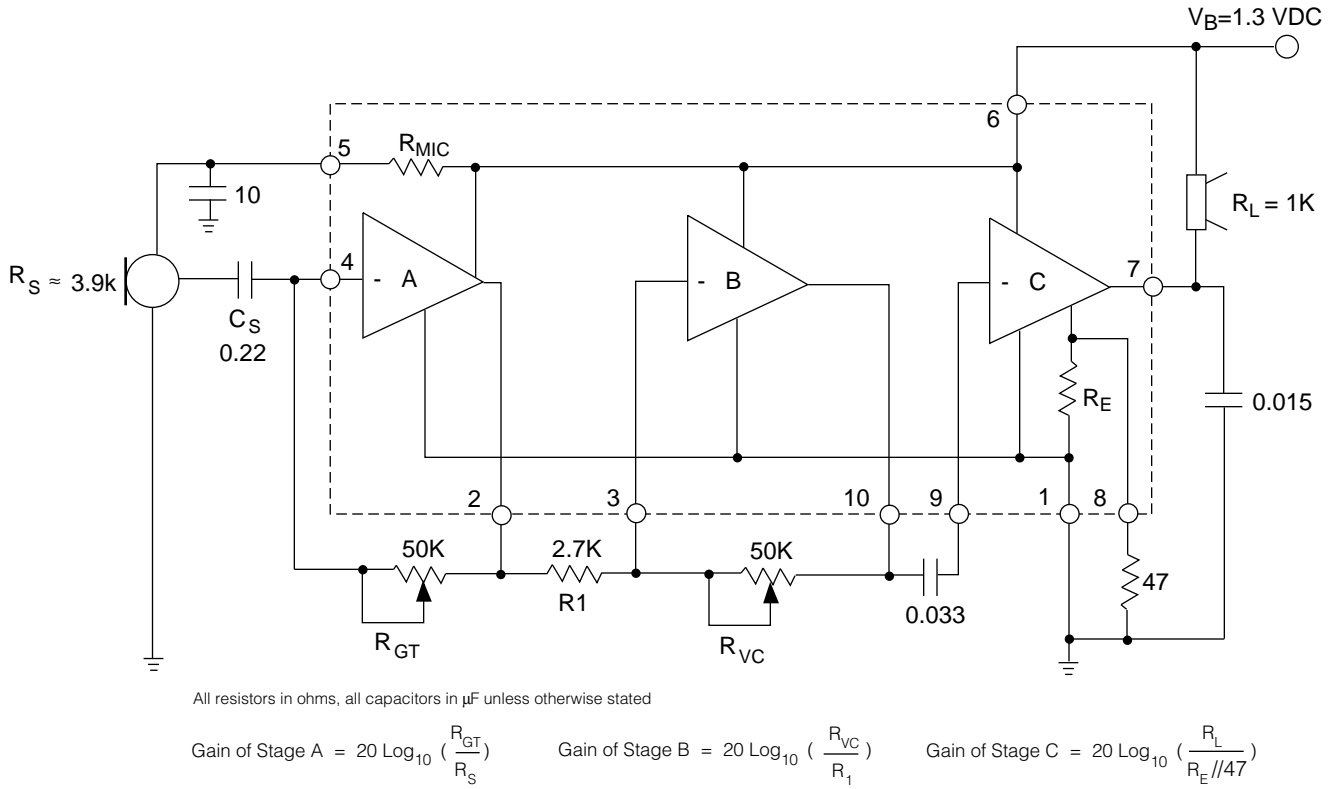

Fig. 3 Typical Hearing Aid Application

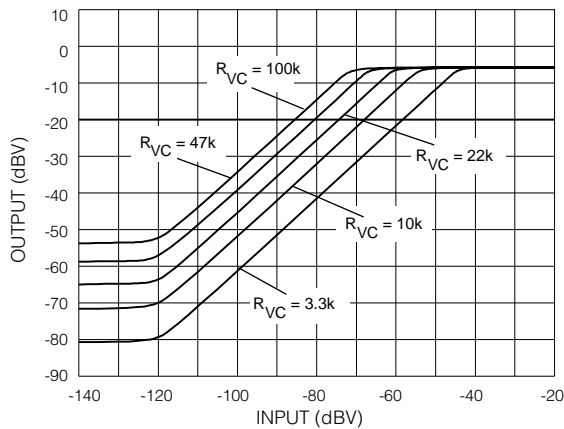

Fig. 4 I/O Characteristics at Various R_{VC} Values

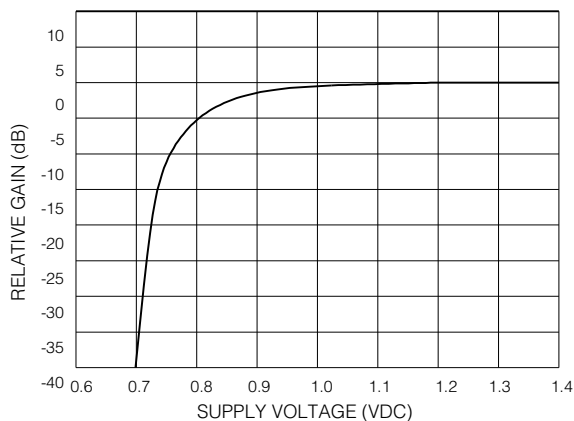

Fig.6 Gain vs Supply Voltage

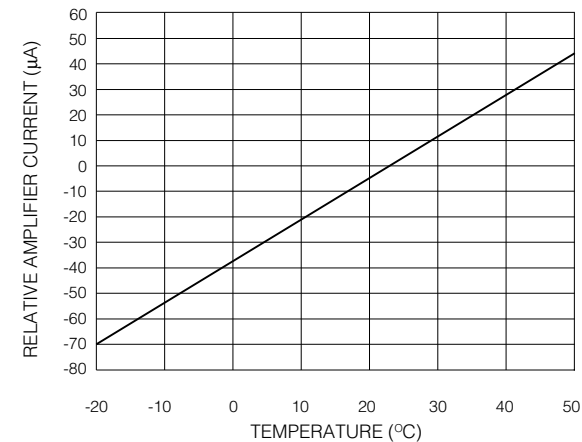

Fig. 8 Amplifier Current vs Temperature

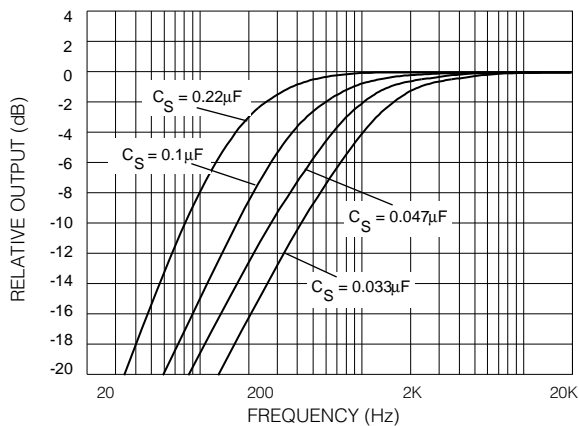

Fig. 5 Frequency Response at Various C_S Values

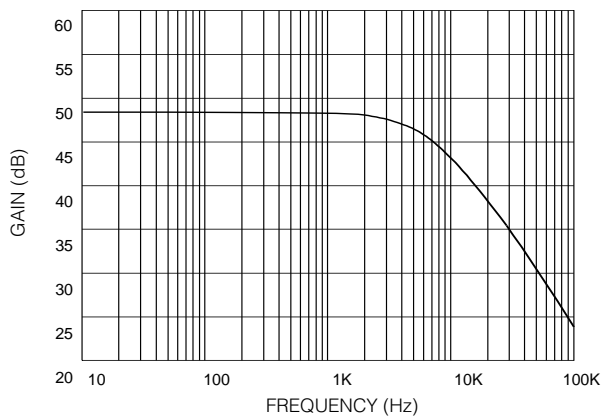

Fig.7 Preamplifier A Open Loop Frequency Response

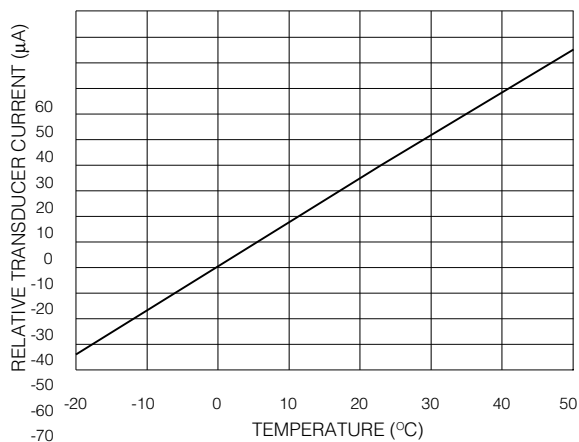

Fig. 9 Transducer Current vs Temperature

REVISION NOTES

Au bump removed.

Gennum Corporation assumes no responsibility for the use of any circuits described herein and makes no representations that they are free from patent infringement.
© Copyright 1989 Gennum Corporation. All rights reserved. Printed in Canada.

DOCUMENT IDENTIFICATION
PRODUCT PROPOSAL

This data has been compiled for market investigation purposes only, and does not constitute an offer for sale.

ADVANCE INFORMATION NOTE

This product is in development phase and specifications are subject to change without notice. Gennum reserves the right to remove the product at any time. Listing the product does not constitute an offer for sale.

PRELIMINARY DATA SHEET

The product is in a preproduction phase and specifications are subject to change without notice.

DATA SHEET

The product is in production. Gennum reserves the right to make changes at any time to improve reliability, function or design, in order to provide the best product possible.