

Features

- ❑ CMOS, Mask-Programmed Logic Device (MPLD) capable of implementing high-density custom logic functions
- ❑ High-volume replacement for EPM5032 EPLD designs
- ❑ Zero-power operation (typically 8 μ A standby)
- ❑ Active power of 8 mA at 20 MHz
- ❑ High speed ($t_{PD} = 20$ ns) with 71-MHz clock rates
- ❑ TTL I/O compatibility
- ❑ MAX+PLUS and MAX+PLUS II development system support, featuring schematic capture, Altera Hardware Description Language (AHDL), and waveform design entry; logic minimization and synthesis; and full timing simulation
- ❑ Available in plastic 28-pin dual in-line (PDIP) and J-lead chip carrier (PLCC) packages

General Description

Altera's MPM5032 MPLD provides a high-volume replacement for EPM5032 designs. It is pin-, function-, and timing-compatible with existing EPM5032 designs. MPM5032 designs are created with Altera's MAX+PLUS or MAX+PLUS II development system and prototyped with EPM5032 EPLDs. The source files are then converted to produce the MPLD. The MPM5032 MPLD is available in 28-pin DIP and PLCC packages. See Figure 5.

This data sheet provides minimum and maximum AC and DC parametric values for the MPM5032 MPLD. For additional information, refer to the *EPM5016 to EPM5192 EPLDs: High-Speed, High-Density MAX 5000 Devices Data Sheet* in this data book.

Figure 5. MPM5032 Package Pin-Out Diagrams

Package outlines not drawn to scale.

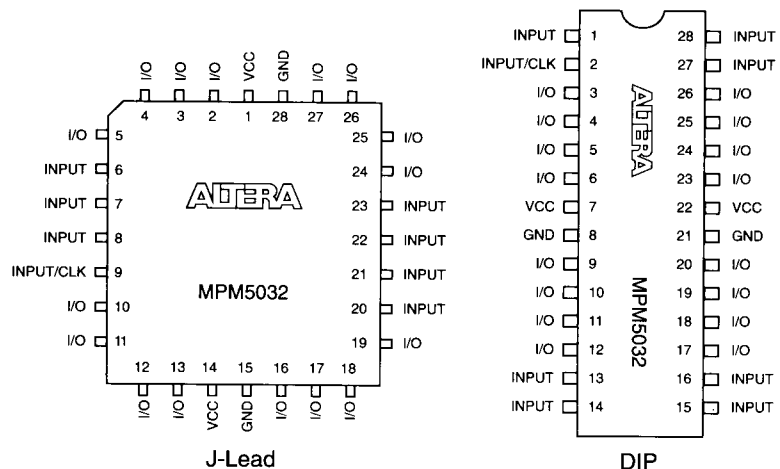

Absolute Maximum Ratings Note: See *Operating Requirements for EPLDs* in this data book.

Symbol	Parameter	Conditions	Min	Max	Unit
V_{CC}	Supply voltage	With respect to GND	-2.0	7.0	V
V_I	DC input voltage	See Note (1)	-2.0	7.0	V
I_{MAX}	DC V_{CC} or GND current			300	mA
I_{OUT}	DC output current, per pin		-25	25	mA
P_D	Power dissipation			1500	mW
T_{STG}	Storage temperature	No bias	-65	150	°C
T_{AMB}	Ambient temperature	Under bias	-65	135	°C
T_J	Junction temperature	Under bias		150	°C

Recommended Operating Conditions

Symbol	Parameter	Conditions	Min	Max	Unit
V_{CC}	Supply voltage		4.75	5.25	V
V_I	Input voltage		0	V_{CC}	V
V_O	Output voltage		0	V_{CC}	V
T_A	Operating temperature	For commercial use	0	70	°C
t_R	Input rise time			100	ns
t_F	Input fall time			100	ns

DC Operating Conditions See Notes (2), (3)

Symbol	Parameter	Conditions	Min	Typ	Max	Unit
V_{IH}	High-level input voltage		2.0		$V_{CC} + 0.3$	V
V_{IL}	Low-level input voltage		-0.3		0.8	V
V_{OH}	High-level TTL output voltage	$I_{OH} = -4$ mA DC	2.4			V
V_{OL}	Low-level output voltage	$I_{OL} = 8$ mA DC			0.45	V
I_I	Input leakage current	$V_I = V_{CC}$ or GND	-10		10	μA
I_{OZ}	Tri-state output off-state current	$V_O = V_{CC}$ or GND	-40		40	μA
I_{CC1}	V_{CC} supply current (standby)	$V_I = V_{CC}$ or GND, No load		8		μA
I_{CC3}	V_{CC} supply current (active)	$V_I = V_{CC}$ or GND, No load, $f = 1.0$ MHz, See Note (4)		0.4		mA

Capacitance

Symbol	Parameter	Conditions	Min	Max	Unit
C_{IN}	Input capacitance	$V_{IN} = 0$ V, $f = 1.0$ MHz		10	pF
C_{OUT}	Output capacitance	$V_{OUT} = 0$ V, $f = 1.0$ MHz		12	pF

AC Operating Conditions See Note (3)

External Timing Parameters			MPM5032-20 Note (5)		MPM5032-25		
Symbol	Parameter	Conditions	Min	Max	Min	Max	Unit
t_{PD1}	Input to non-registered output	C1 = 35 pF		20		25	ns
t_{PD2}	I/O input to non-registered output			20		25	ns
t_{SU}	Global clock setup time		12		15		ns
t_H	Global clock hold time		0		0		ns
t_{CO1}	Global clock to output delay	C1 = 35 pF		12		15	ns
t_{CH}	Global clock high time		7		8		ns
t_{CL}	Global clock low time		7		8		ns
t_{ASU}	Array clock setup time		9		12		ns
t_{AH}	Array clock hold time		9		12		ns
t_{ACO1}	Array clock to output delay	C1 = 35 pF		20		25	ns
t_{ACH}	Array clock high time	See Note (6)	7		9		ns
t_{ACL}	Array clock low time		9		11		ns
t_{CNT}	Minimum global clock period			16		20	ns
f_{CNT}	Max. internal global clock frequency	See Note (4)	62.5		50		MHz
t_{ACNT}	Minimum array clock period			16		20	ns
f_{ACNT}	Max. internal array clock frequency	See Note (4)	62.5		50		MHz
f_{MAX}	Maximum clock frequency	See Note (7)	71.4		62.5		MHz

Notes to tables:

- (1) Minimum DC input is -0.3 V. During transitions, the inputs may undershoot to -2.0 V or overshoot to 7.0 V for periods shorter than 20 ns under no-load conditions.
- (2) Typical values are for $T_A = 25^\circ\text{C}$ and $V_{CC} = 5\text{ V}$.
- (3) Operating conditions: $V_{CC} = 5\text{ V} \pm 5\%$, $T_A = 0^\circ\text{C}$ to 70°C for commercial use.
- (4) Measured with a device programmed as a 32-bit counter.
- (5) This version is under development. Contact Altera Marketing at (408) 984-2800 for information on availability.
- (6) This parameter is measured with a positive-edge-triggered clock at the register. For negative-edge clocking, the t_{ACH} and t_{ACL} parameters must be swapped.
- (7) The f_{MAX} values represent the highest frequency for pipelined data.

Figure 6 shows typical supply current versus frequency for MPM5032 MPLDs.

Figure 6. MPM5032 I_{CC} vs. Frequency

