

QSFCT521T, 2521T



**High Speed CMOS
8-bit
Identity Comparator**

QS54/74FCT521T
QS54/74FCT2521T

FEATURES/BENEFITS

- Pin and function compatible to the 74F521 74FCT521 and 74FCT540T/1T
- CMOS power levels: <7.5 mW static
- Available in DIP, ZIP, SOIC, QSOP, LCC
- Undershoot clamp diodes on all inputs
- TTL-compatible input and output levels
- Ground bounce controlled outputs
- Reduced output swing of 0-3.5V
- Military product compliant to MIL-STD-883

FCT-T540T/1T

- JEDEC-FCT spec compatible
- Fastest CMOS logic family available
- Standard thru D speed grades; 3.9ns tPD for D
- I_{OL} = 48 mA Com., 32mA Mil.

FCT-T 2540T/1T

- Built-in 25Ω series resistor outputs reduce reflection and other system noise
- Standard thru D speed grades ; 3.9ns tPD for D
- I_{OL} = 12mA Com.

DESCRIPTION

The QS74FCT521AT/BT/CT/DT and QS74FCT2521AT/BT/CT/DT are high speed CMOS TTL-compatible 8-bit identity comparators. = Two words of up to eight bits are compared and a low output is provided when the words match. An expansion input allows the comparison to be extended over multiple words. All inputs have clamp diodes for undershoot noise suppression. All outputs have ground bounce suppression (see QSI Application Note AN-001).

FUNCTIONAL BLOCK DIAGRAM

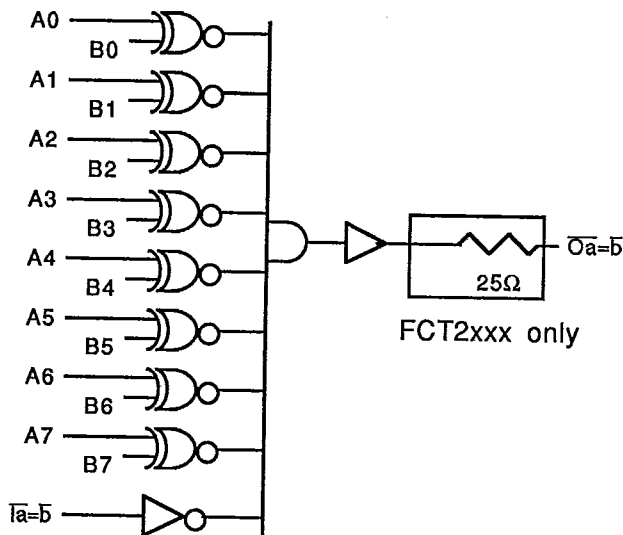

QSFCT521T, 2521T

PIN CONFIGURATIONS

PDIP, SOIC, QSOP

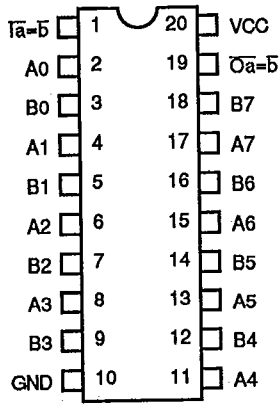

ZIP

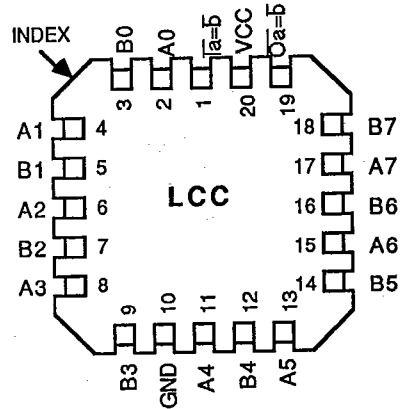
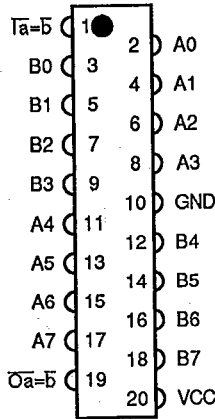

ALL PINS TOP VIEW

PIN DESCRIPTION

Pin Name	I/O	Description
A0-A7	I	Word A
B0-B7	I	Word B
Ta=b	I	Expansion Input
Oa=b	O	Compare Output

FUNCTION TABLE

	Inputs		Function
	A0-A7, B0-B7	Ta=b, Oa=b	
A0-7 = B0-7	L	L	Compare Equal
A0-7 ≠ B0-7	L	H	Compare Not Equal
X	H	H	Expand Input Not Valid

ABSOLUTE MAXIMUM RATINGS

Supply Voltage to Ground..... -0.5V to +7.0V
 DC Output Voltage V_O -0.5V to 7.0V
 DC Input Voltage V_I -0.5V to 7.0V
 AC Input Voltage (for a pulse width ≤ 20 ns)..... -3.0V
 DC Input Diode Current with $V_I < 0$ -20 mA
 DC Output Diode Current with $V_O < 0$ -50 mA
 DC Output Current Max. sink current/pin..... 120 mA
 Maximum Power Dissipation..... 0.5 watts
 T_{STG} Storage Temperature..... -65° to +165°C

CAPACITANCE

TA = 25 °C, f = 1 MHz, Vin = 0V, Vout = 0 V

Pins	SOIC	QSOP	PDIP,LCC	ZIP	Unit
1-9,11-18	4	4	5	7	pF
19	6	6	7	9	pF
-----	8	8	9	10	pF

Note: Capacitance is characterized but not tested

4

DC ELECTRICAL CHARACTERISTICS OVER OPERATING RANGE

Commercial $T_A=0^{\circ}\text{C}$ to 70°C , $V_{CC}=5.0\text{V}\pm 5\%$ Military $T_A=-55^{\circ}\text{C}$ to 125°C , $V_{CC}=5.0\text{V}\pm 10\%$

Symbol	Parameter	Test Conditions		Min	Typ (1)	Max	Unit
V _{ih}	Input High Voltage	Logic HIGH for All Inputs		2.0	-	-	Volts
V _{il}	Input LOW Voltage	Logic LOW for All Inputs		-	-	0.8	
ΔV_t	Input Hysterisis	V _{ih} - V _{il} for All Inputs		-	0.2	-	
I _{ih} I _{il}	Input Current Input HIGH or LOW	V _{cc} = MAX	$0 \leq V_{in} < V_{cc}$	-	-	5	μA
	I _{oz}	Off State Output Current (Hi-Z) V _{cc} = MAX, $0 \leq V_{in} \leq V_{cc}$		-	-	5	
I _{os}	Short Circuit Current FCTXXX	V _{cc} = MAX, V _o = GND (2,3)		-60	-	-225	mA
I _{or}	Current Drive FCT2XXX	V _{cc} = Min, V _o = 2.0V (3)		50	-	-	mA
V _{ic}	Input Clamp Voltage	V _{cc} = MIN, I _{in} = 18 mA (3)		-	-0.7	-1.2	Volts
V _{oh}	Output HIGH Voltage FCTXXX & FCT2XXX	V _{cc} = MIN	I _{oh} = 12 mA (MIL)	2.4	-	-	Volts
			I _{oh} = 15 mA (COM)	2.4	-	-	
V _{ol}	Output LOW Voltage FCTXXX	V _{cc} = MIN	I _{ol} = 32 mA (MIL)	-	-	0.50	
			I _{ol} = 48 mA (COM)	-	-	0.50	
	Output LOW Voltage FCT2XXX (25 Ω)	V _{cc} = MIN	I _{ol} = 12 mA (MIL)	-	-	0.50	
			I _{ol} = 12 mA (COM)	-	-	0.50	
R _{out}	Output Resistance FCT2XXX (25 Ω)	V _{cc} = MIN	I _{ol} = 12 mA (MIL)	-	25	-	Ω
			I _{ol} = 12 mA (COM)	20	28	40	

Notes:

1. Typical values indicate $V_{CC}=5.0\text{V}$ and $T_A=25^{\circ}\text{C}$.
2. Not more than one output should be shorted and the duration is ≤ 1 second.
3. These parameters are guaranteed by design but not tested.

QSFCT521T, 2521T

POWER SUPPLY CHARACTERISTICS

Symbol	Parameter	Test Conditions (1)	Min	Max	Unit
I _{cc}	Quiescent Power Supply Current	V _{cc} = MAX, freq = 0 0V ≤ V _{in} ≤ 0.2V or V _{cc} - 0.2V ≤ V _{in} ≤ V _{cc}	-	1.5	mA
ΔI _{cc}	Supply Current per Input @ TTL HIGH	V _{cc} = MAX, V _{in} = 3.4 V, freq = 0 (2)	-	2.0	
Q _{ccd}	Supply Current per input per mHz	V _{cc} = MAX, Outputs open and enabled One bit toggling @ 50% duty cycle Other inputs at GND or V _{cc} (3,4)	-	0.25	mA/ MHz

1. For conditions shown as MIN or MAX use the appropriate values specified under DC specifications.
2. Per TTL driven input (V_i=3.4V)
3. For flipflops Q_{ccd} is measured by switching one of the data input pins so that the output changes every clock cycle. This is a measurement of device power consumption only and does not include power to drive load capacitance or tester capacitance. This parameter is guaranteed by design but not tested.
4. I_c can be computed using the above parameters as explained in the Technical Overview section.

QSFCT521T, 2521T

SWITCHING CHARACTERISTICS OVER OPERATING RANGE

Commercial TA = 0° C to 70°C, Vcc = 5.0V±5% Military TA = -55°C to 125° C, Vcc = 5.0V±10%
 Cload = 50 pF, Rload = 500Ω unless otherwise noted. Units are nanoseconds unless otherwise noted.

Symbol	Description		521T 2521		521AT 2521A		521BT 2521B		521CT 2521C		521DT 2521D		Unit
			Min	Max	Min	Max	Min	Max	Min	Max	Min	Max	
tPHL	Propagation Delay Ai = Bi to $\overline{Oa=b}$ (1)	Com	1.5	11	1.5	7.2	1.5	5.5	1.5	4.5	1.5	4.1	ns
tPLH		Mil	1.5	15	1.5	9.5	1.5	7.3	1.5	5.1			
tPHLX	Propagation Delay Ia=b to $\overline{Oa=b}$ (1)	Com	1.5	10	1.5	6	1.5	4.6	1.5	4.1	1.5	3.9	
tPLHX		Mil	1.5	9	1.5	7.8	1.5	6.0	1.5	4.5			

Notes:

1. Minimum guaranteed but not tested