

Driver MMIC
Advanced Product Information
Rev 0

1900 MHz Band PCS GaAs Power Amplifier IC

<p>DESCRIPTION: The AWD1900 is a monolithic Driver Amplifier suited for PCS telephone applications.</p> <p>FEATURES: High Linearity Built in Step Attenuator High Gain 28 Pin SSOP Plastic Package Switchable RF Output Low Cost Single Supply</p>	
--	--

MAX. RATING

PIN	SIGNAL	MAX. RATING	PIN	SIGNAL	MAX. RATING
4	V_{DS1}	$7.5 V_{DC}, 0 V_{DC}$	16	RF_{IN}	0 dBm
10	V_{DS2}	$7.5 V_{DC}, 0 V_{DC}$	19	V_{REF}	5 V, OV_{DC}
11	V_{DS1}	$7.5 V_{DC}, 0 V_{DC}$	24	V_{CSW}	5 V, OV_{DC}
13	V_{CA}	$5 V_{DC}, 0 V_{DC}$			

Operating Temperature: - 20° to 70°
Storage Temperature: - 55° to 100°

ELECTRICAL CHARACTERISTICS: ⁽¹⁾

$f = 1850 - 1910$ MHz, $V_{DS1} = V_{DS2} = V_{DS3} = + 5 V_{DC}$, $V_{REF} = + 3.6 V_{DC}$, $T_c = 25$ °C, 50Ω System.

PARAMETER	SYMBOL	MIN.	TYP.	MAX.	UNIT
Frequency	f_o	1850		1910	MHz
Power Output	P_{OUT}				
High				10.5	dBm
Low				- 5	dBm
Gain	Gain				
High *			32.5		dBm
Low			17.5		dBm
Adjacent Channel Power Rejection (with CDMA waveform) at offset of ± 1.25 MHz, measured in 30 KHz bandwidth @ $P_{OUT} = 10.5$ dBm			40		dBc
Harmonic ⁽²⁾	2nd 3rd		35 45		dBc
Stability: - 80 dBc, all spurious outputs relative to desired signal			3:1		VSWR load, all phase angles $V_{DS1} = V_{DS2} = V_{DS3} = + 5.0$ V, $Z_s = 50 \Omega$
Quiescent Current			100		mA
Input Return Loss ⁽¹⁾			15		dB

* Used at maximum power

ELECTRICAL CHARACTERISTICS: ⁽¹⁾

f = 1850 - 1910 MHz, $V_{DS1} = V_{DS2} = V_{DS3} = + 5 V_{DC}$, $V_{REF} = + 3.6 V_{DC}$, $T_c = 25^\circ C$, 50Ω System.

PARAMETER	SYMBOL	MIN.	TYP.	MAX.	UNIT
Noise Figure					
High Mode			2.7		dB
Low Mode			8		dB
Attenuator			15		dB
Isolation (RF _{OUT1} to RF _{OUT2})			15		dB

Notes:

1: As measured in ANADIGICS test fixture

2: Measured @ Pout = 10.5 dBm.

Attenuator Control pin (13)voltage	Attenuation Value
0.2v	0
2.9v	15

RF output control pin 24 voltage	Attenuation Value
0.2	RF→RF _{OUT1}
2.9	RF→RF _{OUT2}

3. Case Outline and Pin Description

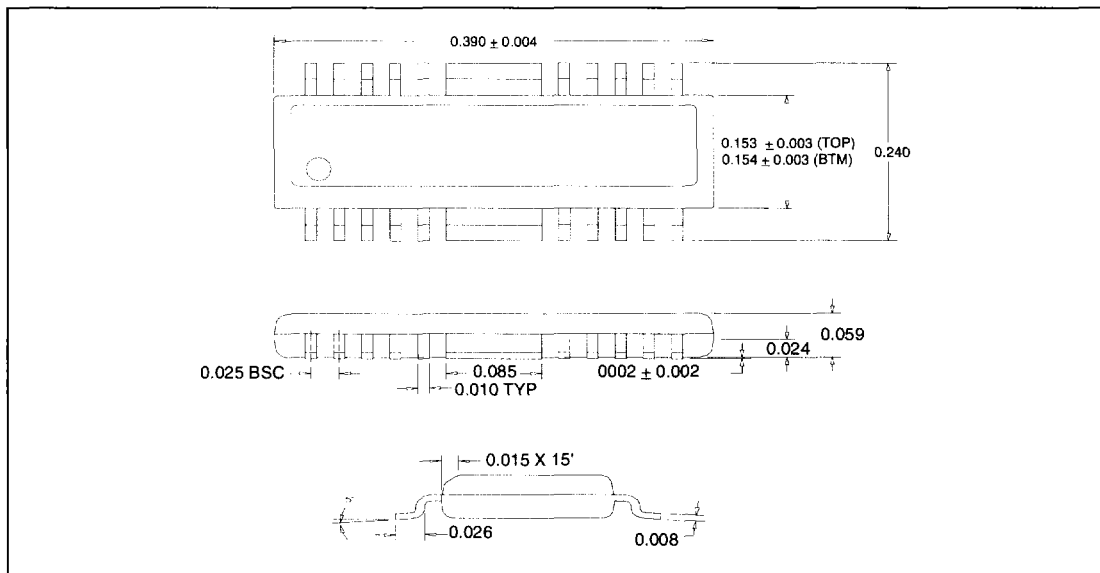

PIN	SIGNAL	DESCRIPTION
1	GND	RF and DC Ground
2	OUTPUT_2	RF output_2
3	GND	RF and DC Ground
4	V _{D3}	Drain 3 (5V)
5	GND	AC Ground
6,7,8,9	GND	RF and DC Ground (The "Batwing")
10	V _{D2}	Drain 2 (5V)
11	V _{D1}	Drain 1 (5V)
13	VCA	Voltage control attenuator (0, 3V)
14	GND	RF and DC Ground
15	GND	RF and DC Ground
16	RF _{IN}	RF power input
17	GND	RF and DC Ground
18	GND	AC Ground
19	V _{REF}	Control Attenuator Switch & Output Switch (3.6V)
20,21,22,23	GND	RF and DC ground ("BATWING")
24	VCSW	Control RF Output (selection of RF output between output 1 and output 2) (0 or 3 V)
25	GND	AC Ground
26	GND	RF and DC ground
27	OUTPUT 1	RF output_1
28	GND	RF and DC Ground

4. Electrical Circuit

