

Features

April 2006

- 12 10/100 Mbps Autosensing, Fast Ethernet ports with Reduced MII Interface
- Single Gigabit Ethernet port
 - Supports both GMII and integrated Physical Coding Sublayer with Ten Bit Interface (TBI) logic to interface directly with Gigabit transceivers
- Two-chip solution for 24+2 configuration
 - 32-bit wide bi-directional pipe at 100 MHz provides 6.4 Gbps pipe to connect two MDS213 chips
- Supports up to 6.548 Mpps system throughput using non-blocking architecture
- High performance Layer 2 packet forwarding and filtering at full wire speed.
- Very low latency through single store and forward at ingress port and cut-through switching at destination ports
- Port Trunking and Load Sharing for high bandwidth links between switches
- On-chip address lookup engine and memory for up to 2 K MAC addresses
- Parallel Flash interface for fast self initialization
- Supports packet filtering and port security
 - System wide filtering
 - Static MAC destination and source address filtering

Ordering Information

MDS213CG	456 Pin HSBGA	Trays
MDS213CG2	456 Pin HSBGA**	Trays

**Pb Free Tin/Silver/Copper

0°C to 70°C

- VLAN for multicast/broadcast filtering
- Protocol filtering
- Local port filtering
- Aging control for secure MAC addresses
- Provides 256-port and ID Tagged Virtual LANs (VLANs) 802.1Q
- ID Tagging Insertion/Extraction
- Supports IP Multicasting through IGMP Snooping
- XpressFlow Quality of Service (QoS), IEEE 802.1p, supports 4 Level transmission priorities, weighted fair queuing based packet scheduling, user mapping of priority levels and weights
- Full duplex Ethernet IEEE 803.2x flow control minimizes traffic congestion
- Supports back-pressure flow control for half duplex mode
- Flooding and Broadcasting control
- Link status and TX/RX activity through serial LED interface

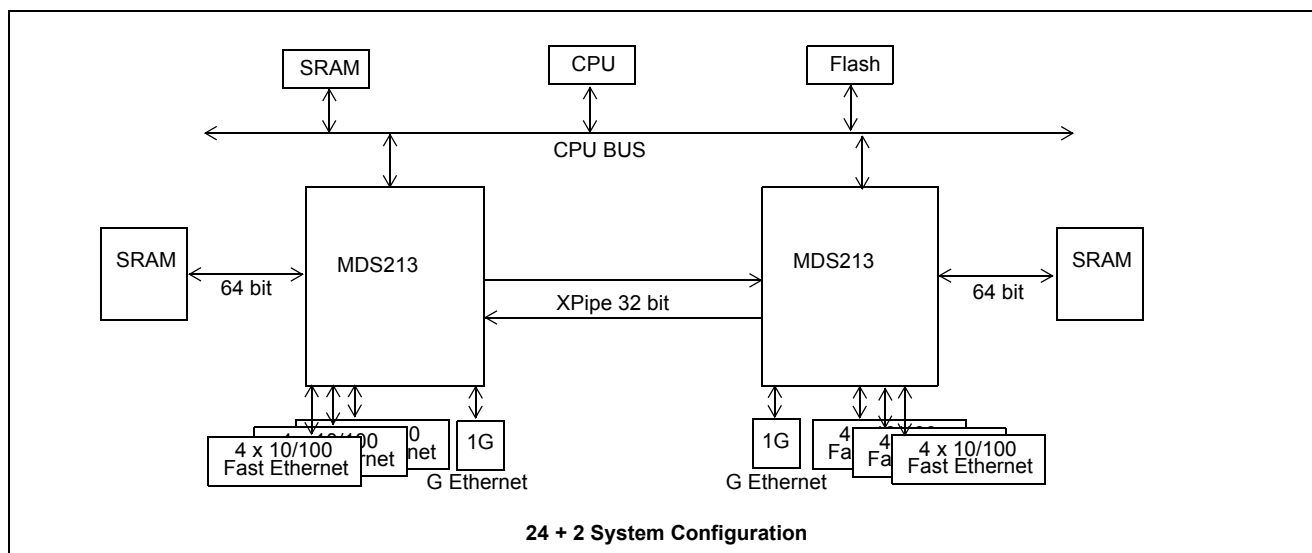
Figure 1 - 24 10/100Mbps + 2Gbps Port System Configuration

- Up to 64 K using management CPU memory
- Up to 16 K using external buffer memory
- Standard software modules available:
 - Browser, GUI, and text menu
 - IEEE 802.1d Spanning Tree Algorithm
 - SNMP management
 - Telnet for remote control console
 - Automatic Booting via TFTP Protocols.
 - Remote Monitoring (RMON) and storage for a management agent
 - IGMP for IP multicast
 - GVRP, GMRP
- Packaged in 456-Pin Ball Grid Array

Description

The Zarlink MDS213 is a 12-port 10/100 Mbps + 1 Gbps high-performance, non-blocking Ethernet switch with on-chip address memory and address lookup engine. A single chip provides 12 - 10/100 Mbps ports and 1 - 1000 Mbps port. The MDS213 can be utilized in both managed and unmanaged switching applications.

The 3.2 Gbps XPipe allows a high-speed connection between two MDS213 chips, providing a optimal, low-cost, workgroup switch with 24 10/100 Fast Ethernet ports and 2 Gigabit Ethernet ports.

In half-duplex mode, all ports support back pressure flow control to minimize the risk of losing data for long activity bursts. In full-duplex mode, IEEE 802.3x frame based flow control is used. With full-duplex capabilities, each Fast Ethernet ports supports 200 Mbps aggregate bandwidth connections, while the Gigabit Ethernet port supports 2 Gbps to desktops, servers, or other high-performance switches. The Physical Coding Sublayer is integrated on-chip with Ten Bit Interface (TBI) and this Physical Coding Sublayer can be bypassed when the GMII interface is used.

The MDS213 supports port trunking/load sharing on the 10/100 Mbps ports. Port trunking/load sharing can be used to group ports between interlinked switches for increased system bandwidth. Ports within a trunk must reside within a single MDS213, such that trunks may not be configured across two switches.

The on-chip address lookup engine supports up to 2 K MAC addresses and up to 256 IEEE 802.1Q Virtual LANs (VLAN). Each port may be programmed to recognize VLANs, and will transmit frames along with their VLAN Tags, for interoperability, to systems that support VLAN Tagging.

Each port independently collects statistical information using SNMP and the Remote Monitoring Management Information Base (RMON - MIB). Access to these statistical counter/registers are provided via the CPU interface. SNMP Management frames may be received and/or transmitted via the CPU interface and thus creates a complete network management solution.

The MDS213 utilizes cost effective, high performance, pipelined SBRAM to achieve full wire speed on all ports simultaneously. Data is buffered into memory, using 0-128 byte bursts, from the ingress ports, and transferred to an internal transmit FIFO, before being sent from the frame memory to the egress output ports. Extremely high memory bandwidth is therefore achieved, which allows each of the ports to be active without creating a memory bottleneck.

The MDS213 is fabricated with 2.5 V technology, where the inputs are 3.3 V tolerant and the outputs are capable of directly interfacing to Low-Voltage TTL levels. The Zarlink MDS213 is packaged in a 456-pin Ball Grid Array.

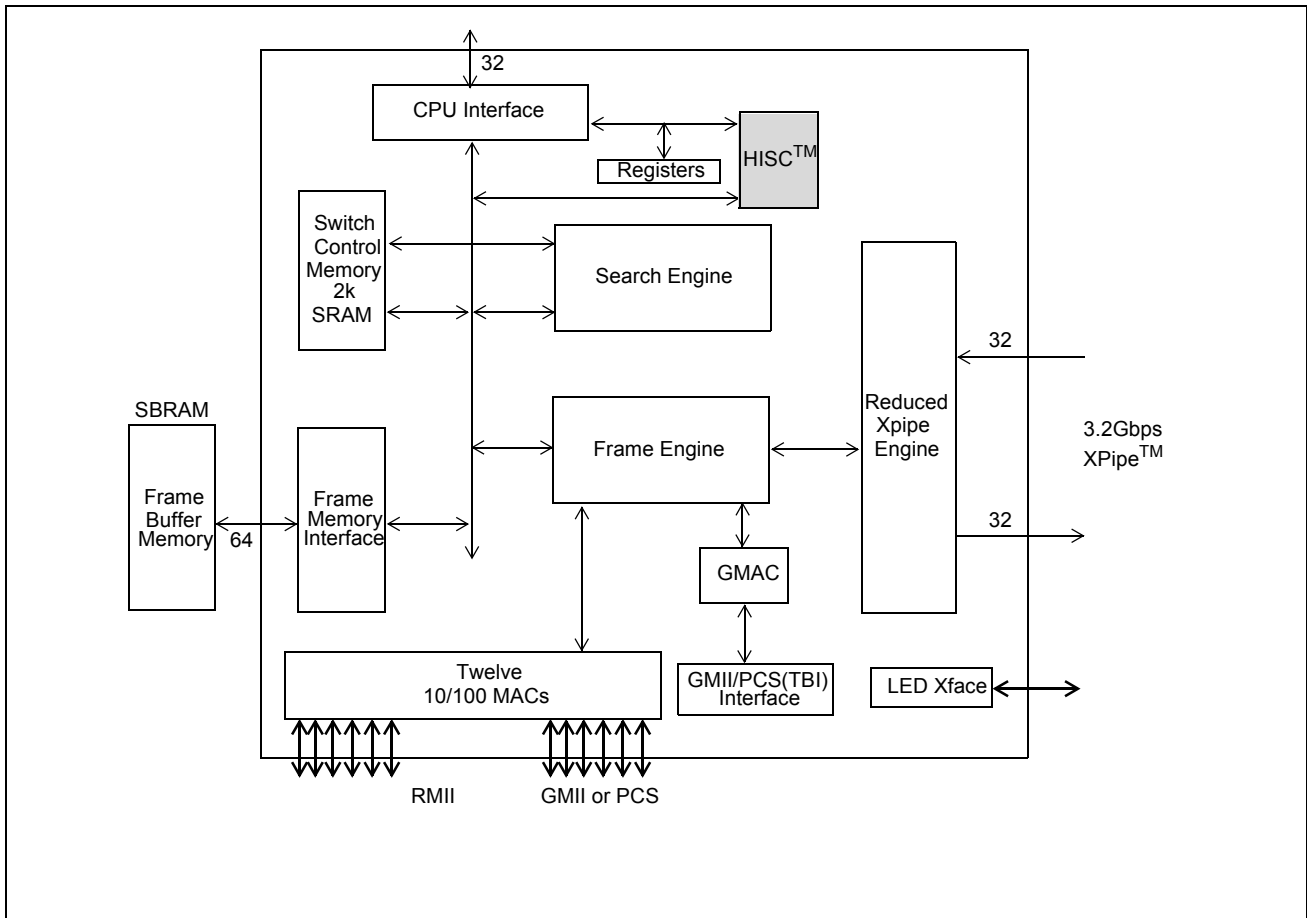

Figure 2 - System Block Diagram

Note:

All registers are 32-bit width.
 The Control Bus is 32-bits wide and the Memory Bus is 64-bits wide.
 The MDS213 contains 12 Fast Ethernet Ports.
 The LED interface has 3 output signals (1 data and 2 control).
 The XPipe is 32-bits wide.

Table of Contents

1.0 Ball Signal Descriptions and Assignments	11
1.1 Ball Signal Assignments	12
2.0 Ball-Signal Descriptions	17
3.0 The Media Access Control (MAC) and GIGABIT (GMAC)	24
3.1 MAC/GMAC Configuration	24
3.2 The Inter-frame Gap	24
3.3 Ethernet Frame Limits	24
3.4 Collision Handling and Avoidance	24
3.5 Auto-negotiation	25
3.6 VLAN Support	25
3.7 MAC Control Frames	25
3.8 Flow Control	25
3.8.1 Collision-Based Flow Control	26
3.8.2 IEEE 802.3x Flow Control	26
3.9 Frame Bursting	27
4.0 Frame Engine Description	27
4.1 Transmission scheduling	28
4.2 Buffer Management	28
5.0 Frame Buffer Memory	29
5.1 Frame Buffer Memory Configuration	29
5.2 Frame Buffer memory usage	30
5.2.1 Memory Allocation of a Managed System	30
5.2.2 Frame Data Buffers	31
5.2.3 Transmission Queues	31
5.2.4 Mailing List	31
5.2.5 VLAN Table	32
5.2.6 VLAN MAC Association Table	32
5.2.7 Unmanaged System Memory Allocation	32
5.3 The Frame Memory Interface	32
5.3.1 Local Memory Interface	32
6.0 Search Engine	33
6.1 Layer 2 Search Process	34
6.1.1 VLAN Unaware	34
6.1.2 VLAN Aware	34
6.2 Address and VLAN Learning	34
6.3 Flooding and Packet Control	35
6.4 Packet Filtering	35
6.5 Address Aging	35
6.6 IP Multicast	35
7.0 The High Density Instruction Set Computer (HISC)	36
7.1 Description	36
7.2 HISC architecture	36
7.3 HISC Operations	36
7.3.1 Resource Initialization	36
7.3.2 Resource Management	37
7.3.3 Switching Database Management	37
7.3.4 Send and Receive Frames for Management CPU	37
7.3.5 Communication Between HISC and Switching Hardware	37
7.3.6 Communication Between Search Engine and HISC	37
7.3.7 Communication Between HISC and Frame Engine	37
7.4 Communication Between Management CPU and HISC	37

Table of Contents

7.4.1 CPU-HISC Communication Using Queues	38
7.4.2 Mailbox	38
7.4.3 CPU-HISC MAIL	38
7.4.4 HISC-CPU Mail	38
8.0 The XPipe	38
8.1 XPipe Connection	38
8.2 XPipe Timing	39
9.0 Physical Layer (PHY) Interface	40
9.1 Reduced MII (RMII)	40
9.2 The Gigabit Media Independent Interface (GMII)	41
9.2.1 The MII Management Interface	41
9.2.2 MII Command and Status Registers	41
9.3 The Physical Coding Sublayer with Ten Bit Interface (TBI)	41
10.0 The Control Bus	42
10.1 External CPU Support	42
10.1.1 Power On/Reset Configuration	43
10.1.2 CPU Bus Clock Interface	43
10.1.3 Address And Data Buses	43
10.1.4 Bus Master	43
10.1.5 Input/Output Mapped Interface	43
10.1.6 Interrupt Request	44
10.2 Control Bus Cycle Waveforms	44
10.3 The CPU Interface in Unmanaged Mode	44
10.3.1 Arbiter	44
10.4 CPU Interface in Managed Mode	45
10.4.1 CPU Access	45
11.0 The LED Interface	46
11.1 LED interface	46
11.1.1 Function Description	47
11.1.2 Port Status	47
11.1.3 LED Interface Time Diagram	47
12.0 Data Forwarding Protocol and Data Flow	48
12.1 Data Forwarding Protocol	48
12.1.1 Frame Reception	48
12.1.2 Unicast Frame Forwarding	48
12.1.3 Multicast Frame Forwarding	49
12.2 Flow for Data Frame	49
12.2.1 Unicast Data Frame to Local Device	49
12.2.2 Unicast Data Frame to Remote Device	49
12.2.3 Multicast Data Frame	50
12.3 Flow for CPU Control Frame	50
12.3.1 CPU Transmitting Unicast CPU Frame	50
12.3.2 CPU Transmitting Multicast CPU Frame	50
12.3.3 CPU Receiving Unicast Frame	50
12.3.4 CPU Receiving Multicast frame	51
13.0 Port Mirroring	51
13.1 Features	51
13.2 Physical Pins	52
13.2.1 Setting Register For Port Mirroring	52
13.2.1.1 APMR- Port Mirroring Register	52
14.0 Virtual Local Area Networks (VLAN)	54

Table of Contents

14.1 Introduction	54
14.2 VLAN Implementation	54
14.2.1 Static Definitions of VLAN Membership	54
14.2.2 Dynamic Learning of VLAN Membership	54
14.2.3 Dynamic Learning of Remote VLAN	54
14.2.4 MDS213 Data Structures For VLAN Implementation	55
14.2.4.1 VLAN ID Table	55
14.2.4.2 VLAN MAC Table	56
14.2.4.3 VLAN Port Mapping Table (VMAP)	57
14.2.4.4 Port VLAN ID (PVID) Register	57
15.0 IP Multicast	57
15.1 Introduction	57
15.2 IGMP and IP Multicast Filtering	58
15.3 Implementation in MDS213	58
15.3.1 MCT Table	59
15.3.1.1 MCT Structure For Unicast Frame	59
15.3.2 MCT structure for IP Multicast Packet	59
16.0 Quality of Service (QOS)	60
16.1 Weighted Round Robin Transmission Strategy	60
16.2 Buffer Management Functions	60
17.0 Port Trunking	61
17.1 Unicast Packet Forwarding	61
17.2 Multicast Packet Forwarding	62
17.2.1 Select One Forwarding Port per Trunk Group	62
17.2.2 Blocking Multicast Packets Back to the Source Trunk	63
17.3 MAC Address Assignment	64
18.0 Register Definitions	64
18.1 Register MAP	64
18.2 Register definitions	68
18.2.1 Device Configuration Register	68
18.2.1.1 GCR - Global Control Register	68
18.2.1.2 DCR0 - Device Status Register	69
18.2.1.3 DCR1 - Signature, Revision & ID Register	69
18.2.1.4 DCR2 - Device Configuration Register	69
18.2.1.5 DCR3 - Interfaces Status Register	72
18.2.1.6 MEMP - Memory Packed Register	72
18.2.2 Interrupt Control Registers	73
18.2.3 Buffer Memory interface register	74
18.2.3.1 MWARS - Memory Write Address Register - Single Cycle	74
18.2.3.2 MRARS - Memory Read Address Register - Single Cycle	74
18.2.3.3 Address Registers For Burst Cycle	75
18.2.3.4 Memory Read/Write Data Registers	76
18.2.3.5 VTBP - VLAN ID Table Base Pointer	76
18.2.3.6 MBCR - Multicast Buffer Control Register	77
18.2.3.7 AMA - RAM Counter Block Access Register	77
18.2.3.8 Reserve Register 1	78
18.2.3.9 Reserve Register 2	78
18.2.4 Frame Control Buffers Management Register	78
18.2.4.1 FCBSL - FCB Queue	78
18.2.4.2 FCBST - FCB QUEUE - Buffer Low Threshold	78
18.2.4.3 BCT - (FCB) Buffer Counter Threshold	79
18.2.4.4 BCHL - Buffer Counter Hi-low Selection	79

Table of Contents

18.2.5 Queue Management Register	79
18.2.5.1 CINC - CPU Input Queue	79
18.2.5.2 COTQ - CPU Output Queue	80
18.2.6 Switching Control register	80
18.2.6.1 HPCR - HISC Processor Control Register	80
18.2.6.2 HMCL0 - HISC Micro-code Loading Port - Low	81
18.2.6.3 HMCL1 - HISC Micro-code Loading Port - High	81
18.2.6.4 MSOR Micro Sequence 0 Register	81
18.2.6.5 MSOR Micro Sequence 1 Register	81
18.2.6.6 Flooding Control Register	82
18.2.6.7 MCAT - MCT Aging Timer	82
18.2.6.8 Tpmxr – Trunk Port Mapping Table Index Register	83
18.2.6.9 TPMTD - Trunking Port Mapping Table Data Register	83
18.2.6.10 PTR - Pacing Time Regulation	83
18.2.6.11 MTCR - MCT Threshold & Counter Register	84
18.2.7 Link List Management	84
18.2.7.1 LKS - Link List Status Register	84
18.2.7.2 AMBX - Mail Box Access Port	84
18.2.7.3 AFML - Free Mail Box List Access Port	85
18.2.8 Access Control Function	85
18.2.8.1 AVTC - VLAN Type Code Register	85
18.2.8.2 AXSC - Transmission Scheduling Control Register	85
18.2.8.3 ATTL - Transmission Timing Control	86
18.2.9 MII Serial Management Channel	86
18.2.9.1 AMIIC - MII Command Register	86
18.2.9.2 AMIIS - MII Status Register	87
18.2.10 Flow Control Management	87
18.2.10.1 AFCRIA - Flow Control RAM Input Address	87
18.2.10.2 AFCRID0 - Flow Control RAM Input Data 0	88
18.2.10.3 AFCRID1 - Flow Control RAM Input Data 1	88
18.2.10.4 AFCR - Flow Control Register	88
18.2.10.5 AMAR[1:0] - Multicast Address Reg. For MAC Control Frames	89
18.2.10.6 AMCT - MAC Control Frame Type Code Register	89
18.2.10.7 ADAR [1:0] - Base MAC Address Registers	89
18.2.10.8 ADAOR0 - MAC Offset Address Register 0	90
18.2.10.9 ADAOR1 - MAC Offset Address Register 1	90
18.2.10.10 ACKTM - Timer For SOF Checking	91
18.2.10.11 AFCHT10 - Flow Control Hold Time Of 10Mbps Port	91
18.2.10.12 AFCHT 100 - Flow Control Hold Time Of 100Mbps Port	91
18.2.10.13 AFCHT1000 - Flow Control Hold Time of Giga Port	92
18.2.10.14 AFCOFT10 - Flow Control Off Time of 10Mbps PROT	92
18.2.10.15 AFCOFT100 - Flow Control Off Time of 100Mbps PORT	92
18.2.10.16 AFCOFT1000 - Flow Control Off Time of Giga Port	93
18.2.11 Access Control Function Group 2 (Chip Level)	93
18.2.11.1 APMR- PORT MIRRORING REGISTER	93
18.2.11.2 PFR - Protocol Filtering Register	93
18.2.11.3 THKM [0:7] - Trunking Forwarding Port Mask 0-7	94
18.2.11.4 IPMCAS - IP Multicast MAC Address Signature	95
18.2.11.5 IPMCMSK- IP Multicast MAC Address Mask	96
18.2.11.6 CFCBHDL - FCB Handle Register For CPU Read	96
18.2.11.7 CPU Access Internal RAMs (Tables)	96
18.2.11.8 CPUIRCMD - CPU Internal RAM Command Register	97

Table of Contents

18.2.11.9 CPUIRDAT - CPU INTERNAL RAM DATA REGISTER	98
18.2.11.10 CPUIRRDY - Internal Ram Read Ready For CPU	100
18.2.11.11 LEDR- LED Register	100
18.2.12 Ethernet MAC Port Control Registers	100
18.2.12.1 ECR0 - ECR0 - MAC Port Control Register	101
18.2.12.2 ECR1 - MAC Port Configuration Register	101
18.2.12.3 ECR2 - MAC Port Interrupt Mask Register	103
18.2.12.4 ECR3 - MAC Port Interrupt Status Register	104
18.2.12.5 ECR4 - Port Status Counter Wrapped Signal.	105
18.2.12.6 PVID Register.	107
19.0 DC Electrical Characteristics	108
19.1 Absolute Maximum Ratings	108
19.2 DC Electrical Characteristics	108
20.0 AC Specifications	109
20.1 XPIPE Interface	109
20.2 CPU BUS Interface	111
20.3 Local SDRAM Memory Interface	113

List of Figures

Figure 1 - 24 10/100Mbps + 2Gbps Port System Configuration	1
Figure 2 - System Block Diagram	3
Figure 3 - Frame with Carrier Extension and Frame Bursting	26
Figure 4 - Frame Buffer Memory Configuration	29
Figure 5 - Memory Map of Managed System	31
Figure 6 - Memory Map of an Unmanaged System	32
Figure 7 - Typical Packet Header Information	33
Figure 8 - XPIPE System Block Diagram for the MDS213	38
Figure 9 - XPIPE Message Header	39
Figure 10 - Basic Timing Diagram of XPIPE	40
Figure 11 - CPU Interface Configuration in Managed Mode	42
Figure 12 - Control Bus Configuration in Unmanaged Mode	42
Figure 13 - Control Bus I/O	44
Figure 14 - Block Diagram of the Arbiter	45
Figure 15 - Little and Big Endian Byte Swapping Operation	45
Figure 16 - An Example of Byte Swapping	46
Figure 17 - LED Interface Connections	46
Figure 18 - Time Diagram of LED Interface	48
Figure 19 - Configuration of Mirror Port for MDS213	51
Figure 20 - Data Structure Diagram	55
Figure 21 - VLAN ID Table	55
Figure 22 - VLAN MAC Table	56
Figure 23 - Port Mapping Table	62
Figure 24 - Forwarding Port Mask Table	63
Figure 25 - Multicast Packet Forwarding Example	64
Figure 26 - XPIPE Interface - Output Valid Delay Timing	109
Figure 27 - AC Characteristics - CPU BUS Interface	111
Figure 28 - Local Memory Interface - Input Setup and Output Valid Delay Timing	113
Figure 29 - Port Mirroring Interface - Input Setup and Hold Timing	114
Figure 30 - Port Mirroring Interface - Output Delay Timing	114
Figure 31 - Reduce Media Independent Interface - Input Setup and Hold Timing	114
Figure 32 - Reduce Media Independent Interface - Output Delay Timing	114
Figure 33 - Input Setup and Hold Timing	117
Figure 34 - Output Valid Delay Timing	117
Figure 35 - LED Interface - Output Delay Timing	117

List of Tables

Table 1 - Type and Size of Memory Chips	29
Table 2 - Frame Buffer Memory Usage for Managed Mode	30
Table 3 - Frame Buffer Memory Usage For Unmanaged Mode	30
Table 4 - Summary Description of the Source and Target End Signals	39
Table 5 - RMI Specification Signals	41
Table 6 - Bootstrapping Options	43
Table 7 - LED Signal Names and Descriptions	47
Table 8 - MDS213 Register Map	65
Table 9 - Global Control Register	68
Table 10 - Device Status Register	69
Table 11 - AC Characteristics - XPipe Interface	110
Table 12 - AC Characteristics - CPU Bus Interface	112
Table 13 - AC Characteristics - Local SBRAM Memory Interface	113
Table 14 - AC Characteristics - Port Mirroring Interface	115
Table 15 - AC Characteristics - Reduced Media Independent Interface	115
Table 16 - AC Characteristics - Gigabit Media Independent Interface	116
Table 17 - AC Characteristics - Physical Media Attachment Interface	117
Table 18 - AC Characteristics - LED Interface	118

1.0 Ball Signal Descriptions and Assignments

	1	2	3	4	5	6	7	8	9	10	11	12	13	14	15	16	17	18	19	20	21	22	23	24	25	26		
A	AGND	L_A20	L_A19	L_A18	L_A17	L_A16	X_D029	X_D025	X_D020	X_D016	X_D013	X_D008	X_D005	X_D002	X_DC LKO	X_DI29	X_DI25	X_DI21	X_DI17	X_DI12	X_DI08	X_DI04	X_DI02	P_CS#	P_REP_Q1	P_GN TC		
B	Reserved	Reserved	L_A18	L_A14	L_A10	L_A5	X_D030	X_D026	X_D021	X_D018	X_D014	X_D010	X_D004	X_D003	X_FC0	X_DI28	X_DI23	X_DI20	X_DI16	X_DI11	X_DI07	X_DI03	X_DC LKI	Reserved	NC	NC		
C	AVDD	Reserved	Reserved	L_A17	L_A13	L_A6	X_D031	X_D028	X_D024	X_D019	X_D015	X_D012	X_D006	X_D001	X_D031	X_DI27	X_DI22	X_DI18	X_DI14	X_DI10	X_DI06	X_DI01	Reserved	P_REP_QC	P_BRD_Y#	P_BL AST		
D	L_D4	L_D1	L_CLK	NC	L_A16	L_A12	L_A7	L_A3	X_D027	X_D023	X_D017	X_D011	X_D007	X_DE NO	X_DI30	X_DI24	X_DI19	X_DI15	X_DI09	X_DI05	X_DI01	X_FC1	P_IN T	P_RD Y#	P_RS T#	P_A8		
E	L_D6	L_D5	L_D2	L_D0	GND	L_A15	VCC	L_A9	VDD	X_D022	VCC	X_D09	GND	X_D00	X_DI26	VCC	X_DI13	VDD	X_DI0	VCC	P_G NT1	GND	P_AD S#	P_A10	P_CL K	P_A7		
F	L_D11	L_D10	L_D8	L_D3	T_M ODE #																	P_R WC#	P_A9	P_A4	P_A3	P_A2		
G	L_D15	L_D14	L_D13	L_D7	VCC																	VCC	P_A6	P_D31	P_D30	P_D29		
H	L_D20	L_D18	L_D16	L_D12	L_D9																		P_A5	P_A1	P_D28	P_D26	P_D24	
J	L_D24	L_D23	L_D21	L_D7	VDD																		VDD	P_D27	P_D3	P_D21	P_D20	
K	L_D29	L_D27	L_D26	L_D22	L_D19																		P_D25	P_D22	P_D19	P_D18	P_D16	
L	L_WE0#	L_D31	L_D30	L_D28	VCC																		VCC	P_D17	P_D14	P_D13	P_D12	
M	L_BW0#	L_OE0#	L_W E1#	L_OE1#	L_D25																		P_D15	P_D10	P_D11	P_D9	P_D8	
N	L_BW3#	L_AD S#	L_B W2#	L_B W1#	S_CL K																		VDD	P_D7	P_D6	P_D4	P_D5	
P	L_BW5	L_B W4	L_B W7	L_B W6	VDD																			P_D0	T_D0	P_D1	P_D3	P_D2
R	L_D33	L_D34	L_D36	L_D35	L_D32																			T_D10	T_D4	T_D3	T_D2	T_D1
T	L_D37	L_D38	L_D39	L_D41	VCC																			VCC	T_D9	T_D7	T_D6	T_D5
U	L_D40	L_D42	L_D43	L_D46	L_D47																			T_D20	T_D15	T_D21	T_D1	T_D8
V	L_D44	L_D45	L_D48	L_D51	VDD																			VDD	T_D19	T_D16	T_D14	T_D13
W	L_D49	L_D50	L_D52	L_D56	L_D57																			PM_DO[1]	T_D25	T_D21	T_D18	T_D17
Y	L_D53	L_D54	L_D55	L_D61	VCC																			VCC	PM_DEN	T_D24	T_D23	T_D22
AA	L_D58	L_D59	L_D60	M_CL KI	M0_T XD0																			M12_RXD5	LE_# SYN CI	PM_DI[1]	PM_DI[0]	PM_DENI
AB	L_D62	L_D63	M0_T XEN	M0_C RS_D V	GND	M2_L NK	VCC	M3_CRS_DV	VDD	M5_L NK	VCC	M6_T XD1	M8_T XD0	GND	M9_T XD1	VCC	M10_RXD1	VDD	M11_TXD0	VCC	M12_TXER	GND	M_M DC	LE_# CLK O	LE_S YNC	PM_DO[0]		
AC	M0_L NK	M0_T XD1	M0_RM1_T XEN	M2_T XD1	M2_RXD1	M3_T XD1	M4_L NK	M4_RXD1	M5_T XD0	M6_T XEN	M7_L NK	M7_RM8_T RS_D V	M8_RM9_T XEN	M10_TXEN	M10_RXD0	M11_RXD1	M12_TXD0	M12_TXD3	M12_TXD6	M12_RXE R	M12_RXD4	M_M DIO	LE_DI	LE_D O				
AD	NC	M0_RM XD0	M1_T XD1	M2_T XEN	M2_C RS_D V	M3_T XD0	M4_T XEN	M4_CRS_DV	M5_T XD1	M5_RXD0	M6_C RS_D V	M7_T XEN	M7_RM8_T RS_D V	M9_T XD0	M9_RM10_T XD0	M10_TXD0	M11_TXEN	M11_RXD0	M12_LNK	M12_TXD2	M12_TXD7	M12_RXD V	M12_RXD3	M12_RXD7	NC	M12_RXD0		
AE	NC	M1_L NK	M1_RM2_T XD0	M3_L NK	M3_RXD1	M4_T XD1	M4_RXD0	M5_CRS_DV	M6_L NK	M6_RM7_T XD1	M8_L NK	M8_RM8_T XEN	M9_L NK	M9_RM10_T XD1	M10_TXD1	M11_LNK	M11_CRS_DV	M12_TXCL K	M12_TXD1	M12_TXD5	M12_TXEN	M12_RXD7	NC	M12_RXD1				
AF	M1_T XD0	M1_CM1_RS_DV	M2_RM2_T XD0	M3_T XEN	M3_RXD0	M4_T XD0	M5_T XEN	M5_RXD1	M6_T XD0	M6_RM7_T XD0	M7_T XD0	M7_RM8_T XD1	M8_T XD0	M8_RM9_T RS_DV	M10_LNK	M10_CRS_DV	M11_TXD1	M12_CRS COL	M12_TXD4	M12_TXD5	GREFM_CLK	M12_RXD6	NC	M12_RXD2				

GND	GND	GND	GND	GND	GND
GND	GND	GND	GND	GND	GND
GND	GND	GND	GND	GND	GND
GND	GND	GND	GND	GND	GND

- VCC = 3.3VDC for I/O (16 balls)
- VDD = 2.5VDC for core logic (10 balls)
- GND = Digital Ground for both VCC and VDD (42 balls)
- AVDD = 2.5VDC for Analog PLL (1 ball)
- AGND = Isolated Analog Ground for AVDD (1 ball)
- NC = No Connection
- Reserved = Do Not Connect

1.1 Ball Signal Assignments

Signal Name	Ball No.
NC	D4
RESERVED	C3
AGND	A1
RESERVED	B1
AVDD	C1
T_MODE#	F5
RESERVED	C2
L_CLK	D3
L_D0	E4
L_D1	D2
L_D2	E3
L_D3	F4
L_D4	D1
L_D5	E2
L_D6	E1
L_D7	G4
L_D8	F3
L_D9	H5
L_D10	F2
L_D11	F1
L_D12	H4
L_D13	G3
L_D14	G2
L_D15	G1
L_D16	H3
L_D17	J4
L_D18	H2
L_D19	K5
L_D20	H1
L_D21	J3
L_D22	K4
L_D23	J2

Signal Name	Ball No.
L_D24	J1
L_D25	M5
L_D27	K2
L_D26	K3
L_D28	L4
L_D29	K1
L_D30	L3
L_D31	L2
L_WE0#	L1
L_OEW#	M2
L_WE1#	M3
L_OE1#	M4
L_BW0#	M1
L_BW1#	N4
S_CLK	N5
L_BW2#	N3
L_BW3#	N1
L_ADS#	N2
L_BW4#	P2
L_BW5#	P1
L_BW6#	P4
L_BW7#	P3
L_D32	R5
L_D33	R1
L_D34	R2
L_D35	R4
L_D36	R3
L_D37	T1
L_D38	T2
L_D39	T3
L_D40	U1
L_D41	T4
L_D42	U2
L_D43	U3

Signal Name	Ball No.
L_D44	V1
L_D45	V2
L_D46	U4
L_D47	U5
L_D48	V3
L_D49	W1
L_D50	W2
L_D51	V4
L_D52	W3
L_D53	Y1
L_D54	Y2
L_D55	Y3
L_D56	W4
L_D57	W5
L_D58	AA1
L_D59	AA2
L_D60	AA3
L_D61	Y4
L_D62	AB1
L_D63	AB2
M0_LNK	AC1
M_CLKI	AA4
M0_TXEN	AB3
M0_TXD1	AC2
M0_TXD0	AA5
M0_CRSDV	AB4
M0_RXD1	AC3
M0_RXD0	AD2
NC	AD1
NC	AE1
M1_LNK	AE2
M1_TXEN	AC4
M1_TXD1	AD3
M1_TXD0	AF1

Signal Name	Ball No.
M1_CRS_DV	AF2
M1_RXD1	AF3
M1_RXD0	AE3
M2_LNK	AB6
M2_TXEN	AD4
M2_TXD1	AC5
M2_TXD0	AE4
M2_CRS_DV	AD5
M2_RXD1	AC6
M2_RXD0	AF4
M3_LNK	AE5
M3_TXEN	AF5
M3_TXD1	AC7
M3_TXD0	AD6
M3_CRS_DV	AB8
M3_RXD1	AE6
M3_RXD0	AF6
M4_LNK	AC8
M4_TXEN	AD7
M4_TXD0	AE7
M4_TXD0	AF7
M4_CRS_DV	AD8
M4_RXD1	AC9
M4_RXD0	AE8
M5_LNK	AB10
M5_TXEN	AF8
M5_TXD1	AD9
M5_TXD0	AC10
M5_CRS_DV	AE9
M5_RXD1	AF9
M5_RXD0	AD10
M6_LNK	AE10
M6_TXEN	AC11
M6_TXD1	AB12

Signal Name	Ball No.
M6_TXD0	AF10
M6_CRS_DV	AD11
M6_RXD1	AE11
M6_RXD0	AF11
M7_LNK	AC12
M7_TXEN	AD12
M7_TXD1	AE12
M7_TXD0	AF12
M7_CRS_DV	AC13
M7_RXD1	AD13
M7_RXD0	AF13
M8_LNK	AE13
M8_TXEN	AE14
M8_TXD1	AF14
M8_TXD0	AB13
M8_CRS_DV	AD14
M8_RXD1	AC14
M8_RXD0	AF15
M9_LNK	AE15
M9_TXEN	AC15
M9_TXD1	AB15
M9_TXD0	AD15
M9_CRS_DV	AF16
M9_RXD1	AE16
M9_RXD0	AD16
M10_LNK	AF17
M10_TXEN	AC16
M10_TXD1	AE17
M10_TXD0	AD17
M10_CRS_DV	AF18
M10_RXD1	AB17
M10_RXD0	AC17
M11_LNK	AE18
M11_TXEN	AD18

Signal Name	Ball No.
M11_TXD1	AF19
M11_TXD0	AB19
M11_CRS_DV	AE19
M11_RXD1	AC18
M11_RXD0	AD19
M12_CRS	AF20
M12_TXCLK/GP_TXCLK	AE20
M12_LNK/GP_LNK	AD20
M12_TXD0/GP_TXD9	AC19
M12_COL/GP_RXCLK1	AF21
M12_TXD1/GP_TXD8	AE21
M12_TXD2/GP_TXD7	AD21
M12_TXD3/GP_TXD6	AC20
M12_TXD4/GP_TXD5	AF22
M12_TXD5/GP_TXD4	AE22
REF_CLK	AF23
M12_TXD6/GP_TXD3	AC21
M12_TXD7/GP_TXD2	AD22
M12_TX_EN/GP_TXD1	AE23
M12_TX_ER/GP_TXD0	AB21
M12_RX_ER/GP_RXD0	AC22
M12_RX_DV/GP_RXD1	AD23
M12_RXD7/GP_RXD2	AE24
M12_RXD6/GP_RXD3	AF24
NC	AF25
NC	AE25
M12_RXD5/GP_RXD4	AA22
M12_RXD4/GP_RXD5	AC23
M12_RXD3/GP_RXD6	AD24
M12_RXD2/GP_RXD7	AF26
M12_RXD1/GP_RXD8	AE26
M12_RXD0/GP_RXD9	AD26
M12_RXCLK/GP_RSCLK0	AD25

Signal Name	Ball No.
M_MDIO	AC24
M_MDC	AB23
LE_DI	AC25
LE_CLKO	AB24
LE_SYNCI	AA23
LE_DO	AC26
LE_SYNCO	AB25
T_D31/PM_DO[1]	W22
T_D30/PM_DO[0]	AB26
T_D29/PM_DENO	Y23
T_D28/PM_DI[1]	AA24
T_D27/PM_DI[0]	AA25
T_D26/PM_DENI	AA26
T_D25	W23
T_D24	Y24
T_D23	Y25
T_D22	Y26
T_D21	W24
T_D20	U22
T_D19	V23
T_D18	W25
T_D17	W26
T_D16	V24
T_D15	U23
T_D14	V25
T_D13	V26
T_D12	U24
T_D11	U25
T_D10	R22
T_D9	T23
T_D9	T23
T_D8	U26
T_D7	T24
T_D6	T25

Signal Name	Ball No.
T_D5	T26
T_D4/BS_RDYOP	R23
T_D3/BS_PSD	R24
T_D2/BS_SWM	R25
T_D1/BS_RW	R26
T_D0/BS_BMOD	P23
T_D0	P22
P_D1	P24
P_D2	P26
P_D3	P25
P_D4	N25
P_D5	N26
P_D6	N24
P_D7	N23
P_D8	M26
P_D9	M25
P_D10	M23
P_D11	M24
P_D12	L26
P_D13	L25
P_D14	L24
P_D15	M22
P_D16	K26
P_D17	L23
P_D18	K25
P_D19	K24
P_D20	J26
P_D21	J25
P_D22	K23
P_D23	J24
P_D24	H26
P_D25	K22
P_D26	H25
P_D27	J23

Signal Name	Ball No.
P_D28	H24
P_D29	G26
P_D30	G25
P_D31	G24
P_A1	H23
P_A2	F26
P_A3	F25
P_A4	F24
P_A5	H22
P_A6	G23
P_A7	E26
P_CLK	E25
P_A8	D26
P_A9	F23
P_A10	E24
P_RST#	D25
P_RWC#	F22
P_ADS#	E23
P_RDY#	D24
P_BRDY#	C25
P_BLAST#	C26
NC	B26
NC	B25
P_INT	D23
P_REQC	C24
P_GNTC	A26
P_REQ1	A25
P_GNT1	E21
P_CSI#	A24
RESERVED	B24
RESERVED	C23
X_FCI	D22
X_DCLKI	B23
X_DNI	C22

Signal Name	Ball No.
X_DI0	E19
X_DI1	D21
X_DI2	A23
X_DI3	B22
X_DI4	A22
X_DI5	D20
X_DI6	C21
X_DI7	B21
X_DI8	A21
X_DI9	D19
X_DI10	C20
X_DI11	B20
X_DI12	A20
X_DI13	E17
X_DI14	C19
X_DI15	D18
X_DI16	B19
X_DI17	A19
X_DI18	C18
X_DI19	D17
X_DI20	B18
X_DI21	A18
X_DI22	C17
X_DI23	B17
X_DI24	D16
X_DI25	A17
X_DI26	E15
X_DI27	C16
X_DI28	B16
X_DI29	A16
X_DI30	D15
X_DI31	C15
X_FCO	B15
X_DCLKO	A15

Signal Name	Ball No.
X_DENO	D14
X_DO0	E14
X_DO1	C14
X_DO2	A14
X_DO3	B14
X_DO4	B13
X_DO5	A13
X_DO6	C13
X_DO7	D13
X_DO8	A12
X_DO9	E12
X_DO10	B12
X_DO11	D12
X_DO12	C12
X_DO13	A11
X_DO14	B11
X_DO15	C11
X_DO16	A10
X_DO17	D11
X_DO18	B10
X_DO19	C10
X_DO20	A9
X_DO21	B9
X_DO22	E10
X_DO23	D10
X_DO24	C9
X_DO25	A8
X_DO26	B8
X_DO27	D9
X_DO28	C8
X_DO29	A7
X_DO30	B7
X_DO31	C7
L_A3	D8

Signal Name	Ball No.
L_A4	A6
L_A5	B6
L_A6	C6
L_A7	D7
L_A8	A5
L_A9	E8
L_A10	B5
L_A11	A4
L_A12	D6
L_A13	C5
L_A14	B4
L_A15	E6
L_A16	D5
L_A17	C4
L_A18	B3
L_A19	A3
L_A20	A2
RESERVED	B2
VCC	E7
VCC	E11
VCC	E16
VCC	E20
VCC	G5
VCC	G22
VCC	L5
VCC	L22
VCC	T5
VCC	T22
VCC	Y5
VCC	Y22
VCC	AB7
VCC	AB11
VCC	AB16
VCC	AB20

Signal Name	Ball No.
VDD	E9
VDD	E18
VDD	J5
VDD	J22
VDD	N22
VDD	P5
VDD	V5
VDD	V22
VDD	AB9
VDD	AB18
GND	E5
GND	E13
GND	E22
GND	L11
GND	L12
GND	L13
GND	L14
GND	L15
GND	L16
GND	M11
GND	M12
GND	M13
GND	M14
GND	M15
GND	M16
GND	N11
GND	N12
GND	N13
GND	N14
GND	N15
GND	N16
GND	P11
GND	P12
GND	P13

Signal Name	Ball No.
GND	P14
GND	P15
GND	P16
GND	R11
GND	R12
GND	R13
GND	R14
GND	R15
GND	R16
GND	T11
GND	T12
GND	T13
GND	T14
GND	T15
GND	T16
GND	AB5
GND	AB14
GND	AB22

2.0 Ball-Signal Descriptions

The type of all pins is CMOS.

All input pins are 5 Volt tolerance.

All output pins are 3.3 CMOS drive.

CPU Bus Interface

Ball No(s)	Symbol	I/O	Description
G24, G25, G26, H24, J23, H25, K22, H26, J24, K23, J25, J26, K24, K25, L23, K26, M22, L24, L25, L26, M24, M23, M25, M26, N23, N24, N26, N25, P25, P26, P24, P22	P_D[31:0]	I/O-TS, U	Processor Data Bus Data Bit [31:0]
E24, F23, D26, E26, G23, H22, F24, F25, F26, H23	P_A[10:1]	Input /Out - U	Processor Address Bus Address Bit [10: 1]
D25	P_RST#	In-ST	Processor Bus - Master Reset
F22	P_RWC#	Input/Output-TS, U	Processor Bus - Read/Write Control Programmable polarity
E23	P_ADS#	Input/Output-TS, U	Processor Address Strobe
D24	P_RDY#	Out-OD- TS, U	Processor Bus - Data Ready
C25	P_BRDY#	Input- TS, U	Processor Bus - Burst Ready
C26	P_BLAST#	Input- TS, U	Processor Bus - Burst Last
D23	P_INT	Output	Processor Bus - Interrupt Request Programmable polarity
E25	P_CLK	Input	Processor Bus - Bus Clock
A24	P_CSI#	Input- U	Chip Select
C24	P_REQC	Input	Bus Request from CPU - Only using in debug mode when system is unmanaged.
A26	P_GNTC	Output	Bus Grant to CPU - Only using in debug mode when system in unmanaged.
A25	P_REQ1	Input/Output	Bus Request from secondary MDS213 to primary MDS213. Only using in debug mode when system is unmanaged.
E21	P_GNT1	Input/Output	Bus Grant to secondary MDS213 from primary MDS213. Only using in debug mode when system is unmanaged.

Note:

= Active low signal

Input = Input signal

In-ST = Input signal with Schmitt-Trigger

Output = Output signal (Tri-State driver)

Out-OD = Output signal with Open-Drain driver

I/O-TS = Input & Output signal with Tri-State driver

I/O-OD = Input & Output signal with Open-Drain driver

U = Internal weak pull-up

TS = Tri-state

ST = Schmitt Trigger

Frame Buffer Interface

Ball No(s)	Symbol	I/O	Description
AB2, AB1, Y4, AA3, AA2, AA1, W5, W4, Y3, Y2, Y1, W3, V4, W2, W1, V3, U5, U4, V2, V1, U3, U2, T4, U1, T3, T2, T1, R4, R3, R2, R1, R5, L2, L3, K1, L4, K2, K3, M5, J1, J2, K4, J3, H1, K5, H2, J4, H3, G1, G2, G3, H4, F1, F2, H5, F3, G4, E1, E2, D1, F4, E3, D2, E4	L_D[63:0]	I/O-TS, U	Frame Buffer - Data Bit [63:0]
A2, A3, B3, C4, D5, E6, B4, C5, D6, A4, B5, E8, A5, D7, C6, B6, A6, D8	L_A[20:3]	Output	Frame Buffer - Address Bit [20:3]
D3	L_CLK	Output	Frame Buffer Clock
N2	L_ADS#	Output	Frame Buffer Address Status Control
P3, P4, P1, P2, N1, N3, N4, M1	L_BW[7:0]#	Output	Frame Buffer Individual Byte Write Enable [7:0]
M3, L1	L_WE[1:0]#	Output	Frame Buffer Write Chip Select [1:0]
M4, M2	L_OE[1:0]#	Output	Frame Buffer Read Chip Select [1:0]
Ball No(s)	RMII ETHERNET ACCESS PORTS [11:0]		
AB23	M_MDC	Output	MII Management Data Clock - (Common for all RMII Ports [11:0])
AB24	M_MDIO	I/O-TS	MII Management Data I/O - (Common for all RMII Ports [11:0])
AA4	M_CLKI	Input	Reference Input Clock

Frame Buffer Interface (continued)

Ball No(s)	Symbol	I/O	Description
AC18, AB17, AE16, AC14, AD13, AE11, AF9, AC9, AE6, AC6, AF3, AC3	M[11:0]_RXD [1]	Input-U	Ports [11:0] - Receive Data Bit [1]
AD19, AC17, AD16, AF15, AF13, AF11, AD10, AE8, AF6, AF4, AE3, AD2	M[11:0]_RXD [0]	Input-U	Ports [11:0] - Receive Data Bit [0]
AE19, AF18, AF16, AD14, AC13, AD11, AE9, AD8, AB8, AD5, AF2, AB4	M[11:0]_CRS $\bar{D}V$	Input-U	Ports [11:0] - Carrier Sense and Receive Data Valid
AD18, AC16, AC15, AE14, AD12, AC11, AF8, AD7, AF5, AD4, AC4, AB3	M[11:0]_TXE N	Output	Ports [11:0] - Transmit Enable
AF19, AE17, AB15, AF14, AE12, AB12, AD9, AE7, AC7, AC5, AD3, AC2	M[11:0]_TXD[1]	Output	Ports [11:0] - Transmit Data Bit [1]
AB19, AD17, AD15, AB13, AF12, AF10, AC10, AF7, AD6, AE4, AF1, AA5	M[11:0]_TXD[0]	Output	Ports [11:0] - Transmit Data Bit [0]
AE18, AF17, AE15, AE13, AC12, AE10, AB10, AC8, AE5, AB6, AE2, AC1	M[11:0]_LNK	Input- ST, U	Ports [11:0] Link Status

GMII GIGABIT ETHERNET ACCESS PORT

Ball No(s)	Symbol	I/O	Description
AE24, AF24, AA22, AC23, AD24, AF26, AE26, AD26	M[12]_RXD[7: 0]	Input-U	Port [12] -- Receive Data Bit [7:0]
AD23	M[12]_RX_DV	Input-U	Port [12] -- Receive Data Valid
AC22	M[12]_RX_ER	Input- U	Port [12] -- Receive Error

GMII GIGABIT ETHERNET ACCESS PORT			
Ball No(s)	Symbol	I/O	Description
AF20	M[12]_CRS	Input- U	Port [12] - Carrier Sense
AF21	M[12]_COL	Input- U	Port [12] - Collision Detected
AD25	M[12]_RXCLK	Input- U	Port [12] - Receive Clock
AD22, AC21, AE22, AF22, AC20, AD21, AE21, AC19	M[12]_TXD[7: 0]	Output	Port [12] -- Transmit Data Bit [7:0]
AE23	M[12]_TX_EN	Output	Port [12] -- Transmit Data Enable
AB21	M[12]_TX_ER	Output	Port [12] -- Transmit Error
AE20	M[12]_TXCLK	Output	Port [12] - Gigabit Transmit Clock
AD20	M[12]_LNK	Input- ST, U	Port [12]--:Link Status
AF23	REF_CLK	Input- U	Port [12] - Gigabit Reference Clock
Ball No(s)	TBI GIGABIT ETHERNET ACCESS PORT [12]		
AD26, AE26, AF26, AD24, AC23, AA22,AF24, AE24, AD23, AC22	GP_RXD[9:0]	Input- U	Port [12] - TBI Receive Data Bit [9:0]
AF21	GP_RXCLK1	Input- U	Port [12] - TBI Receive Clock 1
AD25	GP_RXCLK0	Input- U	Port [12] - TBI Receive Clock 0
AC19, AE21, AD21, AC20, AF22, AE22, AC21, AD22, AE23, AB21	GP_TXD[9:0]	Output	Port [12] - TBI Transmit Data Bit [9:0]
AE20	GP_TXCLK	Output	Port [12] - TBI Gigabit Transmit Clock
AD20	GP_LNK	Input- ST, U	Port [12] - TBI Link Status
AF23	REF_CLK	Input - U	Port [12] - TBI Gigabit Reference Clock

XPIPE INTERFACE			
Ball No(s)	Symbol	I/O	Description
B23	X_DCLKI	Input	XPipe Data Clock Input
C22	X_DENI	Input	XPipe Data Enable Input
D22	X_FCI	Input	XPipe Flow Control Input

XPIPE INTERFACE			
Ball No(s)	Symbol	I/O	Description
C15, D15, A16, B16, C16, E15, A17, D16, B17, C17, A18, B18, D17, C18, A19, B19, D18, C19, E17, A20, B20, C20, D19, A21, B21, C21, D20, A22, B22, A23, D21, E19	X_DI[31:0]	Input	XPipe Data Input Bits [31:0]
A15	X_DCLKO	Output	XPipe Data Clock Output
B15	X_FCO	Output	XPipe Control Output
D14	X_DENO	Output	XPipe Data Enable Output
C7, B7, A7, C8, D9, B8, A8, C9, D10, E10, B9, A9, C10, B10, D11, A10, C11, B11, A11, C12, D12, B12, E12, A12, D13, C13, A13, B13, B14, A14, C14, E14	X_DO[31:0]	Output	XPipe Data Output Bit [31:0]
PORT MIRRORING			
AA26	PM_DENI	Input- TS, U	Port Mirroring Data Enable Input
AA25, AA24	PM_DI [1:0]	Input- TS, U	Port Mirroring Input Data Bit [1:0]
Y23	PM_DENO	Output	Port Mirroring Data Enable Output
AB26, W22	PM_DO[1:0]	Output	Port Mirroring Output Data Bit [1:0]
TEST FACILITY (sharing pins with other functions and for Testing purpose only)			
F15	T_MODE#	I/O-TS, U	Test Pin - Set Mode upon Reset, and provides test status output.

XPIPE INTERFACE			
Ball No(s)	Symbol	I/O	Description
W22, AB26, Y23, AA24, AA25, AA26, W23, Y24, Y25, Y26, W24, U22, V23, W25, W26, V24, U23, V25, V26, U24, U25, R22, T23, U26, T24, T25, T26, R23, R24, R25, R26, P23	T_D[31:0]	Output	Test Output
LED INTERFACE			
AC25	LE_DI	Input- U	LED Serial Data Input Stream
AA23	LE_SYNC#	Input- U	LED Input Data Stream
AB24	LE_CLKO	Output	LED Serial Interface Output Clock
AC26	LE_DO	Output	LED Serial Data Output Stream
AB25	LE_SYNCO#	Output	LED Output Data Stream

SYSTEM CLOCK, POWER AND GROUND PINS			
Ball No(s)	Symbol	I/O	Description
N5	S_CLK	Input	System Clock at 100 MHz
E9, E18, J5, J22, N22, P5, V5, V22, AB9, AB18	VDD	Power	+2.5 Volt DC Supply
E7, E11, E16, E20, G22, L22, T22, Y22, AB20, AB16, AB11, AB7, Y5, T5, L5, G5	VCC	Power	+3.3 Volt DC Supply

SYSTEM CLOCK, POWER AND GROUND PINS			
Ball No(s)	Symbol	I/O	Description
E5, E13, E22, L11, L12, L13, L14, L15, L16, M11, M12, M13, M14, M15, M16, N11, N12, N13, N14, N15, N16, P11, P12, P13, P14, P15, P16, R11, R12, R13, R14, R15, R16, T11, T12, T13, T14, T15, T16, AB5, AB14, AB22	VSS	Power Ground	Ground
C1, C1	AVDD[1:0]	Analog Power	Used for the PLL
A1, A1	AVSS[1:0]	Analog Ground	Used for the PLL
BOOTSTRAP PINS			
P23	BS_BMOD	Input	CPU Bus mode Must be set to 0
R26	BS_RW	Input	CPU Read/Write Control Polarity Selection Default=1 0=R/W#; 1=W/R#
R25	BS_SWM	Input	Switch mode: Default=1 0=Managed mode 1= Unmanaged
R24	BS_PSD	Input	Primary Device Enable Pin Default=1 0=Secondary 1=Primary
R23	BS_RDYOP	Input	Option of merge the P_RDY# and P_BRDY# as one pin Default=1 0=Merged pin 1=Separated pins

Note:

= Active low signal

Input = Input signal

In-ST = Input signal with Schmitt-Trigger

Output = Output signal (Tri-State driver)

Out-OD = Output signal with Open-Drain driver

I/O-TS = Input & Output signal with Tri-State driver

I/O-OD = Input & Output signal with Open-Drain driver

U = Internal weak pull-up

TS = Tri-state

ST = Schmitt Trigger

3.0 The Media Access Control (MAC) and GIGABIT (GMAC)

The MDS213 MAC/GMAC contains twelve Fast Ethernet MACs and one Gigabit Ethernet MAC, defined by the IEEE Standard 802.3 CSMA/CD. Each Fast Ethernet MAC is connected to a Physical Layer (PHY) via the Reduced Media Independent Interface (RMII), and the Gigabit Ethernet MAC is connected to a PHY via the Gigabit Media Independent Interface (GMII) or the Ten Bit Interface (TBI). The MAC/GMAC sublayer ("MAC/GMAC") consists of a Transmit and Receive section and is responsible for data encapsulation/decapsulation. Data encapsulation/decapsulation involves framing (frame alignment and frame synchronization), handling source and destination addresses, and detecting physical medium transmission errors. The MAC/GMAC also manages half-duplex collisions, including collision avoidance and contention resolution (collision handling). The MDS213 includes an optional MAC Control sublayer ("MAC Control") used for IEEE Flow Control functions.

During frame transmission, the MAC transmit section encapsulates the data by prepending a preamble and a Start of Frame Delimiter (SFD), inserts a destination and source address, and appends the Frame Check Sequence (FCS) for error detection. In VLAN aware switches, the MAC/GMAC inserts, replaces, or removes VLAN Tags from these frame formats based on instructions from the Search Engine. When necessary, the MAC/GMAC regenerates the Frame Check Sequence and performs "padding" for frames less than 64 bytes.

During frame reception, the MAC receive section verifies that the CRC is valid, de-serializes the data, and buffers the frame into the Receive FIFO. The MAC/GMAC then signals the Frame Engine, using Receive Direct Memory Access (RxDMA), that data is available in the FIFO and is ready for storage.

3.1 MAC/GMAC Configuration

MAC/GMAC operations are configured through the global Device Configuration Register (DCR2) and/or the MAC/GMAC Control and Configuration Registers (ECR0, ECR1), defined in the Register Definition Section of the MDS213 data sheet. The default settings for Autonegotiation, flow control, frame length, and duplex mode may be changed and configured by the user on a per-port basis, either in hardware or software.

3.2 The Inter-frame Gap

The Inter-frame Gap (IFG), defined as 96 bit times, is the interval between successive Ethernet frames for the MAC/GMAC. Depending on traffic conditions, the measurement reference for the IFG changes. If a frame is successfully transmitted without a collision, the IFG measurement starts from the de-assertion of the Transmit Enable (TXEN) signal. However, if a frame suffers a collision, the IFG measurement starts from the deassertion of the Carrier Sense (CRS) signal.

3.3 Ethernet Frame Limits

A legal Ethernet frame size, defined by the IEEE specification, must be between 64 and 1518 bytes, referring to the packet length on the wire. For transmitting or forwarding frames whose data lengths do not meet the minimum requirements, the MAC/GMAC appends extra bytes (padding) from the PAD field. Frames, longer than the maximum length may either be forwarded or discarded, depending on the register configuration. Although the MAC/GMAC may be configured to forward oversized frames in the Device Configuration Register (DCR2), the frame buffers' maximum size of 1536 bytes cannot be exceeded. For VLAN Aware systems, the maximum frame size is increased from 1518 bytes to 1522 bytes to accommodate the 4-byte VLAN Tag.

3.4 Collision Handling and Avoidance

In half duplex mode, if multiple stations on the same network attempt to transmit at the same time, interference could occur causing a collision. The MAC/GMAC monitors the Carrier Sense (CRS) signal to determine if the medium is available before attempting to transmit data. If the transmission medium is busy, the MAC/GMAC defers (delays) its own transmissions to decrease the load on the network. This is called collision avoidance.

If a collision occurs, after the first 64 bytes of data, the MAC/GMAC ceases data transmission and sends the jam sequence to notify all connected nodes of a collision. This jam sequence will persist for 32 bit times. The jam sequence is a 32 bit predetermined pattern used to notify other nodes that there is a collision on the network.

If a collision occurs during preamble generation, or within the first 64 bytes, the transmitter waits until the preamble is completed and then "backs off" (that is, stops transmitting) for a specific period (defined by the IEEE 802.3 Binary Exponential Backoff Algorithm) before sending the jam sequence and rescheduling transmission. A frame with a size no less than 96 bits (64 bits of preamble and 32 bits of jam pattern), is sent to guarantee that the duration of the collision is long enough to be detected by the transmitting ports involved.

3.5 Auto-negotiation

The default value of the MDS213 MAC/GMAC enables Auto-negotiation. The default value is over written if the PHY lacks the ability to support Auto-negotiation, which is ascertained through its respective management interface, RMII/GMII. The Auto-negotiation process detects the different modes of operation (i.e. speed selection, duplex mode) supported by the system at the other end of the link segment. Upon power on/reset, the PHY generates a special sequence of fast link pulses (FLPs) to begin Auto-negotiation. The MDS213 MAC/GMAC, supporting Auto-negotiation, reads the results from status register in the PHY (10/100 mode) or in the PCS submodule (PCS Giga mode).

3.6 VLAN Support

Virtual Local Area Networks (VLANs) assemble a group of independent ports (and/or MAC addresses) to communicate as if they were on the same physical LAN segment, without being restricted by the physically connected hardware. The ports are logically grouped together by VLAN Identifiers (VLAN IDs). The MDS213 implements a MAC Address-based classification that associates each VLAN ID with its MAC address in the Switch Database Memory (SDM) for purposes of aging out, or replacing, old VLANs.

The MDS213 MAC/GMAC recognizes VLAN-Tagged frame formats. During transmission, the MAC/GMAC inserts (or extracts) the 4-byte VLAN Tag and regenerates the Frame Check Sequence for the transmitted frame. VLAN support requires an increase in the maximum legal frame size, which is set in the Device Configuration Register (DCR2), from 1518 to 1522 bytes. During transmission, if the MAC/GMAC is required to remove the VLAN Tag from a 64-67 byte Rx frame, the MAC/GMAC will append extra bytes (pad) to form a 64 byte frame.

3.7 MAC Control Frames

MAC Control Frames, as defined by the IEEE, are used for specific control functions within the MAC Control sublayer "MAC Control." Similar to data frames, control frames are also encapsulated by the CSMA/CD MAC, meaning that they are prepended by a Preamble and Start of Frame delimiter and appended by a Frame Check Sequence. These frames may be distinguished from other MAC frames by their length/type field identifier (88.08h). The control functions are distinguished by an opcode contained in the first two bytes of the frame. Upon receipt, MAC control parses the incoming frame and determines, by looking at the opcode and the MAC address, whether it is destined for the MAC (a data frame) or for a specific function within MAC Control. After performing the specified functions, the MDS213 discards all MAC control frames it receives, regardless of the port configuration. These control frames are not forwarded to any other port and are not used to learn source addresses.

3.8 Flow Control

Flow control reduces the risk of data loss in the event a long burst of activity causes the MDS213 to saturate the buffer memory with backlogged frames. The MDS213 supports two types of Flow Control: Collision-based for half-duplex mode and IEEE 802.3x Flow Control for full duplex mode. In both cases, the MDS213 recognizes congestion by constantly monitoring available frame buffer memory. When the amount of free buffer space has been depleted, the MDS213 initiates the flow control mechanism appropriate to the current mode of operation. Setting the Flow Control (FC_Enable) bit in the MAC Port Configuration Register (ERC1) turns this operation on, thereby initiating PAUSE frames or applying backpressure flow control when necessary

3.8.1 Collision-Based Flow Control

Collision-based Flow Control, also referred to as Backpressure Flow Control, inhibits frame reception for ports operating in half-duplex mode by "jamming" the link. When the free buffer space drops below a user-defined buffer memory threshold, the MDS213 sends a jam sequence to all non transmitting ports, after approximately eight bytes of payload data has been received, to generate a collision. The jam sequence is a predefined serial data stream sent to all ports to indicate that there has been a collision on the network. These ports will delay (defer) the transmission of data onto the network until the sequence has been completed.

3.8.2 IEEE 802.3x Flow Control

IEEE 802.3x Flow Control reduces network congestion on ports that are operating in full duplex mode using MAC Control PAUSE frames and is managed by the Flow Control Management Registers. The full-duplex PAUSE operation instructs the MAC to enable the reception of frames with a destination address equal to a globally assigned 48-bit reserved multicast address of 01-80-C2-00-00-01. These PAUSE frames are subsets of MAC Control frames with an opcode field of 0x0001 and are used by the MAC Control to request that the recipient stops transmitting non-control frames for a specific period. The PAUSE Timer is loaded from the PAUSE frame and is started upon the reception of a PAUSE frame. It will request a length of time for which it wishes to inhibit data frame transmission.

In general, the IEEE standard allows pause frames longer than 64 bytes to be discarded or interpreted as valid. The MDS213 recognizes all MAC Control frames (PAUSE frames) between 64 and 1518 bytes long. Any PAUSE frames presented to the MAC outside of these parameters are discarded.

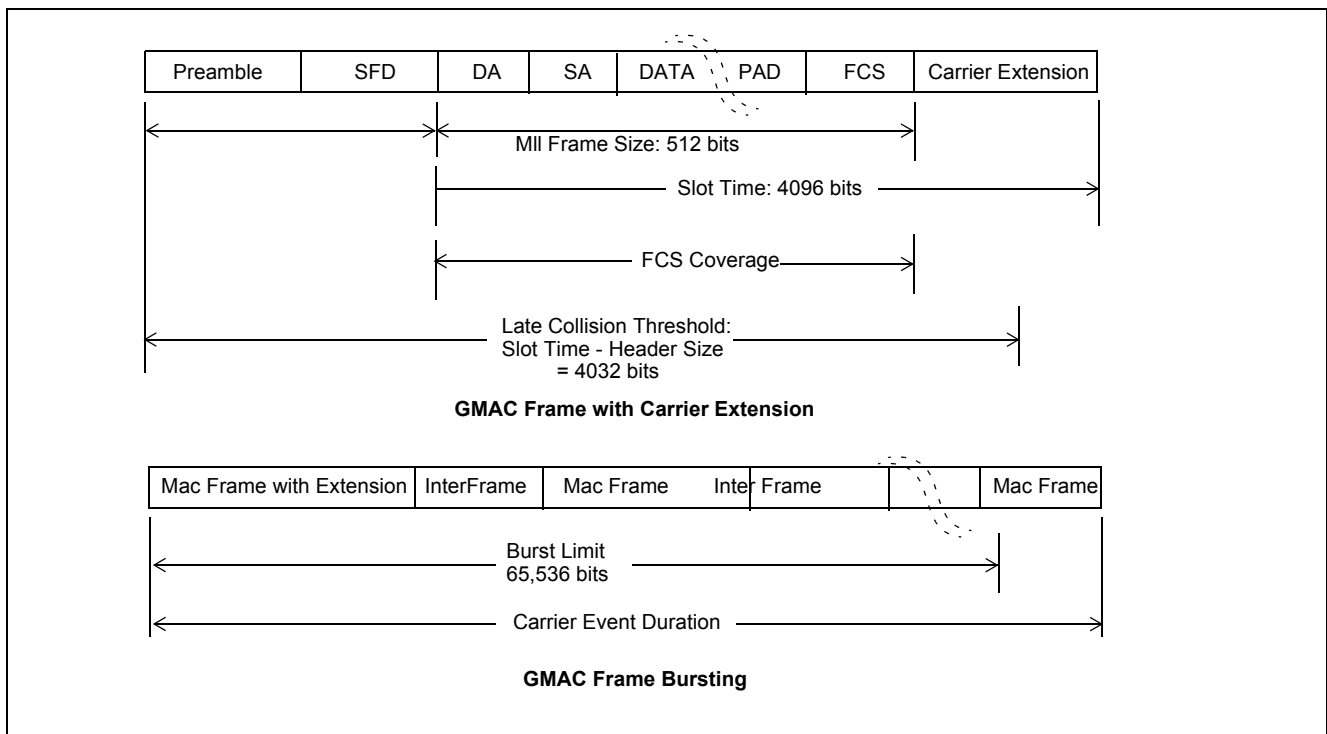

Figure 3 - Frame with Carrier Extension and Frame Bursting

3.9 Frame Bursting

At speeds faster than 100Mbps and operating in half-duplex mode, the MAC/GMAC can transmit a series of frames without relinquishing control of the transmission medium. This is called Frame Bursting. Frame Bursting is utilized when a frame must be extended to the length of the slot time. With Frame bursting, only the first transmitted frame requires extension. Once a frame has been successfully transmitted, the Transmit section may submit consecutive frames onto the medium without contention, provided that no idle conditions exist between frames (e.g., no Inter-Frame Gap). The transmitting MAC/GMAC inserts extension bits, detected and extracted by the receiving MAC/GMAC, into the Inter-frame space interval. The MAC/GMAC may continuously initiate burst frame transmission up to the burst limit of 65,536 bits.

4.0 Frame Engine Description

The Frame Engine is the heart of the MDS213. It coordinates all data movements, ensuring fair allocation of the memory bandwidth and the XPipe bandwidth.

When frame data is received from a MAC port, it is temporarily stored in the MAC Rx FIFO until the Frame Engine moves it to the chip's external memory one granule (128-byte-or-less fragment of frame data) at a time. The Frame Engine then issues the Search Engine a switching request that includes the source MAC address, the destination MAC address, and the VLAN tag. After the Search Engine has resolved the address, it transfers the information back to the Frame Engine via a switching response that includes the destination port and frame type (e.g., unicast or multicast).

When the destination port is idle, the frame data is fetched from the memory and is written to the destination port's MAC Tx FIFO. However, when the destination port is busy transmitting another frame, the Frame Engine writes a transmission job that includes a frame handle for future identification. These transmission jobs are stored in the destination port's transmission scheduling queues (TxQ). There are four TxQs per port, one for each priority class. When the destination port is ready, the Frame Engine selects the head-of-line job from a TxQ. The frame, specified by the job, will be fetched from the memory and will be written to the MAC Tx FIFO.

For unicast frames, if the destination device is local (i.e., the destination port is located in the same device), the Frame Engine writes a job into the destination port's transmission scheduling queue (TxQ). The Transmit DMA (TxDMA) moves the frame data to the MAC Tx FIFO once the frame's transmission job is selected for transmission.

If the destination device is remote (i.e., the destination port is located on another device, and can only be reached through the XPipe), all signaling between the two devices are sent as XPipe messages. The Frame Engine sends a scheduling request message via the XPipe to the destination port. This message asks the remote Frame Engine to write a job into the destination port's TxQ. When that job is selected, the remote Frame Engine sends a data request message via the XPipe to the local Frame Engine. Reception of a data request message triggers the forwarding engine module to forward the frame data to the destination port, one granule at a time through the XPipe until the end of file (EOF) safely arrives at the remote port's MAC Tx FIFO.

For multicast frames, the process is slightly different. The Frame Engine uses the VLAN index, which is part of the search result, to identify the destination ports. For local destination ports, the Frame Engine writes a job to each port's TxQ. When a transmission job is selected, the TxDMA moves data from the memory to the MAC Tx FIFO. Multicast frame data is sent multiple times, until all local destination ports' requests are satisfied.

For a VLAN that includes remote destination ports, the multicast frame data is forwarded once through the XPipe and then stored in the remote device's memory. The remote Frame Engine processes this multicast frame as if it came from a local port.

A frame is stored in a Frame Data Buffer (FDB) until it is transmitted. FDBs are external, located in a MDS213's frame buffer memory. To keep track of per-frame control information, the Frame Engine maintains one Frame Control Buffer (FCB) per frame. FCBs are internal. Since the Frame Engine does not access the external memory for frame control information, this conserves memory bandwidth for better performance.

As a frame lives through its lifecycle, its status is updated in the FCB. The FCB also contains vital frame information, such as destination port and length. There is a one-to-one correspondence between the FCB and the FDB: FCB#274 contains information about the frame stored in FDB#274. An FCB/FDB pair is called a "frame buffer," or simply a "buffer." The number 274 is called the handle or the buffer handle. The Frame Engine takes care of the distribution and the releasing of buffers. It also keeps buffer counters to ensure no port or single type of traffic occupies too many buffers.

The receiving DMA (RxDMA) moves frame data from the MAC RxFIFO to the FDB. Before the RxDMA writes frame data into the FDB, it must obtain a free buffer handle from the buffer manager. A free buffer handle points to an empty or released frame buffer, ensuring that no stored frame data will get overwritten. After the EOF has been safely stored in the FDB, it writes the frame information to the FCB and issues a switching request to the Search Engine. If the frame is found to be bad (e.g., bad CRC), the buffer handle will be released and nothing will be written to the Search Engine or the FCB. This returns the buffer back to circulation and the frame is discarded.

The RxDMA can fail to obtain a free buffer handle for two reasons. All buffers are currently occupied, or the received frame is a multicast frame and the multicast buffer quota is exhausted. In either case, the RxDMA will discard the frame, without getting a handle. If set, the register bit DCR2[26], IPMC, enables IP multicast privileges. If enabled, the RxDMA discards regular multicast frames if the multicast forwarding FIFOs occupancy exceeds the programmable threshold (see register MBCR[21:20], MCTH). An IP multicast frame is discarded only when the multicast frame's forwarding FIFO is full.

4.1 Transmission scheduling

There are four transmit scheduling queues (TxQ) per port, one for each priority. When a port is ready to transmit, when the previous frame finished transmitting, the port control module notifies the Frame Engine. The Frame Engine selects one TxQ out of the four priority queues, depending on the frame's arrival time and weighted round robin state (refer to the QoS chapter for more detail). It reads an entry from the selected transmission scheduling queue, and if the source port of the selected frame is local, a transmission request is issued to the local TxDMA module. If, on the other hand, the source port is remote, the data request message is forwarded across the XPipe and subsequently arrives at the forwarding engine.

The four transmit scheduling queues per output port allows the Frame Engine to perform weighted round robin (WRR) to provide quality of service (QoS). The Search Engine classifies the frames into four internal priorities, Q0, Q1, Q2, and Q3, in decreasing priority. The 802.1p priority bits are mapped to the internal priorities by a programmable mapping, accessible via register AVTC. The user can program the queue weights via register AXSC, and thereby control the relative rates of the four internal-priority tagged frames.

The maximum TxQ lengths are programmable from 128 entries to 1024 entries per queue. 52 TxQs are located in the external memory. The maximum queue lengths and the base memory addresses are accessible by the register group {CPUIRCMD, CPUIRDAT, CPUIRRDY}, under type QCNT.

4.2 Buffer Management

The buffer manager is responsible for the free handle allocation, buffer usage monitoring, buffer release and FCB access control. Free handles point to buffers that are not occupied by a frame. These free buffers can be allocated to a new frame received by the RxDMA. When the Frame Engine is done processing a frame, its handle is released to the free handle pool.

The free handle pool must be initialized via the register group CPUIRCMD, CPUIRDAT, CPUIRRDY, type BMCT, before device operation. The Buffer Manager Control Table (BMCT) is the pool of free handles. At reset, the BMCT is empty. Prior to device operation, free handles must be written to the BMCT. The user must write the integers {0,1,2,3, ... K-1} to the BMCT one-at-a-time, where K is the maximum number of buffers. The value of K depends on the external memory size and partition, and it can be 128, 256, 512, or 1024.

If all buffers are used, no more frames can enter the device. The Frame Engine keeps buffer counters that limit the number of buffers occupied by frames destined for each output port. If a buffer counter exceeds a programmable

threshold, its associated output port is "blacklisted." Entering frames destined to this output port are discarded, until the counter goes below the threshold. This threshold is programmed via registers BCT and BCHL. These counters prevent complete depletion of buffers due to an overloaded port, thus allow frames destined for non-congested ports to enter the system. This effectively avoids head-of-line blocking.

The Frame Engine also keeps a buffer counter for multicast traffic types. The buffers occupied by incoming multicast frames are limited. This prevents multicast frames from blocking unicast ones from entering the system. The threshold for multicast traffic types is programmed via register MBCR.

5.0 Frame Buffer Memory

5.1 Frame Buffer Memory Configuration

The MDS213 system utilizes external SRAM for its Frame Buffer Memory configuration, where the size of memory supported is ½ MB, 1 MB and 2 MB configurations. The following table shows four memory configuration examples for the MDS213 system.

SRAM Type	One Bank		Two Bank	
	Address	Size	Address	Size
64 Kx32	L_A[18:3]	½MB	L_A[19:3]	1M
128 Kx32	L_A[19:3]	1MB	L_A[20:3]	2M

Table 1 - Type and Size of Memory Chips

The following figure shows the connections between the Frame Buffer Memory and the MDS213 for one-bank and two-bank memory configurations.

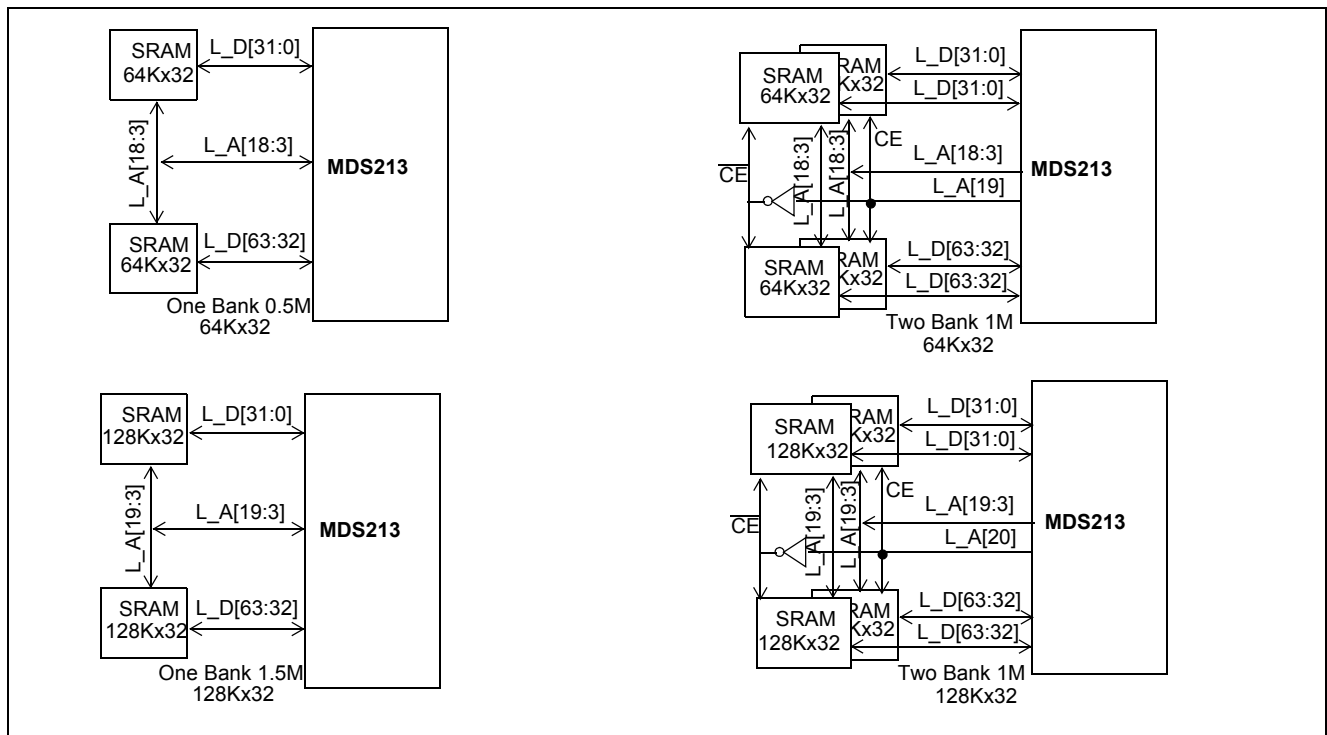

Figure 4 - Frame Buffer Memory Configuration

5.2 Frame Buffer memory usage

The MDS213 supports two switching modes: managed and unmanaged. The following tables describe Frame Buffer Memory usage for managed and unmanaged modes of operation, respectively.

Description	Unit Size	Unit Count	Total Size	Reference by
Frame Data Buffer (FDB)	1.5 Kbytes	256 to 1 K	384 K bytes to 1.5 M bytes	FE ¹
Transmission Queue	4 bytes x 128 K to 4 bytes x 1 K	52 (4 level priority)	26 Kbytes to 208 Kbytes (at 4 level priority)	FE ¹
CPU/HISC Mailing List	32 Bytes to 64 Bytes (Programmable)	128 to 1K	4 K bytes to 32 Kbytes (at 32 Bytes each)	CPU, HISC & SE ¹
VLAN Table	8 bytes x 4 K	1	32 Kbytes	HISC & SE ¹
VLAN MAC Table	8 bytes to 32 bytes x 2 K	1	16 Kbytes to 64 Kbytes	HISC & SE ¹

Note: FE: Frame Engine, SE: Search Engine

Table 2 - Frame Buffer Memory Usage for Managed Mode

Description	Unit Size	Unit Count	Total Size	Reference by
Frame Data Buffer (FDB)	1.5 Kbytes	256 to 1 K	384 K bytes to 1.5 M bytes	FE
Transmission Queue	4 bytes x 128 to 4 bytes x 1 K	52 (4 level priority) 13 (1 level priority)	26 Kbytes to 208 Kbytes (at 4 level priority)	FE
HISC Mailing List	32 Bytes to 64 Bytes (Programmable)	128 to 1 K	4 K bytes to 32 Kbytes (at 32 Bytes each)	HISC & SE

Note: FE: Frame Engine, SE: Search Engine

In unmanaged mode, the system does not support VLAN features. Thus, VLAN related tables are not required.

Table 3 - Frame Buffer Memory Usage For Unmanaged Mode

5.2.1 Memory Allocation of a Managed System

In a managed system, the Frame Buffer Memory is partitioned into five segments: Frame Data Buffers (FDBs), Transmission Queues, Mailing Lists, VLAN, and MCT VLAN Association Tables.

5.2.5 VLAN Table

The VLAN Table associates the ports to their respective VLANs, using the VLAN ID. The table contains 4 K VLAN entries, where each entry contains 8 bytes of information. The size of the VLAN Table is 32 KB (4Kx8B). The base address of the VLAN Table is specified by the VIDB in the VTBP bit [5:0].

Note: The VLAN Table must be located at the 32 K boundary.

5.2.6 VLAN MAC Association Table

The VLAN MAC Table (VLAN MCT) associates each port's MAC address with its respective VLAN. The Table comprises of 2048 entries, one entry per MAC address. Each VLAN MAC entry is mapped to each bit associated with a VLAN specified by the VLAN Index. The size of the Table is defined by two bits in the VTBP register and depends on the system configuration (e.g., the number of VLANs supported in the system). Each entry may consist of 256, 128 or 64 bits (one bit per VLAN). The total size of the VLAN MAC Table may be 16, 32 or 64 KB. The VMACB field in the register VTBP specifies the base address.

Note: The VLAN MAC Table must be located at the 16 K boundary.

5.2.7 Unmanaged System Memory Allocation

Since an unmanaged system does not support VLAN operation, the VLAN and VLAN MAC tables are not required. Only the Frame Data Buffers, Transmission Queues, and HISC Mailing Lists are allocated in system memory.

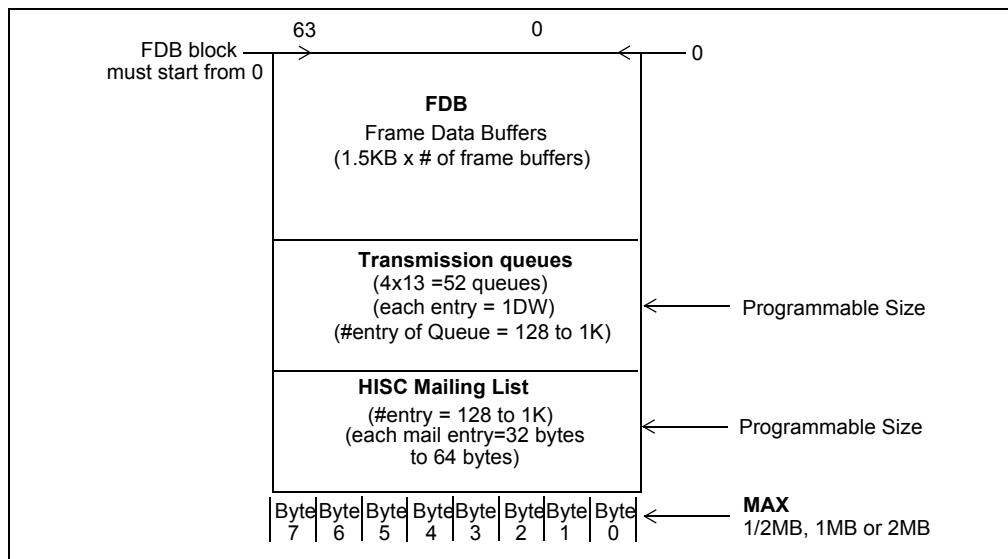

Figure 6 - Memory Map of an Unmanaged System

5.3 The Frame Memory Interface

5.3.1 Local Memory Interface

Each frame within the MDS213 is allocated its own buffer memory. The primary function of the Frame Buffer Memory is to provide a temporary buffering space for both received and transmitted frames, as well as frames waiting in the transmission queue. The actual usage depends on the frame type to be transmitted, either unicast or multicast and the relationship between the source and destination ports. The buffer memory also, contains other control structures including stacks, queues, other control tables. The buffer memory may be configured for 128 K,

256 K, 512 K, 1024 K Bytes depending on the application of the system designer. The MDS213 local memory interface supports up to 2 M bytes of SRAM.

6.0 Search Engine

The Search Engine is responsible for determining the destination information for all packet traffic that enters the MDS213. The results from all address or VLAN searches are passed to the Frame Engine to be forwarded, or on to the HISC block for further processing. The result messages to either the Frame Engine or the HISC provide all the needed information to allow the destination block to process the packet.

The Search Engine has been optimized for high throughput searching, utilizing the integrated Switch Database Memory (SDM). The internal SDM contains up to 2 k MAC Control Table (MCT) entries. These MCT entries are searched utilizing one of four Hashing algorithms that can be selected. This provides the capability of changing the search hashing to optimize the hash tables based on the traffic patterns in a given network. For example, if a company gets all their Network Interface Cards (NIC) from one vendor, then the source and destination MAC addresses will have common fields. This can lead to inefficient search hashing. With 4 different hash selections that utilize different parts of the address fields, and can be 8, 9, or 10 bits in length, the hashing algorithm that works best for a user's network can be selected (by testing each hash algorithm).

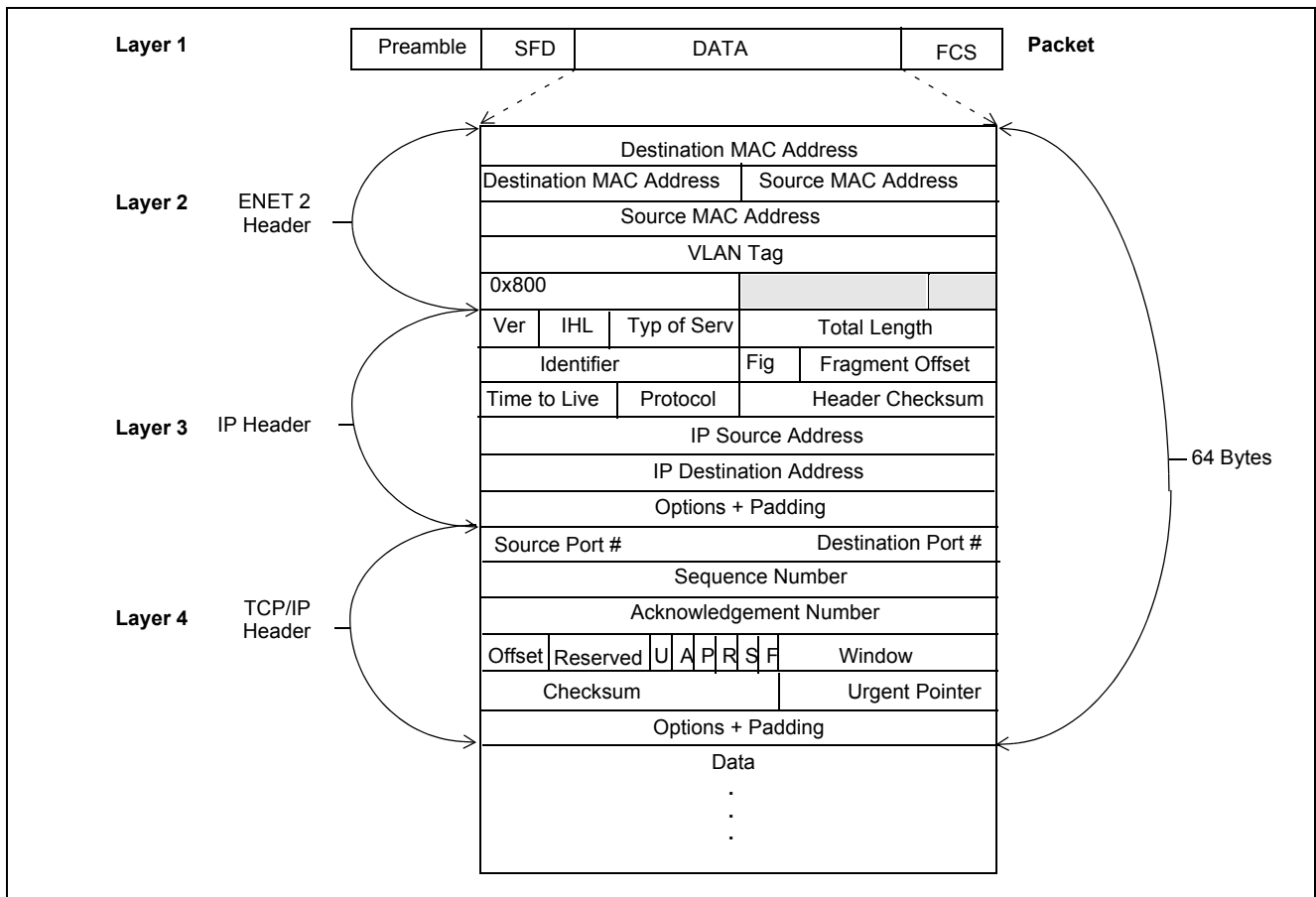

Figure 7 - Typical Packet Header Information

The search process begins when the Frame Engine transfers the first 64 bytes of a packet header to the Search Engine. These bytes are parsed to extract the information needed to perform the search for the MCT entries that match the source and destination MAC address, generate the search hash keys, lookup VLAN membership, and other packet status information.

6.1 Layer 2 Search Process

When the MDS213 is in either a "forwarding" state (able to forward packets) or a "learning" state (able to learn new addresses), the Search Engine is capable of performing address searches. The search process begins when packet header information is transferred to the Search Engine from the Frame Engine.

The Search Engine first checks to determine if the MDS213 is configured to support Virtual Local Area Networks (VLAN). If VLANs are enabled, the Search Engine will search for both the destination MAC address, to get destination resolution information, and the source MAC address, to get the port's VLAN membership and verify the validity of the port's VLAN membership. If VLANs are disabled, the Search Engine will search for the destination and source MAC addresses but will not do a VLAN table check.

6.1.1 VLAN Unaware

When VLANs are not enabled or configured, the Search Engine will search the internal switch database memory for an MCT that matches the destination MAC address. When a match is found, the Search Engine will check to ensure that the destination address is not to be filtered before sending a search result message back to the Frame Engine to start the packet forwarding process. At the same time, a search for the MCT that matches the source MAC address is also performed. If no match is found for the source address, then the source MAC address needs to be learned.

6.1.2 VLAN Aware

When VLANs are enabled and configured, the Search Engine will begin searching for the destination MCT and the source MCT. If a matching MCT is found for the source address, then no learning is required, and the Search Engine will check the VLAN membership of the source port. If the source port is a member of the VLAN, and the destination port is also a member of the VLAN, then a normal response message will be passed to the Frame Engine. If the source port is not a valid member of the VLAN, or the destination port is not a member of the VLAN, then the Search Engine will decide to forward the packet or drop the packet depending upon a user defined configuration. Then it will send a message to the HISC to allow the HISC to resolve the issue.

6.2 Address and VLAN Learning

Address learning can be performed by either the HISC or the Search Engine and can be enabled or disabled. The global learning control is set in the Device Configuration Register (DCR2). The Global Learning Disable (GLN) bit controls whether learning is active or disabled, and can be set during initial power up configuration, or by an external CPU before it begins modifying the SDM. It is necessary for an external CPU to disable learning before updating or modifying MCT entries. This prevents the internal learning process from modifying MCT entries without the CPU's knowledge.

When learning is globally enabled, by the Search Engine not finding a match to a source address search, it can create a new MCT with the necessary information, and then notify the HISC that a new address has been learned. If the Search Engine request queue becomes 3/4th full, the Search Engine will ignore address learning until the request queue is less full. In that case, packets are forwarded as usual, and a message is sent to the HISC requesting that the HISC learn the new address. If the Search Engine request queue is too full, and the HISC request queue is full, then no learning will take place.

When two MDS213 chips are connected, and configured to operate with synchronized MCT entries, the HISC processor has the ability to send a request to the Search Engine, instructing it to learn a new address received from the other MDS213. The HISC processor can also use this method to make simple edits to the MCT entries for port changes (i.e., source MAC address is now connected to a different port on the MDS213).

6.3 Flooding and Packet Control

Packets, for which there are no matching destination MCT entries, are by default flooded to all output ports. This can result in broadcast storms and cause the number of flooded packets to increase rapidly. The MDS213 provides the user a means for setting a level of flooding, by providing a Flooding Control Register (FCR). The FCR allows the user to define a time base (100us to 12.8ms) during which packet flooding at each output port will be counted. Three separate flood control fields allow the user to specify flooding limits for:

- Unicast to Multicast (flooded) packets per source port
- Unicast to CPU packets per chip
- Multicast to CPU packets per chip

During the time base period, three separate counters at each port count the number of packets meeting the flood control types. Once a counter exceeds the allowed quantity, the Search Engine will then discard the packet and any other packets of that type that enter the port during the remainder of the time base period. When the time base period is completed, the three flood counters at each port are reset, and the counting process starts over.

The flooding control register is global for setting the limits on all register ports, but the individual ports have separate counters to keep track of the number of flooded.

6.4 Packet Filtering

Packet filtering occurs during the address search phase. For static source or destination MAC address filtering, there is a corresponding bit in the MCT entry that tells the Search Engine that the source or destination packet is to be filtered.

When a match is found to a destination MAC address search, the "Destination Filter" (D) field in the MCT is checked to determine if the destination address is to be filtered. If "D" is asserted, the Search Engine discards the packet by sending a message to the Frame Engine telling it to release the Frame Control Buffer (FCB) where the packet has been stored in the frame buffer memory. The packet thereby deleted from memory.

When a match is found to a source MAC address search, the "Source Filter" (S) field in the MCT is checked to determine if the source address is to be filtered. If "S" is asserted, then the Search Engine discards the packet by sending a message to the Frame Engine telling it to release the FCB for the packet.

6.5 Address Aging

Entries in the MCT database are removed if they have not been used within a user selectable time frame. This aging process is handled by inspecting a single MCT entry during each clock period. If the entry is valid and subject to aging, an aging flag in the MCT entry is cleared. If the aging flag is already set to zero during the inspection, an aging message is sent to the HISC processor to delete and free up the aged MCT entry. Each time an MCT entry is matched by way of a Search Engine, source search process, the aging flag is asserted to restart the aging process for that entry.

Some entries may be static and not subject to aging. These MCT entries have a status field that identifies them as being static, and will therefore always have their aging flag asserted. The network manager, using Zarlink Management software, establishes static entries during a switch configuration session.

6.6 IP Multicast

The Search Engine supports the ability of the MDS213 to provide IP Multicast by identifying Internet Group Multicast Protocol (IGMP) packets when parsing the packet header information provided by the Frame Engine. IGMP packets are identified when the destination MAC address is 01-00-5E-xx-xx-xx, the Protocol field has the value of 2, and the source IP address is 224.0.0.x.

When an IGMP packet is identified, the Search Engine searches for the source address MCT entry, and then passes a message to the HISC to allow it to setup or tear down the IP Multicast session. IP Multicast sessions are treated as VLANs and use one of the 256 regular VLAN entries.

7.0 The High Density Instruction Set Computer (HISC)

7.1 Description

The High Density Instruction Set CPU (HISC) is specifically designed to implement highly efficient management functions for the MDS213 switching hardware, minimizing the management activity intervention during frame processing. The HISC services management requests based on an event-driven approach. Management requests can be generated from either the management CPU or the switching hardware. The HISC is also designed with a powerful instruction set and dedicated hardware interfaces for packet processing and transmission to provide high performance packet transfers between the CPU interface and the switching hardware.

7.2 HISC architecture

The HISC is designed with an advanced pipeline architecture that combines the advantages of both RISC and VLIW architectures. The HISC core combines a rich instruction set with 88 general-purpose registers and support for multiple-way jump. The 88 registers are divided into three parts, eight common general-purpose registers and two banks of 40 registers for two different task contexts. All registers are directly connected to the Arithmetic Logic Unit (ALU), allowing two independent registers to be accessed in one single instruction execution. Each HISC instruction may have up to three sub-instructions, which can be executed in one clock cycle. The resulting architecture is more code efficient while achieving throughputs up to ten times faster than a CISC processor or up to three times faster than a RISC processor. For a MDS213 running at 100 MHz, the HISC can produce up to 300MIPs processing power.

7.3 HISC Operations

With an event-driven operation model, upon the request from either the Search Engine or external management CPU, the HISC dynamically manages and maintains the Switch Database including MAC address entries, VLAN and MAC-VLAN Association Tables. The HISC also provides an external management CPU a high-speed data communication interfaces, so management packets can be transmitted to or received from the network.

In general, the service request is received from one of four different sources:

- Messages from the management CPU
- Requests from the switching hardware (Search Engine)
- Real time clock
- Interrupts to the management CPU

The HISC performs the following major operations:

- Resource initialization
- Resource management
- Switching database management
- Send and receive frames for management CPU

7.3.1 Resource Initialization

The HISC initializes all internal data structures including the mail box and switching database data structures, which are used by the management CPU, HISC and switching hardware.

7.3.2 Resource Management

The HISC can enforce a replacement policy when the number of free data structure for new MAC address entries is lower than the predefined threshold.

7.3.3 Switching Database Management

One of the major management tasks required of the HISC is to create, delete, and modify MAC address entries upon requests from the Search Engine or management CPU. Generally, the Search Engine performs the learning of new MAC addresses identified in the packet streams. For a single MDS213 system, the HISC simply informs the management CPU regarding the newly learned MAC addresses.

The HISC may also create, delete, or modify the MAC address entries based on the requests from the management CPU. For a multi-MDS system, the HISC is response for synchronizing the switching databases. In addition to the MAC address entries, the HISC also maintains the following database information required for switching:

- Create, delete and modify VLAN table in the switching database.
- Create, delete and modify MAC VLAN table in the switching database.
- Create, delete and modify IP Multicast entries in the switching database.

7.3.4 Send and Receive Frames for Management CPU

The HISC delivers BDPU, SNMP and other frames to and from the management CPU. In unmanaged mode, the HISC also responds to interrupts destined to the management CPU.

7.3.5 Communication Between HISC and Switching Hardware

High-speed communication channels are required to provide fast message deliveries between the HISC and switching hardware. Two high-performance FIFOs provide the required communication channels. They are between the HISC and the Frame Engine, and between the HISC and Search Engine.

7.3.6 Communication Between Search Engine and HISC

The first high-speed FIFO is used by the Search Engine to send messages, management requests or received packets, to the HISC. Whenever a message is sent to the FIFO, the HISC is notified of the new event. Each message may contain up to two command codes, processed by the HISC sequentially. The HISC can also request from the Search Engine to do operations such as search or learn via a HISC I/O interface. After processing the requests, the Search Engine then sends the response back to the HISC via the FIFO.

7.3.7 Communication Between HISC and Frame Engine

The second high-speed FIFO is used by the HISC for sending data transfer requests to the Frame Engine. Whenever a packet-forwarding request is received from the management CPU, the HISC forwards the request to the Frame Engine via the FIFO. To alleviate the workload of the management CPU, certain management packets can be processed by the HISC, and then forwarded to the Frame Engine for transmission via the FIFO.

7.4 Communication Between Management CPU and HISC

The HISC serves as an intermediary communication channel between the switching hardware and the external management CPU. There are two communication mechanisms provided for messages exchanged between the management CPU and HISC.

7.4.1 CPU-HISC Communication Using Queues

The first communication mechanism is a pair of Input and Output Queues between HISC and management CPU. The management CPU input/output queue is a very efficient mechanism for a single 32-bit data exchange between the HISC and management CPU. In general, a management frame, i.e., Bridged Data Protocol Units (BDPU), is forwarded directly from the HISC to the management CPU via the CPU Output Queue. Small management requests, less than 24 bits, are delivered to the HISC via the CPU Input Queue.

7.4.2 Mailbox

The second communication mechanism is a hardware mailbox that can support variable size messages, exchanged between the management CPU and the HISC. A major use of the mailbox is to exchange information required for updating the switching database.

7.4.3 CPU-HISC MAIL

When the management CPU sends a mail message to the HISC, the CPU acquires an address of a free mail from the free mail list (via register AFML). It then writes the mail content to the given memory address. Afterward, it sends the mail to the HISC via the Mailbox Access (AMBX) Register. Whenever a management mail message is received, an event is generated to inform the HISC to process the mail message.

7.4.4 HISC-CPU Mail

When a mail message arrives from the HISC, the mailbox hardware sends an interrupt, namely "Mail Arrive" (MAIL_ARR) to the CPU. The CPU can then access the mail via the Mailbox Access Register (AMBX). At this point, the CPU reads the mail handle and retrieves the contents of the mail from the AMBX Register.

8.0 The XPipe

The XPipe provides a high-speed link between systems utilizing two MDS213 devices. The XPipe incorporates a 32-bit-wide data pipe, with a high-speed point-to-point connections, and a full-duplex interface between devices. While operating at a 100MHz, this interface can provide 3.2G bits per second (Gbps) of bandwidth per pipe in both directions.

8.1 XPipe Connection

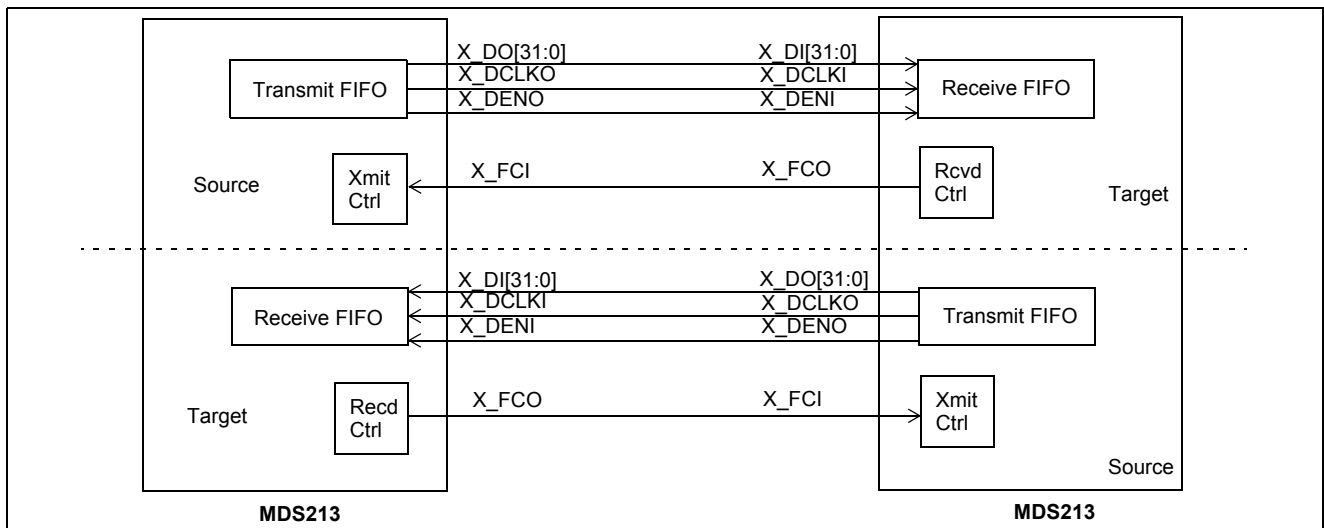

Figure 8 - XPipe System Block Diagram for the MDS213

The XPipe interface employs 32 data signals and three control signals for each direction. The pin connections between two MDS213 devices are depicted in Figure 8. These 32 data signals form a 32-bit-wide transmission data pipe that carries XpressFlow messages to and from the devices. The direction of all signals are from the source to the target device, except for the flow control signal, which sends messages in the opposite direction; from the target to the source. The three control signals consist of: a Transmit Clock signal, a Transmit Data Enable signal, and a Flow Control signal.

The Transmit Clock signal (X_DCLKO), provides a synchronous clock to sample the data signals at the target device. The source device provides the Transmit Data Enable signal (X_DENO) that envelops an entire XPipe message (including the Header and the Payload) and is used to identify the message boundary from the received data stream. The timing relationship between the data, clock, and data enable signals are described in the XPipe Timing (Section 10.2).

The Flow Control signal (X_FC) monitors the state of the receiving queue at the target end to prevent XPipe message loss. When the target end does not have enough space to accommodate an entire XPipe message, the target device sends a XOFF signal by driving the X_FCO signal to LOW. The source device will stop further transmission until the X_FCI signal asserts the XON state, which is an active HIGH (Refer to Table 4).

Signal Name		Description
Source End	Target End	
X_DO[31:0]	X_DI[31:0]	32-bit-wide Transmit Data Bus - Includes a XPipe Message Header and follows by the data payload
X_DCLKO	X_DCLKI	Transmit Clock - Synchronous data clock provided by the source end
X_DENO	X_DENI	Transmit Data Enable - Provided by the source end to envelop the entire XPipe message
X_FCI	X_FCO	Flow Control Signal- A flow control pin from the target end to signal the source end to active XON/XOFF.

Table 4 - Summary Description of the Source and Target End Signals

The XPipe Message Header provides the payload size, type of message, routing information, and control information for the XPipe incoming message. The routing information includes the device ID and port ID. The header size is dependent upon the message types and may be 2 to 4 words in length.

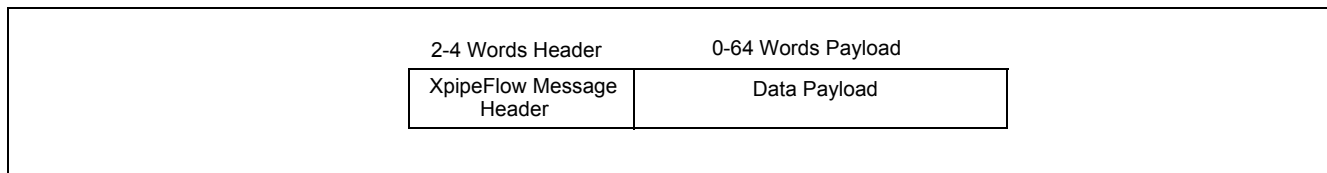

Figure 9 - XPipe Message Header

8.2 XPipe Timing

The source device generates the X_CLKO signal to provide a synchronous transmit data clock. The Receiver will then sample the data on the falling (negative) edge of the clock, as shown in Figure 10.

To identify the boundary between the XPipe messages and the data stream, the source device uses the X_DENO signal to envelop the entire XPipe message. That is, a rising (positive) edge at the beginning of the first double word

(4 bytes) and a falling (negative) edge at the beginning of the last double word of an XPipe message as shown in Figure 10.

Note: The negative edge does not occur at the end of the last double word, but instead, at the beginning of the last double word. This allows XPipe messages to be sent consecutively (back-to-back).

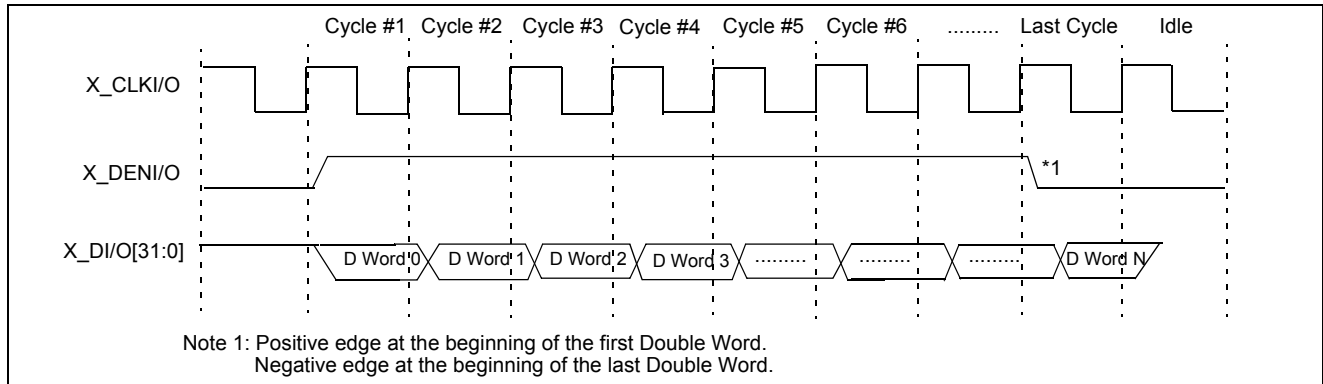

Figure 10 - Basic Timing Diagram of XPipe

9.0 Physical Layer (PHY) Interface

The Physical Layer Interface is designed to interface Zarlink chipsets to a variety of Physical Layer devices. Reduced Media Independent Interface (RMII) is used for 10/100 interfaces, while Gigabit connections can use either Gigabit Media Independent Interfaces (GMII) or Ten Bit Interface (TBI).

The chip ball names for the MAC use M as the first letter of the name, followed by their pin number, and then their function. For example, M1_RXD0 refers to Mac port 1, receive data 0 of the receive data pair.

9.1 Reduced MII (RMII)

The MDS213 implements the Reduced Media Independent Interface (RMII) signals, REF_CLK, CRS_DV, RXD [1:0], TX_EN, and TXD [1:0], defined in Section 5 of the RMII Consortium Specification. The purpose of this interface is to provide a low cost alternative to the IEEE 802.3u [2] MII interface. Under IEEE 802.3u [2] an MII comprised of 16 pins for data and control is defined. In devices incorporating many MACs or PHY interfaces such as switches, the number of pins can add significant cost as the port counts increase. Zarlink MDS213 offer 12 or 24 ports, in one or two devices respectively. At 6 pins per port and 1 pin per switch ASIC, the RMII specification saves 119 pins plus the extra power and ground pins to support those additional pins for a 12 port switch ASIC. Architecturally, the RMII specification provides for an additional reconciliation layer on either side of the MII but can be implemented in the absence of an MII. The management interface (MDIO/MDC) is assumed to be identical to that defined in IEEE 802.3u [2].

The RMII supports both 10 and 100 Mbps data rates across a two bit Transmit Data (TXD) path and a two bit Receive Data (RXD) path.

The RMII uses a single synchronous clock reference sourced from the Media Access Controller (MAC), or an external clock source, to the Physical Layer (PHY). Doubling the clock frequency to 50 MHz allows a reduction of required data and control signals, thereby providing a low cost alternative to the IEEE Std 802.3u Media Independent Interface (MII). The RMII functions to make the differences between copper and optical PHYs transparent to the MAC sublayer.

The RMII specification has the following characteristics:

- It is capable of supporting 10 Mbps and 100 Mbps data rates
- A single clock reference is sourced from the MAC to PHY (or from an external source)
- It provides independent 2 bit wide (di-bit) transmit and receive data paths
- It uses TTL signal levels, compatible with common digital CMOS ASIC processes.

RMII Specification Signals

Signal Name	Direction (with respect of the PHY)	Direction (with respect to the MAC)
REF_CLK	Input or Output	Synchronous clock reference for receive, transmit and control interface
M[0:11]_CRS_DV	Input	Carrier Sense/Receive Data Valid
M[0:11]_RXD[1:0]	Input	Receive Data
M[0:11]_TX_EN	Output	Transmit Enable
M[0:11]_TXD[1:0]	Output	Transmit Data
M[0:11]_RX_ER	Input (Not required)	Receive Error

Table 5 - RMII Specification Signals

9.2 The Gigabit Media Independent Interface (GMII)

The GMII supports the 1000Mbps full-duplex operations of the MDS213, based on the Media Independent Interface (MII) defined by IEEE Std 802.3 (Clause 22). The GMII retains the names and functions of most of the MII signals, but defines valid signal combinations for 1000 Mbps operations. The GMII transfers data in each direction for the Data [7:0], Delimiter, Error, and Clock signals. The GMII implementation extends the Transmit Data (TXD) and Receive Data (RXD) signals of the MII from four bits wide to eight bits wide and synchronizes the data and the delimiters using a Gigabit Transmit Clock (GTX_CLK) instead of the MIIs' Transmit Clock (TX_CLK).

9.2.1 The MII Management Interface

The GMII uses the MII Management Interface is used to control and gather status information from the Gigabit Physical Layer (PHY) to configure MDS213 operations using Auto-negotiation. The management interface consists of a pair of signals, called the M_MDIO and M_MDC management pins.

9.2.2 MII Command and Status Registers

The MDS213 utilizes the MII Command and Status registers defined in the 10/100Mbps Specification and additional extended registers to support Auto-negotiation (IEEE Std 802.3, Clause 37). The commonality of the MII management registers will allow the MDS213 to determine the capabilities supported by the PHY and to implement such functions as "Start of Frame" and "Determine PHY Address."

9.3 The Physical Coding Sublayer with Ten Bit Interface (TBI):

Zarlink MDS213 includes the Physical Coding Sublayer (PCS) block. It performs 8B/10B conversion between GMII and Ten Bit Interface (TBI). The Collision Detect (COL) and Carry Sense (CRS) signals are generated from PCS to GMII internally when using TBI interface PHY. The PCS block also includes an Auto Negotiation function. The PCS block can be disabled by using the Device Configuration Register (DCR2) when GMII interface PHY is used.

10.0 The Control Bus

The CPU Interface, or Control Bus, provides the communication path between the system CPU and all other key components within the MDS213 (i.e. the HISC). It operates in two modes: managed mode, where it utilizes an external CPU, and unmanaged mode, where an external CPU does not exist.

In Managed mode, the CPU Interface provides the communication path between the systems' external CPU and the HISC, Frame Buffer Memory (SRAM) or another MDS213. See Figure 11.

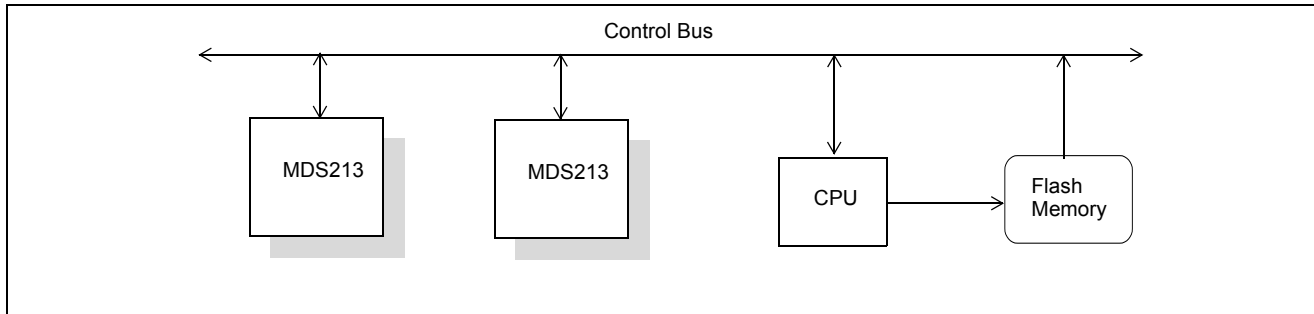

Figure 11 - CPU Interface Configuration in Managed Mode

In unmanaged mode, the CPU Interface provides the communication path between the Switch Devices and Flash Memory, and between any two MDS213 Switches. See Figure 12.

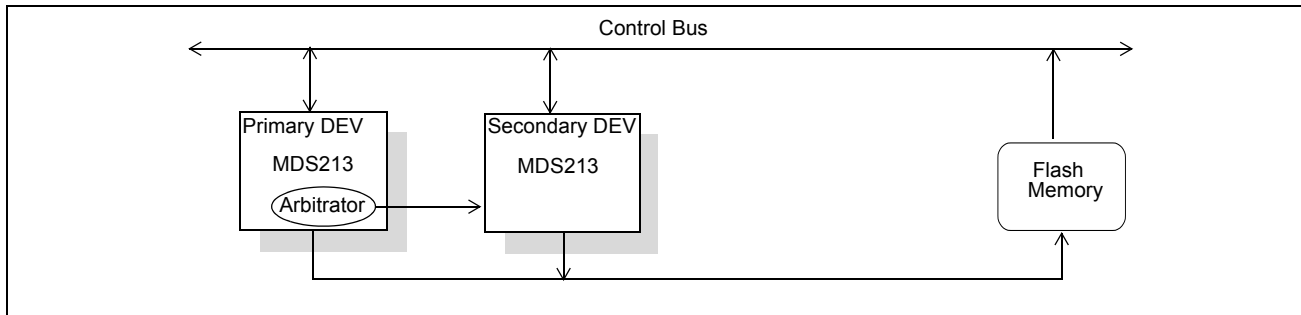

Figure 12 - Control Bus Configuration in Unmanaged Mode

10.1 External CPU Support

The control bus comprises of a 32-bit wide CPU bus and supports Big and Little Endian CPU byte ordering. The standard microprocessors supported include:

- Intel 486 CPUs
- Motorola MPC860 and 801 CPUs
- Intel i960Jx CPU
- MIPS processor with minimum conversion

10.1.1 Power On/Reset Configuration

On power-up, the following five Bootstrap bits, of Table 6, are used:

Name	Default	Functional Description
BS_BMOD	1	Bus Mode
		Must be 0
BS_RW	1	Selects R/W Control polarity 0=R/W# 1=W/R#
BS_SWM	1	Switch Mode (only in Managed Mode) 0=Managed Mode 1=Unmanaged Mode
BS_PSD	1	Primary Device Enable (only in Unmanaged Mode) 0=Secondary Mode 1=Primary Mode (The arbiter is activated in the chip with Primary Device.)
BS_RDYOP	1	Option of merger the P_RDY# and P_BRDY# 0=merged P_RDY# and P_BRDY# pin 1=Separated P_RDY# and P_BRDY# pins

Table 6 - Bootstrapping Options

10.1.2 CPU Bus Clock Interface

The CPU Interface allows the CPU bus clock to operate at clock rates different from the system clock rate. The CPU Bus Clock rate is always less than or equal to the System Clock rate.

10.1.3 Address And Data Buses

The CPU Interface provides separate, non-multiplexed address and data buses. The data bus is a synchronous, 32-bit bus that can receive 16 or 32-bit wide data. The Flash memory uses a 16-bit data bus. The data bus supports 32 bit wide data for managed and unmanaged modes. The address bus supports 10 [10:1] address bits for managed and unmanaged modes. Each device occupies 2048 bytes of Input/Output space.

10.1.4 Bus Master

The nomenclatures "Master" and "Slave" refer to the device that possesses the CPU Interface, or Control Bus, while the designations of "Primary" and "Secondary" refer to the device that possesses the Bus Arbiter. The primary or secondary device is determined during Power On/Reset, bootstrap options, while the master or slave device changes dynamically, and will be determined by the Arbiter.

In managed mode, the systems' external CPU is the permanent master device. All other devices (e.g., the MDS213) are designated as slave devices only. In unmanaged mode, the arbiter (located within the primary device) selects one of the devices as the Master.

Note: In unmanaged mode, the primary device may be the Master or the Slave. The master device is the bus master (controls the bus), while the other device is a slave device.

10.1.5 Input/Output Mapped Interface

The systems' external CPU accesses the switch devices' local memory using single-read/write or burst - read/write I/O cycles. Burst I/O operations with auto address incrementing uses a 32-byte write data buffer and a 32-byte cache read data buffer.

10.1.6 Interrupt Request

The CPU Interface accepts an Interrupt Request (IRQ) from each device connected to the interface, and supports centralized interrupt arbitration and vector response. The interrupt output is an open-drain option with programmable polarity.

10.2 Control Bus Cycle Waveforms

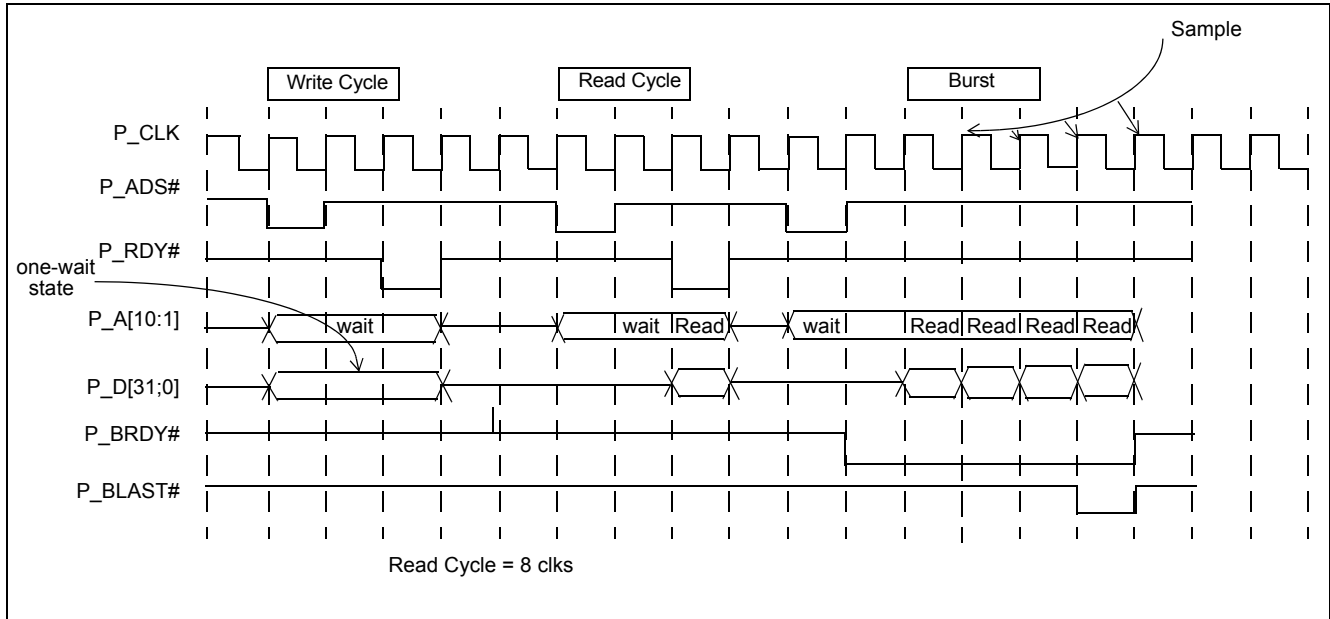

Figure 13 - Control Bus I/O

10.3 The CPU Interface in Unmanaged Mode

In unmanaged mode, the HISC processor of the Master device communicates with the slave device as a CPU function. Three registers and one flag are used to communicate between the HISC processor and the CPU Interface.

10.3.1 Arbiter

The arbiter of the XpressFlow MDS213 is an internal logic device used to determine which device will function as the master device. The connections between the master device, slave device, and the CPU are used for debugging purposes only. See Figure 14.

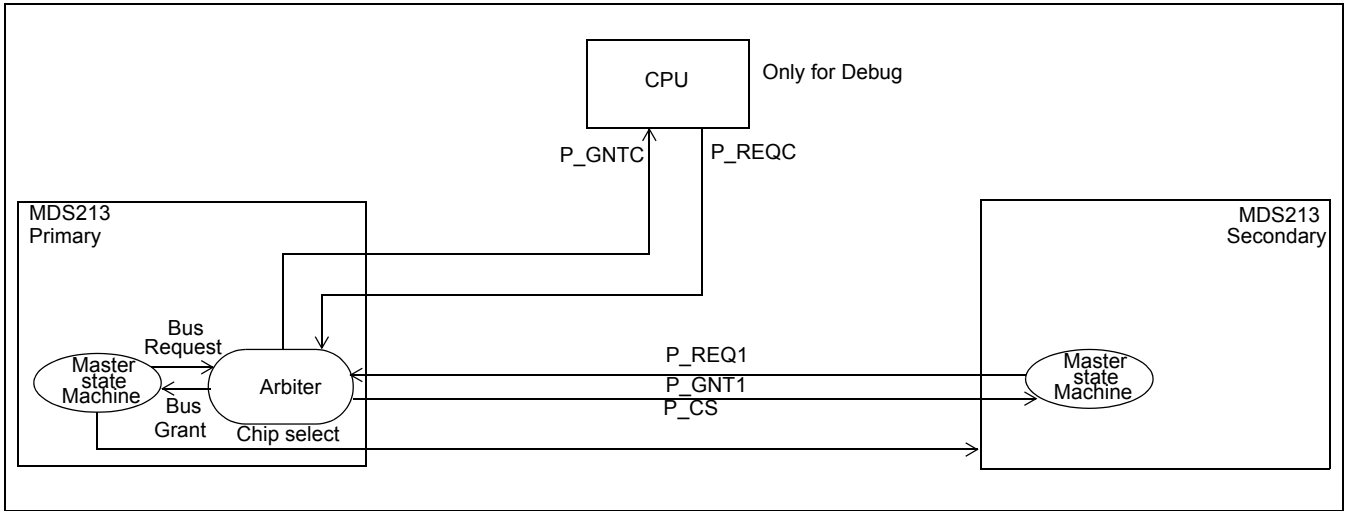

Figure 14 - Block Diagram of the Arbiter

Note: In unmanaged mode, the CPU is used only for debugging purposes and cannot be involved in switching decisions or management activities.

During Power On/Reset, the bootstrap pin, BS_PSD, determines which device will be the primary and activates the arbiter of that device. At most, three devices, two MDS213 devices and one CPU, can operate on the CPU Interface at the same time.

Each device may request access to the CPU Interface by sending a Request signal to the arbiter. The arbiter, then sends a Grant signal acknowledging which device has been chosen.

An arbitrate scheduler, located within the arbiter, decides which device functions as the Master device. If the Master is the secondary device, the arbiter will send a Grant signal and a Chip Select (P_CS) signal to the device. If the Master is the primary device, the Grant signal is sent directly to the Master State Machine (MSM) by an internal signal. The scheduler then performs a round robin configuration and allows each device to be the Master device.

Note: During Power On/Reset, the arbiter always selects the primary device to be master device.

10.4 CPU Interface in Managed Mode

The CPU Slave State Machine (SSM) accepts Address Strobe (P_ADS#), Chip Select (P_CS#), and Bus-Data Ready (P_RDY#) signals as ready state signals of a CPU cycle.

10.4.1 CPU Access

The 32-bit CPU bus interface supports both Big and Little Endian CPUs. The difference between Big and Little Endian is the byte swapping when CPU writes data to external memory. Table 15 summarizes the byte swapping operation and Figure 15 illustrates an example of bytes swapping.

If using Little Endian	Bit[1] must be '0' for register of MWARS, MRARS, MWARB, MRARB	No byte swapping for CPU data write in or read out to/from MWDR, MRDR registers.
If using Big Endian	Bit[1] must be '1' for register of MWARS, MRARS, MWARB, MRARB	Automatic Byte swapping for CPU data write in or read out to/from MWDR, MRDR registers.

Figure 15 - Little and Big Endian Byte Swapping Operation

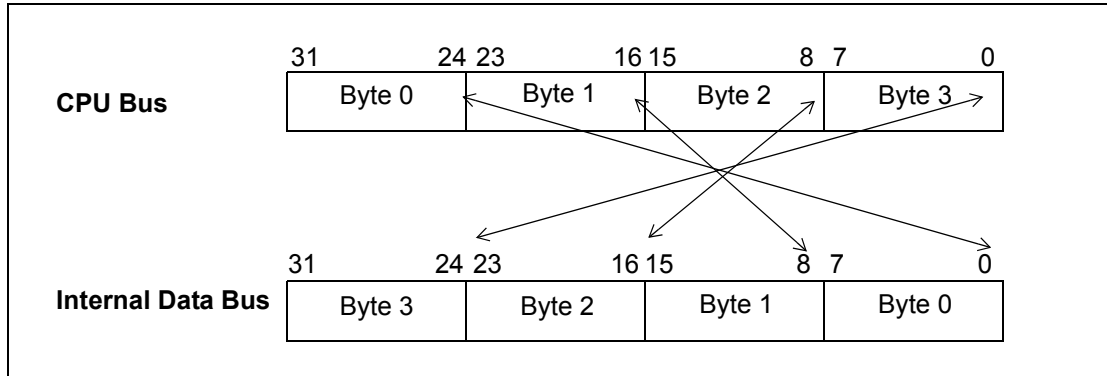

Figure 16 - An Example of Byte Swapping

11.0 The LED Interface

11.1 LED interface

The MDS213 LED interface supports the status per port in a serial stream that may be daisy-chained to connect two MDS213 chips. Daisy-chaining greatly reduces the pin count and number of board traces routed from the Physical Layer to the LEDs, thus simplifying system design and reducing overall system cost. For a large port configuration such as the 24+2 in the MDS213, a large number of LED signals is needed, which may induce noise and layout issues in the system. The LED information is transmitted in a frame-structured format with a synchronization pulse at the start of each frame.

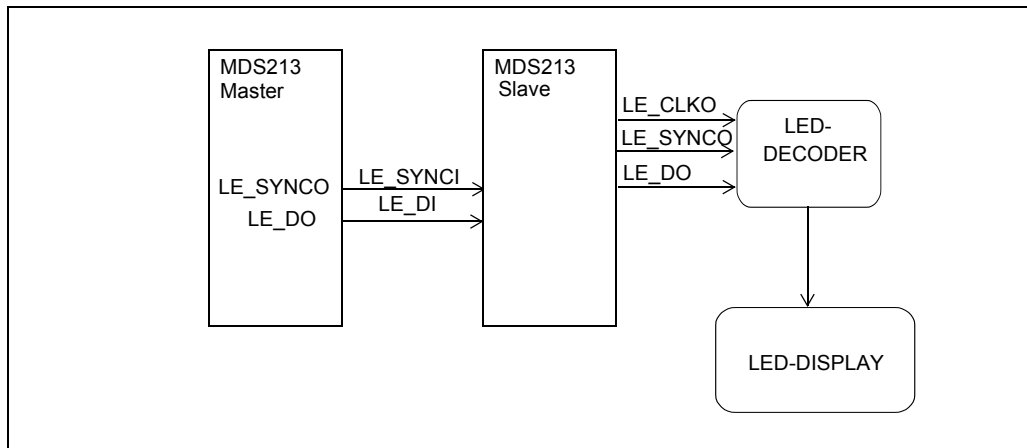

Figure 17 - LED Interface Connections

To provide the port status information from our MDS213 chips via a serial output channel, five additional pins are required.

- LE_CLKO - at 12.5 MHz
- LE_SYNCI/O - a sync pulse -- defines the boundary between frames
- LE_DI/O - a continuous serial stream of data for all status LEDs which repeats once every frame time

A low cost external device (i.e., a 44-pin FPGA-like device) decodes the LED framed data and drives the LED array for display. This device may be customized for different system configurations.

The port status of the MDS213 is transmitted to an external decoder via a serial output channel. In the MDS213, we support cascading of this serial output channel between two devices. One MDS213 is configured as the master, this initiates the start of LED information frames, and serializes information bits. The MDS213 slave repeats the information sent from the master and appends its own information bits. To cascade these two devices, we will need to extend the number of LED pins from 3 to 5. Figure 17 shows two cascaded LED interfaces and the connections between the MDS213s, the LED decoder, and the LED display.

11.1.1 Function Description

The LED interface employs the following signals:

Signal Name		Description
Master Device	Slave Device	
	LE_CLKO	LED Clock-Synchronous LED clock provided by the slave device to LED decoder at the system clock divided by 8 (~12.5 Mhz).
LE_SYNCI	LE_SYNCO	A synchronous pulse -- defines the boundary between frames. The length of each LED data frame is about 256 bits that shift out by LE_CLKO per bit.
LE_DI	LE_DO	A continuous serial stream of data for all status LEDs which repeat once every frame time.

Table 7 - LED Signal Names and Descriptions

11.1.2 Port Status

In the MDS213, each port consists of 8 different LED status, represented by separate bits:

1. Flow Control
2. Transmitting Data
3. Receiving Data
4. Action (TxD or RxD)
5. Link UP/DOWN
6. Speed
7. Full Duplex/Half Duplex
8. Collision

In addition to the 13 ports of the MDS213, three extra user-defined status sets may be sent through the LED serial channel for debugging or other applications, where each user-defined status set is also represented by 8 bits.

11.1.3 LED Interface Time Diagram

The Master needs to shift out $(13+3)*8$ status bits periodically. Thus, slave needs to shift out $(13+3)*8 + (13+3)*8$ status bits, which includes the status of the master device and itself.

The status of each port will be sampled by the LED State Machine every 20.5 μ s, the time period of the frame. That is, each LED data frame length equals $(256)X 80$ nsec. Each frame is divided into two subframes: a master and a slave sub-frame. Furthermore, each sub-frame is partitioned into 16 slots (13 MAC ports plus 3 user-defined sets) and each slot will carry 8 status bits. The following figure shows the signal from the slave chip to LED decoder.

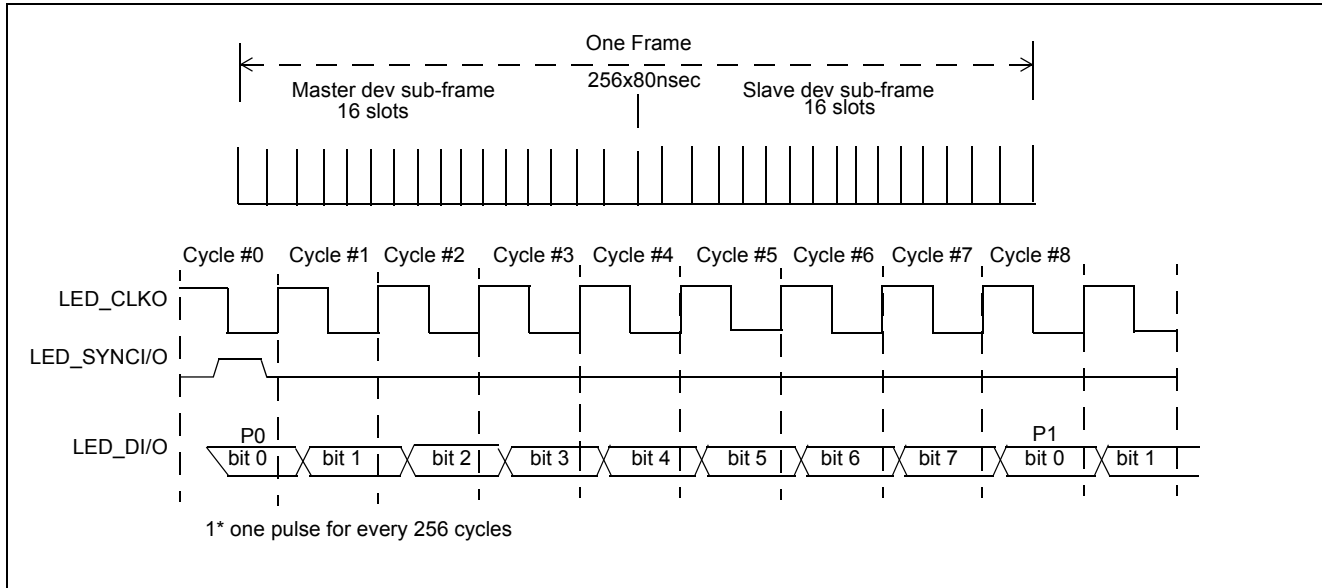

Figure 18 - Time Diagram of LED Interface

12.0 Data Forwarding Protocol and Data Flow

12.1 Data Forwarding Protocol

12.1.1 Frame Reception

For normal frame reception, a 128-byte block of frame data is stored in the RxFIFO. This block may be shorter if an End of Frame (EOF) arrives. At that point, the RxDMA will request the use of the internal memory bus. When this memory request is granted, the RxDMA will move the block from the RxFIFO to the Frame Data Buffer (FDB).

The MAC ports are partitioned into two groups, one for the Gbps Port and one for all 12 of the 100 Mbps Ports. The service discipline is round robin for both the Gbps Port and 100/10 Mbps group. After the entire frame is moved to the frame data buffer (FDB), a switch request will be sent to the Search Engine (Reference Search Engine Section)

12.1.2 Unicast Frame Forwarding

For forwarding of the unicast frame, the Search Engine first resolves the destination device and the destination port, and sends a switch response is sent back to the Frame Engine. The Frame Engine will obtain the type (unicast or multicast), the destination port, and the destination device from the search response. After processing the search response, the Frame Engine will notify the destination port that it has a frame to forward to the destination port's TxFIFO.

For local forwarding (e.g., the destination port is in the local device), the Frame Engine will send the job to the Transmission Scheduling queue of the destination port.

For remote forwarding (i.e., the destination port is in the remote device), the Frame Engine will create a data forwarding request command message (DATA_FWD_REQ), which is sent via the XPipe to the remote device. The remote Frame Engine, after receiving this DATA_FWD_REQ message, will place a job in the Transmission Scheduling queue of the destination port. The port will serve the next job from the Transmission Scheduling queue when the following two conditions are met:

- It is enough room for a 1.5Kbyte frame (a maximum-sized frame) within the TxFIFO.
- The end-of-frame (EOF) of the current frame has arrived at the TxFIFO.

There are four transmission-scheduling queues for each port, one for each of the four classes of priority. The port will send the jobs to the transmission scheduling queues according to a first in first out (FIFO) order.

To start data transmission, the port obtains a job from the transmission scheduling queue and notifies the Transmit DMA (TxDMA) to move the data from the FDB to the MAC Transmit FIFO (TxFIFO) in 128-byte granules (for local forwarding). Otherwise, the device sends a DATA_REQ command message via the XPipe to the source device to request remote forwarding. The data forwarding engine module in the Frame Engine of the source device will then forward the frame in 128-byte granules via the XPipe.

12.1.3 Multicast Frame Forwarding

After the reception of the switching response, a job is sent to the Transmission Scheduling queues of the destination ports for local switching. However, for remote switching, one copy of the frame will be forwarded to the remote device in 128-byte granules via the XPipe. This copy of the frame will be sent to the frame data buffer. The Frame Engine, after the successful reception of this frame, will put jobs in the Transmission Scheduling queues of the destination ports of its device.

When the TxFIFO is ready to receive the frame (same as the conditions stated in unicast frame forwarding section), the TxDMA will forward the frame from the FDB to the destination ports in granule form. The maximum size of a granule is 128 bytes.

12.2 Flow for Data Frame

The following subsections describe the flow of information during transfers of data frames, both unicast and multicast.

12.2.1 Unicast Data Frame to Local Device

In the simplest case, the data frame is destined for a port on the local device. The Frame Engine moves the received frame to the local FDB. The Search Engine forms a switch request with the frame header (includes source MAC and Destination MAC) and passes it to the Switch Engine to resolve the destination. The Switch Engine then provides a destination port address to the Frame Engine via a switch response message. Frame Engine transmits put a transmission job in transmission scheduling. After the port is ready to send the frame, then frame start to move the frame to TxFIFO. If the MAC address cannot be resolved by the Switch Engine, the HISC and/or the CPU are queried to resolve the address. For unknown destination MAC, the frame will flood the frame into the source VLAN domain.

12.2.2 Unicast Data Frame to Remote Device

In the case, the data frame is destined for a port on a remote device. First, the Frame Engine moves the received frame to the local FDB. A switch request with frame header (includes source MAC and Destination MAC) is passed to Switch Engine to resolve the destination. The Switch Engine then provides a destination port address to the Frame Engine. If the address resolution cannot be completed by the Switch Engine, the HISC and/or the CPU are queried.

Once the address is resolved, the two Frame Engines performs the following interactive handshaking procedures via the XPipe:

- Source Frame Engine sends a Data Forwarding Request message to Destination, where the destination Frame Engine puts a job in the associated transmission scheduling queue.
- When the destination port is ready to send the frame, the destination Frame Engine send a Data Request message to the source Frame Engine.
- After the source Frame Engine receives the Data Request Message, it start to move the frame in granule form, which is directly written in the destination TxFIFO.

Note that, at the remote device, the frame is written into the transmit FIFO of the remote destination port. The frame is not stored in the FDB of the remote device again, so that the latency can be reduce.

12.2.3 Multicast Data Frame

In this scenario, we assume that the multicast frame involve both local and remote ports. The received multicast frame is written to the local FDB by the Frame Engine. After resolving the destinations, the Switch Engine then provides local destination port addresses and remote port address to the Frame Engine. If the address resolution cannot be completed by the Switch Engine, the HISC and/or the CPU are queried.

Frame Engine pushes the jobs to the corresponding transmission queues (per job per local port). When a local port is ready for this multicast frame, the Frame Engine moves the frame to the corresponding TxFIFO. There is a counter to track of the number of copies to be sent. The number is provided by Search Engine and the Frame Engine keeps track of this counter. When a frame is sent, the counter is decreased by one. The FDB will be released when the counter becomes zero.

When the destination ports involve remote ports, the frame is transferred over the XPipe to the remote Frame Engine, which writes a single copy of it into the remote FDB. That is we use double store-and-forward for remote multicast. After receiving the whole frame, the remote Frame Engine utilizes the control information in the internal header, which indicates the associated destination ports in the remote device to push the jobs into the corresponding transmission queues. When a port is ready for this multicast frame, the Frame Engine moves the frame to the corresponding TxFIFO. Similarly, the Frame Engine also keeps track of the number of copy of frame to be sent and release the frame when the counter is reduced to be zero.

12.3 Flow for CPU Control Frame

In managed system, CPU may transmit or receive CPU control frames, e.g., Protocols, SNMP frames to/from a MAC port via a CPU unicast frame. On the other hand, a CPU may receive a multicast frame from a MAC port. Moreover, CPU can transmit a multicast frame to multiple ports. Use four scenarios to illustrate the forwarding flow.

12.3.1 CPU Transmitting Unicast CPU Frame

The CPU initiates Unicast control messages, by first writing the frame into the FDB, and then sending a message to the HISC. The HISC forwards a switch response to the Frame Engine, which transmits the frame to the destination MAC port. After receiving switch response, Frame Engine performs the same unicast forwarding as for unicast data frame. Refer previous subsection for unicast data frame mechanism.

12.3.2 CPU Transmitting Multicast CPU Frame

When the CPU sends a multicast control message to ports, the CPU first writes the frame to the local FDB. The CPU then sends a message to the HISC, which provides a switch response message to the local Frame Engine. After receiving switch response, Frame Engine performs the same multicast forwarding as for multicast data frame. Refer previous subsection for multicast data frame mechanism.

12.3.3 CPU Receiving Unicast Frame

The receiving CPU frame is moved to FDB and the Frame Engine forwards a switch request including the frame header to Search Engine. After Search Engine decodes the header and determines to forward it to HISC to process. HISC informs the CPU via a mail, which indicates the handle of FDB. CPU then obtains the frame through the MDS213. After read the frame from FDB, CPU will inform HISC to release the FDB. Finally, HISC passes the release command to Frame Engine to release the FDB accommodated CPU frame.

12.3.4 CPU Receiving Multicast frame

The MDS213 is capable of receiving a multicast packet for a combination of local ports, remote ports, and also the CPU. In this case, the received frame includes multicast destination ports on a remote device, and also the CPU. The Frame Engine moves the multicast frame to FDB and then form a switch request including the frame header to Search Engine. Since the frame involves CPU, the Search Engine passes the request to HISC for further process. HISC informs CPU via a mail, which indicates the handle of FDB. In parallel, the Search Engine sends back a switch response and ask Frame Engine to forward the frame to destinations ports. Frame Engine will perform the same multicast forwarding as mentioned above.

CPU read the frame from FDB via MDS213. After read the frame from FDB, CPU will inform HISC to release the FDB. Finally, HISC passes the release command to Frame Engine to release the FDB accommodated CPU frame.

Note that the Frame Engine won't release FDB until it receives the release signal from HISC and also the counter is reduced to zero. That means all the ports and CPU have read out the frame.

13.0 Port Mirroring

13.1 Features

The received or transmitted data of any 10/100 port in any MDS213 chip, connected by Port Mirror signal pins, PM_DO and PM_DI, can be chosen to be mirrored to the "Mirror Port." The mirror port can be the first port in a MDS213 with RMII or a dedicated mirror port with MII, driven by the pin, PM_DO[0:1]. Once the first RMII port of a chip is selected to be the mirror port, it cannot be used to serve as a data port. The configuration of port mirroring is shown in the following diagram, based on the current evaluation board design.

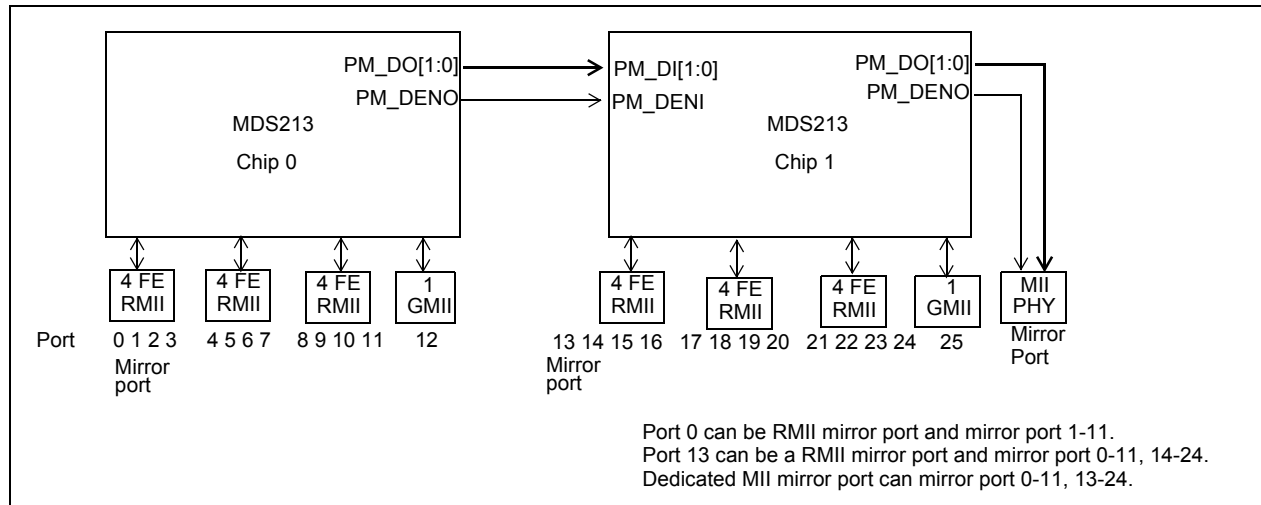

Figure 19 - Configuration of Mirror Port for MDS213

13.2 Physical Pins

There are 6 related pins to Port Mirroring functions:

- PM_DI [1:0] Port Mirroring Input Data Bit [1:0]
Receive the mirrored data signal from the remote MDS213.
- PM_DENI Port Mirroring Data Enable signal for PM_DI Input
Provide Data Enable signal for PM_DI signals
- PM_DO[1:0] Port Mirroring Output Data Bit [1:0]
Transmit the mirrored data signal to remote MDS213.
- PM_DENO Port Mirroring Data Enable Output.
Provide Data Enable signal for PM_DO signals

Refer to Figure 20 for connecting above pins.

13.2.1 Setting Register For Port Mirroring

The APMR register controls the mirrored port, the designated mirroring port. The definition of the register is shown as follows:

13.2.1.1 APMR- Port Mirroring Register

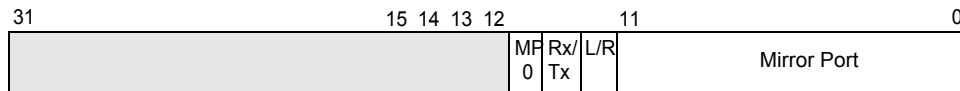

Bit [11:0]Mirr_Port10/100 port is chosen to be mirrored, (port bit map)

Bit [12] Local/RemoteIndicate the mirrored port from local or remote device.

0=local 1=remote

(**Note:** Not support 1G port Mirroring.)

Note that at most only one of bit in Bit[11:0] can be set to 1.

Bit [13] Rx/TxWhether mirror receiving data or transmitting data

0= Transmission Mirroring, 1=Receiving Mirroring

Bit [14] MP0Mirror to Port 0 (Default=0)

MP0=1 Mirror to port 0

MP0=0 Mirror not go to port 0. i.e., to PM_DO pins.

Bit [31:15]Reserve

We use examples to illustrate how to set the APMR register. The following examples are based on the configuration of Figure 20.

Example 1: Mirroring port 1 to port 0 and Mirror transmission direction.

For Chip 0

Set APMR[11:0]=0x002; mirrored port= 1

Set APMR[12]=0 ; local mirrored port

Set APMR[13]=0; Transmission mirroring

Set APMR[14]=1; Port 0 is the mirroring port

For Chip 1:

Don't Care

Example 2: Mirroring port 1 to port 13 and Mirror receiving direction.

For Chip 0

Set APMR[11:0]= 0x002; mirrored port= 1

Set APMR[12]=0 ; local mirrored port

Set APMR[13]=1; receiving mirroring

Set APMR[14]=0; Port 0 is not the mirroring port

For Chip 1:

Set APMR[11:0]=0x000

Set APMR[12]=1 ; remote mirrored port

Set APMR[13]=Don't careBit[13] has meaning only in the chip of mirrored port

Set APMR[14]=1; Port 13 is the mirroring port

Example 3: Mirroring port 1 to MII Mirroring port Mirror receiving direction.

For Chip 0

Set APMR[11:0]= 0x002; mirrored port= 1

Set APMR[12]=0 ; local mirrored port

Set APMR[13]=1; receiving mirroring

Set APMR[14]=0; Port 0 is not the mirroring port

For Chip 1:

Set APMR[11:0]= 0x000

Set APMR[12]=1 remote mirrored port

Set APMR[13]= Don't careBit[13] has meaning only in the chip of mirrored port

Set APMR[14]=0Port 13 is not the mirroring port

Note that CPU needs to find out the speed of the mirrored port and configures the mirroring port to the same speed.

14.0 Virtual Local Area Networks (VLAN)

14.1 Introduction

A Virtual LAN (VLAN) is a logical, independent workgroup within a network. The members in this workgroup communicate as if they are sharing the same physical LAN segment. VLANs are not limited by the hardware constraints that physically connect traditional LAN segments to a network. As a result, VLANs can define a network into multiple logical configurations.

14.2 VLAN Implementation

The MDS213 based VLAN implementation allows up to 256 VLANs in one switch. By using explicit or implicit VLAN tagging and the GARP/GVRP protocol (defined in IEEE 802.1p and 802.1Q), VLANs may span across multiple switches. A MAC address can belong to multiple VLANs, and a switch port may be associated with multiple VLANs.

14.2.1 Static Definitions of VLAN Membership

The MDS213 defines VLAN membership based on ports. Port based VLANs are organized by physical port numbers. For example, switch ports 1, 2, 4, and 6 can be one VLAN, while ports 3, 5, 7, and 8 can be another VLAN. Broadcasts from servers within each group would only go to the members of its own VLAN. This ensures that broadcast storms cannot cause a network meltdown due to traffic volume.

14.2.2 Dynamic Learning of VLAN Membership

While port based VLAN only defines static binding between a VLAN and its port members, the MDS213's forwarding decision needs to be based on the following:

- A destination MAC address and its associated port ID for a unicast frame, or
- The associated VLAN of a source MAC address, if the destination MAC address is unknown or it is a multicast/broadcast frame. To make valid forwarding and flooding decisions, the MDS213 learns the relationship of the MAC address to its associated port number and VLAN ID and builds up the internal Switching Database at run-time for further use.

14.2.3 Dynamic Learning of Remote VLAN

In addition to adding and deleting VLAN member ports through network management tools statically, a MDS213 based switch can also support GVRP (GARP VLAN Registration Protocol). GVRP allows for dynamic registration of VLAN port members within a switch and across multiple switches. In addition to supporting the dynamic update of registration entries in a switch, GVRP is also used to communicate VLAN registration information to other VLAN-aware switches, so that a VLAN member can be covered by a wide range of switches in a network. GVRP allows both VLAN-aware workstations and switches to issue and revoke VLAN memberships. VLAN-aware switches register and propagate VLAN membership to all ports belonging to the active topology of the VLAN.

14.2.4 MDS213 Data Structures For VLAN Implementation

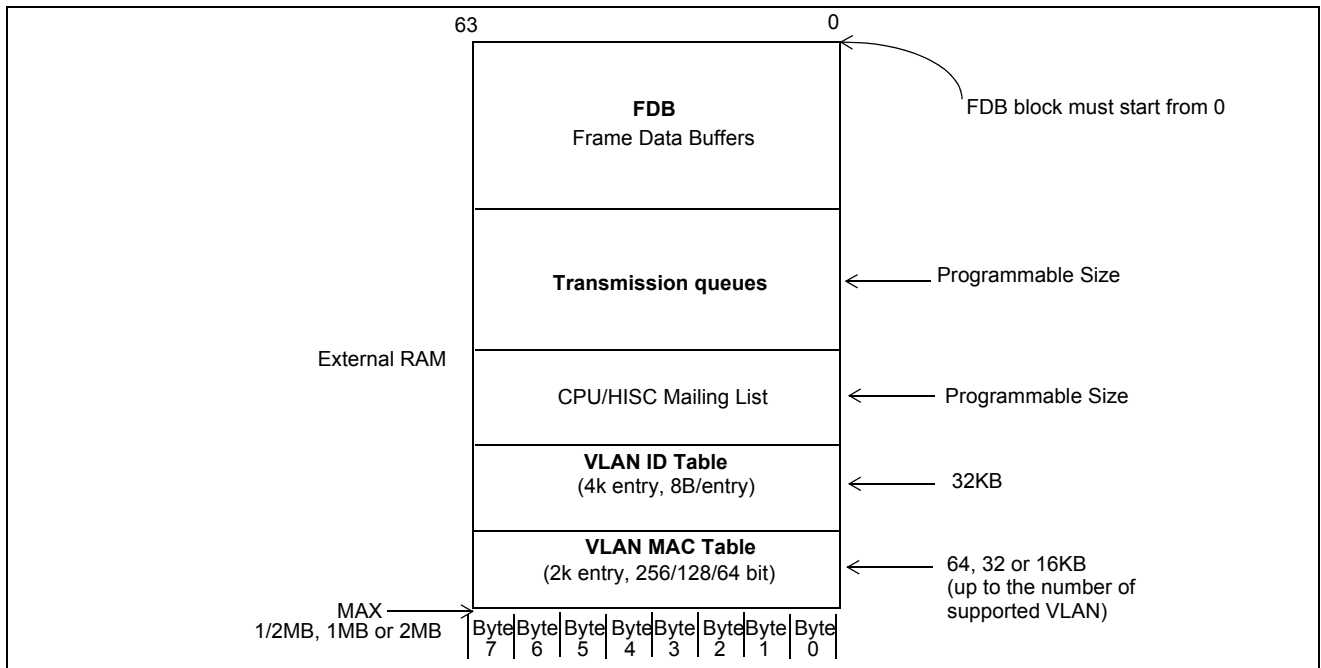

Figure 20 - Data Structure Diagram

14.2.4.1 VLAN ID Table

The VLAN ID Table is used by Search Engine for unicast frames. The base address of this table is specified by VIDB subfield in BIT[5:0] of VTBP register.

The contents of this table are set up by the MDS213's microcode through the command of CPU software at the time of VLAN creation and deletion. The VLAN ID Table covers the entire 4 K VLAN ID space, and is used by the Search Engine to map the VLAN ID into an internal VLAN Index. It also includes port membership and port tagging information for each VLAN. Each VLAN ID entry is 8 bytes long, and the total size of the VLAN ID Table is 32 KB. The VLAN ID table must be located at the 32 K boundary.

Byte	3	2	1	0	7	6	5	4	3	2	1	0	15	14	13	12	11	10	9	8	7	6	5	4	3	2	1	0
0	Index[3:0]	C	V	P	P12	P11	P10	P9	P8	P7	P6	P5	P4	P3	P2	P1	T	S										
4	Index[7:4]				P28											P17	P16											

Figure 21 - VLAN ID Table

Bit[1:0] P0VLAN Status for Port 0

Bit [0]S This port is a member of this VLAN

Bit [1]T Tagout

Bit[3:2] P1 VLAN status for Port 1

....

Bit [26]VLAN is Valid

Bit [27]CCPU is a member of this VLAN

Bit [31:28]1st byte: VLAN Index [3:0], 2nd byte: VLAN Index [7:4]

Note: P0 to P12 are used to identify the ports on the first chip, while P16 to P28 are used to identify the ports on the second chip.

14.2.4.2 VLAN MAC Table

The size of this table is defined by VLMS subfield in BIT[8:7] of VTBP register. The base address of this table is specified by VMACB subfield in BIT[15:9] of VTBP register. The VLAN MAC Table contains all associated VLANs for each MAC Address learned by MDS213, and is used by the software to keep track of every MAC and its associated VLANs. The contents of this table are set up by the Search Engine at the reception of incoming frames, if the Search Engine is not fully occupied. When the Search Engine is too busy handling frame forwarding decisions, microcode in the HISC engine will be assigned the setup new MAC to VLAN associations. Rows in this table can be cleared up by microcode through a CPU software command during VLAN deletion or port link down. A row in this table will be cleared and a new bit set up by the MDS213's microcode, when the port change of a MAC address is detected.

There is a total of 2 K entries in this table, one entry per MAC. Each entry may consist of 256, 128 or 64 bits, one bit per VLAN. The total size of the VLAN Table may be 64, 32 or 16 KB. This table must be located at the boundary of its own table size.

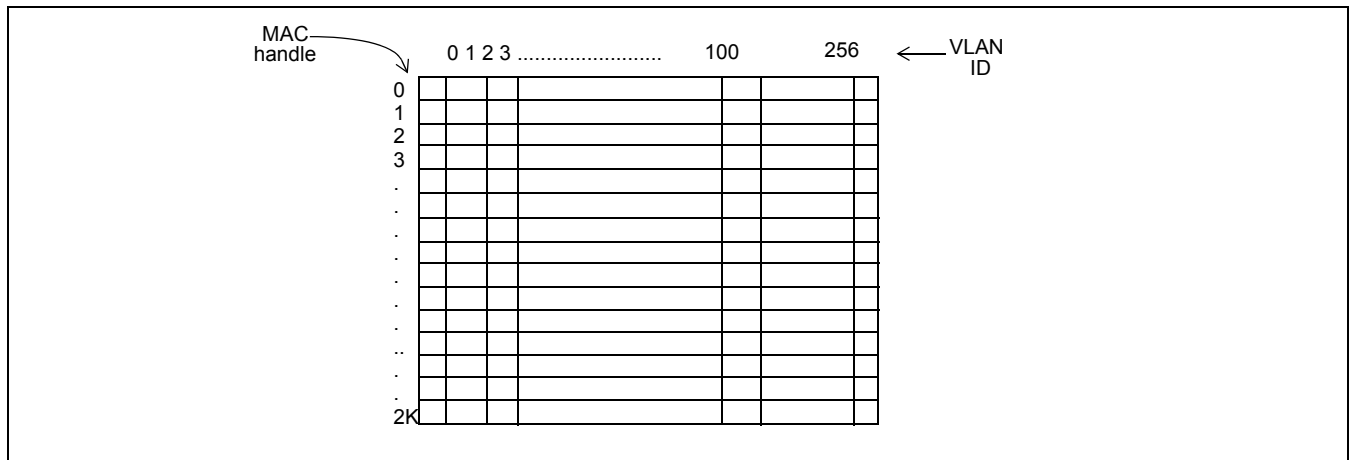
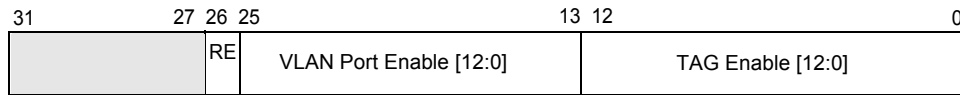

Figure 22 - VLAN MAC Table

This table can be accessed by CPU software through CPUIRCMD and CPUIRDAT registers.

14.2.4.3 VLAN Port Mapping Table (VMAP)

The VLAN Port Mapping Table (VMAP) is an internal table within the MDS213. It contains 256 entries, one for each VLAN, identified by an internal VLAN Index. The contents of this table are set up and maintained by CPU software during VLAN creation, deletion and VLAN port membership modification. VMAP is used by Frame Engine to forward multicast or destination unknown unicast frames to multiple ports simultaneously.



Bit [12:0]VLAN Tag Enable [12:0]One bit for each Ethernet MAC Port

0 = disable, 1 = enable

Bit [25:13]VLAN Port Enable [12:0]One bit for each Ethernet MAC Port, identifying the ports

associated with each VLAN. 0 = disable, 1 = enable

Bit [26]RE Remote Ports Enable: Indicate some members in the remote

device.0=disable, 1=enable

Bit [31:27]Reserve

14.2.4.4 Port VLAN ID (PVID) Register

This register defines the Port VLAN ID (PVID) and priority for each port. PVID needs to be set up by CPU software, and is used by MDS213 to decide the port's VLAN ID and priority if the incoming packet is VLAN untagged.

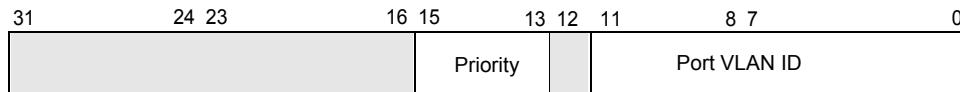

Bit [11:0]:Port VLAN ID (PVID),

Bit [12]:Reserved

Bit [15:13]: Priority

Bit [31:16]:Reserved

15.0 IP Multicast

15.1 Introduction

IP Multicast permits an IP host (source) to transmit a single IP packet to multiple IP hosts (receivers). IP Multicasting allows a source to send only one copy and the network ensures delivery to each member of the specified multicast group. Network bandwidth is allocated more efficiently, as multiple copies of the same frame are not transmitted between common ports.

The packet destined to an IP multicast group address determines the set of recipients. Hosts may choose to be members of a number of multicasts, and hence select the multicast packets they wish to receive. They may subscribe or unsubscribe to these multicast groups dynamically, using the Internet Group Management Protocol (IGMP) that support automatic multicast group membership. IGMP is configured to create, update, and/or remove

dynamic multicast group entries between switches and multicast clients and servers. RFC 1112 specifies the protocols and behaviour for IP Multicasting.

The MDS213 supports up to 255 IP Multicast Groups and treats them as extensions of the VLAN operation. No additional hardware is needed, since the IGMP operates on the hardware already provided for VLAN functionality. IGMP packets are identified by the Search Engine and are passed to the external CPU for processing, when the destination MAC address is 01-00-5E-xx-xx-xx, Protocol field value equals 2 and the destination IP address is 224.0.0.x. The external CPU then instructs the HISC to setup IP Multicast entries for the MAC Addresses in the Switch Database Memory, the VLAN Table, and the MCT-VLAN Table. The HISC builds and maintains an MCT-VLAN and a VLAN Table for IP Multicast Groups in the Frame Buffer Memory.

When an IP Multicast packet is received, it is identified by a specific class of Multicast Destination MAC addresses, where the high-order bits indicate use of IGMP, and the low-order bits indicate the specific IGMP Group Identifier. The MDS213 searches the MCT VLAN Association Table for destination MAC addresses, using the IGMP or the IGMP Group Identifier stored in the MCT, to obtain port membership for the IP Multicast Group. The Search Engine forwards the packet to each port associated with the IP Multicast Group. Where no address is found, the HISC firmware updates the MCT-VLAN to include this address.

The Multicast Buffer Control Register (MBCR) allows the configuration of multicast frames to be forwarded, the number of buffers reserved for receiving remote multicast frames, the number of multicast frames allowed, and the multicast forwarding threshold.

15.2 IGMP and IP Multicast Filtering

IP multicast filtering optimizes switched network performance by limiting multicast packets to only be forwarded to ports containing multicast group membership instead of flooding all ports in a subnet (VLAN).

The Internet Group Management Protocol (IGMP) runs between hosts and their immediate neighboring multicast routers. The mechanism of the protocol allows a host to inform its local router that it wishes to receive transmissions addressed to a specific multicast group. Routers, also, periodically query the LAN to determine if known group members are still active.

Based on the group membership information, learned from the IGMP, a router is able to determine which (if any) multicast traffic needs to be forwarded to each of its "leaf" sub-network. Multicast routers use this information, in conjunction with a multicast routing protocol, to support IP multicasting across the Internet.

The MDS213 based switch supports IP Multicast Filtering by passively snooping on the IGMP Query. The IGMP Report packets are transferred between IP Multicast Routers and IP Multicast host groups to learn the IP Multicast group members within each VLAN actively sending out IGMP Query messages soliciting IP Multicast group members. They thus learn the location of multicast routers and member hosts in multicast groups within each VLAN.

Since IGMP is not concerned with the delivery of IP multicast packets across sub-networks, an external IP multicast router will be needed if the IP multicast packets have to be routed across different IP sub-networks.

15.3 Implementation in MDS213

The MDS213 supports up to 255 IP Multicast Groups and treats them as an extension of the VLAN operation. No additional hardware is needed, since IP Multicast Switching/Filtering already operates in hardware provided for VLAN functionality.

IGMP packets are identified by the Search Engine and are passed to the external CPU for processing, when the destination MAC address is 01-00-5E-xx-xx-xx, Protocol field value equals 2 and the destination IP address is 224.0.0.x. The external CPU then instructs the HISC to setup an MCT entry for this IP Multicast Address in the Switch Database Memory. If this is a new IP Multicast group, it sets up an entry in the VLAN Port Mapping Table by itself.

Whenever an IP Multicast data packet (destination MAC = 01-00-5e-xx-xx-xx, and destination IP address is within the range of 224.0.1.0 and 239.255.255.255) is received, the Search Engine will use the MCT table to look up the IP Multicast address of the incoming packet. Frame Engine then will use the result from the search (VLAN Index) to forward this IP Multicast packet to its member ports according to the VLAN Port Mapping Table.

15.3.1 MCT Table

The MCT table is an internal table within the MDS213 chip that has a total of 2 K entries. The CPU setups and read the table one entry at a time through microcode in the HISC. There are two types of overlapped MCT entries, one used for layer-2 MAC address based unicast switching, and the other for IP Multicasting.

15.3.1.1 MCT Structure For Unicast Frame

The MCT table is used by the Search Engine to forward unicast frames. By looking up a destination MAC address from this table, the associated port number is found and used for packet forwarding decisions. The content of the table is set up by the Search Engine at the reception of an incoming frame, if the Search Engine is not fully occupied. When the Search Engine is too busy handling frame forwarding decisions, microcode in the HISC engine will be assigned to do the learning job by setting up new MAC to Port associations.

An entry in this table can be setup by microcode in HISC through a CPU software command for static layer-2 packet filtering based on either the source or destination address. An entry can be cleared by microcode in the HISC through a CPU software command, during VLAN deletion, port link down, or when it is aged out. It will also be cleared and a new one set up when a port change of a MAC address is detected.

Byte	3	3	2	2	2	2	2	2	2	2	2	1	1	1	1	1	1	1	1	1	9	8	7	6	5	4	3	2	1	0
0	MAC3					MAC2					MAC1					MAC0					T									
4	S		P		S		D		Port number					MAC5					MAC4											
8																Next Handle														
12																														

T: Time stamp, used for aging. Set to 1 after MAC is found, and cleared to 0 when aged.

MAC[5:0]:MAC Address

S: Source MAC address filtering

D: Destination MAC address filtering

SP: Transmit Speed. 1- Gbps, 0-100Mbps

Next Handle: Pointer to the next entry in a hashed link list.

15.3.2 MCT structure for IP Multicast Packet

An IP Multicast entry in the MCT table can be setup or torn down by microcode in HISC through a CPU software command for IP Multicasting. Whenever an IP multicast data packet is received, the Search Engine will use this table to look up the IP Multicast address and VLAN ID of the incoming packet. If the IP Multicast address is found, an internal VLAN Index from the MCT entry will be used by the Search Engine and Frame Engine to forward the IP Multicast packet to the specific IP Multicast group members in a VLAN. If not, the packet will be forwarded to the VLAN it belongs to.

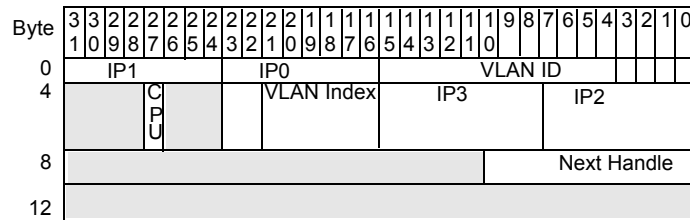

VLAN ID: The VLAN ID this IP Multicast group is located in.

IP[3:0]: IP Multicast Address

VLAN Index: Internal VLAN Index used to identify this IP Multicast group

CPU: 1: Switch CPU is part of this IP Multicast group

Next Handle: Pointer to the next entry in a hashed link list.

16.0 Quality of Service (QoS)

Quality of Service (QoS) provides the capability to reserve bandwidth throughout the network. This is particularly useful for sending voice or video over the switched network. In a switched Ethernet environment, this is only possible with Resource Reservation Protocol (RSVP), a Layer 3 protocol. In a Layer 2 switch, QoS, referred as Class of Service (CoS) by the IEEE 802.1Q standard, provides the capability to prioritize certain tasks on the network. This is done at the application level, where applications can set the priority when the frame is created. The MDS213 classifies Ethernet frames according to their IEEE 802.1p/Q VLAN priorities. There are three bits in the VLAN ID reserved to designate the priority of a packet.

Each port stores its transmission jobs into four transmission scheduling queues, one for each priority. Before transmitting, a port selects a queue from which a transmission job is read. The transmission job points to a frame stored in memory that is fetched and transmitted. The four queues, representing four classes of traffic, are selected using a weighted round robin (WRR) strategy. The relative service rates among these queues are programmable such that bandwidth can be allocated according to classes. This ensures that critical applications get a fair share of bandwidth, even when the network is overloaded.

The Search Engine recognizes the IEEE 802.1p priority tag and classifies each incoming frame into four internal priority classes: P0, P1, P2 and P3, in decreasing priority. Since the IEEE 802.1p/Q allows up to eight priorities, a programmable mapping allows the user to map the 802.1p priority to the internal priority tag via register AVTC.

16.1 Weighted Round Robin Transmission Strategy

Frames of four different priorities are transmitted according to a weighed round robin (WRR) strategy. The WRR is a modified form of the fair round-robin strategy, in which the server visits the queues in turn. In a fair round-robin strategy, the server treats all queues equally and visits them with identical frequency. In a WRR, the queues are weighted, i.e., one queue may be visited more frequently than another. These weighs are programmable via register AXSC, in which the service rate ratio between two adjacent classes of traffic is set.

In register AXSC, setting QSW0=2, QSW1=QSW2=1 gives the service ratio 8:2:1:1, which is a good start for most LAN switches. This ratio allocates 67% = 8/12 of bandwidth to P0, 16% = 2/12 of bandwidth to P1, and P2 and P3 each receives 8.3% = 1/12 of bandwidth, assuming all frames have identical frame length.

16.2 Buffer Management Functions

The MDS213 stores frame data in frame buffers. The number of frame buffers in a system is the maximum number of frames a device can store. When all frame buffers are used, incoming frames cannot enter the memory and are discarded. Without buffer management, a congested port causes a backlog of frames that eventually occupy all

frame buffers. The MDS213 features buffer management functions that prevent a single type of traffic from depleting all frame buffers. The buffer manager limits the number of frames each destination port can store, thereby preventing congested ports from occupying all the buffers and blocking incoming frames.

The buffer manager examines the destination port of every frame stored, and increments a counter associated with this destination port. These buffer counters keep track of the number of buffers occupied by frames destined to each port. If the counter reaches a threshold, incoming frames destined for the associated port will be dropped. This threshold is programmable via register BCT and BCHL. Register BCT allows the user to program two thresholds, one high and one low. The user specifies a threshold, high or low, for each port in register BCHL.

The buffer manager also prevents multicast frames from occupying all frame buffers. A programmable threshold, register MBCR, limits the number of multicast frames stored in memory. In another word, buffers are reserved for unicast frames. A multicast forwarding job points to a multicast frame in memory fetched and forwarded by the Frame Engine across the XPipe to the remote device. The Frame Engine can only forward a handful of multicast frames simultaneously across the XPipe. Excess multicast forwarding jobs are stored in an internal FIFO, called the MC-Forwarding-FIFO. If the MC-Forwarding-FIFO is full, incoming multicast frames can no longer be forwarded to the remote device.

The MDS213 has a programmable option to recognize IP multicast (IPMC) frames. By default, IPMC frames are treated equally with Layer 2 multicast frames. This option gives IPMC privilege, in terms of buffer allocation, over regular Layer 2 multicast frames. In a broadcast storm, Layer 2 multicast frames are discarded before IPMC frames. The system has the flexibility to recognize a programmable IPMC MAC address signature, set by registers IPMCAS0, IPMCAS1, IPMCMSK0 and IPCMMSK1. If a programmable option, DCR2, bit 26, is turned on, the system reserves space in the MC-Forwarding-FIFO for IPMC frames. This ensures that Layer 2 multicast frames do not block IPMC frames.

17.0 Port Trunking

Port trunking groups a set of 8 MDS213 10/100Mbps physical ports into one logical link; however, all ports in the trunk group must be within the same access device, and each port can only belong to one trunk group. All ports in the Trunk group must belong to the same VLAN and share the same MAC Address. Each system can support up to 4 groups. Gigabit ports cannot be trunked.

Load distribution for unicast and multicast traffic is done based on a hash key, a hash function of the Source Address and the Destination Address.

17.1 Unicast Packet Forwarding

A trunked port will need to have its ECR1 MAC Port Configuration Register set by CPU software to contain its associated Trunk Group ID. Later on, when a new source MAC Address is learned through that port, the Trunk Group ID will be recorded in the MCT entry by either the Search Engine or the microcode in the HISC. The Trunk Group ID will be used for forwarding decision when the destination MCT entry of a received packet is found by the Search Engine, if the status field indicates that the address found is on a Trunk Group.

The Trunk Group ID is used by the Search Engine, along with the "hash key" (3 bits result of a hash operation between source address and destination MAC address), to access a Trunk Port Mapping Table entry in the internal RAM. Each entry in this table contains the device and port IDs for the physical port used to transmit this packet. Software needs to set these entries, using TPMXR and TPMTD registers, to distribute the traffic load across the ports in the Trunk Group. If the source MAC Address of an incoming packet is on a Trunk Group (based on the MCT information), the receiving port's TGID will be compared against the Trunk Group ID in the source MCT to decide whether the source MAC address has moved to another Trunk Group or not.

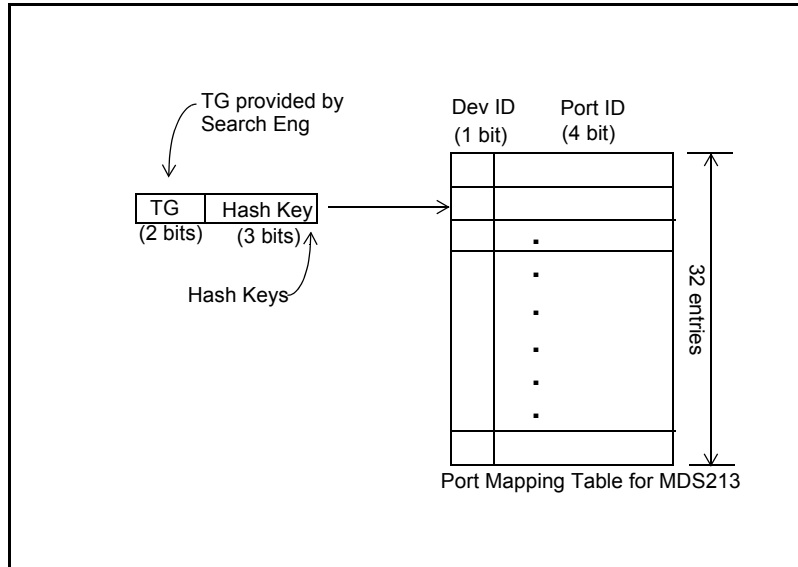

Figure 23 - Port Mapping Table

In Figure 23, the Trunk Port Mapping Table is 32 entries deep (4 groups * 8 hash entries), and each entry is 5 bits wide (1-bit device ID, 4-bit port ID), as show in the following format.

17.2 Multicast Packet Forwarding

For multicast packet forwarding, the destination device must determine the proper set of ports to transmit the packet based on the VLAN Index and Hash Key, generated by the source Search Engine. Two functions are needed to distribute multicast packets to the appropriate destination ports in a Trunk Group.

1. Selecting a Forwarding Port per Trunk Group:

Only one port per Trunk Group will be used to forward multicast packets. This can be done with a VLAN INDEX Table and a Forwarding Port MASK Table set up by CPU.

2. Blocking Multicast Packet Back to the Source Trunk:

For multicast forwarding that includes ports in Trunk Groups in the same device as source port, all ports in the same Trunk Group at the receiving port must be excluded. Otherwise, this multicast packet will be looped back to the same source Trunk Group. This is achieved through a Trunk Group ID Register that contains 36 bits (36=12x3).

17.2.1 Select One Forwarding Port per Trunk Group

To forward multicast frames, the Frame Engine retrieves the VLAN member ports from one of the 256 entries in the VLAN Port Mapping Table (VMAP) as described in the VLAN section. By using the Hash Key and the Forwarding Port Mask table, the Frame Engine can obtain the corresponding FP Mask. The final forwarding ports can then be determined by the logical AND of the FP Mask and the VLAN Member Port bit map. The Forwarding Port- Mask Table must be set by the CPU to THKM[0:7] registers beforehand. The format of this table and the method of setting it up are shown below.

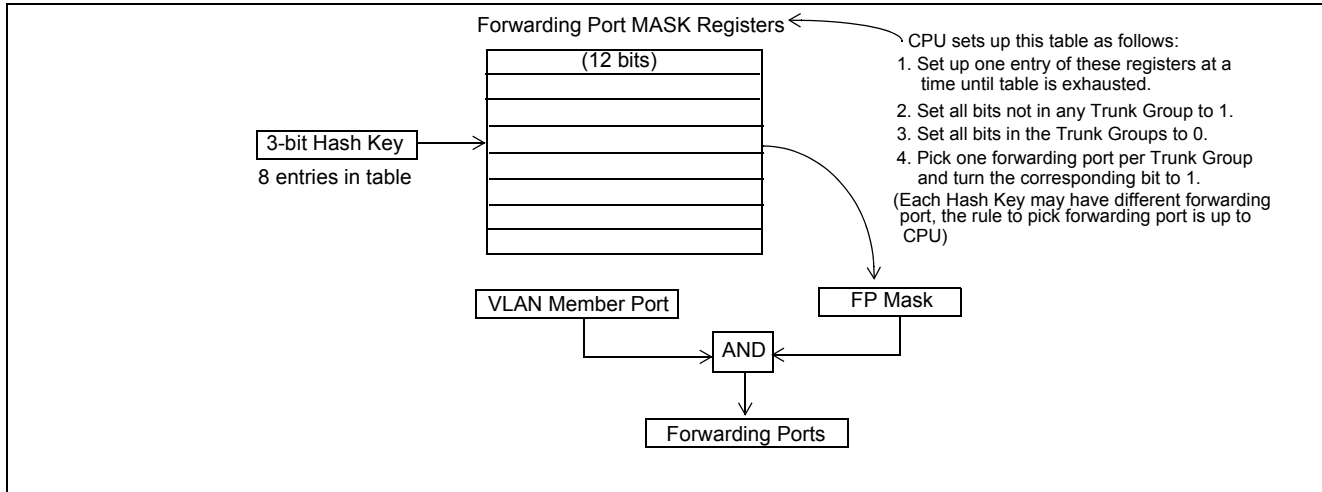

Figure 24 - Forwarding Port Mask Table

Two restrictions exist in setting up tables:

1. When setting up the VLAN Port Mapping Table, all the ports in the Trunk Group must be set to 1, if the VLAN has ports in any Trunk Group.
2. When setting up the Forwarding Port Mask Table, the CPU software picks only one forwarding port per Trunk Group.

17.2.2 Blocking Multicast Packets Back to the Source Trunk

For local multicast packets, the Frame Engine needs to block the multicast packets from being sent to the same Trunk Group as the receiving (source) port. To do it, the Search Engine utilizes the Trunk Group ID (TGID) in ECR1 Register.

The Frame Engine compares the TGID of the source and forwarding ports. If the two TGIDs are the same, the Frame Engine blocks the forwarding port for this multicast packet. The Switch Engine provides the TGID of the source port.

Example

The following is an example demonstrating this port trunking scheme for multicast packet forwarding:

4 Trunk Group in a switch:

- Group 0: port 0,1,2 in device 0
- Group 1: port 4, 5,6 in device 0
- Group 2: port 1, 2,3 in device 1
- Group 3: port 4, 5,6 in device 1

A multicast packet with VLAN INDEX=5 is received at port 0 of device 0.

The membership of this VLAN:

- Device 0: port 0,1,2, 4,5, 6, 7
- Device 1: port 1,2, 3, 4,5,6, 8

Hash Key = 3

Forwarding Port for each group with Hash Key=3,

Port 2 for Group 0

Port 4 for Group 1

Port 3 for Group 2

Port 6 for Group 3

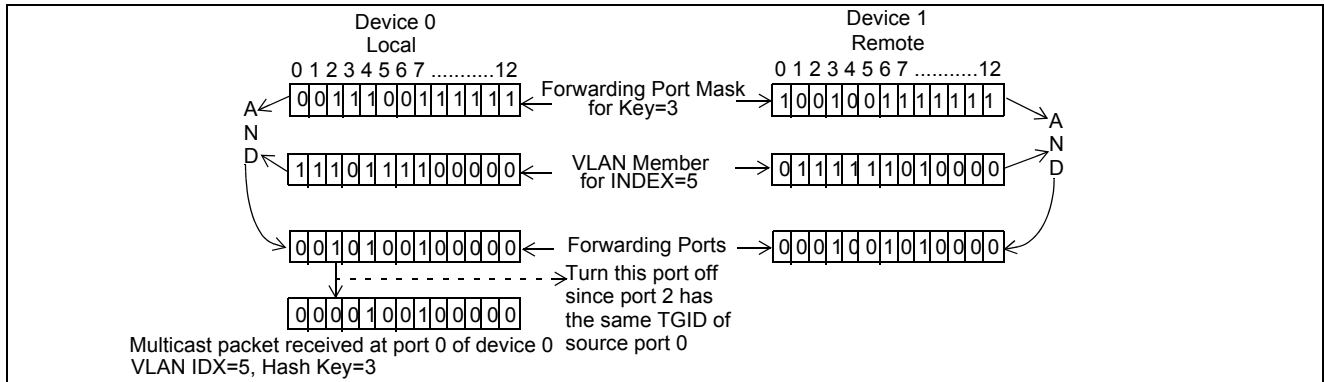

Figure 25 - Multicast Packet Forwarding Example

17.3 MAC Address Assignment

In MDS213, there are three ways to assign the MAC address to each port. All the ports in the same device share the 44 MSBs, MAC[47:4], which are shown in ADAR0 and ADAR1 registers, while the 4 LSBs, MAC[3:0] are specified in ADAOR0 and ADAOR1 registers for port 0-port 7 and port 8-port 12, respectively.

The method to assign the 4 LSBs MAC[3:0] can be assigned as follows:

- If the switch does not support Port Trunking, MAC[3:0]= port number
- If the switch supports multiple MAC addresses and Port Trunking, the ports in the same Trunk Group share the same MAC[3:0]. The value of MAC[3:0] is assigned by the Trunk Group (TG) Table.
- If the switch supports only a single MAC address, all the 4 LSBs of MAC will be set the same value in ADAOR0 and ADAOR1 register.

18.0 Register Definitions

18.1 Register MAP

All registers are grouped into sets:

- Device Configuration
- Buffer Memory Interface
- Frame Control Buffer
- Queue Management
- Switching Control
- Link List Management
- Access Control Functions
- MAC Port Control

Access Control:

W/R = These register bits may be read from and written to by software

W/-- = These register bits may be written to by software, but not read. Write Only

(--/R) = These register bits may be read but not written to by software. Read Only

Latched and held bits

Clear bits

Permanently set bits

All registers are 32-bit wide. They are classified in the following tables:

Tag	Description	Address	W/R
1. Device Configuration Registers (DCR)			
GCR	Global Control Register	7C0	W/--
DCR0	Device Status Register	7C0	--/R
DCR1	Signature & Revision & ID Register	7C4	W/R
DCR2	Device Configuration Register	7C8	W/R
DCR3	Interface Status Register	7CC	--/R
MEMP	Memory Packed Register	7DC	W/R
2. Interrupt Controls			
ISR	Interrupt Status Register - Unmasked	7E0	--/R
ISRM	Interrupt Status Register - Masked	7E4	--/R
IMSK	Interrupt Mask Register	7E8	W/R
IAR	Interrupt Acknowledgement Register	7EC	W/--
3. Buffer Memory Interface			
MWARS	Memory Write Addr. Reg. - Single Cycle	780	W/--
MRARS	Memory Read Addr. Reg. - Single Cycle	784	W/--
MWARB	Memory Burst Write Address Register	788	W/--
MRARB	Memory Burst Read Address Register	78C	W/--
MWDR	Memory Write Data Register	790	W/--
MRDR	Memory Read Data Registers	794	--/R
VTBP	VLAN ID & MAC member Table Base Pointer	798	W/R
MBCR	Multicast Buffer Control Register	79C	W/R
RAMA	RAM block access Register	7A0	W/R
Reserve	Must Set to "0x0001 0008"	7B8	W/R
Reserve	Must Set to "0x0001 0000"	7BC	W/R

Table 8 - MDS213 Register Map

Tag	Description	Address	W/R
4. Frame Control Buffers Management			
FCBSL	FCB Stack Size Limit	740	W/R
FCBST	Frame Ctrl Buffer Stack - Buffer Low Threshold	744	W/R
BCT	Buffer Counter Threshold	74C	W/R
BCHL	Buffer Counter Hi-Low Selection	750	W/R
5. Queue Management			
CINQ	CPU Input Queue	708	W/--
COTQ	CPU Output Queue	70C	-/R
6. Switching Control			
HPCR	HISC Processor Control Register	6C0	W/R
HMCL0	HISC Micro-Code Loading Port-Low	6C4	W/R
HMCL1	HISC Micro-Code Loading Port-High	6C8	W/R
HPRC	HISC Priority Control Register	6D0	W/R
MCS0R	Micro Sequence 0 Register	6D4	W/R
MCS1R	Micro Sequence 1 Register	6D8	W/R
FCR	Flooding Control Register	6DC	W/R
MCAT	MCT Aging Timer	6E0	W/R
TPMXR	Trunk Port Mapping Table Index Register	6E4	W/--
TPMTD	Trunk Port Mapping Table Data Register	6E8	W/R
PTR	Pacing Time Regulation	6EC	W/R
MTCR	MCT Threshold & Counter Register	6F0	W/R
7. Link List Management			
LKS	Link List Status Register	680	W/R
AMBX	Mail Box Access Port	684	W/R
AFML	Free Mail Box List Access Port	688	W/R
8. Access Control Function Group 1 (Chip Level controls)			
AVTC	VLAN Type Code	648	W/R
AXSC	Transmission Scheduling Control Register	64C	W/R
ATTL	Transmission Timing & Threshold Control Register	650	W/R
AMIIC	MII Command Register	654	W/--
AMIIS	MII Status Register	658	--/R
AFCRIA	Flow Control Ram Input Address	65C	W/--
AFCRID0	Flow Control Ram Input Data	660	W/R
AFCRID1	Flow Control Ram Input Data	664	W/R

Table 8 - MDS213 Register Map (continued)

Tag	Description	Address	W/R
AFCR	Flow Control Register	670	W/R
AMAR0	Multicast Addr. For MAC Control Frames Byte [3,2,1,0]	674	W/R
AMAR1	Multicast Addr. For MAC Control Frames Byte [5,4]	678	W/R
AMCT	MAC Control Frame Type Code Register	67C	W/R
ADAR0	Base MAC Address Register - Byte [3,2,1,0]	600	W/R
ADAR1	Base MAC Address Register - Byte [5,4]	604	W/R
ADAOR0	MAC Offset Address Register Port [7:0]	608	W/R
ADAOR1	MAC Offset Address Register Port [12:8]	60C	W/R
ACKTM	Timer for SOF Check	610	W/R
AFCOFT10	Flow Control Off Time for 10Mbps port	614	W/R
AFCOFT100	Flow Control Off Time for 100Mbps port	618	W/R
AFCOFT1000	Flow Control Off Time for Giga port	61C	W/R
AFCHT10	Flow Control Holding Time for 10 port	620	W/R
AFCHT100	Flow Control Holding Time for 100 port	624	W/R
AFCHT1000	Flow Control Holding Time for Giga port	628	W/R
9. Access Control Function Group 2 (Chip Level controls)			
APMR	Port Mirroring Register	5C0	W/R
PFR	Protocol filtering Register	5C4	W/R
THKM0	Trunking Forward Port Mask 0 (hash key=0)	5C8	W/R
THKM1	Trunking Forward Port Mask 1 (hash key=1)	5CC	W/R
THKM2	Trunking Forward Port Mask 2 (hash key=2)	5D0	W/R
THKM3	Trunking Forward Port Mask 3 (hash key=3)	5D4	W/R
THKM4	Trunking Forward Port Mask 4 (hash key=4)	5D8	W/R
THKM5	Trunking Forward Port Mask 5 (hash key=5)	5DC	W/R
THKM6	Trunking Forward Port Mask 6 (hash key=6)	5E0	W/R
THKM7	Trunking Forward Port Mask 7 (hash key=7)	5E4	W/R
IPMCAS0	IP multicast MAC address signature Low Register - Byte [3:0]	5E8	W/R
IPMCAS1	IP multicast MAC address signature High Register - Byte [5:4]	5EC	W/R
IPMCMSK0	IP multicast MAC address Mask Low Register - Byte[3:0]	5F0	W/R
IPMCMSK1	IP multicast MAC address Mask High Register - Byte[5:4]	5F4	W/R
CFCBHD	FCB Handle Register for CPU	580	--/R
CPUIRCMD	CPU Internal RAM Command Register	584	W/R
CPUIRDAT0	CPU Internal RAM Data Register - 0	588	W/R

Table 8 - MDS213 Register Map (continued)

Tag	Description	Address	W/R
CPUIRDAT1	CPU Internal RAM Data Register - 1	58C	W/R
CPUIRDAT2	CPU Internal RAM Data Register - 2	590	W/R
CPUIRRDY	Internal RAM Read Ready for CPU	594	--/R
LEDR	LED Register	598	W/R
10. Ethernet MAC Port Control Registers - (substitute [N] with Port Number, N = {0..12})			
ECR0	MAC Port Control Register	[N*4]0	W/R
ECR1	MAC Port Configuration Register	[N*4]4	W/R
ECR2	MAC Port Interrupt Mask Register	[N*4]8	W/R
ECR3	MAC Port Interrupt Status Register	[N*4]C	--/R
ECR4	Status Counter Wrap Signal	[N*4+1]0	--/R
PVIDR	PVID Register	[N*4+2]4	W/R

Table 8 - MDS213 Register Map (continued)

18.2 Register definitions

18.2.1 Device Configuration Register

18.2.1.1 GCR - Global Control Register

Access: Zero-Wait-State, Direct Access, Write only

Address: h7C0

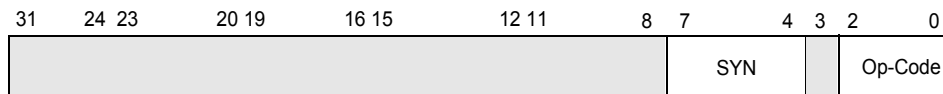

Bit [2:0] Op-Code 3-bit Operation Control Code

Op-Code	Command	Description
000	Clr RST	Clear Device Reset: - Allows state machines to exit from RESET state and to initialize their internal control parameters if necessary.
001	RESET	Device Reset: -- Resets all internal state machines of each device and stays in RESET state (except the Processor Bus Interface logic).
010	EXEC	Execution: -- Allows state machines to start their normal operations.
011	--	No-Op
1XX	--	No-Op

Table 9 - Global Control Register

Bit [7:4] SYN bits, reserved for HISC Usage.

18.2.1.2 DCR0 - Device Status Register

Access: Zero-Wait-State, Direct Access, Read only

Address: h7C0



Bit [1:0] Status 2-bit Operation Control Code

* Power-up default = 00

Status	State	Description
00	INIT	Initialization: Device is in idle state pending for system software initialization.
01	RESET	Device Reset: Device is in RESET state.
10	EXEC	Execution: Device is under normal operation.

Table 10 - Device Status Register

Bit [31:2] Reserved

18.2.1.3 DCR1 - Signature, Revision & ID Register

Access: Non-Zero-Wait-State, Direct Access, Write/Read

Address: h7C4

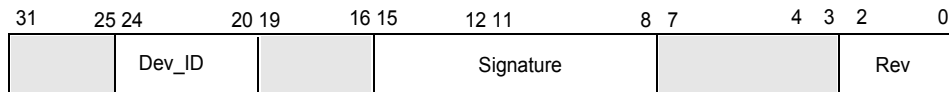

Bit [3:0] Device Revision Code

Bit [7:4] Reserved

Bit [15:8] Signature 8-bit Device Signature

Bit [19:16] Reserved

Bit [24:20] DEV_ID 5-bit Device ID (**Read/Write**)

Bit [31:25] Reserved

18.2.1.4 DCR2 - Device Configuration Register

Access: Non-Zero-Wait-State, Direct Access, Write/Read

Address: h7C8

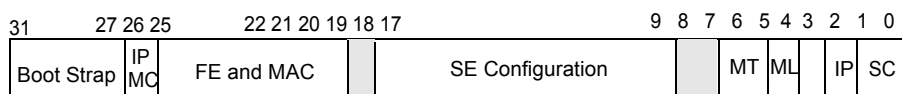

Bit [1:0]	SC	System Clock Rate 00= 100Mhz 10=90Mhz	Default = 00 01 = 120Mhz 11= 80Mhz
Bit [2]	IP	IRQ output polarity control 0 = active low output	Power-up default =0 1 = active high output
Bit [3]	SM	System Configuration mode 0=Nonblocking (For MDS213, always equal to 0) 1=Blocking	

SRAM Memory Characteristics

Bit [4]	ML	Buffer Memory Level, which can be either 2 chips or 4 chips. 0 = 2 memory chips 1 = 4 memory chips	Default = 0
Bit [6:5]	MT	Memory Chip Type 00 = 64K x 32-bit 10 = 256K x 32-bit	Default = 01 01 = 128K x 32-bit 11 = 512K x 32-bit
Bit [8:7]		Reserved	

Search Engine Configuration

Bit [9]	SE_AGEN	Aging enable, if which is true, the old MCT can be aged out. 0 = disable aging	Default = 1 1 = enable aging
Bit [11:10]	HM	Hashing Mode, each of which uses different bits of MAC address to come up with each bit of hashing key. 00=mode 0 0=mode 2	Default = 00 01=mode 1 11=mode 3
Bit [13:12]	HS	Hashing Size 00= 8 10= 10	Default = 01 01= 9 11= TDB
Bit [14]	VSW	VLAN Aware Switch 0 = VLAN Unaware	Default = 0 1 = VLAN Aware
Bit [15]	NoIPM	No IP Multicast 1 = IP Multicast Disable	Default = 1 0 =IP Multicast Enable
Bit [16]	GLN	Global Learning Disable, where CPU shall disable global learning before look into it as a whole piece. 1 = Learning Disable	Default = 0 0 = Learning Enable
Bit [17]	Partial Syn enable	Partial Synchronization enable for MAC Table 0= Fully Synchronization for MCT table	Default=0 1= Partial Synchronization for MCT table

Bit [18] Reserved

Frame Engine and MAC Configuration

Bit [19]	FE_AGEN	Aging enable. If true, the memory resources, occupied by the old message, will free up. 0 = disable aging	Default = 1 1 = enable aging
Bit [20]	FOF	Forward Oversize Frames 0 = Discard oversize frames	Power-up default =0 1 = Forward oversize frames
Bit [21]	Dec_Buffer_CNT	Decrements buffer counter. When the software writes "1" to this bit, the Frame Engine decreases buffer counter by one.	
Bit [22]	BC_EN	Buffer counter enable 0 = Disable (no head of line control)	1 = enable
Bit [23]	STA_EN	Status counter enable 0 = collect status in counter disable	1 = collect status in counter enable
Bit [24]	SEL_PCS	0 = Use external PCS	Default=0 1 = Use internal PCS in the chip
Bit [25]	Link_GT	TX LED will be off when the link is down and this bit is 0 0 = Gate Off TX_En when Link down	Default =0 1 = Not Gate off TX_En when Link down
Bit [26]	IPMC	IP Multicast privileges enable: IP multicast traffic has a privilege over regular multicast traffic. 0= disable	Default=0 1= enable

Boot Strap Determine by the bootstrap value.

Bit [27]	BMOD	Control Bus Mode (Read only bit) Must BE 0	
Bit [28]	RW	CPU Read/Write Control Polarity Selection 0 = R/W#	Read only bit 1 = W/R#
Bit [29]	SWM	Switching Mode (Read only bit) 0 = Managed mode	Default=1 1 = Unmanaged mode
Bit [30]	PSD	Master Device Enable (Read only bit) 1 =Primary	Default=1 0 = Secondary
Bit [31]	MRDY	Option of merge the RDY and B_RDY as one pin 0 =merged pin	Default=1 1 = separated pins

18.2.1.5 DCR3 - Interfaces Status Register

Access: Zero-Wait-State, Direct Access, Read only

Address: h7CC



Bit [3:0]	Reserved	
Bit [7:4]	Mem_Stat	Buffer Memory Interface Status
Bit [4]	BB	Buffer Memory Busy, CPU interface is busy accessing Memory
Bit [5]	RE	Read FIFO Empty, the FIFO that CPU interface reads is empty
Bit [6]	WE	Write FIFO Empty, the FIFO that CPU writes is empty
Bit [7]	Res.	Reserved
Bit [11:8]	Que_Stat	Queue Manager Interface Status
Bit [8]	IQ_Rdy	CPU Input Queue is ready for CPU to write into queue
Bit [9]	IQ_Full	CPU Input Queue is full
Bit [11:10]	Reserved	
Bit [31:12]	Reserved	

18.2.1.6 MEMP - Memory Packed Register

Access: Non-Zero-Wait-State, Direct Access, Write/Read

Address: h7DC

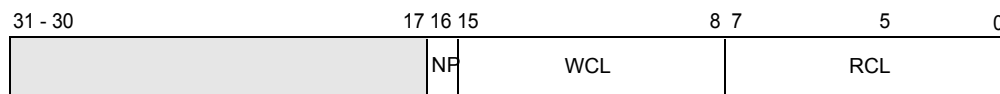

Bit [7:0]	RCL	Read Cycle Limit (Unit is system Clock). Threshold of reads cycle time.	Default=16
Bit [15:8]	WCL	Write Cycle Limit (Unit is system Clock). Threshold of writes cycle time.	Default=16
Bit [16]	NP	Not Packed NP=0 Enable the feature of memory read/write packed.	Default=0 NP=1 Disable, memory access will be a pure round-robin scheme.
Bit [31:17]	Reserved		

18.2.2 Interrupt Control Registers

Four 32-bit Control Registers.

ISR Interrupt Status Register Identify the unmasked interrupt request sources

Access: Zero-Wait-State, Direct Access, Read only

Address: h7E0

ISRM Masked Interrupt Status Reg. Identify the sources of interrupt with masking

- Access: Zero-Wait-State, Direct Access, Read only
- Address: h7E4

IMSK Interrupt Mask Register Defines the interrupt sources to be masked

- Access: Non-Zero-Wait-State, Direct Access, Write/Read
- Set bits to 1 to mask the corresponding interrupt sources
- Address: h7E8

IAR Interrupt Acknowledgment Reg. Clear the interrupt request bits

- s Access: Non-Zero-Wait-State, Direct Access, Write only
- s Set bits to 1 to clear the corresponding interrupt sources
- s Address: h7EC

All 4 registers have a common register format and bit assignment

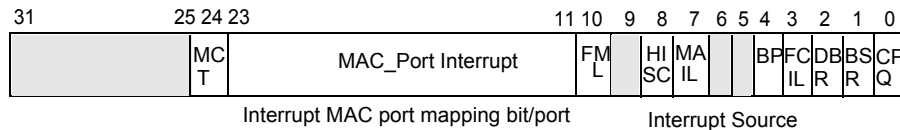

Interrupt Sources (The following bits need to be redefined.)

Bit [0]	CPU_Q_Out	CPU output queue level interrupt
Bit [1]	BSR	Bad switch response
Bit [2]	Double R	Double Release
Bit [3]	FCB_Low	FCB Low
Bit [4]	HISC_BP	HISC instruction pointer matched with Breakpoint Register
Bit [5]	Reserved	
Bit [6]	Reserved	
Bit [7]	MAIL_ARR	Mail arrived from HISC
Bit [8]	HISC_TO	HISC Timeout Interrupt
Bit [9]	Reserved	
Bit [10]	FML_Av	Link manager informs CPU that at least 16 Free Mail entry available after CPU encounters empty Free Mail list situation.
Bit [23:11]	MAC_PORT	Interrupt from MAC ports Bit [11] for Port 0, Bit [12] for Port 1 ... Bit [23] for port 12, port 12 is a Giga port

Bit [24] MCT Search Engine found looped MCT Chain.

Bit [31:25] Reserved

Note: MAIL_ARR, CPU_Q_Out and interrupts cannot be cleared by the CPU. They will be cleared whenever their queues are emptied.

18.2.3 Buffer Memory interface register

18.2.3.1 MWARS - Memory Write Address Register - Single Cycle

Access: Zero-Wait-State, via FIFO, Write

Address: h780

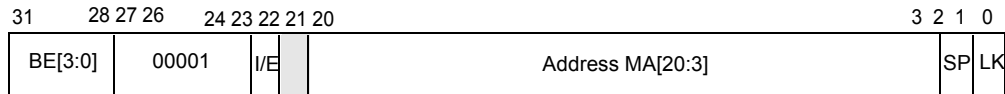

Bit [0] LK Lock Flag (for internal memory only) LK=0 Unlock LK=1 Lock

Bit [1] SP Swap Byte Order

Bit [20:2] MA [20:2] Buffer memory address Bit [20:2] - (Bit [1:0] = 00)

Bit [21] Reserved

Bit [22] I/E Indicates the Address is Internal or External memory
 I/E=0 Internal memory I/E=1 External memory

Bit [27:23] Count Must be 00001

Bit [31:28] BE [3:0] Byte lane enables

CPU Bus Type	Bit [31]	Bit [30]	Bit [29]	Bit [28]
Little Endian	BE [3]	BE [2]	BE [1]	BE [0]
Big Endian	BE [0]	BE [1]	BE [2]	BE [3]

18.2.3.2 MRARS - Memory Read Address Register - Single Cycle

Access: Zero-Wait-State, via FIFO, Write

Address: h784

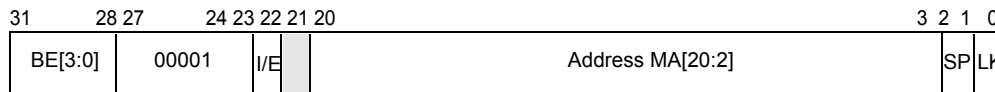

Bit [0] LK Lock Flag memory
 LK=0 Unlock LK=1 Lock

Bit [1] SP Swap Byte Order

Bit [20:2] MA [20:2] Buffer memory address Bit [20:2] - (Bit [1:0] = 00)

Bit [21] Reserved

Bit [22] I/E Indicate the Address is Internal or External memory
 I/E=0 Internal memory I/E=1 External memory

18.2.3.4 Memory Read/Write Data Registers

Four 32-bit data registers share a common format

- **MWDR** Memory Write Data Register
 - Access: Zero-Wait-State, via FIFO, Write only
 - Address: h790
- **MRDR** Memory Read Data Register
 - Access: Zero-Wait-State, Direct Access, Read only
 - Address: h794

Byte Order depends on CPU types

- Little Endian CPUs

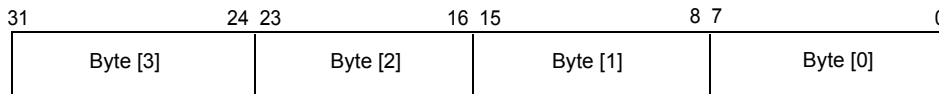

- Big Endian CPUs

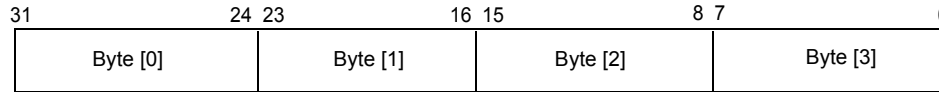

18.2.3.5 VTBP - VLAN ID Table Base Pointer

Access: Non-Zero-Wait-State, Direct Access, Write/Read

Address:h798

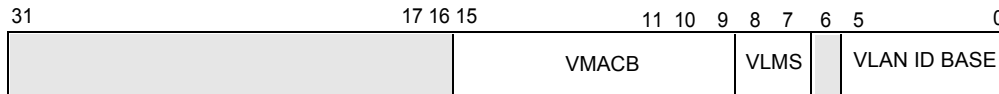

- Bit [5:0] VIDB VLAN ID Table Base, serves as [20:15] bits of address.
(VLAN ID Table is 32KB)
- Bit [6] Reserved
- Bit [8:7] VLMS The size of VLAN MAC Table Default=11
00= reserved 01=16K (for 64 VLANs)
10=32K (for 128 VLANs) 11=64K (for 256 VLANs)
- Bit [15:9] VMACB VLAN MAC Table Base, serves as [20:14] bit of address.
This table indicates the association of MAC address and VLAN
- Bit [31:16] Reserved

18.2.3.6 MBCR - Multicast Buffer Control Register

Access: Non-Zero-Wait-State, Direct Access, Write/Read

Address: h79C

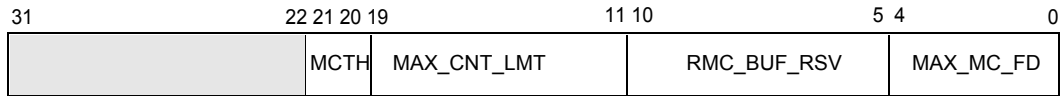

- Bit [4:0] MAX_MC_FD Maximum Number of Multicast Frames allowed for forwarding
- Bit [10:5] RMC_BUF_RSV Number of buffers reserved for receiving remote Multicast Frames
- Bit [19:11] MAX_CNT_LMT Maximum Number of Multicast Frames allowed per device
- Bit [21:20] MCFTH Multicast Forwarding Threshold: Watermark for forwarding FF to drop regular multicast packet if IPMC bit in DCR2[26] is ON. CPU can set four level watermarks, which are programmable
- | | |
|---------|----------|
| 00= 25% | 01=50% |
| 10= 75% | 11= 100% |

Bit [31:22] Reserved

18.2.3.7 AMA - RAM Counter Block Access Register

Access: Non-Zero-Wait-State, Direct Access, Write/Read

Address: h7A0

RAM counter block contains 13 counter blocks (one for each port) Port 0 counter block starts at address 0.) The size of each block is 16 double words, which consist of total 30 statistic counters. has total The size and type of each counter is referred to the register ECR4.

CPU uses this register to access the specified statistic counter by setting the start address of RAM counter block and the length.

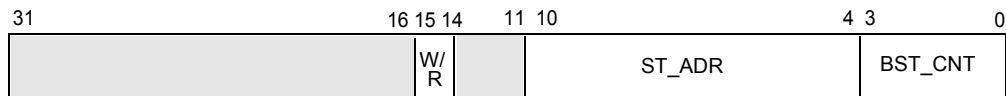

- Bit [3:0] BST_CNT Read/write burst (length) of RAM Block. (Unit = 1double words)
- Bit [10:4] ST_ADR Read/Write Start Address.
- Bit [14:11] Reserved
- Bit [15] W/R RAM Block Access Write/Read indicator
- | | |
|-----------|----------|
| 1 = Write | 0 = Read |
|-----------|----------|

Bit [31:16] Reserved

Note: The access range is equal to from ST_ADR to END_ADR= S_ADR+ BST_CNT. The END_ADR cannot cross the boundary of each port block, i.e., 8 double words.

18.2.3.8 Reserve Register 1

Access Non-Zero-Wait-State Direct-Access Write/Read

Address: h7B8

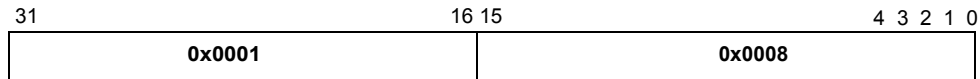
**Must be set to "0X00010008"****18.2.3.9 Reserve Register 2**

Access Non-Zero-Wait-State Direct-Access Write/Read

Address: h7BC

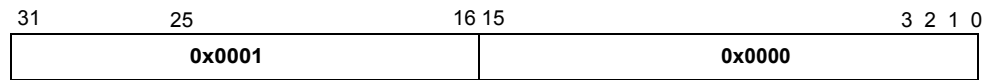
**Must be set to "0X00010000"****18.2.4 Frame Control Buffers Management Register****18.2.4.1 FCBSL - FCB Queue**

Access: Non-Zero-Wait-State, Direct Access, Write/Read

Address: h740

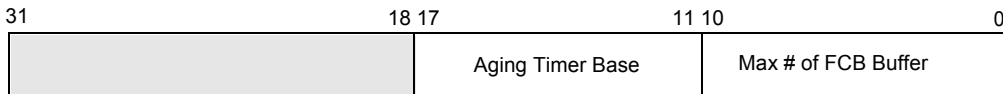

Bit [10:0] Defines Max # of FCB Buffers
Size Range: 1 entry, to 1024 entries

Bit [17:11] Aging Timer Base Defines the time interval between scanning of FCB Buffers for aged buffers
Aging Time = (Number of valid FCB Buffers* Aging Timer Base) msec

18.2.4.2 FCBST - FCB QUEUE - Buffer Low Threshold

Access: Non-Zero-Wait-State, Direct Access, Write/Read

Address: h744



Bit [5:0] Buf_Low_Th Buffer Low Threshold - The number of frame control buffer handles left in the Queue to be considered as running low and trigger the interrupt to the CPU.

Bit [31:6] Reserved

18.2.4.3 BCT - (FCB) Buffer Counter Threshold

Access Non-Zero-Wait-State Direct-Access Write/Read

Address: h74C

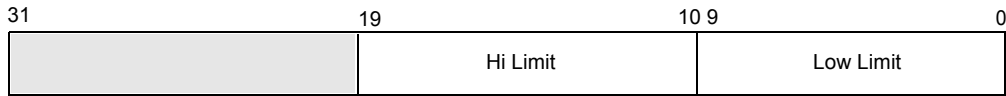

Bit[9:0] Low_Limit Low limit number of frames to each destination port (i.e., Source port limits the # of FCB used by each destination port)

Bit[19:10] HI_Limit High limit number of frames to each destination port (i.e., Source port limits the # of FCB used by each destination port)

18.2.4.4 BCHL - Buffer Counter Hi-low Selection

Access Non-Zero-Wait-State Direct-Access Write/Read

Address: h750

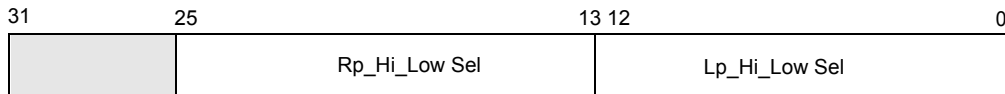

Bit[12:0] Lp_Hi_Low Sel Selection for Low or High Limit of Buffer Counter for Local device
13 bits maps to 13 ports in Local Device
1 = select hi limit 0 = select low limit

Bit[25:13] Rp_Hi_Low Sel Selection for Low or High Limit of Buffer Counter for Remote device
13 bits maps to 13 ports in Remote Device
1 = select hi limit 0 = select low limit

18.2.5 Queue Management Register**18.2.5.1 CINQ - CPU Input Queue**

Access: Non-Zero-Wait-State, Direct Access, Write only

Address: h708

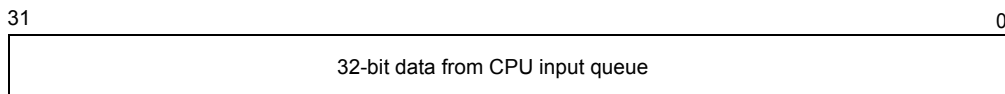

Note: Check IQ_RDY=1 in DCR3 (Interface Status Register) before writing into CPU Input Queue

18.2.5.2 COTQ - CPU Output Queue

Access: Non-Zero-Wait-State, Direct Access, Read only

Address: h70C

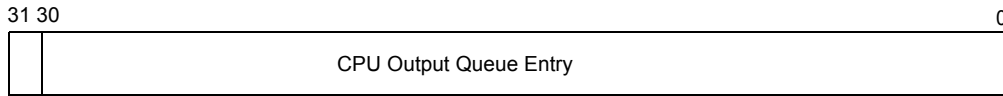

Bit [30:0] 31-bit CPU Output Queue Entry

Bit [31] Status queue is ready

18.2.6 Switching Control register

18.2.6.1 HPCR - HISC Processor Control Register

Access: Non-Zero-Wait-State, Direct Access, Write/Read

Address: h6C0



Bit [0] HT Halt the HISC processor from execution Not Apply for non-managed mode (It can be fixed in next cut.)Power-up default = 1

Bit [1] LD Switch the Micro-Code Memory from instruction fetch mode to downloading mode

Bit [2] RS Reset IP to 0 - (**Write only bit**)
(This bit is auto reset to 0 after IP is reset to 0)

Bit [31:3] Reserved

RS	LD	HT	State	Description
1	0	1	INIT	Initialization State: -- Stopped HISC execution, reset IP to 0.
0	0	1	HALT	Halt State: -- Stopped HISC execution, waiting for HT=0.
0	1	X	LOAD	Micro-Code Loading State: -- Stopped HISC execution, increment IP for every Wr/Rd to HMPC
1	0	0	START	Start State: -- Reset IP=0, and start HISC execution.
0	0	0	EXEC	Execution State: -- Continue HISC execution without reset IP.
1	1	X	--	Illegal State.

18.2.6.2 HMCL0 - HISC Micro-code Loading Port - Low

Access: Non-Zero-Wait-State, Direct Access, Write/Read
 Address: h6C4

Loading micro code into HISC.

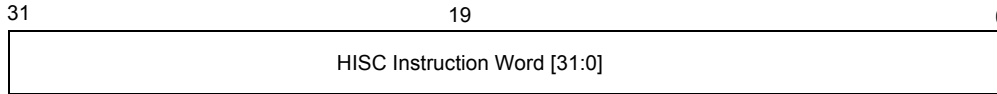

Bit [31:0] HISC Instruction Word [31:0] HISC Instruction Word has total 40 bit-wide. Needs to be broken into two registers.

18.2.6.3 HMCL1 - HISC Micro-code Loading Port - High

Access: Non-Zero-Wait-State, Direct Access, Write/Read
 Address: h6C8



Bit [7:0] HISC Instruction Word [39:32]
 Bit [31:8] Reserved

18.2.6.4 MS0R Micro Sequence 0 Register

Access: Zero-Wait-State, Direct Access, Write/Read
 Address: h6D4

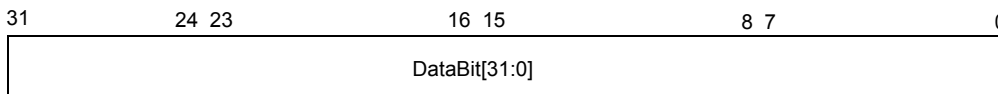

Bit [31:0] Data Bit [31:0] to the sequencer RAM
 (The length of Micro Sequence Data is 54-bit, Need to be broken into tow registers)

18.2.6.5 MS0R Micro Sequence 1 Register

Access: Zero-Wait-State, Direct Access, Write/Read
 Address: h6D8

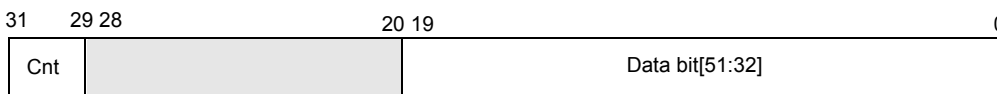

Bit [19:0] Data Bit [51:32] to the sequencer RAM
 Bit [31:29] CNT Control bits (Write only bits)
 000 NOP

001 Load
 010 Restart Ptr
 011 IncAdr
 100 Halt
 101 UnLoad
 110 UnHalt

Bit [28:20] Reserved

18.2.6.6 Flooding Control Register

Access: Non-Zero-Wait-State, Direct Access, Write/Read

Address: h6DC

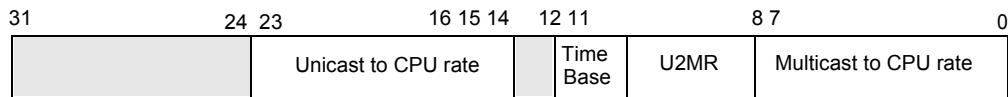

Bit [7:0] M2CR Multicast to CPU Rate
 Restricts the number of frames within the Time window defined in bit[15:12]

Bit [11:8] U2MR Unicast to Multicast Rate
 Restricts the number of flooding unicast frames within the Time window

Bit [14:12] Time Base Defines the time window used by M2CR and U2MR
 000 = 100us 001 = 200us 010 = 400us 011 = 800us
 100 = 1.6ms 101 = 3.2ms 110 = 6.4ms 111 = 100us

Bit [15] Reserved

Bit [23:16] U2CR Unicast to CPU Rate
 Restricts the number of frames within the Time window defined in bit[15:12]

Bit [31:24] Reserved

18.2.6.7 MCAT - MCT Aging Timer

Access: Non-Zero-Wait-State, Direct Access, Write/Read

Address: h6E0

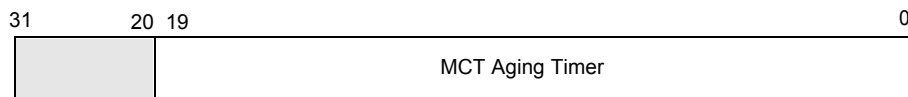

Bit [19:0] When the value is reached, it ages out
 Default=0 msec (unit=msec) Must be configured to not zero value.
 Suggestion value: 5msec.

18.2.6.8 Tpmxr – Trunk Port Mapping Table Index Register

Access: Non-Zero-Wait-State, Direct Access, Write/Read

Address: h6E4

For Trunk port mapping Table pointer

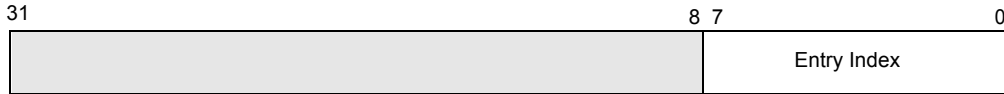

Bit [7:0] 8-bit Table entry Index

Bit [31:8] Reserved Value set to 0

18.2.6.9 TPMTD - Trunking Port Mapping Table Data Register

Access: Non-Zero-Wait-State, Direct Access, Write/Read

Address: h6E8

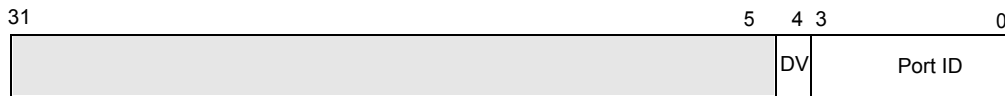

Bit [3:0] Port ID Trunking port

Bit [4] DV Device ID

Bit [31:5] Reserved

18.2.6.10 PTR - Pacing Time Regulation

Access Non-Zero-Wait-State Direct-Access Write/Read

Address: h6EC

Use for Pacing traffic to Remote Ports via XpressFlow Pipe or Local transmission

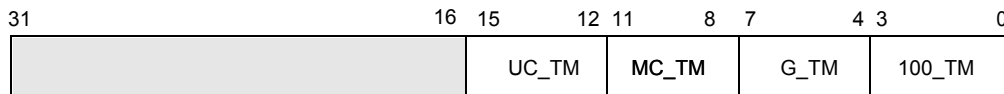

Bit [3:0] 100_TM 100M port timer Default =5

Bit [7:4] g_TM Gigabit port timer Default =6

Bit [11:8] mc_TM Multicast timer Default =5

bit[15:12] uc_TM Unicast timer Default =5

Unit time = 80 nsec.(for 64 Bytes Frame.)

Note that Frame Engine determine the tic value dependent upon the frame. If short frame, it takes above value. For long frame (> 64 frame), it will double the above value as the reference.

Bit [31:16] Reserved

18.2.6.11 MTCR - MCT Threshold & Counter Register

Access: Non-Zero-Wait-State, Direct Access, Write/Read

Address: h6F0

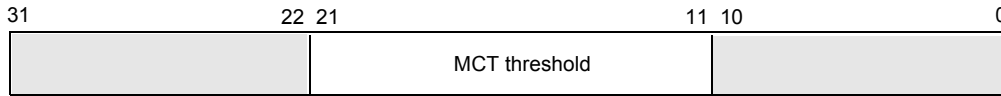

Bit [10:0] Reserved

Bit [21:11] MCT Threshold Alert system when free MCT entries are below this threshold

Bit [31:22] Reserved

18.2.7 Link List Management

18.2.7.1 LKS - Link List Status Register

Access: Zero-Wait-State, Direct Access, Read only

Address: h680



Bit [0] Mail Box is not ready for CPU to send entry to HISC
1=Not Ready0=Ready

Bit [1] Free Mail Box is not ready for CPU to put entry into
1= Not Ready0=Ready

Bit [2] CPU gets Mail from HISC
1= Ready0=Not Ready

Bit [3] Free Mail Box has entry for CPU to get
1=Ready 0=Not Ready

Bit [31:4] Reserved

18.2.7.2 AMBX - Mail Box Access Port

Access: Zero-Wait-State, Direct Access, Write/Read

Address: h684

In write mode, CPU sends Mail to HISC

In Read mode, CPU receives Mail from HISC

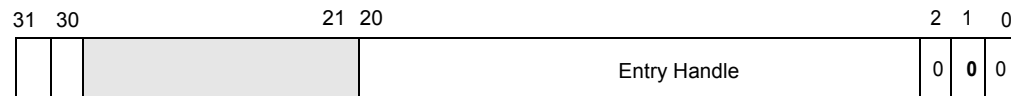

Bit [11:0] QSW[2:0] Transmission Queue Service Weight for queue 2, 1 & 0. (4 bit each)

Defines the service rate for each queue QR0-QR3

$QR0 : QR1 : QR2 : QR3$

$QR0 = QSW0 * (QSW1 + 1) * (QSW2 + 1)$

$QR1 = QSW1 * (QSW2 + 1)$

$QR2 = QSW2$

$QR3 = 1$

Note: Queue 0 has the highest priority. Queue Size is defined in the Queue Control Table

18.2.8.3 ATTL - Transmission Timing Control

Access: Non-Zero-Wait-State, Direct Access, Write/Read

Address: h650

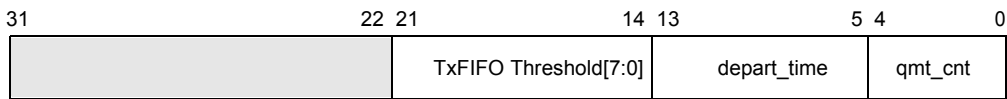

Bit [4:0] Transmission queue aging time out counter

Bit[13:5] frame latest departure time

Bit [21:14] TXFIFOT Transmission FIFO Threshold in Bytes (Default =0) Only for 100 M ports

Unit=8Bytes

0= Cut Through at the destination 100 M port

When the value does not equal zero, it indicates the port cannot start sending frames out, until the Tx FIFO reaches the threshold or EOF.

18.2.9 MII Serial Management Channel

These registers are part of the Management Module. They allow the upper layer services to communicate with any one of the PHYs that are connected to the Management Module through the serial interface.

18.2.9.1 AMIIC - MII Command Register

This is a write-only register. The upper layer services write the management frame to be sent to the PHYs into this register. The MSB (bit 31) is the first bit sent over the serial interface.

Access: Non-Zero-Wait-State, Direct Access, Write only

Address: h654

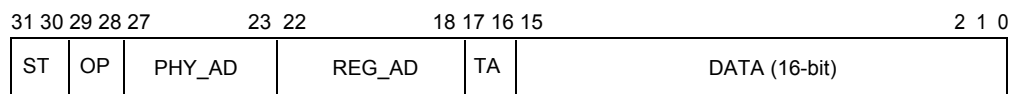

Bit [31:30] ST Start of frame - always = "01"

Bit [29:28] OP Operation code - "10" for read command and "01" for write command

Bit [27:23] PHY_AD 5-bit PHY Address

Bit [22:18]	REG_AD	5-bit Register Address in PHY
Bit [17:16]	TA	Turnaround - "10" for write
Bit [15:0]	DATA	16-bit Write Data to PHY

18.2.9.2 AMIIS - MII Status Register

The upper layer services should read this register for data sent by the PHYs. The lower 16 bits contain data received by the Management Module

Access: Non-Zero-Wait-State, Direct Access, Read only

Address: h658

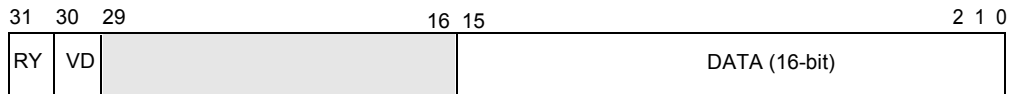

Bit [31]	RDY	Data Ready
Bit [30]	VALID	Data Valid
Bit [15:0]	DATA	16-bit Read Data from PHY

Bit [31] RDY	Bit [30] VALID	Description
1	1	Data field contains valid data from the PHYs
1	0	Data field contains invalid data from the PHYs
0	X	Data field is not ready to be read by Switch Manager CPU

18.2.10 Flow Control Management

18.2.10.1 AFCRIA - Flow Control RAM Input Address

Access: Non-Zero-Wait-State, Direct Access, Write only

Address: h65C



Bit [2:0] 3-bit address for the RAM in MAC storing flow control frame

Usage: Flow Control Frame consists of 64 Bytes. Using AFCRIA and AFCRID0-1, the CPU loads 8 bytes each time. The CPU specifies the address in AFCRIA and writes the content of 4 bytes in AFCRID0 and 4 Bytes in AFCRID1. Then repeats the above procedure 8 times to load a whole flow control frame into the Chip.

18.2.10.2 AFCRID0 - Flow Control RAM Input Data 0

Access: Non-Zero-Wait-State, Direct Access, Write only

Address: h660

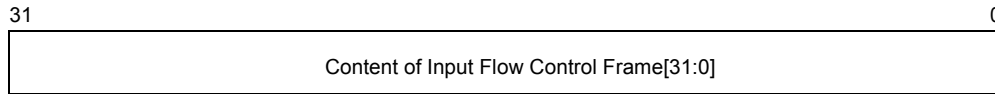

Bit [31:0] Content of flow control frame [31:0],
Flow Control Frame has 64 bytes and is defined by IEEE

18.2.10.3 AFCRID1 - Flow Control RAM Input Data 1

Access: Non-Zero-Wait-State, Direct Access, Write only

Address: h664

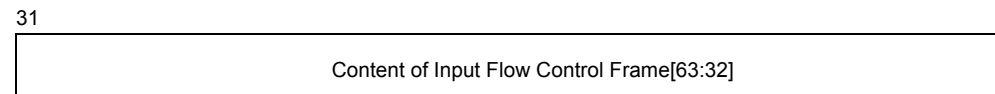

Bit [31:0] Content of flow control frame [63:32]

18.2.10.4 AFCR - Flow Control Register

Access: Non-Zero-Wait-State, Direct Access, Write/Read

Address: h670

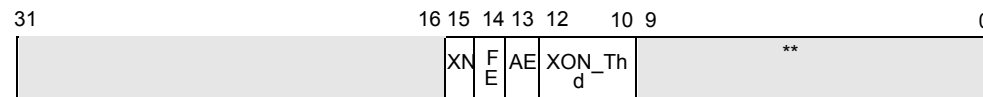

Bit [9:0] Reserved

Bit [12:10] XON_Thd Defines the minimum # of free Frame Buffers before transmitting XON flow control frame.

$$XON_Thd = \left\lfloor \frac{\text{min. \# of free FCB}}{8} \right\rfloor$$

Bit [13] Queue Aging Enable TX queue aging function enable

Bit [14] Flush Enable When stack is full, enable flush procession

0 = disable 1 = enable

Bit [15] XON Enable Full Duplex XON enable

0 = disable 1 = enable

Bit [31:16] Reserved

18.2.10.5 AMAR[1:0] - Multicast Address Reg. For MAC Control Frames

This 6-byte MAC Address is stored in two 32-bit registers

- AMAR0 MAC Address Byte [3:0]
- Address: h674
- AMAR1 MAC Address Byte [5:4]
- Address: h678

Access: Non-Zero-Wait-State, Direct Access, Write/Read

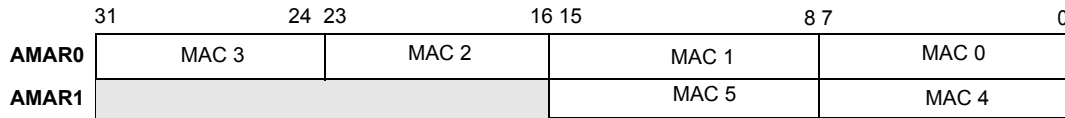

18.2.10.6 AMCT - MAC Control Frame Type Code Register

Access: Non-Zero-Wait-State, Direct Access, Write/Read

Address: h67C

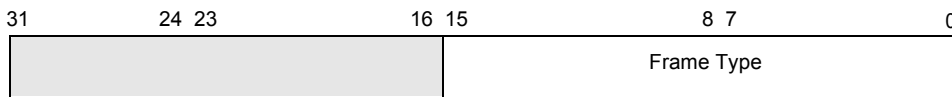

- 2-byte MAC Control Frame Type Code defined by IEEE 802.3X Full Duplex Flow Control Standard

18.2.10.7 ADAR [1:0] - Base MAC Address Registers

The 6-byte MAC Address is stored in two 32-bit registers

- ADAR0 MAC Address Byte [3:0]
- Address: h600
- ADAR1 MAC Address Byte [5:4]
- Address: h604

Access: Non-Zero-Wait-State, Direct Access, Write/Read

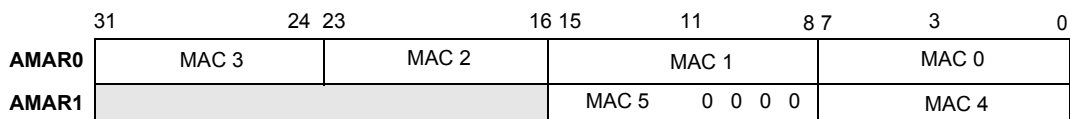

- These two registers define the base MAC address of the device.
- Bit [3:0] of Byte 0 (MAC5) is always set to 0.
- MAC address for each port is defined by
 - MAC Address for Port n = Base MAC Address + MAC Offset [n] where n = {0..12}
 - MAC Offset[n] is defined by the following registers

18.2.10.8 ADAOR0 - MAC Offset Address Register 0

MAC Offset Address for Port [7:0], 4-bit per port

Access: Non-Zero-Wait-State, Direct Access, Write/Read

Address: h608

31	28	27	24	23	20	19	16	15	12	11	8	7	4	3	0			
Port7_offset				Port6_offset			Port5_offset			Port4_offset		Port3_offset		Port2_offset		Port1_offset		Port0_offset

- Bit [3:0] MAC Offset address for Port 0
- Bit [7:4] MAC Offset address for Port 1
- Bit [11:8] MAC Offset address for Port 2
- Bit [15:12] MAC Offset address for Port 3
- Bit [19:16] MAC Offset address for Port 4
- Bit [23:20] MAC Offset address for Port 5
- Bit [27:24] MAC Offset address for Port 6
- Bit [31:28] MAC Offset address for Port 7

Usage: There are three ways to assign the MAC address to each port. All ports in the same device share the 44 MSBs, MAC[47:4] in ADAR[0:1], while the 4 LSBs, MAC Offset [3:0] can be assigned as follows:

- In a managed system, if the device does not support port trunking, MAC_Offset[3:0]= the port number.
- In a managed system where device supports port trunking, the ports in the same trunk group shares the same MAC[3:0]. The value of MAC[3:0] is assigned by the smallest port number in the Trunk Group.
- In a managed system, if BIT [18] of DCR2, SMAC=0, all ports are assigned to a single MAC.
- In an unmanaged system, MAC[3:0] is fixed for all devices (i.e., only one MAC[3:0] address for the whole system).

18.2.10.9 ADAOR1 - MAC Offset Address Register 1

MAC Offset Address for Port [12:8], 4-bit per port

Access: Non-Zero-Wait-State, Direct Access, Write/Read

Address: h60C

31	20	19	16	15	12	11	8	7	4	3	0		
				Port12_offset		Port11_offset		Port10_offset		Port9_offset		Port8_offset	

- Bit [3:0] MAC Offset address for Port 8
- Bit [7:4] MAC Offset address for Port 9
- Bit [11:8] MAC Offset address for Port 10
- Bit [15:12] MAC Offset address for Port 11
- Bit [19:16] MAC Offset address for Port 12
- Bit [31:20] Reserved

18.2.10.10 ACKTM - Timer For SOF Checking

Access: Non-Zero-Wait-State, Direct Access, Write/Read

Address: h610

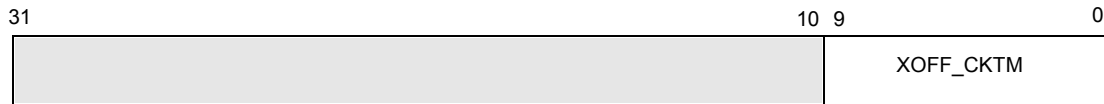

Bit [9:0] XOFF_CKTM The time out value to check SOF after XOFF

Bit [31:10] Reserved

Note that the purpose of this timer is to avoid continuously sending the XOFF frames. The XOFF Frame is triggered by the incoming frames when no resources are available in the DS chip. Ideally, after the first XOFF frame is sent out, we expect no frames to be received until we send out the XON frame. However, the connected device may not interpret XOFF frames correctly (or may react slowly) and still keep sending data frames to this congested port. In this case, the congested port will want to send another XOFF frame each time another frame is received. To avoid this scenario, we set the ACKTM timer to prevent the congested port from sending XOFF frames for every incoming frame in congestion period before the timer expires.

18.2.10.11 AFCHT10 - Flow Control Hold Time Of 10Mbps Port

Access: Non-Zero-Wait-State, Direct Access, Write/Read

Address: h620

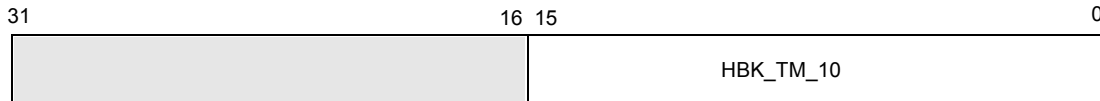

Bit [15:0] HBK_TM_10 Holding time to remote station for 10 Mbps port when the chip detects the head of line blocking counter has run out. The holding time value is embedded in the flow control frame sent to the remote station.

Bit [31:16] Reserved

18.2.10.12 AFCHT 100 - Flow Control Hold Time Of 100Mbps Port

Access: Non-Zero-Wait-State, Direct Access, Write/Read

Address: h624

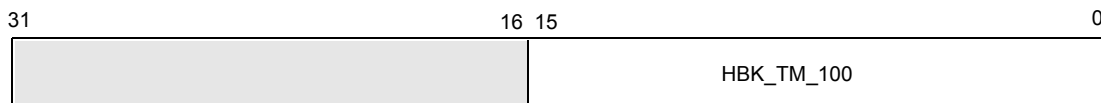

Bit [15:0] HBK_TM_100 Holding time to remote station for 100 Mbps port when the chip detects the head of line blocking counter has run out. The holding time value is embedded in the flow control frame sent to the remote station.

Bit [31:16] Reserved

18.2.10.13 AFCHT1000 - Flow Control Hold Time of Giga Port

Access: Non-Zero-Wait-State, Direct Access, Write/Read

Address: h628

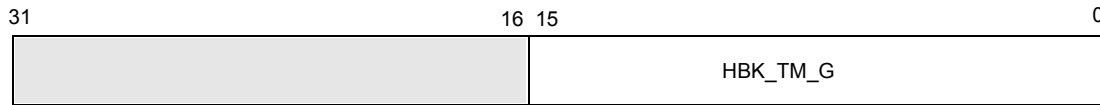

Bit [15:0] HBK_TM_G

Holding time to remote station for 1000 Mbps port when the chip detects the head of line blocking counter has run out. The holding time value is embedded in the flow control frame sent to the remote station.

Bit [31:16] Reserved

18.2.10.14 AFCOFT10 - Flow Control Off Time of 10Mbps PROT

Access: Non-Zero-Wait-State, Direct Access, Write/Read

Address: h614

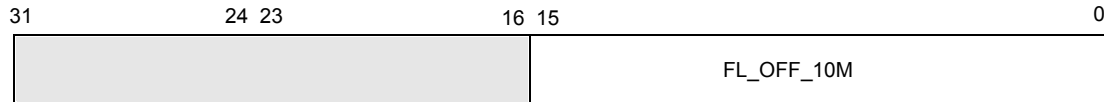

Bit [15:0] FL_OFF_10M

Off time to the remote station for 10 Mbps Port when the chip detects the buffer resource is not available. The OFF time value is embedded in the flow control frame sent to the remote station.

Bit [31:16] Reserved

18.2.10.15 AFCOFT100 - Flow Control Off Time of 100Mbps PORT

Access: Non-Zero-Wait-State, Direct Access, Write/Read

Address: h618

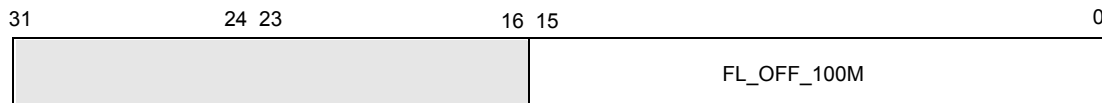

Bit [15:0] FL_OFF_100M

Off time to remote station for 100 Mbps Port when the chip detects the buffer resource is not available. The OFF time value is embedded in the flow control frame sent to the remote station.

Bit [31:16] Reserved

18.2.10.16 AFcoFT1000 - Flow Control Off Time of Giga Port

Access: Non-Zero-Wait-State, Direct Access, Write/Read
 Address: h61c

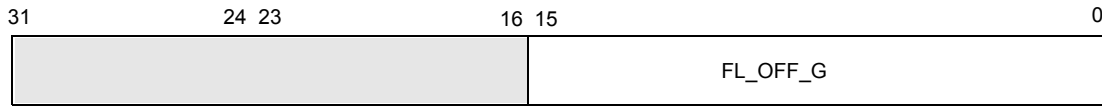

Bit [15:0] FL_OFF_G Off time to remote station for 1000 Mbps Port when the chip detects the buffer resource is not available. The OFF time value is embedded in the flow control frame sent to the remote station.

Bit [31:16] Reserved

18.2.11 Access Control Function Group 2 (Chip Level)

18.2.11.1 APMR- PORT MIRRORING REGISTER

Access: Non-Zero-Wait-State, Direct Access, Write/Read
 Address: h5C0

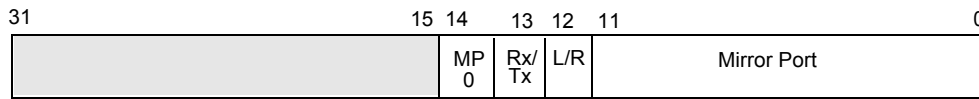

Bit [11:0] Mirr_Port The 10/100 port chosen to be mirrored

Bit [12] Local/Remote Indicates the mirrored port is from a local or remote device.
 0=local 1=remote

(Note Not support 1G port Mirroring.)

Bit [13] Rx/Tx Indicates whether the mirror is receiving data or transmitting data

Bit [14] MP0 Mirror to Port 0 (Default=0)
 MP0=1 Mirror to port 0
 MP0=0 Mirror not go to port 0

Bit [31:15] Reserved

18.2.11.2 PFR - Protocol Filtering Register

Access: Non-Zero-Wait-State, Direct Access, Write/Read
 Address: h5C4

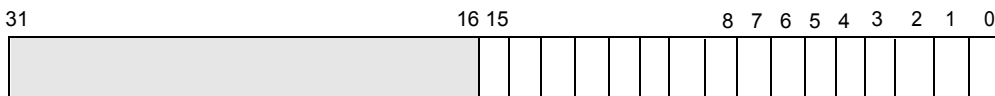

The Search Engine will provide ingress filtering on a per-devise basis. Each bit of PF register (default value = 0) will cause packets matching that category to be dropped.

Bit [7:0]	Protocol Filter for Unicast Frames
Bit [0]	IP - Ethernet II encapsulation
Bit [1]	IP - 802_SNAP encapsulation
Bit [2]	IPX - Ethernet II encapsulation
Bit [3]	IPX - 802_SNAP encapsulation
Bit [4]	IPX - 802.2 encapsulation
Bit [5]	IPX - 802.3_RAW encapsulation
Bit [6]	Other (Packets with unknown encapsulation, or non-IP, non-IPX packets)
Bit [7]	Untagged Frames
Bit [15:8]	Protocol Filter for Multicast Frames
Bit [8]	Multicast IP - Ethernet II encapsulation
Bit [9]	Multicast IP - 802_SNAP encapsulation
Bit [10]	Multicast IPX - Ethernet II encapsulation
Bit [11]	Multicast IPX - 802_SNAP encapsulation
Bit [12]	Multicast IPX - 802.2 encapsulation
Bit [13]	Multicast IPX - 802.3_RAW encapsulation
Bit [14]	Multicast Other (Packets with unknown encapsulation, or non-IP, non-IPX packets)
Bit [15]	Multicast Untagged Frames
Bit [31:16]	Reserved

Usage: There is only one PFR register. For each port there is an enable bit(ECR1 bit 6: IFE- Ingress filter Enable) which determines whether the settings in PFR are applied to that port.

18.2.11.3 THKM [0:7] - Trunking Forwarding Port Mask 0-7

Eight Trunking Hash Key Mask Registers shared the same format.

- **THKM0** Trunking Forwarding Port Mask 0 Forwarding Port mask for hash key 0
Address:h5C8
 - **THKM1** Trunking Forwarding Port Mask 1 Forwarding Port mask for hash key 1
Address:h5CC
 - **THKM2** Trunking Forwarding Port Mask 2 Forwarding Port mask for hash key 2
Address:h5D0
 - **THKM3** Trunking Forwarding Port Mask 3 Forwarding Port mask for hash key 3
Address:h5D4
 - **THKM4** Trunking Forwarding Port Mask 4 Forwarding Port mask for hash key 4
Address:h5D8
 - **THKM5** Trunking Forwarding Port Mask 5 Forwarding Port mask for hash key 5
-

Address:h5DC

- **THKM6** Trunking Forwarding Port Mask 6 Forwarding Port mask for hash key 6

Address:h5E0

- **THKM7** Trunking Forwarding Port Mask 7 Forwarding Port mask for hash key 7

Address:h5E4

Access: Non-Zero-Wait-State, Direct Access, Write/Read

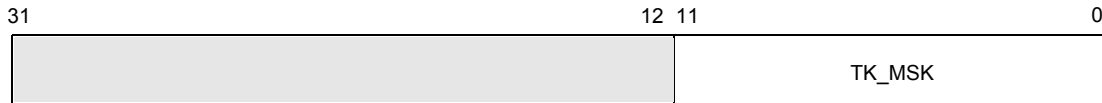

Bit [11:0] TK_MSK Port trunk mask for trunking hash key

Bit [31:12] Reserved

CPU sets up this table as follows:

1. Set all bits not in Trunk Groups to 1
2. Set all bits in the Trunk Group to 0
3. Pick one forwarding port per trunk group and turn the corresponding bit to 1 (Each Hash Key may have different forwarding ports, the rule to pick forwarding ports is up to the CPU).

Usage: These masks are used to prevent flooded or multicast packets from being transmitted out with more than one port on a trunk. The Trunking Hash Key is used to select the proper mask (for load distribution). The mask value will be set up to mask off all but one port within each trunk group.

18.2.11.4 IPMCAS - IP Multicast MAC Address Signature

Usage: For following four registers IPMCAS0, IPMCAS1, IPMCMSK0 and IPMCMSK1, are used to distinguish between IP multicast traffic and regular multicast. The MAC for IP multicast are h"01:00:5e:00:00:00" to h"01:00:5e:7f:ff:ff" And the MASK for IPMC is: h"ff:ff:ff:80:00:00".

The 6-byte of IP multicast MAC Address is stored in two 32-bit registers

- **IPMCAS0** IP Multicast MAC Address Byte [3:0]

Address:h5E8

- **IPMCAS1** IP Multicast MAC Address Byte [5:4]

Address:h5EC

Access: Non-Zero-Wait-State, Direct Access, Write/Read

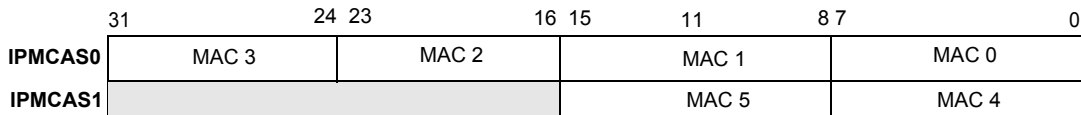

- These two registers define the MAC address signature of IP multicast.
- Default = h" 01:00:5e:7f:ff:ff"

18.2.11.5 IPMCMSK- IP Multicast MAC Address Mask

The 6-byte of IP multicast MAC Mask is stored in two 32-bit registers

- **IPMCAS0** IP Multicast MAC Mask Byte [3:0]

Address:h5F0

- **IPMCAS1** IP Multicast MAC Mask Byte [5:4]

Address:h5F4

Access: Non-Zero-Wait-State, Direct Access, Write/Read

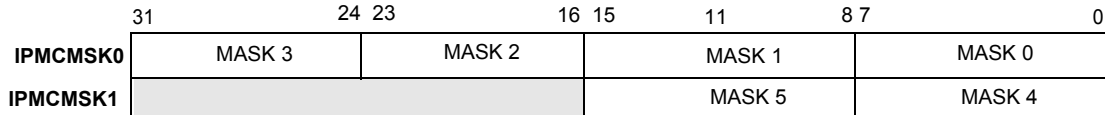

These two registers define the MAC Mask of IP multicast.

Default = h"ff:ff:ff:80:00:00".

18.2.11.6 CFCBHDL - FCB Handle Register For CPU Read

Access: Non-Zero-Wait-State, Direct Access, Read only

Address: h580

Usage: When CPU requests a free FDB to write a frame, it must request a free FCB via this register. The register contains a free handle of FCB, which also pointer to a free FDB.

CPU reads FCB Handle: (When the CPU write FDB, it requires a FDB handle first).

CPU checks CFCBHDL[31],H_RDY ready or not. If so, CPU gets the FCB Handle from CFCBHDL[9:0]



Bit [9:0] FCB_HANDLE FCB Handle Address

Bit [30:10] Reserved

Bit [31] H_RDY FCB Handle Ready

0=Not Ready 1=Ready

18.2.11.7 CPU Access Internal RAMs (Tables)

Usage: (refer to section 9 for detail).

The CPU uses the following methods to access the five internal RAMs, including MCID, VLAN port mapping (VMAP), BM control Table (BMCT), FCB and Transmission Queue control (QCNT).

Registers:

- **CPUIRCMD**: Command register
- **CPUIRDAT0**: Data Register for specific entry of content Bit[31:0]
- **CPUIRDAT1**: Data Register for specific entry of content Bit[63:32]
- **CPUIRDAT2**: Data Register for specific entry of content Bit[95 64]
- **CPUIRRDY**: Data Read Ready.

18.2.11.9 CPUIRDAT - CPU INTERNAL RAM DATA REGISTER

The 3 data registers are used when CPU reads or writes the content of the specified entry. table

- CPUIRDAT0 CPU Internal RAM Data register for Data[31:0]

Address: h588

- CPUIRDAT1 CPU Internal RAM Data register for Data[63:32]

Address: h58C

- CPUIRDAT2 CPU Internal RAM Data register for Data[95:64]

Address: h590

Access: Non-Zero-Wait-State, Direct Access, Write/Read

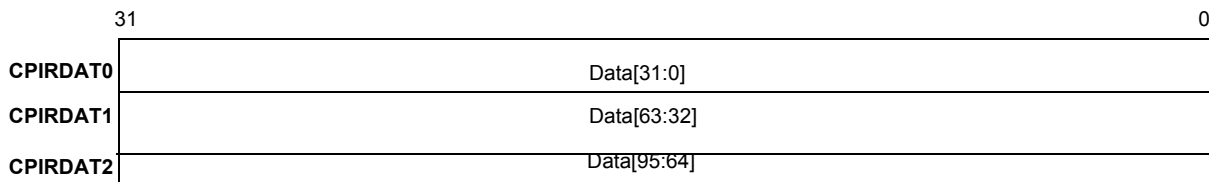

The content is dependent as to the type of table, as describe follows.

Type = MC ID (6bits)



Bit [5:0] MCID multicast ID FIFO data output
(Note that up to 16 for this version.)

Bit [31:6] Reserved

Type = VMAP Table (27 bits)

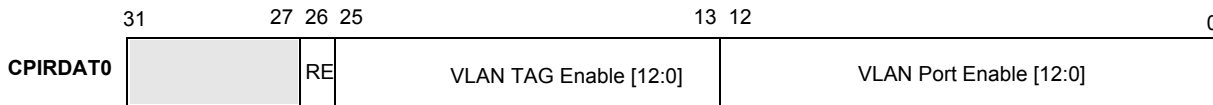

Bit [12:0] VLAN Port Enable [12:0] one bit for each Ethernet MAC Port
Identify the ports associated with each VLAN
0 = disable 1 = enable

Bit [25:13] VLAN Tag Enable [12:0] one bit for each Ethernet MAC Port
0 = disable 1 = enable

Bit [26] RE Remote Ports Enable: Indicate some members in the remote device.

Bit [31:27] Reserved 0=disable1=enable

Type = BMCT (12bits)

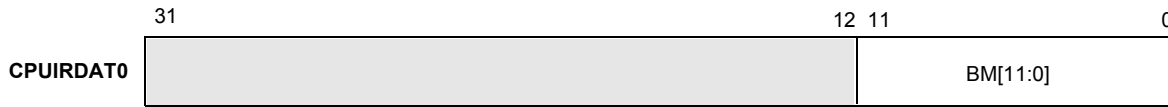

Bit [11:0] BM Buffer Management control FIFO Output
 BM stores free FCB handles. (FCB handle=0 cannot be used.)

Bit [31:12] Reserved

Type = FCB (56 bits)

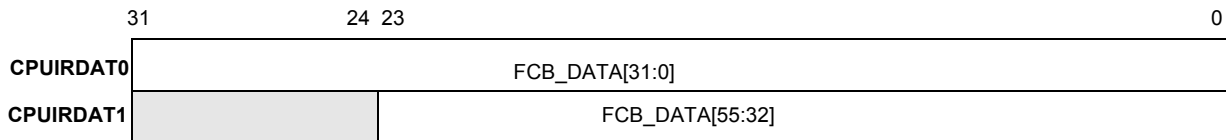

Bit [55:0] FCB Frame Control Block.
 Refer to Chapter 9 for detailed data structure.

Type = QCNT (79 bits)

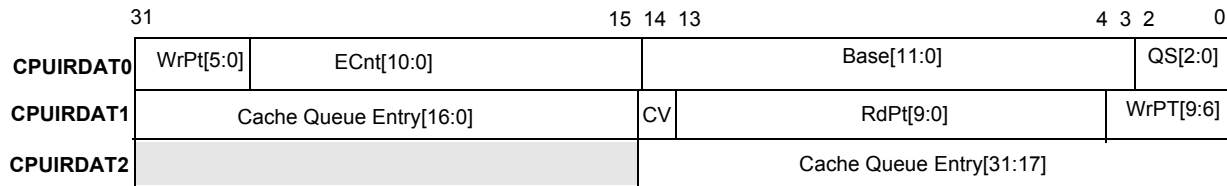

Bit [2:0] Que_S [2:0] Queue size
 000=128 entries 001=128*2 entries
 111=128*8=1K entries
 Each entry contains 4 bytes

Bit [14:3] Base [11:0] Base pointer to its Transmission Queue

Bit [25:15] ECnt [10:0] Entry Count: Total entries in its queue.

Bit [35:26] WrPt [9:0] Write Pointer
 Address_Write_Entry[20:9]=Base[11:0]+WrPt[9:7]
 Address_Write_Entry[9:3]= WrPt[6:0]
 Address_Write_Entry[2:0]= 0
 (The address [2:0] is always equal to 0.)

Bit [45:36] RdPt [9:0] Read Pointer
 Address_Read_Entry[20:9]=Base[11:0]+RdPt[9:7]
 Address_Read_Entry[9:3]= RdPt[6:0]
 Address_Read_Entry[2:0]= 0 (The address [2:0] is always equal to 0.)

Bit[46] CV Cache Valid
 CV=1, Cache of Queue Entry QE[31:0] is valid.

Bit[78:47] QE[31:0] Cache a queue entry

18.2.11.10 CPUIRRDY - Internal Ram Read Ready For CPU

Access: Non-Zero-Wait-State, Direct Access, Write/Read

Address: h594

The Frame Engine sets this ready bit to notify the CPU that the requested data is ready to read.



Bit [0] R_RDY Data in Data registers is ready for CPU Read

Bit [31:1] Reserved

18.2.11.11 LEDR- LED Register

Access: Non-Zero-Wait-State, Direct Access, Write/Read

Address: h598

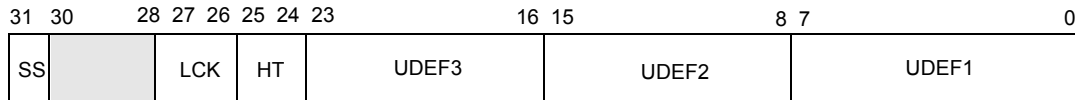

Bit [7:0] UDEF1 User defined information status 1 for debug purpose

Bit [15:8] UDEF2 User defined information status 2 for debug purpose

Bit [23:16] UDEF3 User defined information status 3 for debug purpose

Bit [25:24] HT Holding time for LED signal (Default=00)

00=8msec 01=16msec

10=32msec 11=64msec

Bit [27:26] LCLK LED Clock frequency (Default=00)

00= 100M/8=12.5Mhz 01= 100M/16=6.25Mhz

10= 100M/32=3.125Mhz 11= 100M/64=1.5625Mhz

Bit [30:28] Reserve

Bit [31] SS Start Shift the status bits out from the master device.

This bit has no effect on the slave chip.

Note: UDEF1-UDEF3 are used for debug purpose. The contents of UDEF1-3 are loaded by CPU and the usage of these are up to software.**18.2.12 Ethernet MAC Port Control Registers**

One set for each Ethernet MAC Port [12:0]

MII related controls applies to Port [1:0] only

Port 12 is always dedicated to GMAC

18.2.12.1 ECR0 - ECR0 - MAC Port Control Register

Access: Non-Zero-Wait-State, Direct Access, Write/Read

Address: h0x0*4 x: port n

h000	ECR0_p0
h040	ECR0_p1
h080	ECR0_p2
h0c0	ECR0_p3
h100	ECR0_p4
h140	ECR0_p5
h180	ECR0_p6
h1c0	ECR0_p7
h200	ECR0_p8
h240	ECR0_p9
h280	ECR0_p10
h2c0	ECR0_p11
h300	ECR0_p12



Bit [0]	RR	Reset Receiver
Bit [1]	XR	Reset Transmitter
Bit [2]	RE	RX Enable
Bit [3]	RP	RST_PCS, Reset PCS logic (Only apply Gigabit Port)

Port is disabled when both RR & XR bits are set.

18.2.12.2 ECR1 - MAC Port Configuration Register

Access: Non-Zero-Wait-State, Direct Access, Write/Read

Address: h0x1*4x: port number

h004	ECR1_p0
h044	ECR1_p1
h084	ECR1_p2
h0c4	ECR1_p3
h104	ECR1_p4
h144	ECR1_p5

h184	ECR1_p6
h1c4	ECR1_p7
h204	ECR1_p8
h244	ECR1_p9
h284	ECR1_p10
h2c4	ECR1_p11
h304	ECR1_p12

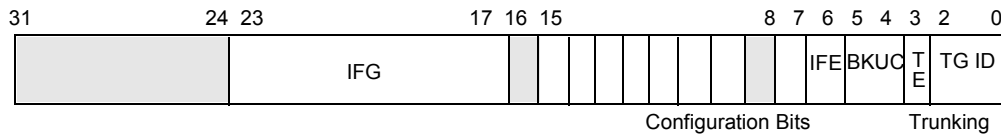

Port Trunking ID Bits

Bit [2:0]	TGID	Group ID
Bit [3]	TE	Trunk Enable
		0= Trunk disable 1= Trunk Enable

Unicast Blocking Control Bits

Bit [5:4]	Block_UC_Frame	Instructs the Rx MAC to discard incoming Unicast Frames. This feature is used by Spanning Tree.
		0X Blocking, all frames (Default state)
		10 Learning but not forwarding
		11 Forwarding all frames
Bit [6]	IFE	Ingress Filter Enable Default = 0
		Used to enable protocol filtering on a port by port basis. There is only one Protocol Filtering Register (PFR), but it can be used on any combination of ports.
		0= disable ingress filter 1= enable ingress filter

Physical Layer Control Bits

Bit [7]	10M	10M or 100M; 1=10Mbps 0=100Mbps
Bit [8]	Reserved	
Bit [9]	Full_Duplex	Enables full duplex mode Default =0 - Half Duplex
Bit [10]	FDX_Polarity	Selects the output polarity of Full_Duplex control signal
		0 = Low true (Default) 1 = High true
Bit [11]	Int_Lpback	Setting this bit cause internal connect
		TXCLK, TXD, TXD[0:3] to RXCLK, RXD, RXD[0:3]

		Default =0 - Disable
Bit [12]	Ext_Lpback	Setting this bit indicate an external loop-back (connection of TXCLK, TXD[0:3] to RXCLK, RXD[0:3] are required) Default =0 -- Disable
Bit [13]	FC_Enable	Flow Control EnableDefault =0 - Disable
When enabled:		
<ul style="list-style-type: none"> • In Half Duplex mode, the MAC Transmitter applies back pressure for flow control. • In Full Duplex mode, the MAC Transmitter sends Flow-Control frames when necessary. The MAC Receiver interprets and processes incoming Flow Control frames. The MAC Receiver marks all Flow Control Frames. Receive DMA discards the received Flow Control Frame and send status reports to the Switch Manager for statistic collection. 		
When Disabled:		
<ul style="list-style-type: none"> • The MAC Transmitter does not asserts flow control by sending Flow Control frames nor jamming collision. • The MAC Receiver still interprets and processes the Flow-Control frames. The MAC Receiver marks all Flow Control frames. Receive DMA discards the received Flow Control frames and send a status report to the Switch Manager for statistic collection. 		
Bit [14]	Link_Polarity	Selects the input polarity of Link Status signal 0 = Low true (Default) 1 = High true
Bit [15]	Tx_Enable	Enables MAC Transmitter for transmission Default =0 - Disable
Bit [16]	Reserved	
Bit [23:17]	IFG	Inter-frame Gap (Default=7'd24) Use to adjust the inter-frame gap. (Unit =transmit Clock.) The default is 7'd24, stands for 24 transmit clock (each clock transmit 4 bits).
Bit [31:24]	Reserved	

18.2.12.3 ECR2 - MAC Port Interrupt Mask Register

Access:	Non-Zero-Wait-State,	Direct Access,	Write/Read
Address:	h0x2*4	x: port number	
	h008	ECR2_p0	
	h048	ECR2_p1	
	h088	ECR2_p2	
	h0c8	ECR2_p3	
	h108	ECR2_p4	

h148	ECR2_p5
h188	ECR2_p6
h1c8	ECR2_p7
h208	ECR2_p8
h248	ECR2_p9
h288	ECR2_p10
h2c8	ECR2_p11
h308	ECR2_p12

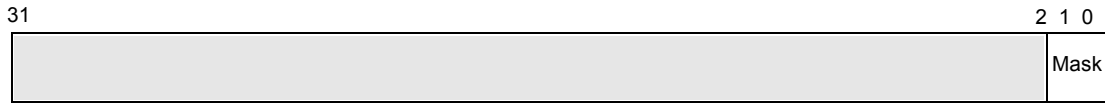

Bit [0]	WAS	If set, the status counter wrap around signal is masked.
Bit [1]	Link_Change	If set, the Link_Up and Link_Down Interrupts are masked.
Bit [31:2]	Reserved	

Link Change interrupts are automatically disabled whenever both MAC Transmitter & Receiver are in Reset state - i.e. both XR & RR bits are set.

18.2.12.4 ECR3 - MAC Port Interrupt Status Register

Access: Non-Zero-Wait-State, Direct Access, Read only

Address:h0x3*4 x: port number

h00c	ECR3_p0
h04c	ECR3_p1
h08c	ECR3_p2
h0cc	ECR3_p3
h10c	ECR3_p4
h14c	ECR3_p5
h18c	ECR3_p6
h1cc	ECR3_p7
h20c	ECR3_p8
h24c	ECR3_p9
h28c	ECR3_p10
h2cc	ECR3_p11
h30c	ECR3_p12

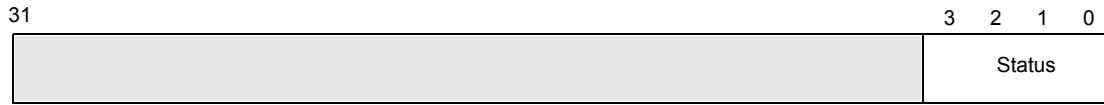

Bit [0]	WAS	Wrapped around signal.
Bit [1]	Link_Change	This bit is set when the MAC determines that the status of physical link has been changed
Bit [2]	LK_UP	0=Link Down, 1=Link UP This bit is reset whenever the PHY has identified the lost of physical link integrity.
Bit [31:3]	Reserved	

18.2.12.5 ECR4 - Port Status Counter Wrapped Signal

Access: Non-Zero-Wait-State, Direct Access, Read only

Address:	h0x4*4	x: port number
	h010	ECR4_p0
	h050	ECR4_p1
	h090	ECR4_p2
	h0d0	ECR4_p3
	h110	ECR4_p4
	h150	ECR4_p5
	h190	ECR4_p6
	h1d0	ECR4_p7
	h210	ECR4_p8
	h250	ECR4_p9
	h290	ECR4_p10
	h2d0	ECR4_p11
	h310	ECR4_p12

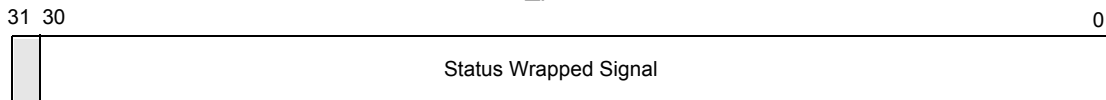

B[0].	0-d	Bytes Sent(D)
B[1].	1-L	Unicast Frames Sent
B[2].	1-U	Flow Control Sent

B[3].	2-l	Non-unicast frame sent
B[4].	2-U1	frame send fail
B[5].	2-U2	Alignment Error
B[6].	3-d	Bytes Received (Good or Bad) (D)
B[7].	4-d	Frames Received (Good or Bad) (D)
B[8].	5-d	Total Bytes Received (Good) (D)
B[9].	6-L	Total Frames Received (Good)
B[10].	6-U	Flow Control Frames Received
B[11].	7-l	Multicast Frames Received
B[12].	7-u	Broadcast Frames Received
B[13].	8-L	Frames with length of 64 bytes
B[14].	8-U	Jabber Frames
B[15].	9-L	Frames with length between 65-127 bytes
B[16].	9-U	Oversize Frames
B[17].	A-l	Frames with length between 128-255 bytes
B[18].	A-u	Frames with length between 256-511 bytes
B[19].	B-l	Frames with length between 512-1023 bytes
B[20].	B-u	Frames with length between 1024-1528 bytes
B[21].	C-l	Undersize Frames
B[22].	C-u	Fragment
B[23].	D-l	CRC
B[24].	D-u	Short Event
B[25].	E-l	Collision
B[26].	E-u	Drop
B[27].	F-l	Filtering Counter
B[28].	F-U1	Delay exceed discard counter
B[29].	F-U2	Late Collision

Note: Each port owns a counter block, containing 16 double words. The 29 bits indicate that each corresponding counter is wrapping around the signal. The type and location of each counter is specified by the following format.

The format description:

X-Y: X means the relative Physical Address in its counter blocks.

: Y indicates the type of counter it is (Notation "C"= double word read from RAM block)

D: C[31:0] double word counter

L: C[23:0] 24 bits counter

U: C[31:24] 8 bits counter

U1: C[23:16] 8 bits counter

U2: C[31:24] bits counter (the same as notation "U")

I: C[15:0] 16 bits counter

u C[31:16] 16 bits counter

18.2.12.6 PVID Register

Access: Non-Zero-Wait-State, Direct Access, Write/Read

Address: h0x9*4 x: port number

For Default VLAN ID

h024	PVIDR_p0
h064	PVIDR_p1
h0a4	PVIDR_p2
h0e4	PVIDR_p3
h124	PVIDR_p4
h164	PVIDR_p5
h1a4	PVIDR_p6
h1e4	PVIDR_p7
h224	PVIDR_p8
h264	PVIDR_p9
h2a4	PVIDR_p10
h2e4	PVIDR_p11
h324	PVIDR_p12

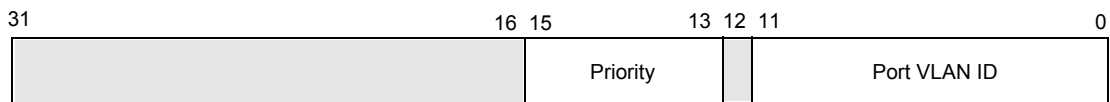

Bit [0:11] Port VLAN ID (PVID)

Bit [12] Reserved

Bit [15:13] Priority

Bit [31:16] Reserved

19.0 DC Electrical Characteristics

19.1 Absolute Maximum Ratings

Package: 456 HBGA (Heatslug BGA)

Storage Temperature: -65C to +150C

Operating Temperature: 0C to +70C

Maximum Junction Temperature:125C

Supply Voltage VCC with Respect to VSS +3.0 V to +3.6 V

Supply Voltage VDD with Respect to VSS +2.38 V to +2.75 V

Voltage on 5V Tolerant Input Pins -0.5 V to (VCC + 3.3 V)

Caution: Stresses above those listed may cause permanent device failure. Functionality at or above these limits is not implied. Exposure to the Absolute Maximum Ratings for extended periods may affect device reliability.

19.2 DC Electrical Characteristics

VCC = 3.0 V to 3.6 V (3.3v +/- 10%) $T_{AMBIENT} = 0\text{ C to }+70\text{ C}$

VDD = 2.5V +10% - 5%

Recommended Operating Conditions

Symbol	Parameter Description	Min.	Type	Max.	Unit
f_{osc}	Frequency of Operation		100		MHz
I_{CC}	Supply Current - @ 100 MHz (VCC =3.3 V)		270	351	mA
I_{DD}	Supply Current - @ 100 MHz (VDD =2.5 V)		780	1014	mA
V_{OH}	Output High Voltage (CMOS)	2.4			V
V_{OL}	Output Low Voltage (CMOS)			0.4	V
V_{IH-TTL}	Input High Voltage (TTL 5V tolerant)	2.0		VCC + 2.0	V
V_{IL-TTL}	Input Low Voltage (TTL 5V tolerant)			0.8	V
I_{IL}	Input Leakage Current (all pins except those with internal pull-up/pull-down resistors)			10	μ A
I_{OL}	Output Leakage Current			10	μ A
C_{IN}	Input Capacitance			5	pF
C_{OUT}	Output Capacitance			5	pF
$C_{I/O}$	I/O Capacitance			7	pF
θ_{ja}	Thermal resistance with 0 air flow			12 ¹	C/W
θ_{ja}	Thermal resistance with 1 m/s air flow			11	C/W
θ_{ja}	Thermal resistance with 2 m/s air flow			9.6	C/W
θ_{jc}	Thermal resistance between junction and case			3.3	C/W

Note 1: When external heat sink is attached, θ_{JA} is reduced by about 8-12% in still air.

20.0 AC Specifications

20.1 XPIPE Interface

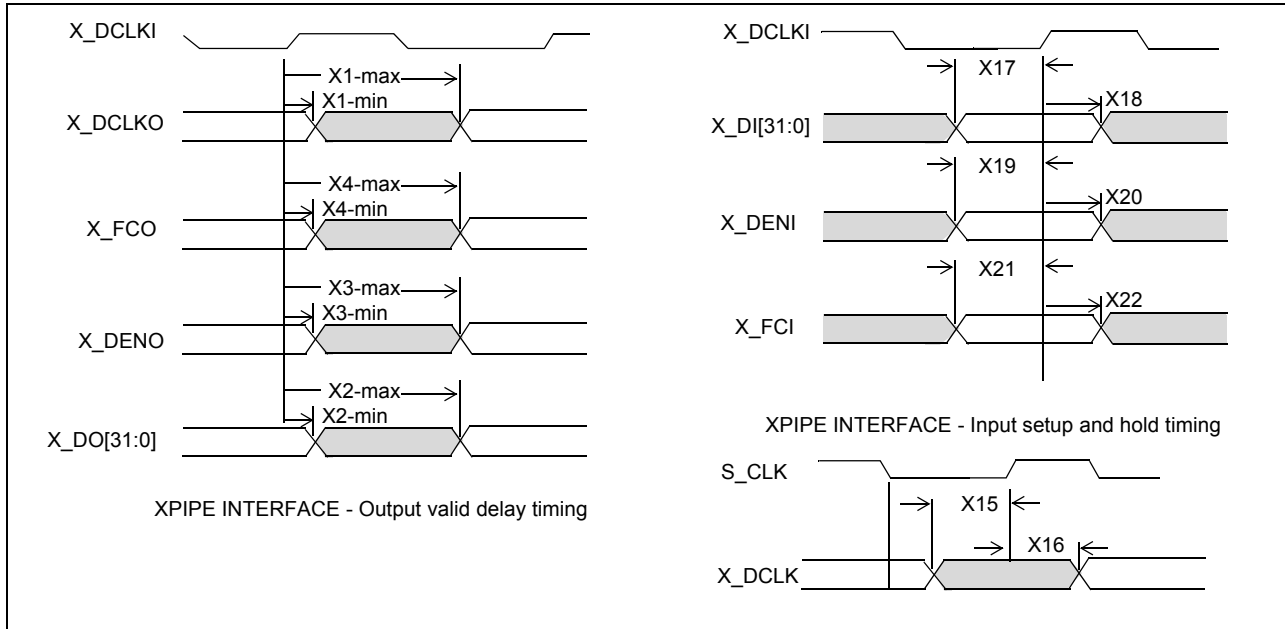

Figure 26 - XPIPE Interface - Output Valid Delay Timing

Symbol	Parameter	-100 MHZ		Note
		Min (ns)	Max (ns)	
X1	X_DCLKO output valid delay	1	5	$C_L = 30\text{pf}$
X2	X_DO[31:0] output valid delay	1	5	$C_L = 30\text{pf}$
X3	X_DENO output valid delay	1	5	$C_L = 30\text{pf}$
X4	X_FCO output valid delay	1	5	$C_L = 30\text{pf}$
X15	X_DCLKI input set-up time	3		Reference S-CLK
X16	X_DCLKI input hold time	0		Reference S-CLK
X17	X_DI[31:0] input set-up time	3		
X18	X_DI[31:0] input hold time	0		
X19	X_DENI input set-up time	3		
X20	X_DENI input hold time	0		
X21	X_FCI input set-up time	3		
X22	X_FCI input hold time	0		

Table 11 - AC Characteristics - XPipe Interface

20.2 CPU BUS Interface

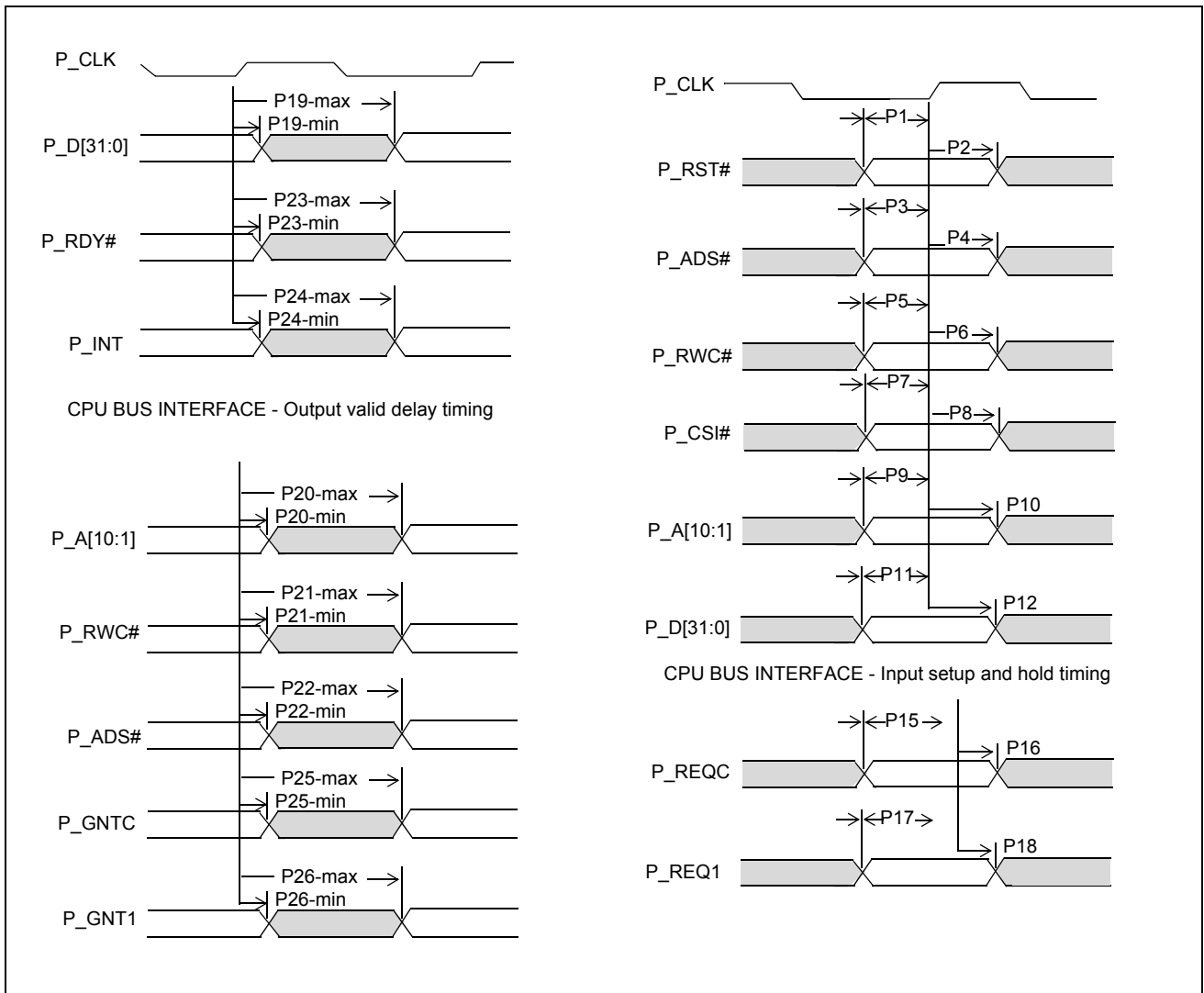

Figure 27 - AC Characteristics - CPU BUS Interface

Symbol	Parameter	-66 MHZ		Note
		Min (ns)	Max (ns)	
	P_CLK			
P1	P_RST# input setup time	6		
P2	P_RST# input hold time	2		
P3	P_ADS# input setup time	6		
P4	P_ADS# input hold time	2		
P5	P_RWC# input setup time	6		
P6	P_RWC# input hold time	2		
P7	P_CSI# input setup time	6		
P8	P_CSI# input hold time	2		
P9	P_A[10:1] input setup time	6		
P10	P_A[10:1] input hold time	2		
P11	P_D[31:0] input setup time	6		
P12	P_D[31:0] input hold time	2		
P15	P_REQC input setup time	6		
P16	P_REQC input hold time	2		
P17	P_REQI input setup time	6		
P18	P_REQI input hold time	2		
P19	P_D[31:0] output valid delay	2	12	C _L = 65pf
P20	P_A[10:1] output valid delay	2	9	C _L = 50pf
P21	P_RWC# output valid delay	2	9	C _L = 50pf
P22	P_ADS# output valid delay	2	9	C _L = 50pf
P23	P_RDY# output valid delay	2	9	C _L = 50pf
P24	P_INT output valid delay	2	9	C _L = 30pf
P25	P_GNTC output valid delay	2	9	C _L = 20pf
P26	P_GNT1 output valid delay	2	9	C _L = 20pf

Table 12 - AC Characteristics - CPU Bus Interface

20.3 Local SBRAM Memory Interface

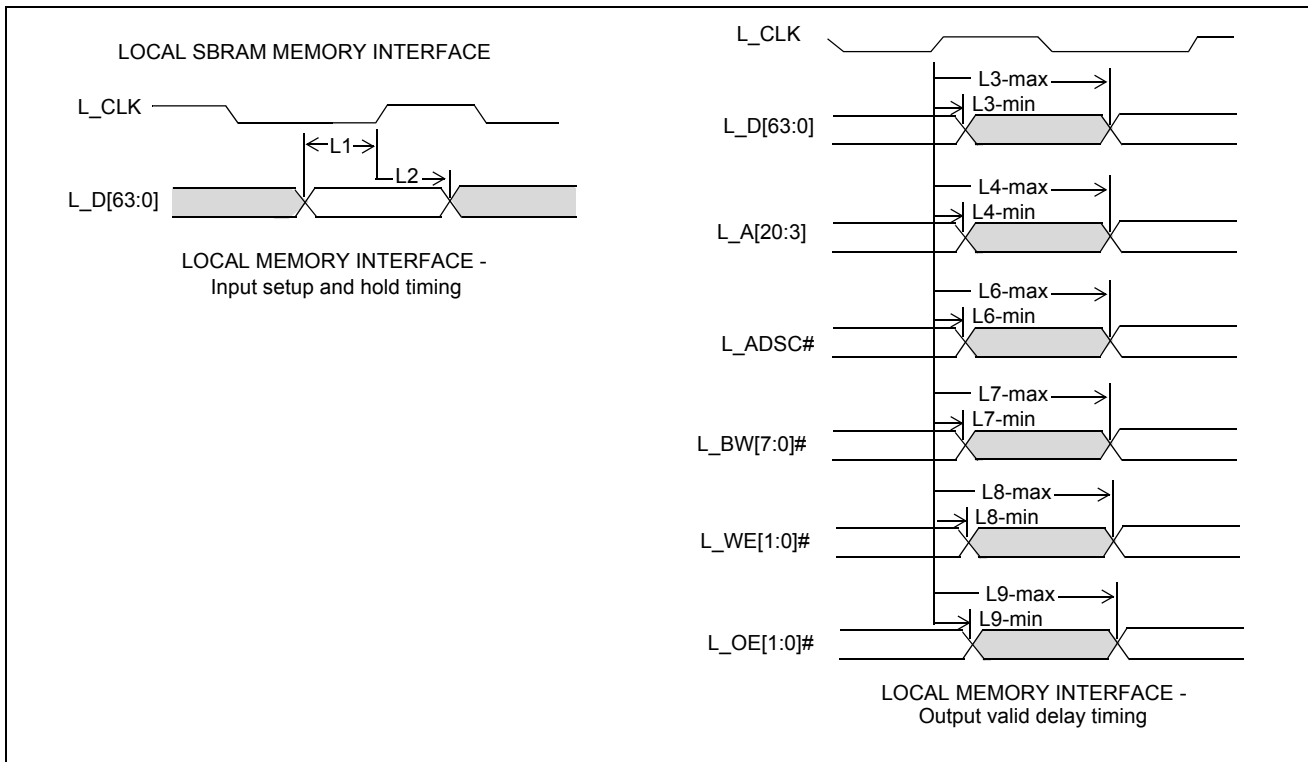

Figure 28 - Local Memory Interface - Input Setup and Output Valid Delay Timing

Symbol	Parameter	-100MHZ		Note
		Min (ns)	Max (ns)	
	L_CLK			$C_L = 50\text{pf}$
L1	L_D[63:0] input set-up time	3		
L2	L_D[63:0] input hold time	1.5		
L3	L_D[63:0] output valid delay	2	7	$C_L = 30\text{pf}$
L4	L_A[20:3] output valid delay	2	7	$C_L = 50\text{pf}$
L6	L_ADSC# output valid delay	2	7	$C_L = 50\text{pf}$
L7	L_BW[7:0]# output valid delay	2	7	$C_L = 30\text{pf}$
L8	L_WE[1:0]# output valid delay	2	7	$C_L = 30\text{pf}$
L9	L_OE[1:0]# output valid delay	0	1	$C_L = 30\text{pf}$

Table 13 - AC Characteristics - Local SBRAM Memory Interface

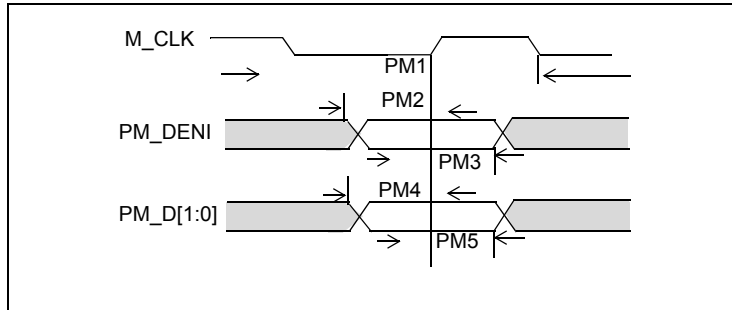

Figure 29 - Port Mirroring Interface - Input Setup and Hold Timing

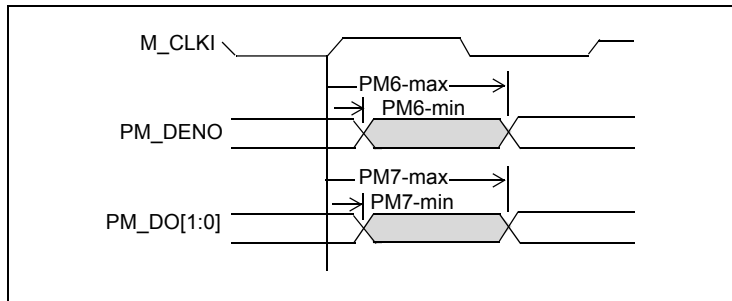

Figure 30 - Port Mirroring Interface - Output Delay Timing

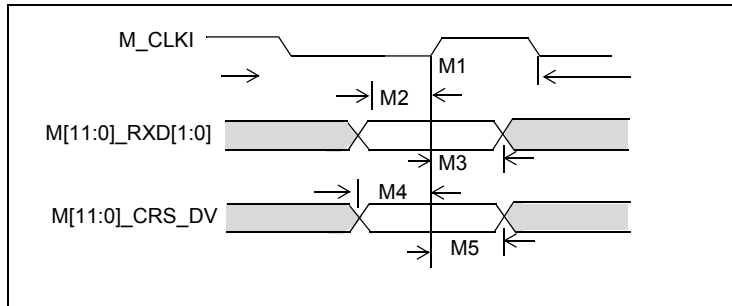

Figure 31 - Reduce Media Independent Interface - Input Setup and Hold Timing

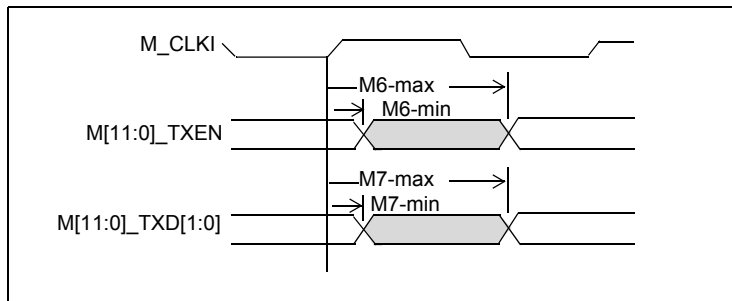

Figure 32 - Reduce Media Independent Interface - Output Delay Timing

Symbol	Parameter	-50 MHZ		Note
		Min (ns)	Max (ns)	
PM1	M_CLKI			Reference Input Clock
PM2	PM_DENI Input Setup Time	1.5		
PM3	PM_DENI Input Hold Time	2		
PM4	PM_DI[1:0] Input Setup Time	1.5		
PM5	PM_DI[1:0] Input Hold Time	2		
PM6	PM_DENO Output Delay Time	2	11	$C_L = 30\text{pf}$
PM7	PM_DO[1:0] Output Delay Time	2	11	$C_L = 30\text{pf}$

Table 14 - AC Characteristics - Port Mirroring Interface

Symbol	Parameter	-50 MHZ		Note
		Min (ns)	Max (ns)	
M1	M_CLKI			Reference Input Clock
M2	M[11:0]_RXD[1:0] Input Setup Time	1.5		
M3	M[11:0]_RXD[1:0] Input Hold Time	2		
M4	M[11:0]_CRS_DV Input Setup Time	2		
M5	M[11:0]_CRS_DV Input Hold Time	1		
M6	M[11:0]_TXEN Output Delay Time	2	11	$C_L = 30\text{pf}$
M7	M[11:0]_TXD[1:0] Output Delay Time	2	11	$C_L = 30\text{pf}$

Table 15 - AC Characteristics - Reduced Media Independent Interface

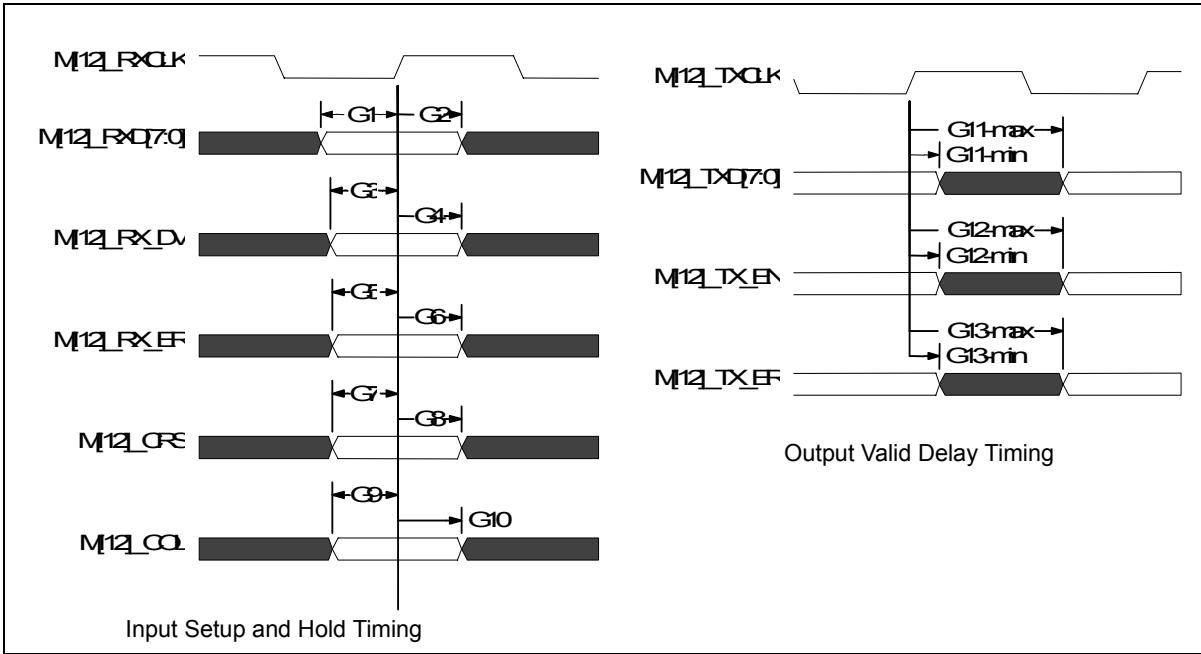

Symbol	Parameter	-125 MHZ		Note
		Min (ns)	Max (ns)	
	$M[12]_{RXCLK}$			Input Reference Clock
G1	$M[12]_{RXD[7:0]}$ Input Setup Times	2		
G2	$M[12]_{RXD[7:0]}$ Input Hold Times	0		
G3	$M[12]_{RXDV}$ Input Setup Times	2		
G4	$M[12]_{RXDV}$ Input Hold Times	0		
G5	$M[12]_{RXER}$ Input Setup Times	2		
G6	$M[12]_{RXER}$ Input Hold Times	0		
G7	$M[12]_{CRS}$ Input Setup Times	2		
G8	$M[12]_{CRS}$ Input Hold Times	0		
G9	$M[12]_{COL}$ Input Setup Times	2		
G10	$M[12]_{COL}$ Input Hold Times	0		
	$M[12]_{TXCLK}$			Output Reference Clock
G11	$M[12]_{TXD[7:0]}$ Output Delay Times	1	5	$C_L = 20\text{pf}$
G12	$M[12]_{TXEN}$ Output Delay Times	1	5	$C_L = 20\text{pf}$
G13	$M[12]_{TXER}$ Output Delay Times	1	5	$C_L = 20\text{pf}$

Table 16 - AC Characteristics - Gigabit Media Independent Interface

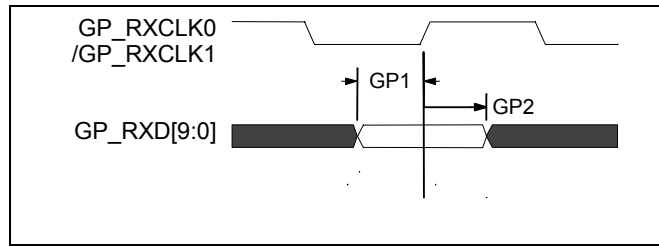

Figure 33 - Input Setup and Hold Timing

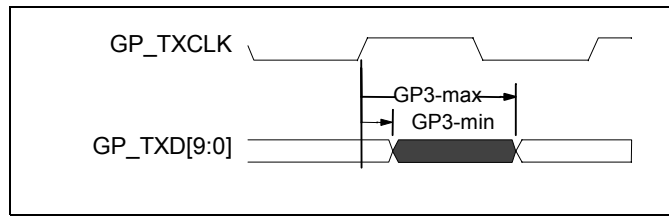

Figure 34 - Output Valid Delay Timing

Symbol	Parameter	-125 MHZ		Note
		Min (ns)	Max (ns)	
	GP_RXCLK0/ GP_RXCLK1			Input Reference Clock
GP1	GP_RXD[9:0] Input Setup Times	2		
GP2	GP_RXD[9:0] Input Hold Times	0		
	GP_TXCLK			Output Reference Clock
GP3	GP_TXD[9:0] Output Delay Times	1	5	$C_L = 20\text{pf}$

Table 17 - AC Characteristics - Physical Media Attachment Interface

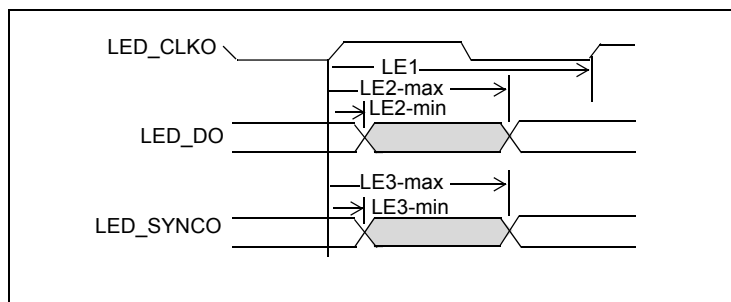
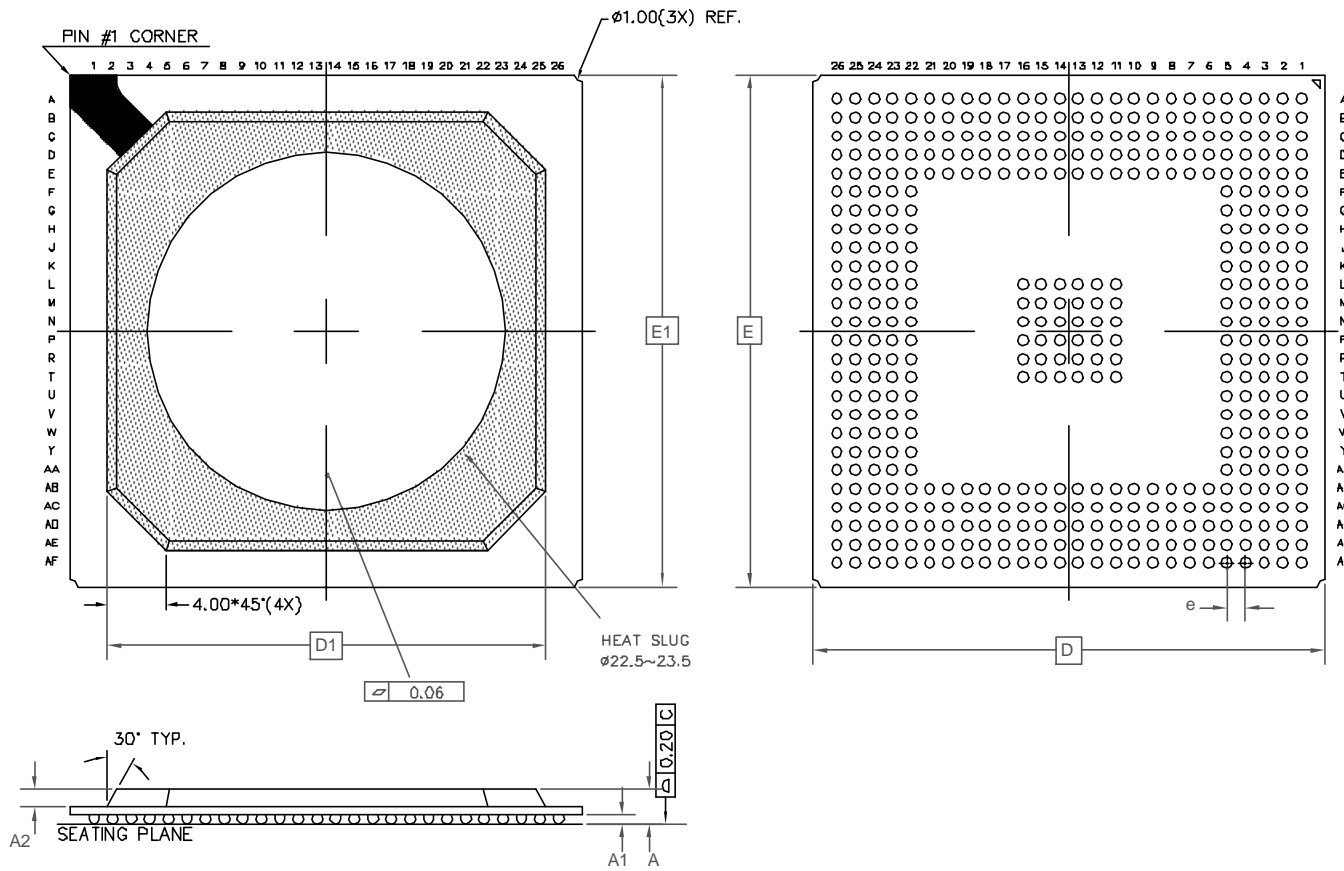

Figure 35 - LED Interface - Output Delay Timing

Symbol	Parameter	Variable Freq.		Note
		Min (ns)	Max (ns)	
LE1	LE_CLKO			Reference Output Clock
LE2	LE-DO Output Valid Delay	-1	7	$C_L = 30\text{pf}$
LE3	LE_SYNC0 Output Valid Delay	-1	7	$C_L = 30\text{pf}$

Table 18 - AC Characteristics - LED Interface



DIMENSION	MIN	MAX
A	2.20	2.46
A1	0.50	0.70
A2	1.17 REF	
D	34.80	35.20
D1	30.00 REF	
E	34.80	35.20
E1	30.00 REF	
b	0.60	0.90
e	1.27	
N	456	
Conforms to JEDEC MS - 034		

1. CONTROLLING DIMENSIONS ARE IN MM
2. DIMENSION "b" IS MEASURED AT THE MAXIMUM SOLDER BALL DIAMETER
3. PRIMARY DATUM -C- AND SEATING PLANE ARE DEFINED BY THE SPHERICAL CROWNS OF THE SOLDER BALLS.
4. N IS THE NUMBER OF SOLDER BALLS
5. NOT TO SCALE.
6. SUBSTRATE THICKNESS IS 0.56 MM

© Zarlink Semiconductor 2003 All rights reserved.					Package Code	GK
ISSUE	1				Previous package codes:	Package Outline for 456 Ball HSBGA (35x35x2.33mm)
ACN	213982				BH / G	
DATE	3Feb03					GPD00826
APPRD.						



**For more information about all Zarlink products
visit our Web Site at
www.zarlink.com**

Information relating to products and services furnished herein by Zarlink Semiconductor Inc. or its subsidiaries (collectively "Zarlink") is believed to be reliable. However, Zarlink assumes no liability for errors that may appear in this publication, or for liability otherwise arising from the application or use of any such information, product or service or for any infringement of patents or other intellectual property rights owned by third parties which may result from such application or use. Neither the supply of such information or purchase of product or service conveys any license, either express or implied, under patents or other intellectual property rights owned by Zarlink or licensed from third parties by Zarlink, whatsoever. Purchasers of products are also hereby notified that the use of product in certain ways or in combination with Zarlink, or non-Zarlink furnished goods or services may infringe patents or other intellectual property rights owned by Zarlink.

This publication is issued to provide information only and (unless agreed by Zarlink in writing) may not be used, applied or reproduced for any purpose nor form part of any order or contract nor to be regarded as a representation relating to the products or services concerned. The products, their specifications, services and other information appearing in this publication are subject to change by Zarlink without notice. No warranty or guarantee express or implied is made regarding the capability, performance or suitability of any product or service. Information concerning possible methods of use is provided as a guide only and does not constitute any guarantee that such methods of use will be satisfactory in a specific piece of equipment. It is the user's responsibility to fully determine the performance and suitability of any equipment using such information and to ensure that any publication or data used is up to date and has not been superseded. Manufacturing does not necessarily include testing of all functions or parameters. These products are not suitable for use in any medical products whose failure to perform may result in significant injury or death to the user. All products and materials are sold and services provided subject to Zarlink's conditions of sale which are available on request.

Purchase of Zarlink's I²C components conveys a licence under the Philips I²C Patent rights to use these components in and I²C System, provided that the system conforms to the I²C Standard Specification as defined by Philips.

Zarlink, ZL and the Zarlink Semiconductor logo are trademarks of Zarlink Semiconductor Inc.

Copyright Zarlink Semiconductor Inc. All Rights Reserved.

TECHNICAL DOCUMENTATION - NOT FOR RESALE
