

MW400S

400 Watts Output Power

ACTIVE POWER FACTOR CORRECTION & ISOLATED DC OUTPUT MODULE



HOW TO ORDER

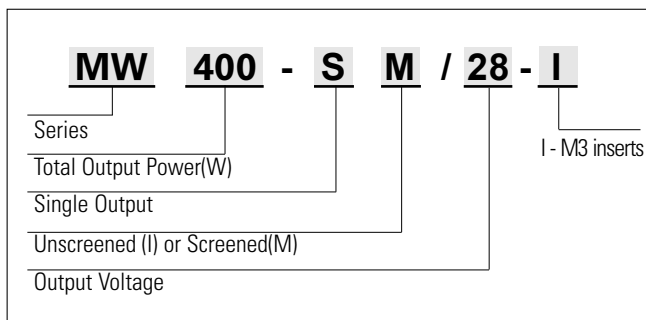

INPUT CHARACTERISTICS

	Min.	Typ.	Max.	Units
Input Voltage (Single Phase)	90		265	Vac
Input Frequency Range	47		440	Hz
Input Voltage DC	120		380	Vdc
Inrush Current				
@115 Vrms			20	A
@240 Vrms			28	A
Input Filter Capacitance		3.1		µF
Power factor @ 400W Output Power				
115V _{in} / 60Hz	0.98	0.99		
115V _{in} / 400Hz	0.94	0.95		
230V _{in} / 50Hz	0.95	0.97		
Efficiency at Full Load				
28Vout, 115V _{in} / 60Hz		81		%
28Vout, 115V _{in} / 400Hz		80		%
28Vout, 230V _{in} / 50Hz		82		%
5Vout, 115V _{in} / 60Hz		78		%
5Vout, 115V _{in} / 400Hz		77		%
5Vout, 230V _{in} / 50Hz		80		%
No Load Input Current		.55		Arms
No Load Input Power		60		W
Input Power, Output Disabled		12		W
Input Undervoltage Shutdown			89	Vac
Input Undervoltage Hysteresis		6		Vac

FEATURES

- Meets Harmonic Requirements of MIL - STD - 1399
- Meets CE101 and CE102 of MIL - STD - 461 (No external filter required)
- Meets all requirements of MIL - STD - 704E
- Non-latching Over Temperature Protection
- Latching Output Overvoltage Protection
- Isolated Input AC Good TTL Signal
- Isolated Output DC Good TTL Signal
- Fully rated 400 Watts of output power from 90 VAC to 265 VAC and up to 100°C baseplate temperature
- Utilizes non isolated boost topology followed by isolated DC-DC converter
- Environmental Screening available
- Fixed frequency PFC and DC-DC converters synchronized at 240/480 kHz or to a 500 - 550 kHz external clock
- 385 VDC Intermediate Bus is accessible at the input connector

SELECTION CHART

Nominal Output Voltage (Volts)	Output Current (Amps)	Model Number (Unscreened)	Model Number (Screened)
2	100	MW400SI/2	MW400SM/2
3.3	100	MW400SI/3.3	MW400SM/3.3
5	80	MW400SI/5	MW400SM/5
12	33.3	MW400SI/12	MW400SM/12
15	26.7	MW400SI/15	MW400SM/15
28	14.3	MW400SI/28	MW400SM/28

All specifications are typical @+25°C with nominal input voltage under full output load conditions, unless otherwise noted. Specifications subject to change without notice.

MW400S Active Power Factor Correction & Isolated Output Module

INTERMEDIATE BUS CHARACTERISTICS

	Min.	Typ.	Max.	Units
Nominal / Voltage	375	385	390	Vdc
Internal Holdup Capacitance		200		μF
External Holdup Capacitance (customer supplied)	0		600	μF
Min. Output Holdup Voltage		190	200	Vdc
Output Holdup Time	20	24		mS

CONTROLS INTERFACE CHARACTERISTICS

Referenced to floating Signal Ground

	Min.	Typ.	Max.	Units
TTL Logic Disable Current		135	150	μA
TTL Logic Disable Voltage	0		0.8	V
Sync Input Voltage	4.5		5.1	Vp-p
Sync Input Frequency	500		550	kHz
Sync Input Duty (High)	15		55	%
Sync Output Voltage		4	5	Vp-p
Status "OK"	4.4		5	V
Status "Bad" @ 2mA	0		0.8	Vdc
AC OK Threshold	88	90	95	Vac
AC "Bad" Response Time		8	10	mS
Output OK Threshold	±5	±7	±9	%Vout
Turn-on Overshoot			150 ¹	mV
Standby 13V	12		15	V
Standby 13V Load	0		15	mA

¹ 150mV or 3% Vout, whichever is greater.

TEMPERATURE CHARACTERISTICS

	Min.	Typ.	Max.	Units
Operating ¹	-40		+100	°C
Storage - Ambient	-55		+105	°C
Over Temperature Shutdown ²		+106	+115	°C

¹ Start-up guaranteed to -55°C

² Measured at baseplate (center line of output connector x center line of baseplate)

OUTPUT CHARACTERISTICS

	Min.	Typ.	Max.	Units	
Set Point Accuracy			50 ¹	mV	
Load Regulation			25/0.5 ²	mV/%	
Line Regulation		5/0.1	20/0.2 ³	mV/%	
Ripple P-P (10 MHz)		60	100/1 ⁴	mV/%	
Overvoltage Protection					
2 - 5 Vout		125/0.7 ⁵		%/Vout	
12 - 28 Vout		125		%/Vout	
Transient Response Time - Overshoot					
20 - 80% Load (@Nom.Line)		200/100	500/250 ⁶	μS/mV	
115 - 180Vac per MIL-STD-704A			500/250 ⁶	μS/mV	
102 - 124Vac per MIL-STD-704A			500/250 ⁶	μS/mV	
92 - 138Vac per MIL-STD-1299			500/250 ⁶	μS/mV	
163 - 281Vac, 50 Hz			500/250 ⁶	μS/mV	
240 - 350Vdc per MIL-STD-704E			500/250 ⁶	μS/mV	
50 - 100% Load (@Nom.Line)		200/100	500/250 ⁶	μS/mV	
Temperature Drift		0.02	0.05	%/°C	
Long Term Drift		0.02	0.05	%/Khrs	
Current Limit		110	125	140	%/Iout
Short Circuit Current		25	50	75	%/Iout
Load Capacitance			200 ⁷	μF	
Remote Sense Compensation			0.5/10 ⁸	Vdc/%	
Trim Range		90		110	%/Vout
Turn On Time		260	300	mS	
Logic Turn On Time		8	10	mS	

¹ or 1% maximum, whichever is greater

² whichever is greater from No Load to Full Load with line constant

³ whichever is greater from Low Line to High Line at Full Load

⁴ whichever is greater measured at 10 MHz Bandwidth

⁵ or 0.7V maximum, whichever is greater

⁶ or 5% maximum, whichever is greater

⁷ or 3X Co, whichever is greater

⁸ lesser of 10% of Vout or 0.5V

ISOLATION CHARACTERISTICS

	Min.	Units
Isolation		
Input to Case	1000	Vdc
Input to Output	1000	Vdc
Input to Signal Ground	1000	Vdc
Output to Case	250	Vdc
Signal Ground to Output to Case	250	Vdc
Insulation Resistance @ 50Vdc	50	Mohm

All specifications are typical @+25°C with nominal input voltage under full output load conditions, unless otherwise noted. Specifications subject to change without notice.

M-GRADE - ENVIRONMENTAL SCREENING

Stabilization Bake	+105°C for 24 hours similar to MIL-STD-883, M1008.2, Condition B
Temperature Cycling	10 cycles at -55°C to +105°C (transition period 5°C/ min) similar to MIL-STD-883, M1010, Condition B
Burn in	150 Hours at 85°C min.
Final Testing	Full ATP
MTBF @ 50°C, GB	144,830 Hours

I-GRADE - ENVIRONMENTAL SCREENING

Burn in	16 Hours @ 50°C min.
Final Testing	Full ATP
MTBF @ 50°C, GB	71,330 Hours

MECHANICAL CHARACTERISTICS

Weight	43.3	oz.
	1230	grams
Size	6.5 x 8.0 x 1.00	inch
	165 x 203 x 25.4	mm
Volume	52.0	inch ³
	852	cm ³
Material		
Case	Steel, 0.024"	
Baseplate	Aluminum Alloy	
Finish		
Case	Nickel Plated	
Baseplate	None	
Mounting		
Standard	6-32 THD Inserts	
Option - I	Metric M4- 0.7 inserts	

CASE DRAWING

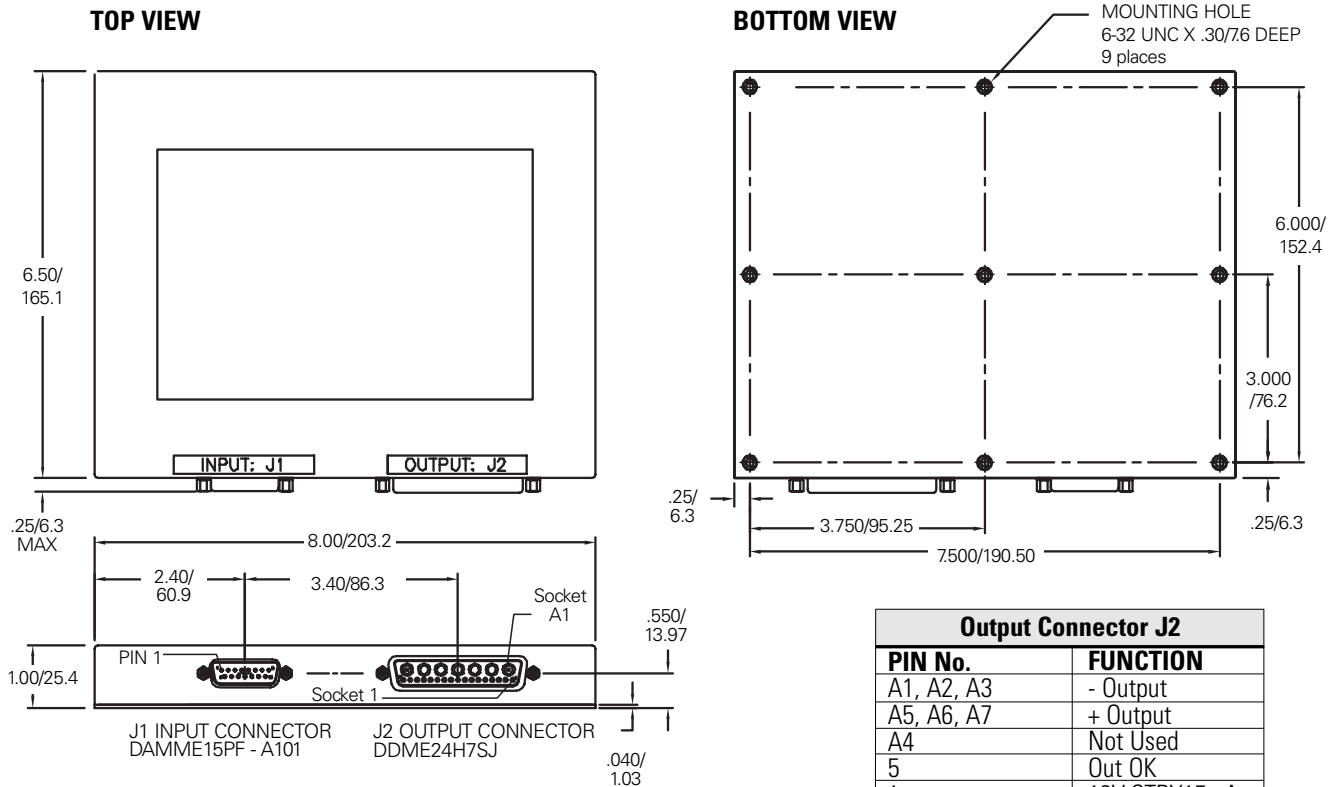

Input Connector J1

PIN No.	FUNCTION
1, 9	AC1
3, 10	AC2
8, 15	Chas Gnd
6	Ext. Cap (+)
5	Ext. Cap (-)
2, 4, 7, 11, 12, 13, 14	Not Used

Output Connector J2

PIN No.	FUNCTION
A1, A2, A3	- Output
A5, A6, A7	+ Output
A4	Not Used
5	Out OK
1	13V STBY15mA
14, 15	Signal Gnd
10	+ Sense
9	- Sense
3	TTL
17	Sync
7	Trim
12	AC OK
2, 4, 6, 8, 11, 13, 16	Not Used

Tolerances: inches - x.xx = ±0.03 mm - x.x = ±0.8
 x.xxx = ±0.015 x.xx = ±0.40

All specifications are typical @+25°C with nominal input voltage under full output load conditions, unless otherwise noted. Specifications subject to change without notice.

MW400S Active Power Factor Correction & Isolated Output Module

PERFORMANCE CHARACTERISTICS

1. Power Factor vs. Input Voltage

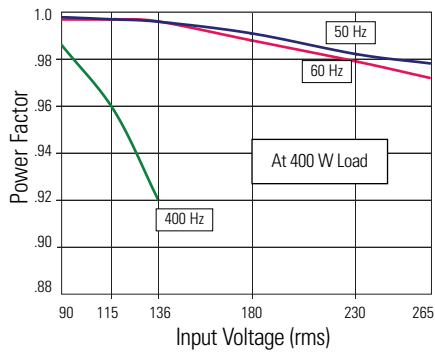

2. Power Factor vs. Output Power

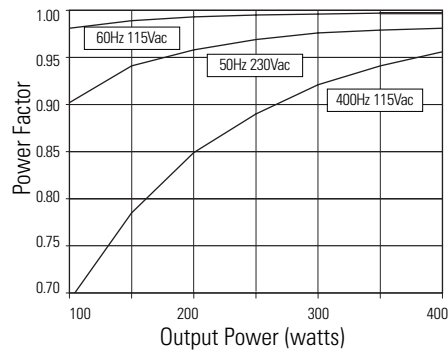

3. Efficiency vs. Input Voltage

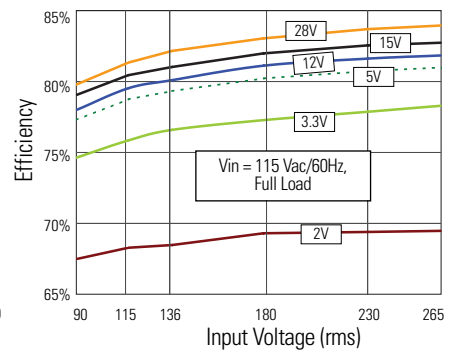

4. Efficiency vs. Output Power

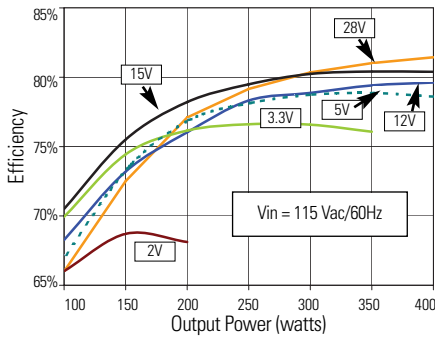

5. AC Input Voltage & Current

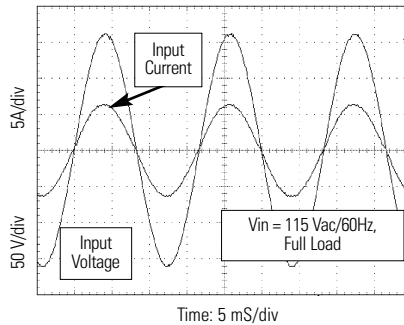

6. Output Ripple (5Vout)

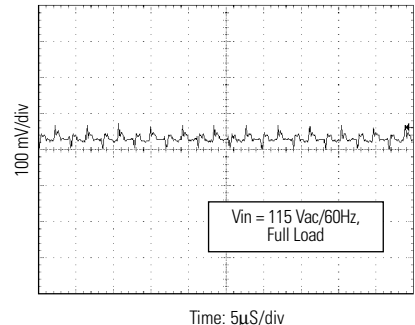

7. Load Transient Response (5Vout)

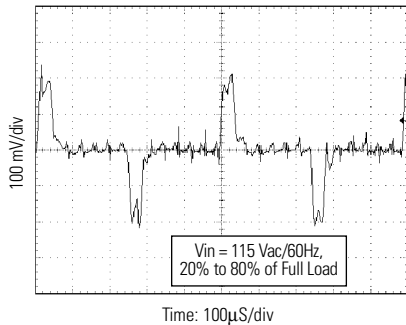

8. Line Transient (60 Hz), no response at output

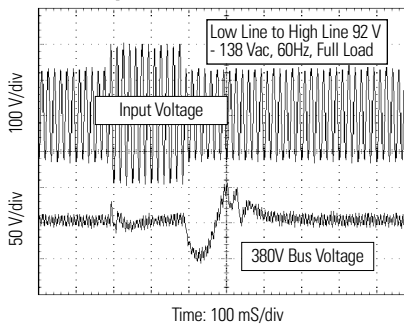

9. Line Transient (400 Hz), no response at output

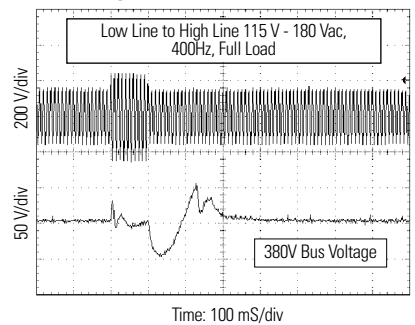

10. Line Transient (50 Hz), no response at output

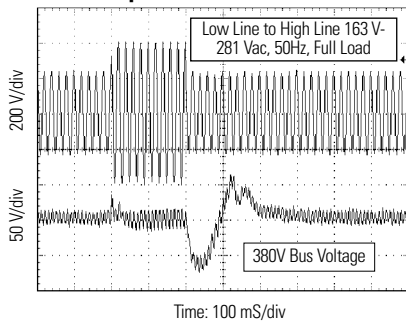

11. Inrush Current vs. Intermediate Bus

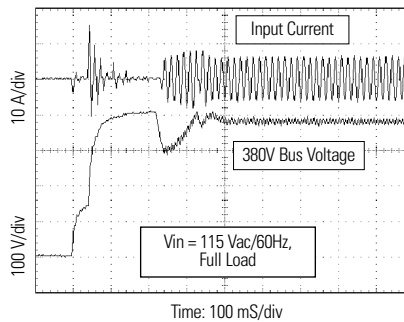

12. Turn-on Input Voltage & Input Current vs. Output Voltage

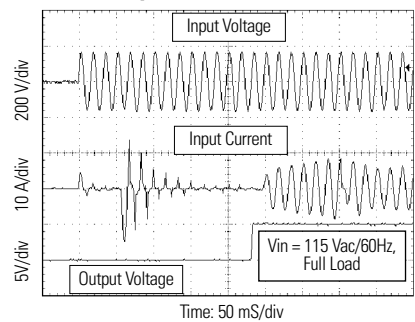

All specifications are typical @+25°C with nominal input voltage under full output load conditions, unless otherwise noted. Specifications subject to change without notice.

MW400S Active Power Factor Correction & Isolated Output Module

PERFORMANCE CHARACTERISTICS

13. Turn-on Input Voltage & Input Current vs. Output Voltage

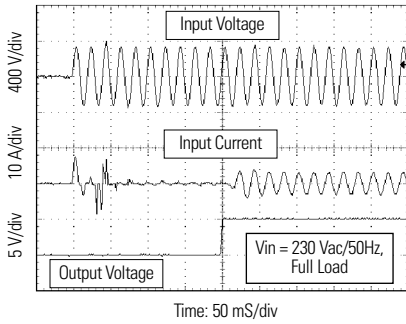

14. TTL Turn-On

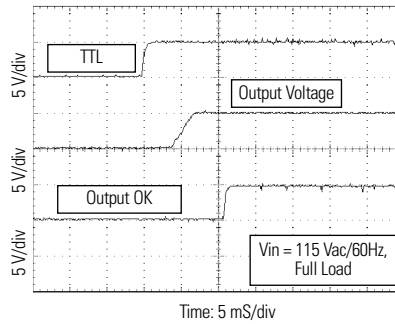

15. TTL Turn-Off

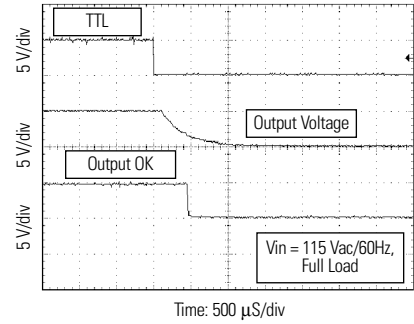

16. Input Voltage Turn-Off vs. Output Voltage

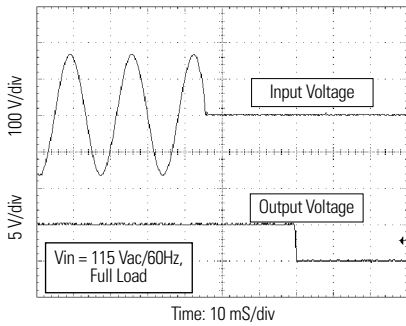

17. Input Voltage Turn-Off vs. AC OK

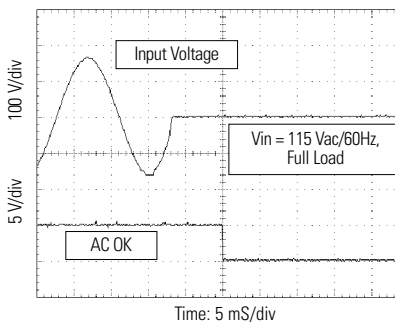

18. Input Voltage Turn-On vs. AC OK

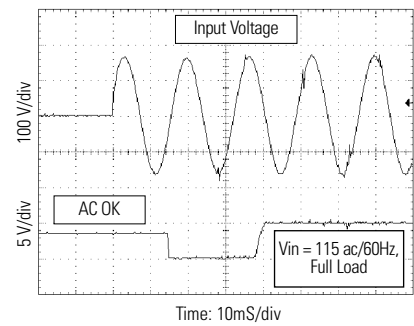

19. Free-running Sync Output

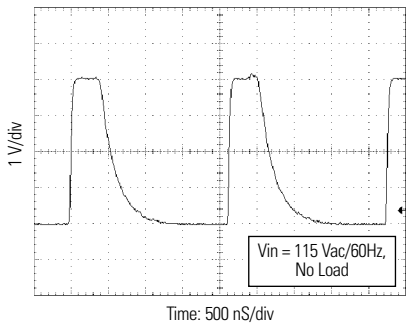

20. Output Converter Voltage Loop Gain & Phase (5Vout)

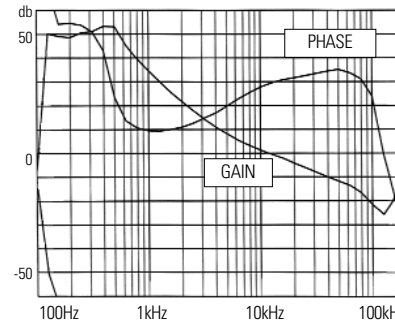

21. Output Converter Voltage Loop Gain & Phase (28Vout)

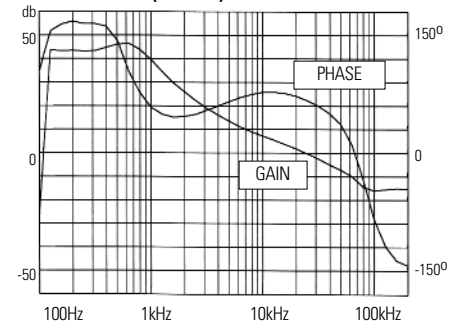

22. MIL-STD-461D CE101-4

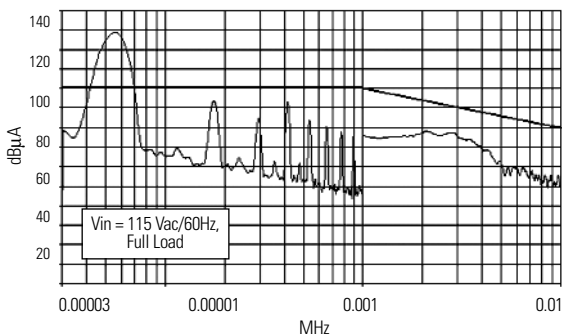

23. MIL-STD-461D CE102-1

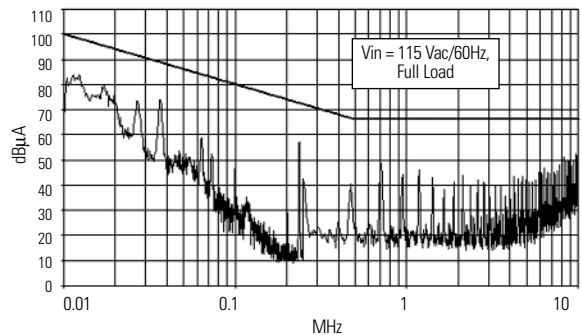

All specifications are typical @+25°C with nominal input voltage under full output load conditions, unless otherwise noted. Specifications subject to change without notice.

MW400S Active Power Factor Correction & Isolated Output Module

BLOCK DIAGRAM OF MW400S

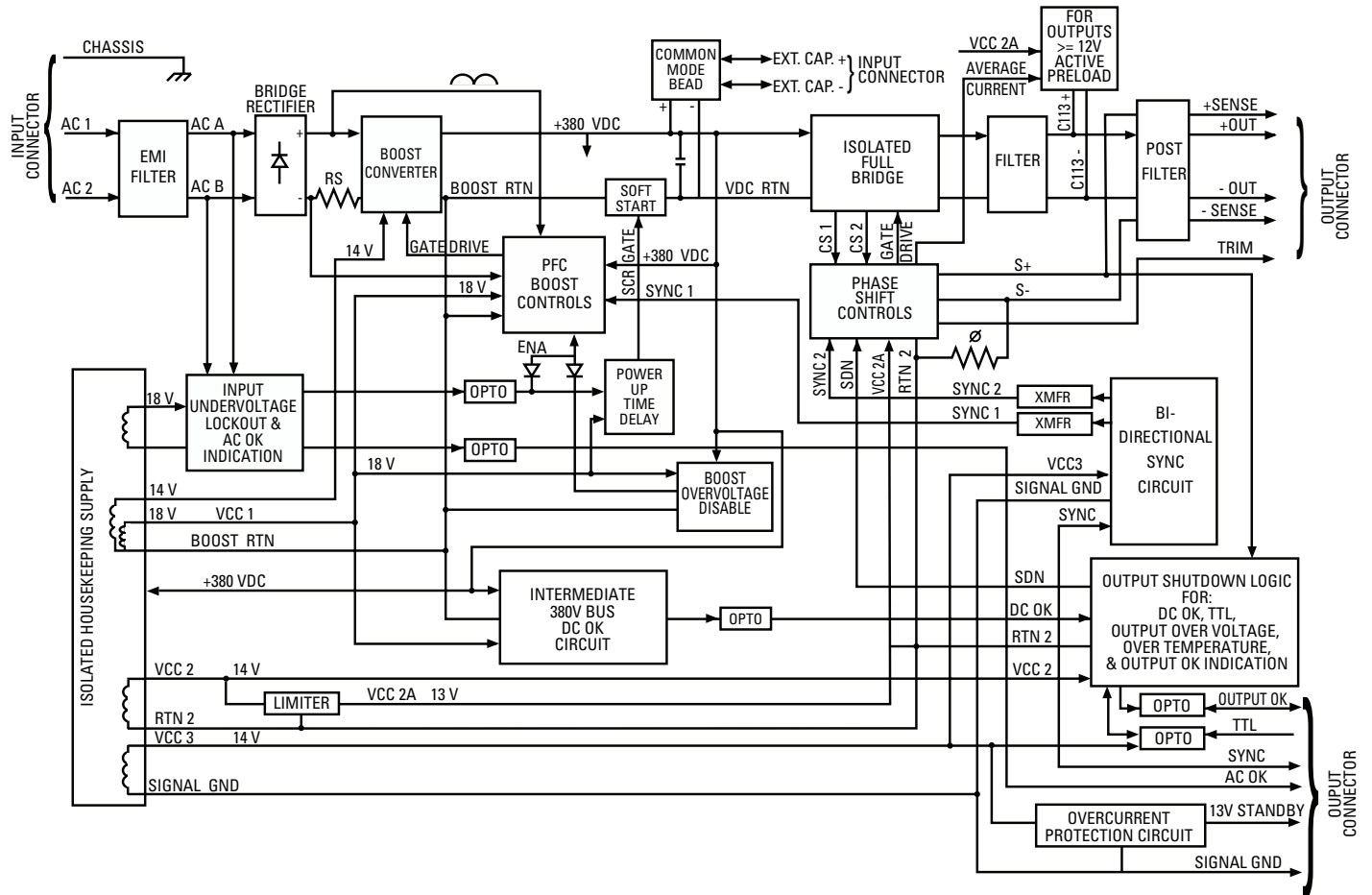

All specifications are typical @+25°C with nominal input voltage under full output load conditions, unless otherwise noted. Specifications subject to change without notice.