

M21250/M21251/M21252

Quad-Channel CDR/Reclocker (42 Mbps - 3.2 Gbps)

The M21250, M21251, and M21252 (M2125x) devices are high-performance quad channel retimers optimized for telecom, datacom, and digital video applications. Each channel of the CDR/reclocker array includes an independent multi-rate CDR/reclocker, allowing maximum flexibility in system design. Signal conditioning features of the M2125x include input equalization and output pre-emphasis to compensate for lossy PCB traces and backplane connectors. A built-in frequency synthesizer allows each channel of the device to operate at a different data rate simultaneously while operating from a single reference clock. The M2125x can be controlled through hardwired pins or via a 2-wire or 4-wire serial programming interface. The serial programming interface allows users to have complete control of the device features. The M2125x devices support JTAG external boundary scan which includes all of the high-speed I/O as well as the digital I/O.

Features

- Four independent CDR/reclockers (CDR/RCLKs) SMPTE, DVB-ASI compliant
- Integrated loop filter and terminations
- Serial control or hardwired control, JTAG boundary scan
- Low power consumption of 400 mW (1 channel active)
- Built-in pattern generator and receiver with JTAG support for module and system testing (PRBS, 8b/10b, Fibre Channel, User Programmable patterns)
- User Selectable Input Equalization and Pre-Emphasis for backplane ISI reduction
- Multirate support (42 Mbps - 3.2 Gbps)
- Differential outputs for recovered clock and retimed data

Applications

- 3G/HD/SD-SDI Routing Switchers
- 3G/HD/SD-SDI Video Transport Systems
- 3G/HD/SD-SDI Distribution Amplifiers
- Backplane Reach Extension
- SONET Systems and Modules
- 10GBASE-CX4 Systems
- Gigabit Ethernet Systems
- SAS/S-ATA/S-ATA2 Systems
- PCI Express

Standards Compliance

- SMPTE 292M
- SMPTE 259M
- SMPTE 344M
- SMPTE 424M

Functional Block Diagram

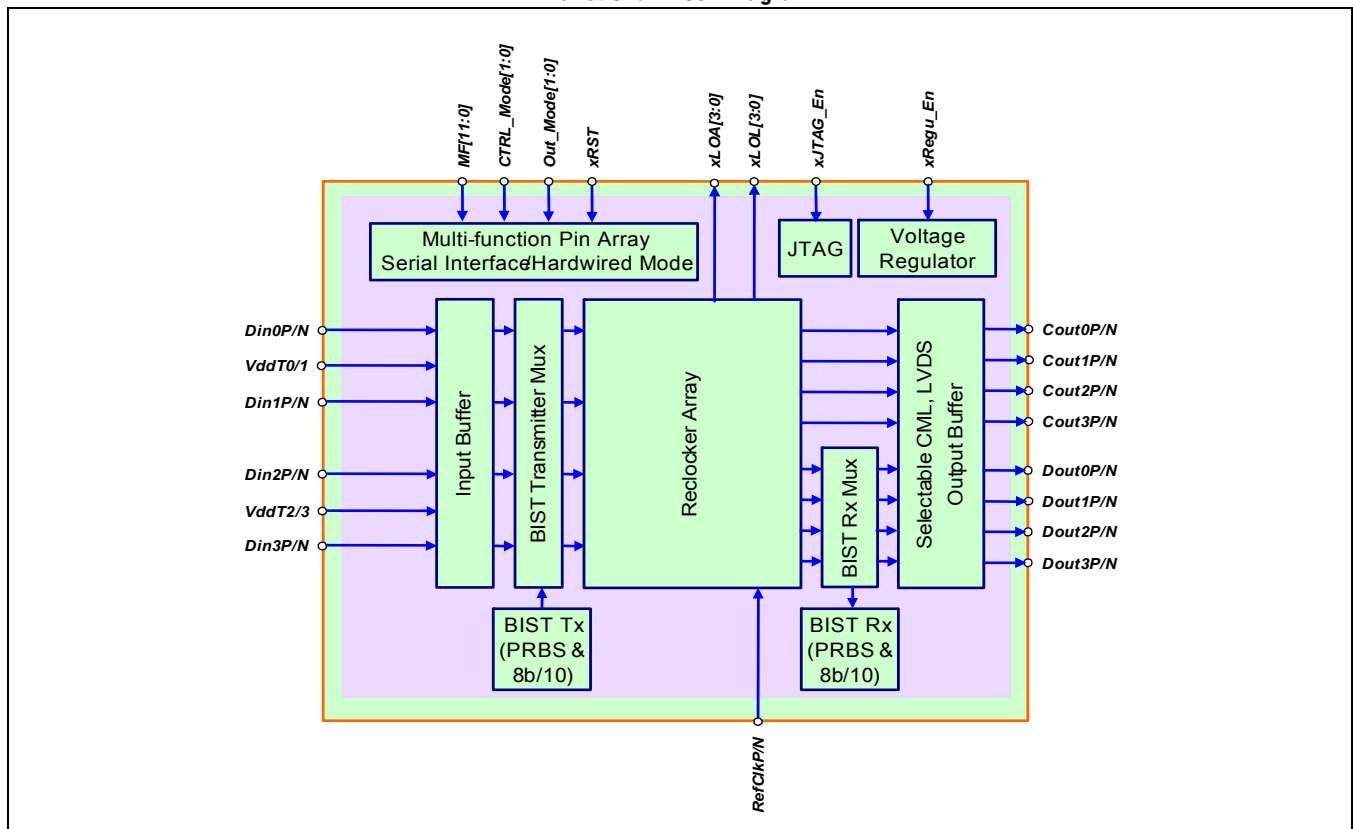

Ordering Information

Part Number	Ordering Part Number	Package
M21250 Quad Multi-rate CDR/Reclocker (42–3200 Mbps)	M21250-12	72-terminal, 10mm, QFN
M21251 Quad Multi-rate CDR/Reclocker (42–1600 Mbps)	DS-M21251-21	72-terminal, 10mm, QFN
M21252 Quad Multi-rate CDR/Reclocker (42–540 Mbps)	DS-M21252-21	72-terminal, 10mm, QFN
M21250 Quad Multi-rate CDR/Reclocker (42–3200 Mbps)	M21250G-12*	72-terminal, 10mm, QFN, RoHS compliant package
M21251 Quad Multi-rate CDR/Reclocker (42–1600 Mbps)	DS-M21251G-21*	72-terminal, 10mm, QFN, RoHS compliant package
M21252 Quad Multi-rate CDR/Reclocker (42–540 Mbps)	DS-M21252G-21*	72-terminal, 10mm, QFN, RoHS compliant package

* The letter “G” designator after the part number indicates that the device is RoHS-compliant. The RoHS-compliant devices are backwards compatible with 225°C reflow profiles.
Refer to www.mindspeed.com for additional information.

Revision History

Revision	Date	Comments
H	March 2009	<ul style="list-style-type: none"> - Added 3G support. - Revised xCS timing in Figure 1-5 and Figure 1-6. - Added SD HD, and 3G parameters to Table 1-12 and Pin 24 default in Table 1-21. - Added Note 4 in Table 2-2. - Revised Bit 5 description in Table 3-33.
G	May 2008	<ul style="list-style-type: none"> - Added SMPTE 424M in standards compliance list. - Revised bit 5:4 description in Table 3-31. - Added additional register details in Section 3.0.
F	June 2006	<ul style="list-style-type: none"> - Added support for Telecom and Datacom applications. - Revised maximum input termination to VddT specification, Table 2-5. - Added clock output differential medium swing specification, Table 2-6. - Reformatted register tables. - Updated ordering part numbers. - Adjusted temperature range to -40°C to +85°C
E	August 2005	<ul style="list-style-type: none"> - Changed ESD rating for HBM testing to 350V. - Included details for operation at data rates above 3.0 Gbps. - References to LVPECL output mode removed. Inputs can be AC-coupled to LVPECL.
D	July 2005	<ul style="list-style-type: none"> - Adjusted temperature range to 0 °C to +70 °C from -40 °C to +85 °C.
C	January 2005	<ul style="list-style-type: none"> - Added RoHS packaging options. - Input sensitivity change from 50 mVpp to 100 mVpp. - Updated ARD description. - Updated device register tables.
B	April 2004	Revision B.
A	October 2003	Original release.



Table of Contents

Ordering Information	ii
Revision History	ii
Table of Contents	iii
List of Figures	vi
List of Tables	vii
1.0 Functional Description	1
1.1 Applications	1
1.2 Detailed Feature Descriptions	4
1.2.1 Conventions	4
1.2.2 Reset	4
1.2.3 Internal Voltage Regulator	4
1.2.4 High-Speed Input/Output Pins	4
1.2.5 CDR/Reclocker Reference Frequency	5
1.2.6 Multifunction Pins Overview	5
1.2.7 Multifunction Pins Defined for Hardwired Mode	6
1.2.8 Multi-function Pins: Four-Wire Serial Interface	7
1.2.9 Two-Wire Serial Interface	9
1.2.10 JTAG	10
1.2.11 Input Deterministic Jitter Attenuators	10
1.2.12 Output Pre-Emphasis	12
1.2.13 CDR/RCLK Overview	12
1.2.14 General CDR/RCLK Features	13
1.2.15 Multi-Rate CDR Data-Rate Selection	14
1.2.16 Frequency Acquisition	14
1.2.17 CDR/Reclocker Data Rate Programming (3G/HD/SD-SDI Video Rates Only)	17
1.2.18 Ambient Temperature Range Limitations	18
1.2.19 Loss of Activity	18
1.2.20 Built-In Self Test (BIST) Overview	19
1.2.21 BIST Test Patterns	19
1.2.22 BIST Receiver (BIST Rx) Operation	20
1.2.23 BIST Transmitter (BIST Tx) Operation	20
1.2.24 Junction Temperature Monitor	20
1.2.25 IC Identification / Revision Code	21
1.3 Pin Definitions	22

2.0	Product Specifications	26
2.1	Absolute Maximum Ratings	26
2.2	Recommended Operating Conditions	27
2.3	Power Dissipation	27
2.4	Input/Output Specifications	29
2.5	High-Speed Performance Specifications	36
2.6	Package Drawings and Surface Mount Assembly Details	40
2.7	PCB High-Speed Design and Layout Guidelines	46
2.8	Auto Rate Detect (ARD) for HD/SD-SDI Digital Video Rates	48
3.0	Registers	49
3.1	Global Control Registers	50
3.1.1	00h:Global Control	50
3.1.2	04h: External Reference Frequency Divider Control (RFD)	50
3.1.3	05h:Master IC Reset	51
3.1.4	06h:IC Electronic Identification	51
3.1.5	07h:IC Revision Code	51
3.1.6	10h:Built In Self-Test (BIST) Receiver Channel Select	51
3.1.7	11h:Built In Self-Test (BIST) Receiver Main Control Register	52
3.1.8	12h:Built In Self-Test (BIST) Receiver Bit Error Counter	52
3.1.9	14h:Built In Self-Test (BIST) Transmitter Channel Select	53
3.1.10	15h:Built In Self-Test (BIST) Transmitter Main Control Register	53
3.1.11	17h:Built In Self-Test (BIST) Transmitter PLL Loss of Lock Register	54
3.1.12	18h:Built In Self-Test (BIST) Transmitter PLL Control Register A	55
3.1.13	19h:Built In Self-Test (BIST) Transmitter PLL Control Register B	56
3.1.14	1Ah:Built In Self-Test (BIST) Transmitter PLL Control Register C	56
3.1.15	1Bh:Built In Self-Test (BIST) Transmitter 20 bit User Programmable Pattern	56
3.1.16	1Ch:Built In Self-Test (BIST) Transmitter 16/20 bit User Programmable Pattern	57
3.1.17	1Dh:Built In Self-Test (BIST) Transmitter 16/20 bit User Programmable Pattern	57
3.1.18	1Fh:Built In Self-Test (BIST) Transmitter Alarm	57
3.1.19	20h:Internal Junction Temperature Monitor	58
3.1.20	21h:Internal Junction Temperature Value	58
3.1.21	30h:CDR/RCLK Loss of Lock Register Alarm Status	59
3.1.22	31h:Loss of Activity Register Alarm Status	59
3.1.23	32h:VCO Trim Alarm Window	59
3.2	Individual Channel/CDR/RCLK Control	60
3.2.1	M0h:CDR N Control Register A	60
3.2.2	M1h:CDR/RCLK N Control Register B	61
3.2.3	M2h:CDR/RCLK N Control Register C	61
3.2.4	M3h:Output Buffer Control for CDR/RCLK N	62
3.2.5	M4h:Output Buffer Pre-Emphasis Control for Output N	63
3.2.6	M5h:Input Equalization Control for Output N	63
3.2.7	M6h:CDR/RCLK N Loop Bandwidth and Data Sampling Point Adjust	64
3.2.8	M9h:CDR/RCLK N LOL Window Control	64
3.2.9	MAh: Jitter Reduction Control	66

4.0 Appendices 67

 4.1 Glossary of Terms/Acronyms67

 4.2 Reference Documents 67

 4.2.1 External67

 4.2.2 Mindspeed 68



List of Figures

Figure 1-1.	Module Application	1
Figure 1-2.	Backplane Application	2
Figure 1-3.	Recommended Data and Reference Clock Input Coupling Circuitry	3
Figure 1-4.	Serial Word Format	7
Figure 1-5.	Serial WRITE Mode	8
Figure 1-6.	Serial READ Mode	8
Figure 1-7.	STS-48 waveform after transmission through 76" of PCB traces (input to M21250)	11
Figure 1-8.	STS-48 waveform at M21250 output with input shown in Figure 1-7	11
Figure 1-9.	Definition of Pre-Emphasis Levels	12
Figure 1-10.	Block Diagram of Frequency Acquisition Circuits	15
Figure 1-11.	M2125x Pinout Diagram (Top View)	25
Figure 2-1.	Data Input Internal Circuitry	30
Figure 2-2.	Definitions of Eye Parameters	32
Figure 2-3.	Reference Clock Input Internal Circuitry	34
Figure 2-4.	Clock and Data Output Skew Timing	36
Figure 2-5.	SMPTE Jitter Tolerance Specification Mask	37
Figure 2-6.	SONET Jitter Tolerance Specification Mask	37
Figure 2-7.	SONET/SMPTE Jitter Transfer Specification Mask	38
Figure 2-8.	Cross-Section of QFN Package	40
Figure 2-9.	Package Drawing (1 of 2)	41
Figure 2-10.	Package Drawing (2 of 2)	42
Figure 2-11.	72-Pin Package Dimensions	43
Figure 2-12.	PCB Footprint for 72-Pin 10 mm QFN Package	44
Figure 2-13.	PCB Pad Extensions	45
Figure 2-14.	Recommended Via Array for Thermal Pad	45
Figure 2-15.	Trace-Length Matching Using Serpentine Pattern	47
Figure 2-16.	Loop Length Matching for Differential Traces	47



List of Tables

Table 1-1.	Output Interface and Level Mapping (For both hardwired and software modes)	5
Table 1-2.	Output Interface and Recommended AVdd_I/O Range	5
Table 1-3.	Mode Select Pins	6
Table 1-4.	Multifunction Pins for Hardwired Mode	6
Table 1-5.	Hardwired Bit Rates and Associated Reference Frequencies	7
Table 1-6.	Multi-function Pins for Four-Wire Interface	7
Table 1-7.	Serial Interface Timing – Specified at Recommended Operating Conditions	9
Table 1-8.	Multifunction Pins for Two-Wire Interface	9
Table 1-9.	Multifunction Pins for JTAG	10
Table 1-10.	Valid Input Data Ranges	14
Table 1-11.	Reference Clock Frequency Ranges	15
Table 1-12.	DRD/RFD/VCD Settings for Different Data-Rates and Reference Frequencies	16
Table 1-13.	LOL Window Size and Decision Time Examples	17
Table 1-14.	Supported Ambient Temperature Range by Data-Rate	18
Table 1-15.	BIST PRBS Patterns	19
Table 1-16.	BIST 8b/10b Patterns	19
Table 1-17.	Junction Temperature Monitor	21
Table 1-18.	IC Identification/Revision Code Details	21
Table 1-19.	Power Pins	22
Table 1-20.	High-Speed Signal Pins	23
Table 1-21.	Control, Interface, and Alarm Pins	24
Table 2-1.	Absolute Maximum Ratings	26
Table 2-2.	Recommended Operating Conditions	27
Table 2-3.	DC Power Electrical Specifications	27
Table 2-4.	Serial Interface (2-Wire and 4-Wire) CMOS I/O Electrical Specifications	29
Table 2-5.	Input Electrical Specifications	29
Table 2-6.	PCML (Positive Current Mode Logic) Output Electrical Specifications	30
Table 2-7.	LVDS (Low Voltage Differential Signal) Output Electrical Specifications	31
Table 2-8.	Input Equalization Performance Specifications	32
Table 2-9.	Output Pre-Emphasis Performance Specifications	33
Table 2-10.	Reference Clock Input	33
Table 2-11.	CDR/RCLK High-Speed Performance	34

Table 2-12.	SMPTE Jitter Tolerance Mask	37
Table 2-13.	Loop Bandwidths for Typical Video Data Rates*	38
Table 2-14.	CDR/RCLK Alarm Performance	39
Table 3-1.	Register Table Summary	49
Table 3-2.	Global Control (Globctrl: Address 00h)	50
Table 3-3.	External Reference Frequency Divider Control (RFD) (Refclk_ctrl: Address 04h)	50
Table 3-4.	Master IC Reset (Mastreset: Address 05h)	51
Table 3-5.	IC Electronic ID (Chipcode: Address 06h)	51
Table 3-6.	IC Revision Code (Revcode: Address 07h)	51
Table 3-7.	Built In Self-Test (BIST) Receiver Channel Select (BISTrx_chsel: Address 10h)	51
Table 3-8.	Built In Self-Test (BIST) Receiver Main Control Register (BISTrx_ctrl: Address 11h)	52
Table 3-9.	Built In Self-Test (BIST) Receiver Bit Error Counter (BISTrx_error: Address 12h)	52
Table 3-10.	Built In Self-Test (BIST) Transmitter Channel Select (BISTtx_chsel: Address 14h)	53
Table 3-11.	Built In Self-Test (BIST) Transmitter Main Control Register (BISTtx_ctrl: Address 15h)	53
Table 3-12.	Built In Self-Test (BIST) Transmitter PLL Loss of Lock Register (BISTtx_LOLctrl: Address 17h)	54
Table 3-13.	Built In Self-Test (BIST) Transmitter PLL Control Register A (BISTtx_PLL_ctrlA: Address 18h)	55
Table 3-14.	Built In Self-Test (BIST) Transmitter PLL Control Register B (BISTtx_PLL_ctrlB: Address 19h)	56
Table 3-15.	Built In Self-Test (BIST) Transmitter PLL Control Register C (BISTtx_PLL_ctrlC: Address 1Ah)	56
Table 3-16.	Built In Self-Test (BIST) Transmitter 20 bit User Programmable Pattern (BIST_pattern0: Address 1Bh)	56
Table 3-17.	Built In Self-Test (BIST) Transmitter 16/20 bit User Programmable Pattern (BIST_pattern1: Address 1Ch)	57
Table 3-18.	Built In Self-Test (BIST) Transmitter 16/20 bit User Programmable Pattern (BIST_pattern2: Address 1Dh)	57
Table 3-19.	Built In Self-Test (BIST) Transmitter Alarm (BISTtx_alarm: Address 1Fh)	57
Table 3-20.	Internal Junction Temperature Monitor (Temp_mon: Address 20h)	58
Table 3-21.	Internal Junction Temperature Value (Temp_value: Address 21h)	58
Table 3-22.	CDR/RCLK Loss of Lock Register Alarm Status (Alarm_LOL: Address 30h)	59
Table 3-23.	Loss of Activity Register Alarm Status (Alarm_LOA: Address 31h)	59
Table 3-24.	VCO Trim Alarm Window Trim (Alarm_trim: Address 32h)	59
Table 3-25.	CDR N Control Register A (RCLK_ctrlA_N: Address M0h)	60
Table 3-26.	CDR N Control Register B (RCLK_ctrlB_N: Address M1h)	61
Table 3-27.	CDR/RCLK N Control Register C (RCLK_ctrlC_N: Address M2h)	61
Table 3-28.	Output Buffer Control for CDR/RCLK N (Out_ctrl_N: Address M3h)	62
Table 3-29.	Output Buffer Pre-Emphasis Control for Output N (Preemp_ctrl_N: Address M4h)	63
Table 3-30.	Input Equalization Control for Output N (Ineq_ctrl_N: Address M5h)	63
Table 3-31.	CDR/RCLK N Loop Bandwidth and Data Sampling Point Adjust (Phadj_ctrl_N: Address M6h)	64
Table 3-32.	CDR/RCLK N LOL Window Control (LOL_ctrl_N: Address M9h)	64
Table 3-33.	Jitter Reduction Control (Jitter_reduc_N: Address MAh)	66
Table 4-1.	Acronyms	67



1.0 Functional Description

1.1 Applications

- 3G/HD/SD-SDI Routing Switchers
- 3G/HD/SD-SDI Video Transport Systems
- 3G/HD/SD-SDI Distribution Amplifiers
- Backplane Reach Extension
- SONET Systems and Modules
- 10GBASE-CX4 Systems
- Gigabit Ethernet Systems
- SAS/SATA Systems

Figure 1-1. Module Application

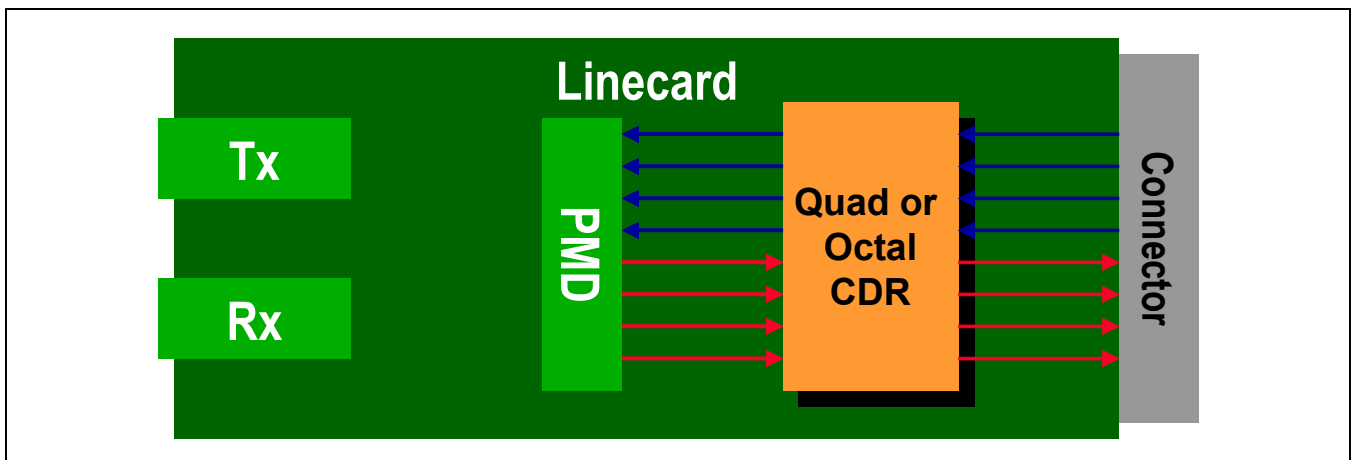

Figure 1-2. Backplane Application

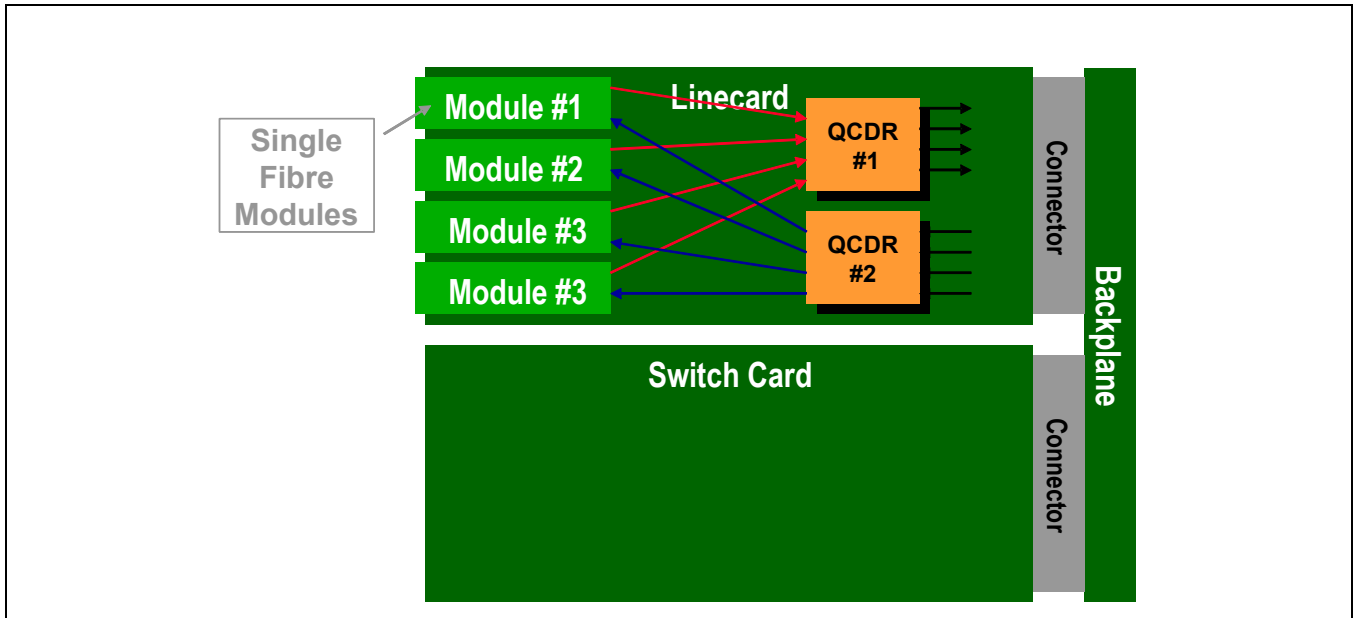
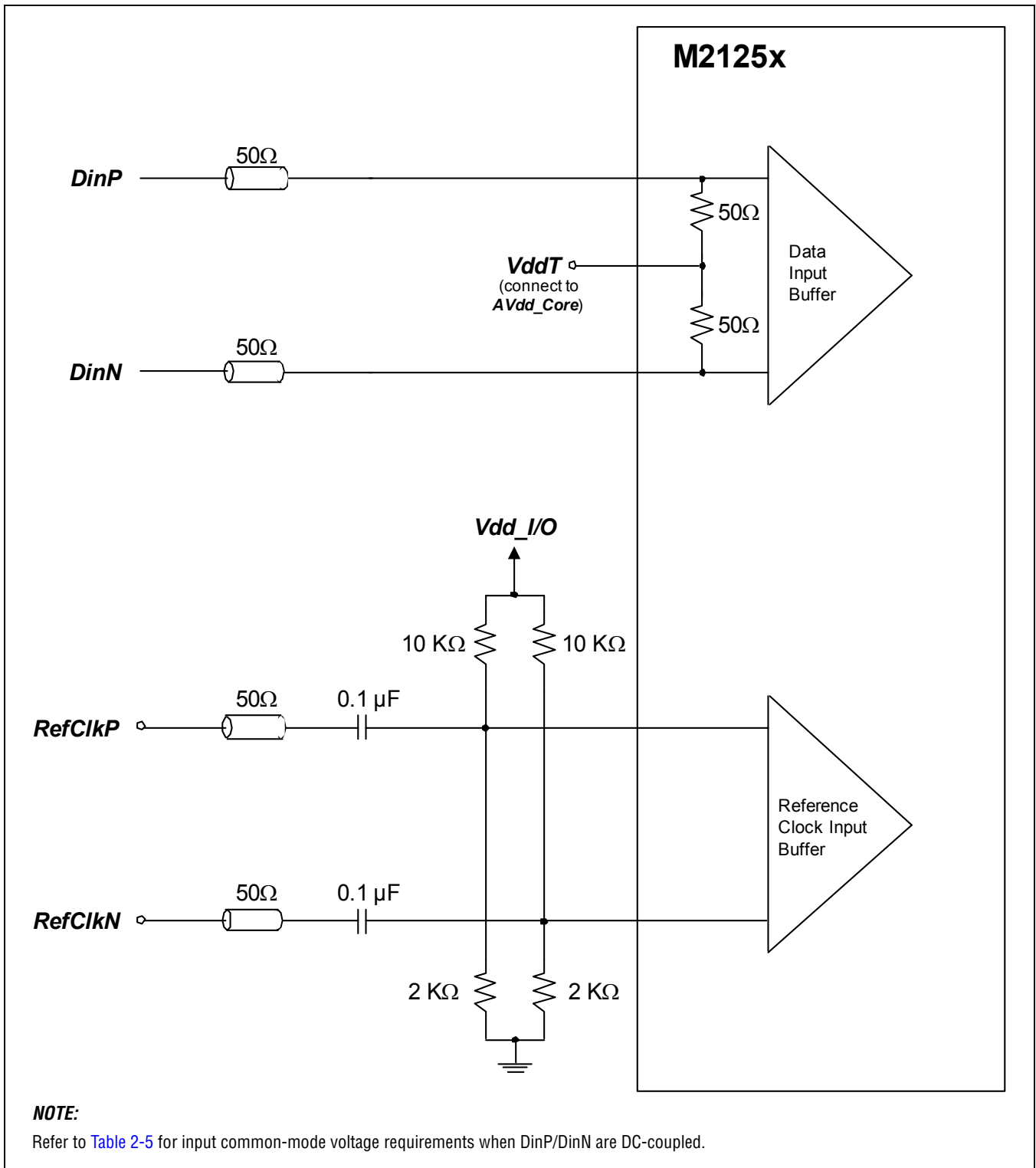

Figure 1-3. Recommended Data and Reference Clock Input Coupling Circuitry



1.2 Detailed Feature Descriptions

1.2.1 Conventions

Throughout this data sheet, physical pins will be denoted in **bold italic** print. An array of pins can be called by each individual pin name (e.g. ***MF0***, ***MF1***, ***MF2***, ***MF3***, and ***MF6***) or as an array (e.g. ***MF*** [6, 3:0]). The M2125x control is accessed through registers that employ an 8-bit address and an 8-bit data scheme. Registers are denoted in italic print, (e.g. *TestRegister*) and individual bits within the register will be called out as *TestRegister* [4:3] to denote the 4th and 3rd bit where bit 0 is the LSB and bit 7 is the MSB. Many features of the device are bit mapped within a register; if the status of the other bits are uncertain, it is recommended that the user reads the value from the register before writing, to assure only the desired bits change. Writing in the same value to the bits within a register does not cause glitches to the unchanged features. The addresses for the registers as well as their functions can be found in detail in [Chapter 3.0](#). The purpose of the text description is to highlight the features of the registers. For redundant items, such as the channel number, the registers will have a nomenclature of *TestReg_0* for channel 0, *TestReg_1* for channel 1, *TestReg_2* for channel 2, *TestReg_3* for channel 3. For general reference, the text will denote such registers as *TestReg_N* where N can vary from 0 to 3. Individual CDR/RCLK circuits are mapped to output channels.

1.2.2 Reset

Upon application of power, the M2125x automatically generates a master reset. At any time, forcing ***xRST*** = L causes the M2125x to enter the master reset state. A master reset can also be initiated by writing AAh to *Mastreset*. Once a master reset is initiated, all registers are returned to the default values, the internal state machines cleared, and all CDR/RCLK/BIST reset to the out-of-lock condition. After a reset, the register *Mastreset* will automatically return to the default value of 00h.

Each individual CDR/RCLK can be soft reset by setting *RCLK_ctrlA_N* [7] = 1 where N = 0 for CDR/RCLK 0, N = 1 for CDR/RCLK 1 and so on. The bit should be returned to 0b for normal operation. After a soft reset, the registers that determine the CDR/RCLK operation options such as data-rate, window sizes, etc., remain unchanged and only the CDR/RCLK state-machine is reset, resulting in an out-of lock condition and a new frequency acquisition is initiated.

1.2.3 Internal Voltage Regulator

The digital and analog core are designed to run at 1.2V, however, for operation from 1.8V to 3.3V, an internal linear regulator is provided. ***xRegu_En*** = L enables the voltage regulator which uses ***AVdd_I/O*** and ***DVdd_I/O*** to generate the required 1.2V for ***AVdd_Core*** and ***DVdd_Core***. In this mode, the ***AVdd_Core*** and ***DVdd_Core*** pins should be connected to a floating DC low inductance PCB plane and AC bypassed to ***Vss*** using standard decoupling techniques. If desired, ***AVdd_Core*** and ***DVdd_Core*** can be separated into individual planes. If 1.2V is available, it can be connected directly to ***AVdd_Core*** and ***DVdd_Core***, to save power, by bypassing the internal linear regulator with ***xRegu_En*** = H. In this case, it is recommended that the ***AVdd_Core*** and ***DVdd_Core*** pins be tied together to a common PCB plane, and bypassed to ***Vss*** with standard decoupling techniques.

1.2.4 High-Speed Input/Output Pins

The high-speed input data interface is a differential input buffer, similar to a PCML design that is referenced to ***AVdd_Core*** (1.2V). The high-speed serial differential data enters the device via ***Din*** [3:0, P/N]. Inputs 0 and 1 are internally terminated with 50Ω to ***VddT0/1*** and inputs 2 and 3 are terminated with 50Ω to ***VddT2/3***. The ***VddT*** pins should be connected to ***AVdd_Core*** for a proper termination of the inputs. Inputs can be AC-coupled to LVPECL, LVDS, and PCML.

The M2125x supports multiple high-speed output modes. The output modes are selectable with hardwired pins only. The I/O interface is set with **Out_Mode** [1:0] and the output level with **MF** [9:8] as shown in Table 1-1. In the serial interface mode, the **Out_ctrl_N** [7:6] register is used to set the data level, and **Out_Mode** [1:0] is used to set the interface type. In the serial interface mode, the data output can be enabled with **Out_ctrl_N** [2] = 1b (default) and the output data polarity can be flipped by setting **Out_ctrl_N** [3] = 1b (default: no inversion). Output data polarity flip is an internal function that would have the same effect as switching the P and N terminals. The recommended **AVdd_I/O** for the different output interfaces is shown in Table 1-2. The PCML+ mode is provided for higher output swings when desired. Operation with **Out_Mode** [1:0] = 10 is not supported.

Table 1-1. Output Interface and Level Mapping (For both hardwired and software modes)

Multifunction Pins & Register MF [9:8] Out_ctrl_N [7:6]	PCML Mode Out_Mode [1:0] = 00b	LVDS Mode Out_Mode [1:0] = 01b	PCML+ Mode Out_Mode [1:0] = 11b
00b	Off	Off	Off
01b	550 mV	RRL at 450 mV	900 mV
10b	900 mV	GPL at 650 mV	1200 mV
11b	1200 mV	1000 mV	1500 mV

Table 1-2. Output Interface and Recommended AVdd_I/O Range

Output Logic	AVdd_I/O Range (V)
Off	1.8 - 3.3
PCML at 550 mV	1.8 - 3.3
PCML at 900 mV	1.8 - 3.3
PCML at 1200 mV	1.8 - 3.3
PCML+ at 1500 mV	1.8 - 3.3
LVDS GPL	1.8 - 3.3
LVDS RRL	1.8 - 3.3

1.2.5 CDR/Reclocker Reference Frequency

The CDR/RCLK requires the use of an external reference clock. An external reference clock is applied to **RefClk**[P/N] to enable frequency acquisition in the CDR/reclocker. PCML and CMOS are examples of the wide variety of interfaces supported for the reference clock. The inputs contain a DC-coupled 100Ω differential termination between **RefClkP** and **RefClkN** along with a 100 KΩ pull-down on each terminal to **Vss**. After this termination/pull-down block, the inputs are AC coupled internally. The common-mode and allowable voltage swings are specified in Table 2-10. The **RefClk** common-mode must be above 250 mV, which may require external pull-ups in the case of external AC coupling.

1.2.6 Multifunction Pins Overview

The M2125x is designed to be an extremely versatile device, with many user selectable options in the CDR/RCLK and I/O, to optimize performance. All of these options can be accessed and controlled through the serial interface. The serial interface I/O pins and address pins are mapped to the multifunction pins **MF** [11:0]. A subset of the key features for most applications, such as standard data-rates, I/O levels, etc., can be selected through **MF** [11:0] in the hardwired mode.

For digital video applications, the hardwired mode does not require the use of the serial interface. In this mode, upon power up (auto reset on power up), the M2125x function is determined by the status of the hardwired pins. Another feature of the multifunction pins is to support JTAG testing of this device during PCB manufacturing.

The various control and test modes of this device are selected with three pins: **CTRL_Mode** [1:0], and **xJTAG_En**. **xJTAG_En** = L overrides **CTRL_Mode** [1:0], and puts the device in JTAG test mode, while **xJTAG_En** = H allows **CTRL_Mode** [1:0] to determine the M2125x control mode, as summarized in [Table 1-3](#).

Table 1-3. Mode Select Pins

Pin	JTAG Test Mode	Hardwired Mode	MSPD 4-Wire Serial	2-Wire Serial
xJTAG_En	L	H	H	H
CTRL_Mode [1:0]	no impact	11b	00b	01b

1.2.7 Multifunction Pins Defined for Hardwired Mode

In the hardwired mode, a subset of options in the M2125x can be accessed with hardwired physical pins, as defined in [Table 1-4](#). The hardwired bit rates are shown in [Table 1-5](#).

Table 1-4. Multifunction Pins for Hardwired Mode

Pin	Name	Function	Description
MF0	Rate_Sel_0	Data-rate selection	CDR/reclocker data-rate select (see Table 1-5 for description)
MF1	Rate_Sel_1	Data-rate selection	CDR/reclocker data-rate select (see Table 1-5 for description)
MF2	Rate_Sel_2	Data-rate selection	CDR/reclocker data-rate select (see Table 1-5 for description)
MF3	Rate_Sel_3	Data-rate selection	CDR/reclocker data-rate select (see Table 1-5 for description)
MF4	xPre_Emp_En	Pre-emphasis control	L = Pre-emphasis enable H = Pre-emphasis disable (floating default)
MF5	xClk_En	Clock Output Enable	L = All clock outputs enabled at same level as data H = All clock outputs off (floating default)
MF6	xClk_Flip_En	Clock Polarity Flip	L = Clock polarity flip H = Standard clock polarity (floating default)
MF7	xPol_Flip_En	Data polarity flip	L = Data polarity flip H = Standard data polarity (floating default)
MF8	Out_Level_[1:0]	Output level selection	00b: All outputs disabled 01b: 550 mV (CML) 10b: 900 mV (CML) 11b: 1200 mV (CML) (floating default) See Table 1-1 for the other output interface modes.
MF9			
MF10	xEQ_En	Equalization control	L = Input equalization enabled H = Input equalization disabled (floating default)
MF11	xRCLK_BYP_En	CDR/RCLK bypass control	L = All CDR/reclockers bypassed and powered down H = All CDR/reclockers enabled (floating default)

Table 1-5. Hardwired Bit Rates and Associated Reference Frequencies

Pins MF [3:0]	Application	Bit Rate (Mbps)	Reference Frequency (MHz)
0000	3G-SDI	2967 /2970	12.0
0001	HD-SDI	1485 /1483.5	12.0
0010	2 x SD-SDI	540	12.0
0011	Progressive Scan Video	360	12.0
0100	SD-SDI	270	12.0
0101	Legacy Comp Video	177	12.0
0110	Legacy Comp Video	143	12.0

1.2.8 Multi-function Pins: Four-Wire Serial Interface

The four-wire serial programming interface has been used on Mindspeed earlier generation crosspoints and CDRs and is capable of higher speed operation than the two-wire serial interface. The interface consists of a uni-directional clock and a data input and data output line. For use with multiple ICs, a serial interface chip select pin is provided. Table 1-6 illustrates how the four-wire serial interface maps into the multi-function pins. This serial interface can operate with a maximum clock rate of 70 MHz.

Table 1-6. Multi-function Pins for Four-Wire Interface

Pin	Function	Description
MF4	SDI	Serial Data In
MF5	xCS	Chip Select, active low
MF10	SCLK	Clock
MF11	SDO	Serial Data Out

The serial I/O shifts data in from the external controller on the rising edge of **SCLK**. The serial I/O operation is gated by **xCS**. Data is shifted in on **SDI** on the falling edge of **SCLK**, and shifted out on **SDO** on the rising edge of **SCLK**. To address a register, a 10-bit input consists of the first bit (Start Bit, SB = 1), the second bit (Operation Bit, OP = 1 for read, = 0 for write), followed by the 8-bit ADDR (MSB first) as shown in Figure 1-4.

Figure 1-4. Serial Word Format

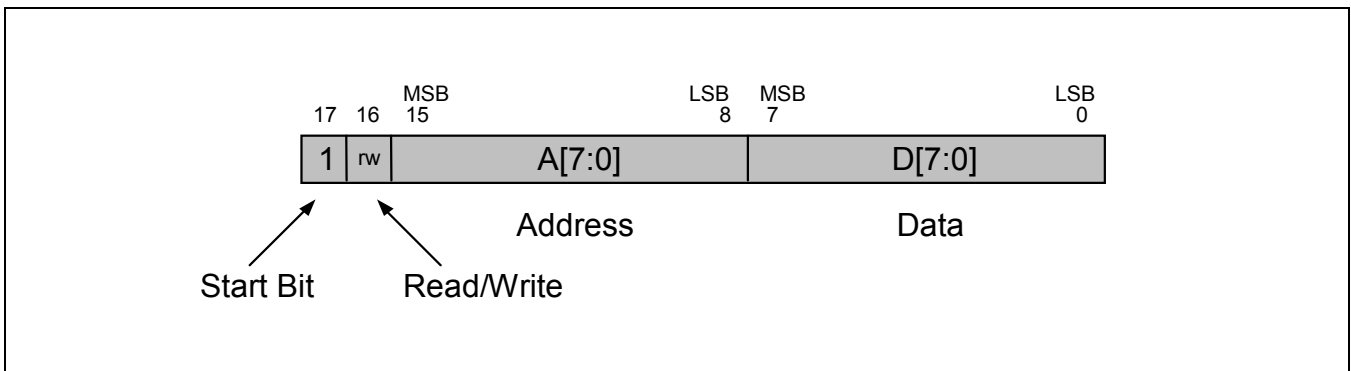

Figure 1-5 illustrates the Serial Write Mode. To initiate a Write sequence, **xCS** goes low before the falling edge of **SCLK**. On each falling edge of the clock, the 18-bits consisting of the SB = 1, OP = 0, ADDR, and DATA, are latched into the input shift register. The rising edge of **xCS** must occur before the falling edge of **SCLK** for the last bit. Upon receipt of the last bit, one additional cycle of **SCLK** is necessary before DATA transfers from the input shift register to the addressed register. If consecutive read/write cycles are being performed, it is not necessary to insert an extra clock cycle between read/write cycles, however one extra clock cycle is needed after the last data bit of the last read/write cycle.

Figure 1-5. Serial WRITE Mode

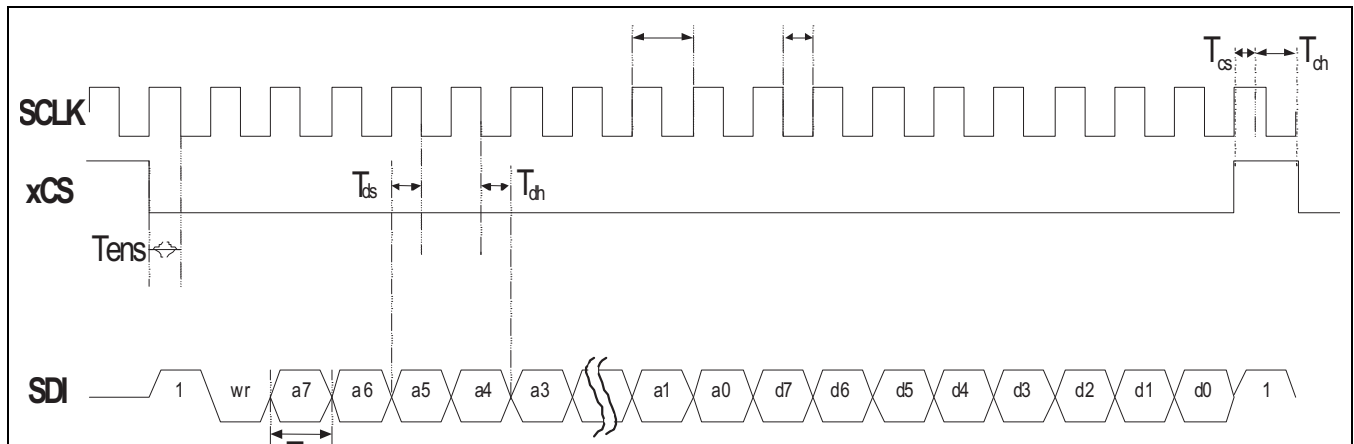
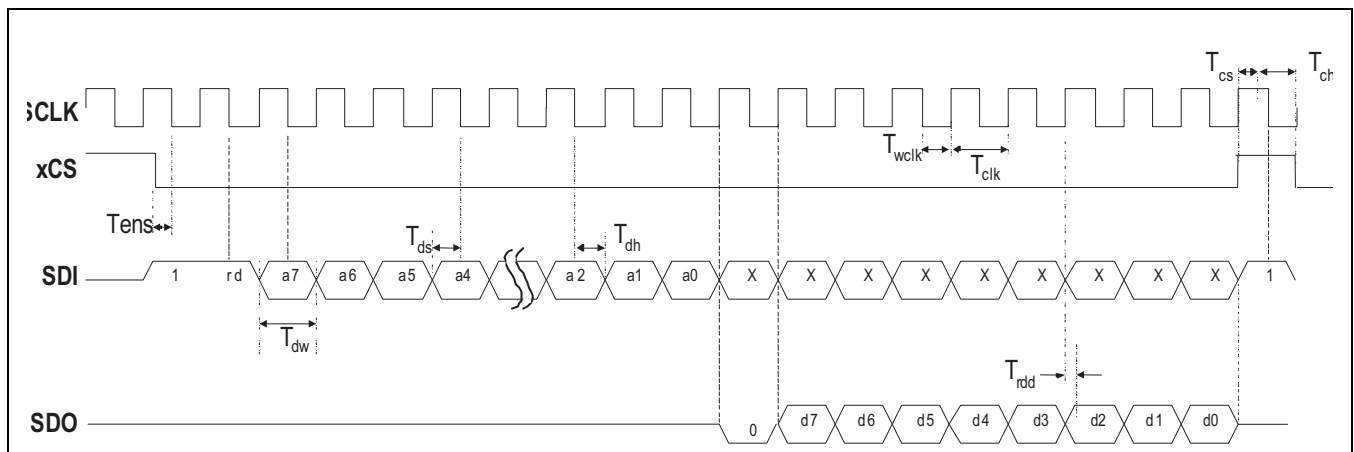

Figure 1-6 illustrates the Serial Read mode where **xCS** goes low before the falling edge of **SCLK**. On each falling edge of **SCLK**, the 10-bits consisting of SB = 1, OP = 1, and the 8-bit ADDR are written to the serial input shift register and copied to the serial output shift register. On the next rising edge after the address LSB, the SB and 8-bits of the DATA are shifted out. The SB for a Read is always 0.

Figure 1-6. Serial READ Mode



On a Write cycle, any bits that follow the expected number of bits are ignored, and only the first 16-bits following SB and OP are used. On a Read cycle, any extra clock cycles will result in the repeat of the data LSB. An invalid SB or OP renders the operation undefined. The falling edge of **xCS** always resets the serial operation for a new Read or Write cycle.

The timing diagrams for the serial write and read operations are shown in Figure 1-5 and Figure 1-6, respectively. Table 1-7 contains the specifications for the various timing parameters for the serial programming interface.

Table 1-7. Serial Interface Timing – Specified at Recommended Operating Conditions

Symbol	Item	Notes	Minimum	Typical	Maximum	Units
t_{dw}	Data width	—	14	—	—	ns
t_{dh}	Data hold time	—	5	—	—	ns
t_{ds}	Data setup time	—	5	—	—	ns
t_{ens}	Enable setup time	—	5	—	—	ns
t_{cs}	Chip select setup time	—	2	—	tclk - 2	ns
t_{ch}	Chip select hold time	—	2	—	—	ns
t_{rdd}	Read data output delay	—	1	—	11	ns
t_{clk}	SCLK period width	—	14	—	—	ns
t_{wclk}	SCLK minimum low duration	—	5	—	tclk - 5	ns
t_r	Output rise time	1	1	—	4	ns
t_f	Output fall time	1	1	—	4	ns

NOTES:

1. Edge rate in the high edge-rate mode. Guaranteed by design.

1.2.9 Two-Wire Serial Interface

The two-wire serial interface is compatible with the I²C standard. The M2125x supports the read/write slave-only mode, 7-bit device address field width, and supports the standard rate of 100 Kbps, fast mode of 400 Kbps, and high-speed mode of 3.4 Mbps. The 7-bit address for the device is determined with **MF** [6:0], which allows for a maximum of 124 unique addresses for this device. The four addresses 00001xx (4, 5, 6, 7) are reserved and should not be used. SDA (**MF11**) and SCL (**MF10**) can drive a maximum of 500 pF each at the maximum rate. During the write mode from the master to the M2125x, data is latched into the internal M2125x registers on the rising edge of SCL, during the acknowledge phase (ACK) of communication. [Table 1-8](#) summarizes the multifunction pins for the two-wire serial interface mode. For further information on timing, please see the I²C bus specification standard.

Table 1-8. Multifunction Pins for Two-Wire Interface

Pin	Function	Description
MF0	Address bit 0	7-bit device address; address bit 0 is LSB, address bit 6 is MSB
MF1	Address bit 1	
MF2	Address bit 2	
MF3	Address bit 3	
MF4	Address bit 4	
MF5	Address bit 5	
MF6	Address bit 6	
MF10	SCL	Clock input
MF11	SDA	Data input/output (open drain)

1.2.10 JTAG

The M2125x supports JTAG external boundary scan, which includes all of the high-speed I/O, as well as the digital I/O. [Table 1-9](#) shows the multifunction pins signal mapping for JTAG testing.

Table 1-9. Multifunction Pins for JTAG

Pin	Function	Description
MF8	TMS	Test select
MF9	TDI	Test data input
MF10	TCK	Test clock
MF11	TDO	Test data output

1.2.11 Input Deterministic Jitter Attenuators

Each of the four input channels contains an independent input equalizer (IE). For the IE, the address N is mapped to the input channel. In the hardwired mode, there is the option to set input equalization on or off. In the two-wire or four-wire serial interface control mode, the default state allows for configurable input equalization settings using *Ineq_ctrl_N* [2:0], for which the setting of 100b is optimized for trace lengths between 10 - 46 inches.

The input equalization settings have been optimized for a variety of backplane PCB applications, such as board traces and cables. For board traces on FR4, the input equalizer can drive trace-lengths of up to 72" at 1.6 Gbps or 60" at 3.2 Gbps. The equalizer has similar high performance on Nelco-13, Arlon 25, Rogers 3003, 4003C, 4340, GeTek PCB materials, and twinaxial cables. The input equalizer was designed to compensate for the deterministic jitter accumulation effects of typical backplane interconnects, which have bandwidths of hundreds of MHz to a few GHz. The equalizers are not expected to make a significant difference in performance with signal data-rates less than 1 Gbps.

Another component of input deterministic jitter is inter-symbol interference (ISI) due to DC offsets. By default, a DC servo-like circuit is enabled to correct for this type of deterministic jitter, and can be disabled by setting *Ineq_ctrl_N* [4] = 0b. The DC servo can also be used to track changes in the common mode for single-ended operation.

[Figure 1-7](#) and [Figure 1-8](#) show the performance of the input equalization at 2.488 Gbps.

Figure 1-7. STS-48 waveform after transmission through 76" of PCB traces (input to M21250)

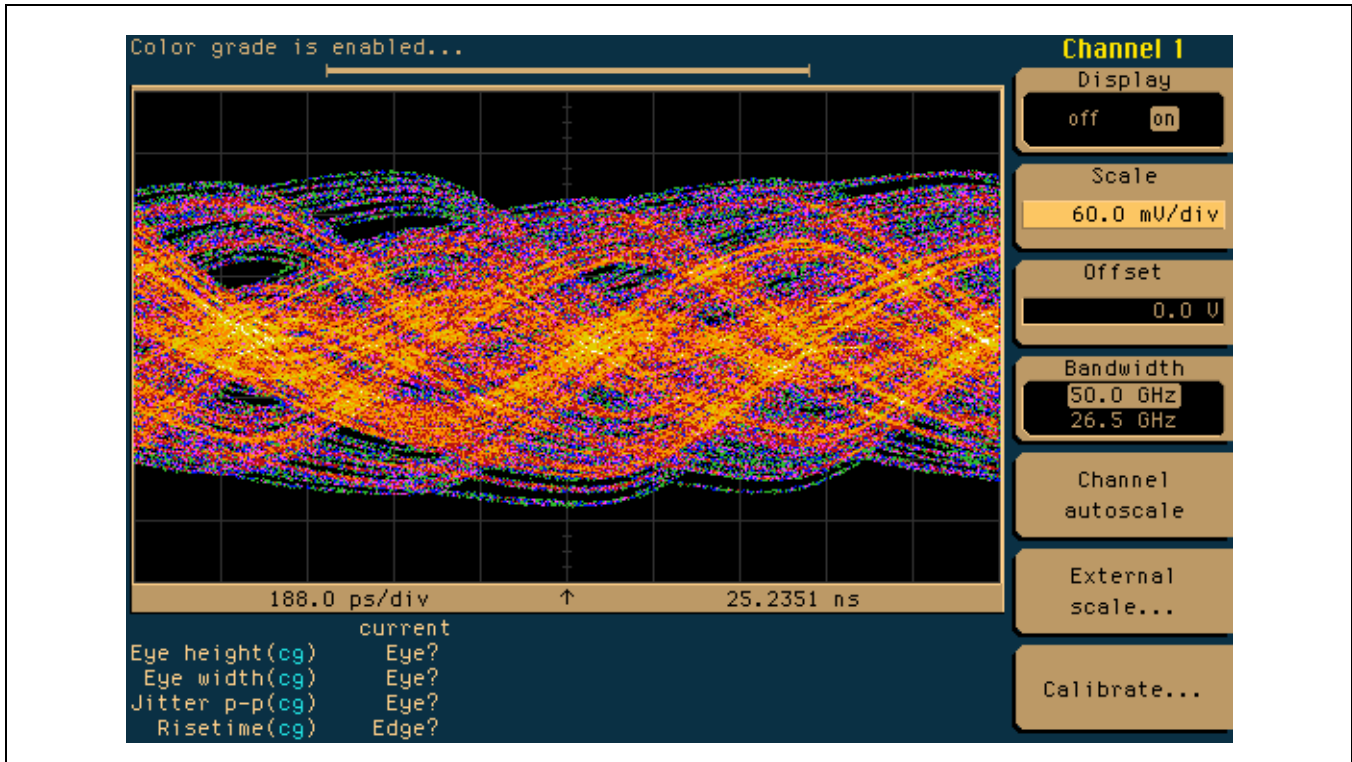
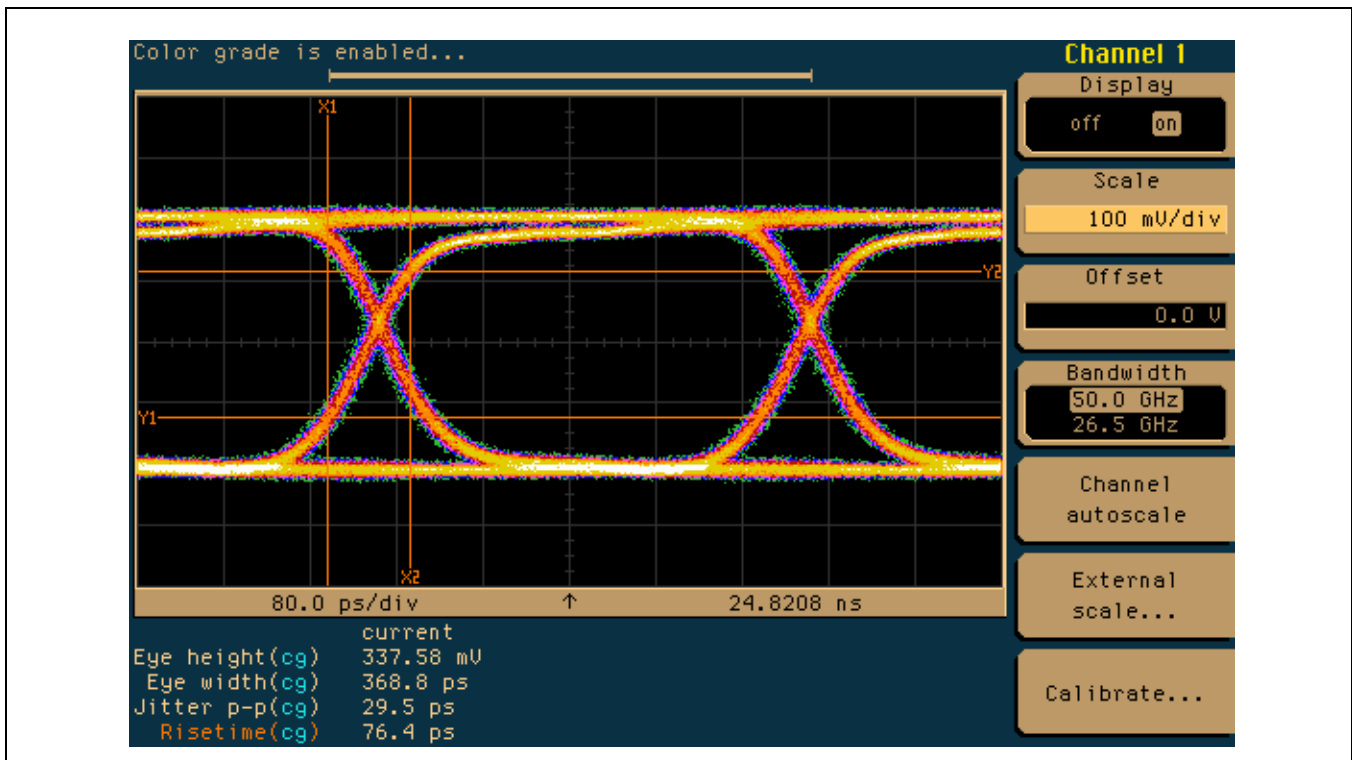

Figure 1-8. STS-48 waveform at M21250 output with input shown in Figure 1-7



1.2.12 Output Pre-Emphasis

Each of the four output channels contains an independent output pre-emphasis circuit that can be used to select the optimal pre-emphasis level. The pre-emphasis settings have been optimized for a variety of backplane and connectivity applications. For board traces on FR4, the pre-emphasis circuit can drive trace-lengths up to 60” at 1.6 Gbps or 40” at 3.2 Gbps. Like the input equalizer settings, the output pre-emphasis circuit has similar high performance on Nelco-13, Arlon 25, Rogers 3003, 4003C, 4340, GeTek PCB materials, and twinaxial cables. The digital pre-emphasis level is selected, for each output channel, with *Preemp_ctrl_N* [2:0], and the default value of 000b corresponds to pre-emphasis disabled. The pre-emphasis circuit tracks the signal data-rate throughout the multi-rate range, however, like the input equalizer, it is designed to compensate for the bandwidth limitations of the interconnect, and may not have the desired effects at the low end of the multi-rate range. The output pre-emphasis function is available for all data interfaces and levels.

Figure 1-9. Definition of Pre-Emphasis Levels

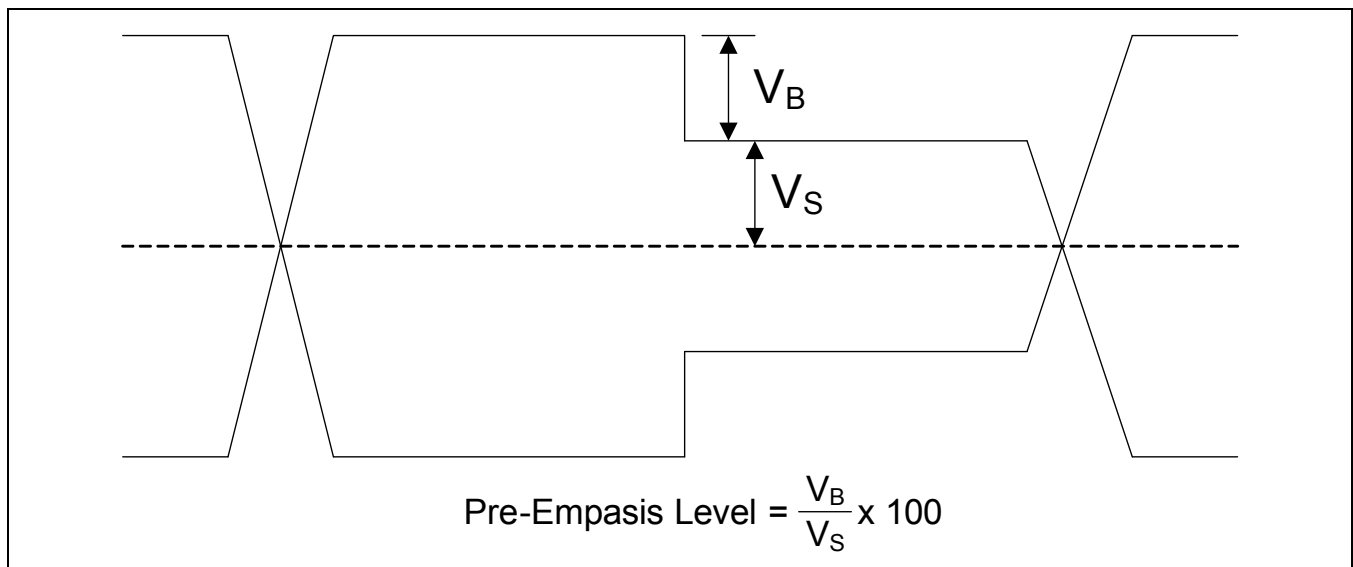

1.2.13 CDR/RCLK Overview

The M2125x contains 4 multi-rate CDR/RCLKs, that can each operate at independent bit rates. When the CDR/RCLK achieves phase lock onto the incoming data stream, it removes the incoming random jitter above its loop bandwidth. The M2125x output data has extremely low jitter, due to retiming with a very low jitter generation CDR/RCLK. Clock outputs are also provided, but are disabled by default.

Each CDR/RCLK is capable of multi-rate operation which is achieved by a combination of built in VCO frequency dividers (VCD), Data Rate Dividers (DRD), and a wide VCO tuning range ($F_{min}=2.0$ GHz, $F_{max} = 3.2$ GHz). As a result, the allowed input data range is F_{min} / DRD_{max} to F_{max} / DRD_{min} . Although the ranges are not continuous, the ranges are deliberately chosen to cover all typical applications.

By default, the loop-bandwidth is set to pass 3G-SDI Video and SONET STS-48 specifications, with less than 0.1 dB of bandwidth peaking. Within a given VCO frequency range, the bandwidth will scale proportionately. For example, if the loop bandwidth (LBW) is 1.19 MHz at 1.485 GHz, then at 2.97 GHz the LBW will be 2.38 MHz, and peaking will be less than 0.1 dB. When DRD is not equal to 1, the bandwidth at DRD=1 scales by the DRD divide ratio. For example, if the LBW is 2.38 MHz at 3G-SDI with DRD=1, then if DRD= 2 for HD operation, the LBW will be 1.19 MHz. In general, the default bandwidth will meet SMPTE specifications for all bit rates down to 143 MHz. Internal filter components assure that the peaking will not exceed 0.1 dB for all DRDs up to 16. In the hardwired

mode, the LBW will be properly set for the hardwired bit rates. In the serial register mode, the default bandwidth scales automatically with the input bit rate, and the bandwidth can be tuned through registers.

The CDR/RCLK requires an external reference clock to be connected to the **RefClkP/N** pins. The CDR/RCLK contains an internal frequency pre-scaler that allows a single reference to be used for multiple bit rates and thereby ease the burden of having to route and switch multiple frequency references.

Frequency acquisition is accomplished with two key sections. The first section is a secondary phase/frequency lock loop (P/FLL) that drives the VCO towards the desired frequency. The second section is the loss-of-lock circuitry (LOLCir), that turns on or off the secondary P/FLL. In general LOL has register bits (*Alarm_LOL*) which are active high, and pins (*xLOL*[3:0]) which are active low, for wired OR use to be wired OR externally. In the general context, they will be referred to as LOL which is active H. With both methods, frequency acquisition takes place when the LOLCir determines an out of lock condition (LOL=H) for each CDR/RCLK, when the VCO frequency exceeds a given range (window). LOLCir enables the secondary P/FLL to drive the VCO close to the desired frequency (the input data bit rate). When the VCO falls within a given frequency range where the CDR/RCLK loop can acquire phase lock, LOLCir turns off the secondary P/FLL and sets LOL=L, allowing the CDR/RCLK to achieve phase lock. During this time, LOLCir continues to monitor the frequency difference and will signal a LOL=H to start the acquisition routine again; if the frequency falls out of range. The LOLCir range is fixed in hardwired mode, and programmable in 2-wire or 4-wire serial interface mode. In general, the frequency threshold (window) for LOL=H-to-L and LOL=L-to-H are different to prevent LOL from toggling when the frequency is near one of the windows. These registers also control the frequency acquisition time. Suggested values are given in this document for general robust operation, and are used as register defaults, however, the programmability of the registers allow for optimization based on a given application (e.g. faster lock times).

1.2.14 General CDR/RCLK Features

All of the CDR/RCLKs are reset upon *xRST=L*, *Mastreset=AAh*, or upon power up. A soft reset through *RCLK_ctrlA_N*[3]=1b resets the individual CDR/RCLK state machine, and presets the CDR/RCLK to an out-of-lock condition, however, the register contents that are related to CDR/RCLK setup are unchanged. It is required to force a soft-reset if the bit rate is dynamically changed. The soft reset register bit needs to be cleared for proper operation. In general, a reset during operation will cause bit errors, until the CDR/RCLK achieves phase lock.

By default, all of the CDR/RCLKs are active and powered up for normal operation. By setting *RCLK_ctrlB_N*[7:6]=11b, a CDR/RCLK can be bypassed and powered down to allow for non-standard bit rates, or to save power when the CDR/RCLK is not required at lower bit rates. When *RCLK_ctrlB_N*[7:6]=01b, the CDR/RCLK is bypassed so the output data is not re-timed but active (VCO locked to the input data). In the last mode with *RCLK_ctrlB_N*[7:6]=10b, the CDR/RCLK is powered down, and all signals along the input and output paths are also powered down, to save power. In this case, the input data does not reach the output, so this setting should only be used to power-down unused channels.

To prevent the propagation of noise in the case where there is a LOL condition, the CDR/RCLK contains an auto-inhibit feature, which is enabled by default. When LOL is active, the output of the CDR/RCLK is fixed at a logic high state (*DoutP=H*, *DoutN=L*). This feature can be disabled by setting *RCLK_ctrlA_N*[3]=0b, which allows *RCLK_ctrlA_N*[5] to either force an inhibit (1b) or to never inhibit (0b).

In some applications, the optimal data sampling point is not in the middle of the data eye. By default, the CDR/RCLK achieves phase lock very near the center of the eye. For optimal performance (jitter tolerance), the actual sampling point can be adjusted with *Phadj_ctrl_N*[3:0]. The adjustment range is from -122.5 mUI to +122.5 mUI with 17.5 mUI steps.

For HD/SD-SDI video applications, Mindspeed has developed a software solution to implement an automatic rate detection (ARD) algorithm. The software code and hardware design for this solution is available. The software code can be modified by customers to include applications other than HD/SD-SDI video.

1.2.15 Multi-Rate CDR Data-Rate Selection

For multi-rate operation, the first step is to determine the desired data-rate range. The input data range must be bracketed by $DF_{min} = F_{vco,min}/DRD_{max}$ to $DF_{max} = F_{vco,max}/DRD_{min}$. $DF_{max/min}$ are the maximum/minimum input data-rate frequencies, $DRD_{max/min}$ are the maximum/minimum data-rate divider settings using CDR_ctrlB_N [3:0], and $F_{vco,min}/F_{vco,max}$ are the minimum/maximum VCO frequencies, which are 2.0 GHz and 3.2 GHz respectively. The valid data-rates are shown in [Table 1-10](#).

Table 1-10. Valid Input Data Ranges

Parameter	DF _{min}	DF _{max}	Units
Data-rate divider (DRD = 1): CDR_ctrlB_N [3:0] = 0000b	2.0	3.2	GHz
Data-rate divider (DRD = 2): CDR_ctrlB_N [3:0] = 0001b	1.0	1.6	GHz
Data-rate divider (DRD = 4): CDR_ctrlB_N [3:0] = 0010b	500	800	MHz
Data-rate divider (DRD = 8): CDR_ctrlB_N [3:0] = 0011b	250	400	MHz
Data-rate divider (DRD = 12): CDR_ctrlB_N [3:0] = 0100b	166.7	266.66	MHz
Data-rate divider (DRD = 16): CDR_ctrlB_N [3:0] = 0101b	125	200	MHz
Data-rate divider (DRD = 24): CDR_ctrlB_N [3:0] = 0110b	83.33	133.33	MHz
Data-rate divider (DRD = 32): CDR_ctrlB_N [3:0] = 0111b	62.5	100	MHz
Data-rate divider (DRD = 48): CDR_ctrlB_N [3:0] = 1000b	42	66.66	MHz

It is important to note the difference between the VCO frequency (F_{vco}), and the data-rate frequency (DF). F_{vco} is always between 2 GHz to 3.2 GHz, while DF is the divided down F_{vco} that matches the input data-rate.

1.2.16 Frequency Acquisition

Frequency acquisition is enabled by the LOLCir when $LOL = H$ ($Alarm_LOL = H$ or $xLOL = L$). A secondary FLL attempts to lock the VCO to a frequency derived from the external reference. When the frequency is close to the desired frequency, LOLCir sets $LOL = L$ and disables the secondary FLL, thus, the main CDR/RCLK PLL is free to phase lock to the incoming data. Although the main CDR/RCLK PLL can achieve frequency lock, the VCO frequency tuning range typically exceeds the CDR/RCLK PLL inherent acquisition range. This implies that the FLL needs to get the VCO within the CDR/RCLK PLL range. The loss of lock circuitry (LOLCir) is used to determine when the secondary FLL is active. The LOLCir consists of window detectors that constantly compare a scaled VCO frequency, to a frequency related to the external reference. When $LOL = H$ the loop is out of lock, the FLL is activated until the frequency difference is within the narrow reference window (NRW). When $LOL = L$, the FLL is not engaged until the frequency exceeds the wide reference window (WRW). If a signal is not present, the FLL circuit will drive the VCO frequency to the NRW and turn off. Without data present, the VCO would then drift until the frequency difference exceeds the WRW, and repeat this cycle. To prevent this, by default, the FLL is activated with $LOL = H$ and de-activated with $LOL = L$.

Figure 1-10. Block Diagram of Frequency Acquisition Circuits

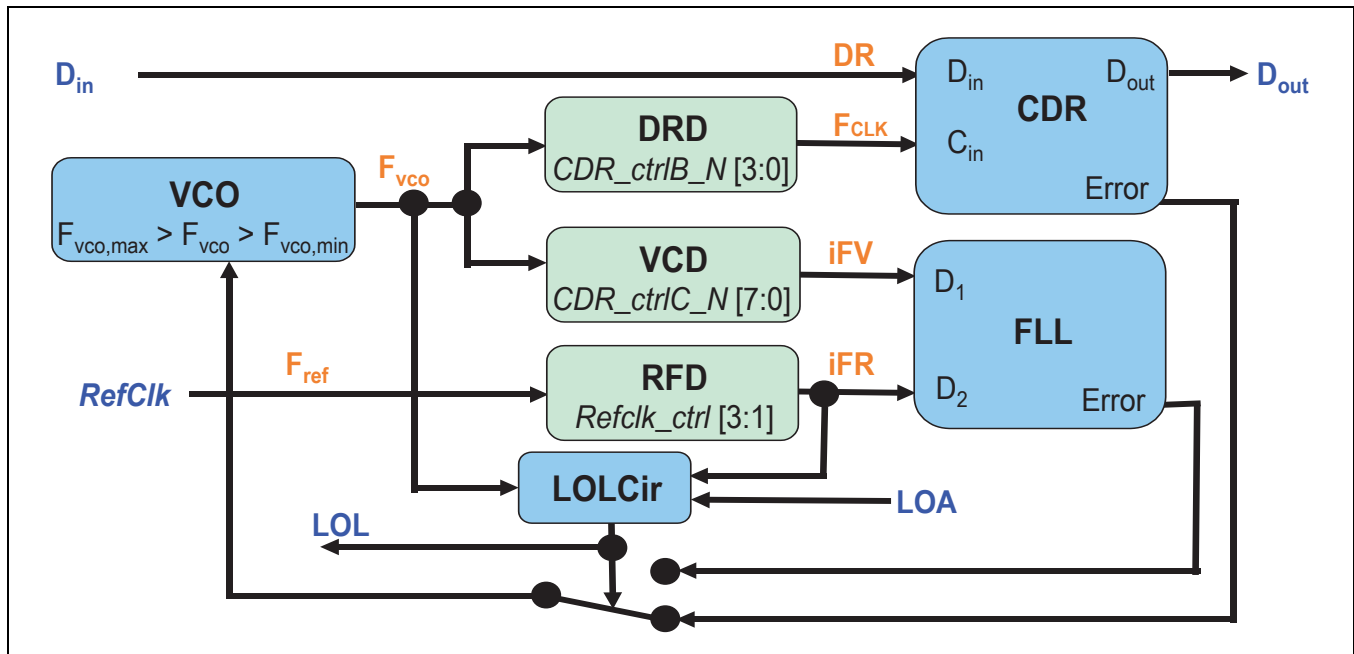

Figure 1-10 shows a block diagram of the frequency acquisition circuits. The secondary FLL compares a scaled version of the internal VCO frequency (iFV) with a scaled version of the reference clock frequency (iFR); iFR and iFV are limited to between 10 MHz and 25 MHz. The external reference clock frequency (F_{ref}) is applied to the **RefClk** [P/N] terminals. This reference frequency is scaled to the iFR by the reference frequency divider (RFD) [*Refclk_ctrl* [3:1]], which allows for an external reference clock in the range of 10 MHz to 800 MHz. The RFD level is a globally set value that applies to all CDR/RCLKs. Table 1-11 gives the divider ratio, along with the minimum and maximum F_{ref} values.

Table 1-11. Reference Clock Frequency Ranges

RFD Value	Minimum F_{ref} (MHz)	Maximum F_{ref} (MHz)
RFD (<i>Refclk_ctrl</i> [3:1] = 000b): divide by 1	10	25
RFD (<i>Refclk_ctrl</i> [3:1] = 001b): divide by 2	20	50
RFD (<i>Refclk_ctrl</i> [3:1] = 010b): divide by 4	40	100
RFD (<i>Refclk_ctrl</i> [3:1] = 011b): divide by 8	80	200
RFD (<i>Refclk_ctrl</i> [3:1] = 100b): divide by 12	120	300
RFD (<i>Refclk_ctrl</i> [3:1] = 101b): divide by 16	160	400
RFD (<i>Refclk_ctrl</i> [3:1] = 110b): divide by 32	320	800

The VCO frequency is scaled to the iFV by the VCO comparison divider (VCD) [*RCLK_ctrlC_N* [7:0]]. Table 1-12 provides DRD, RFD, and VCD values for common applications. For applications that only deal with SONET/SDH data-rates, a 19.44 MHz reference clock frequency must be used. For applications where a combination of SONET/SDH and other data-rates are used, a 25 MHz reference clock frequency must be used. If either of these reference clock frequencies is not available, please contact Mindspeed Technologies Applications Engineering for other options. For applications that only deal with SDI data rates, a 12 MHz reference clock frequency is recommended.

Table 1-12. DRD/RFD/VCD Settings for Different Data-Rates and Reference Frequencies (1 of 2)

Application	DR (Mbps)	Fref (MHz)	DRD	RFD	VCD	Notes
SD-143	143	12	5	—	191	
SD-177	177	12	4	—	177	
SD-270	270	12	3	—	180	
SD-360	360	12	3	—	240	
SD	540	12	2	—	180	
HD	1483.5/1485	12	1	—	247	
3G	2967/2970	12	0	—	247	
10GE - XAUI	3125	156.25	1	8	160	
10GE-XAUI	3125	25	1	2	250	
10GFC - XAUI	3187.5	159.375	1	8	160	
10GFC-XAUI	3187.5	25	1	2	255	1
STS-48+FEC	2666.06	19.44	1	1	137	1
STS-48 + FEC	2666.06	25	1	2	213	1
STS-48	2488.32	155.52	1	8	128	
STS-48	2488.32	19.44	1	1	128	
STS-48	2488.32	25	1	2	199	1
2GFC	2125	106.25	1	8	160	
2GFC	2125	25	1	2	170	
GE	1250	125	2	8	160	
GE	1250	25	2	2	200	
FC	1062.5	106.25	2	8	160	
FC	1062.5	25	2	2	170	1
STS-12	622.08	19.44	4	1	128	
STS-12	622.08	25	4	2	199	1
FC	531	25	4	2	170	1
FC	266	25	12	2	255	1
ESCON	200	10	12	1	240	
ESCON	200	25	12	2	192	
STS-3	155.52	19.44	16	1	128	
STS-3	155.52	25	16	2	199	1
FC	133	25	24	2	255	1
FE	125	12.5	16	1	160	
FE	125	25	24	2	240	
STS-1	51.84	25	48	2	199	1

Table 1-12. DRD/RFD/VCD Settings for Different Data-Rates and Reference Frequencies (2 of 2)

Application	DR (Mbps)	Fref (MHz)	DRD	RFD	VCD	Notes
STS-1	51.84	19.44	48	1	128	1
DS3	44.736	25	48	2	172	1

NOTES:

- Set $LOL_ctrl_N[0] = 1b$, all other bits at default values.

The FLL drives the iFV to iFR, and it is the primary function of the LOLCir to determine when to turn off the FLL, so the CDR/RCLK can achieve phase lock. The LOLCir uses the frequency difference between iFV and iFR to switch LOL, which turns on and off the secondary FLL. The thresholds where LOL makes a transition are defined as windows. These windows are fixed in the hardwired mode, and programmable in the two-wire interface mode. To prevent LOL from toggling at the thresholds, two windows are used for hysteresis. When $LOL = L$ and the frequency difference exceeds the larger window (WRW), LOL L-to-H occurs to signal an out of lock case. When $LOL = H$ (and $LOA = L$), the frequency difference is brought within the narrow reference window (NRW), after which LOL makes a H-to-L transition signaling in-lock. If $LOA = H$ when $LOL = L$, the FLL remains on to keep the VCO locked to the reference, until a signal is present. N_{acq} is defined with $LOL_ctrl_N [7:5]$, N_{narrow} is defined with $LOL_ctrl_N [4:1]$, and N_{wide} is defined with $LOL_ctrl_N [0]$. The LOLCir averages a large number of transitions before making an LOL decision. This averaging time is referred to as the LOL decision time or DT_{LOL} .

Table 1-13 shows various window sizes for different applications, including the default value in both the hardwired and two-wire serial interface modes.

Table 1-13. LOL Window Size and Decision Time Examples

Condition	N_{acq}	N_{narrow}	N_{wide}	Narrow Window (ppm)	Wide Window (ppm)	Decision Time (μs)
Hardwired mode default	101b	0100b	0b	± 1955	± 2930	420
Two-wire serial interface mode default	101b	0100b	0b	± 1955	± 2930	420
iFV = iFR	111b	0010b	1b	± 245	± 975	1685
Fast lock	010b	0001b	0b	± 5860	± 7800	56

NOTES:

- Decision time is calculated with $iFR = 19.44$ MHz; will scale proportionally with iFR range from 10 to 25 MHz.
- Above are examples showing ability to tailor windows for data-rates, reference frequencies, and acquisition times.

1.2.17 CDR/Reclocker Data Rate Programming (3G/HD/SD-SDI Video Rates Only)

If the automatic rate detection (ARD) algorithm developed by Mindspeed is used, it is not necessary for the user to manually program the registers of the CDR/reclockers to configure the CDR/reclockers for operation at a specific data rate. In applications where the ARD is not implemented and the device is used with software control, there are a few parameters that must be configured for the CDR/reclocker to correctly lock to the input data. The parameters that need to be programmed are the data rate divider (DRD) and the VCO frequency divider (VCD). The DRD is programmed using bits [3:0] of register addresses 41h, 51h, 61h, and 71h. The VCD is programmed using bits [7:0] of register addresses 42h, 52h, 62h, and 72h. The following table shows the recommended values of DRD and VCD for standard video data rates.

1.2.18 Ambient Temperature Range Limitations

Table 1-14 summarizes the supported ambient temperature range as a function of data-rate, and indicates when it is required to center the VCO.

Table 1-14. Supported Ambient Temperature Range by Data-Rate

F _{VCO} (GHz)	DR (Gbps)	T _a (°C)	VCO Centering Requirement
2.0 - 2.666	2.0/DRD - 2.666/DRD	-40 - 85	N
2.7 - 2.97	2.7/DRD - 2.97/DRD	0 - 70	N
2.7 - 2.97	2.7/DRD - 2.97/DRD	-40 - 85	Y
3.0 - 3.2	3.0/DRD - 3.2/DRD	0 - 70	Y

F_{VCO} is the VCO frequency, which always lies in the range 2.0 - 3.2 GHz. DR is the data-rate of the input signal, and DRD is the data-rate divider (1, 2, 4, 8, 12, 16, 24, 32, 48) set with *rclk_ctrlB_N*[3:0]. T_a is the ambient temperature supported, which decreases for F_{VCO} > 2.666 GHz. As an example, if the data-rate is 800 Mbps DRD should be set to 4; to lock to this signal the VCO needs to operate at 3.2 GHz. Under these conditions the ambient temperature range supported is 0°C - 70°C, and it is necessary to center the VCO in each of the four lanes.

The VCO tuning range is roughly the same bandwidth as the variation in VCO center frequency between the extremes of the operating temperature range. This issue can be resolved by centering the VCO frequency during the in-circuit testing (ICT) phase prior to shipment of the customer systems.

NOTE: The CDR/RCLK must be powered up and configured at 25°C - 40°C ambient temperature during ICT.

1. Power up the device and configure the registers via the serial interface with the appropriate settings for the application of interest.
2. Read and store the VCO trim code from register MBh[4:0].
3. Every time the device is powered up, this trim code must be forced by setting M0h[0] = 0b then writing the code to MAh[4:0]. This can be done during the same write cycle as when the other registers are configured.

It should be noted that it is not possible to center the VCO in the hardwired mode, it is necessary to program the CDR/RCLK using the serial interface.

1.2.19 Loss of Activity

Loss of activity measures the transition density of data to determine if the data is valid. With PRBS data, the transition density is typically 50%, averaged over long periods. During small time intervals, data transition density variations are due to data content, packet headers, stress patterns, etc. In some applications, when data is not present, noise produces rail-to-rail transitions that cause problems with level based detectors. These applications include cascaded CDR/reclockers, high-gain crosspoints, and other devices. The data transition density based LOA detector can separate data from random noise, determine false lock at the wrong integer and non-integer data-rate, signal stuck high/low conditions, and determine false lock to re-timed noise. Unlike level based detectors, it cannot determine false lock with low amplitude data. The LOA detector is disabled by default, and does not trigger frequency acquisition when enabled and active. The LOA detector is used as part of the off-chip automatic rate detection solution developed by Mindspeed for use in HD/SD-SDI video applications.

1.2.20 Built-In Self Test (BIST) Overview

The M2125x contains a BIST test pattern generator as well as a test pattern receiver. Both the BIST transmitter (BIST Tx), and BIST receiver (BIST Rx) are designed to operate with fixed patterns. For PRBS evaluation, the PRBS 2^7-1 , $2^{15}-1$, $2^{23}-1$, and $2^{31}-1$ test patterns are provided. For 8b/10b testing, the fibre channel CRPAT and CJTPAT standard patterns are supported. In addition, an 8b/10b countdown pattern is also provided; this is the 8b/10b representation of a binary count from 255 to 0, while maintaining 8b/10b running disparity requirements. User programmable 16 bit (PRBS) and 20 bit (8b/10b) patterns are also provided; they are typically used to generate short patterns for debug, such as 1100b, as well as 8b/10b idle or control characters. The BIST is designed to reduce system development time as well as product test costs, and can be used by both the equipment provider as well as the equipment end user.

When enabled, the BIST Rx allows one input from the CDR/RCLK to enter the BIST receiver. The desired channel to monitor is selected through a control register. The BIST Rx uses the recovered clock and data from the selected CDR/RCLK to drive the pattern checker. Every time a bit error is received, the error register is incremented. The maximum number of errors is FFh, and all subsequent errors will not be counted. At any time, the error register can be cleared. By keeping track of the time between a clear and a read, a rough BER number can be obtained.

When enabled, the BIST Tx can broadcast the output test pattern to output channels 0 and 1 (the BIST Tx and Rx can be used at the same time). The BIST Tx contains an internal clock multiplier (PLL), that can take its input from either the external reference frequency, or from the same CDR/RCLK that is driving the BIST Rx (only in full-rate mode, DRD=1).

1.2.21 BIST Test Patterns

The test pattern is selected with *BISTtx_ctrl* [5:2] for the transmitter, and *BISTrx_ctrl* [5:2] for the receiver.

The PRBS patterns generated by the unit are ITU-T 0.151 compliant, and summarized in the table below.

Table 1-15. BIST PRBS Patterns

<i>BISTtx_ctrl</i> [5:2] / <i>BISTrx_ctrl</i> [5:2]	Pattern	Polynomial
0000b	PRBS 2^7-1	2^7+2^6+1
0001b	PRBS $2^{15}-1$	$2^{15}+2^{14}+1$
0010b	PRBS $2^{23}-1$	$2^{23}+2^{18}+1$
0011b	PRBS $2^{31}-1$	$2^{31}+2^{28}+1$

For 8b/10b data, three patterns are available. The CJTPAT and CRPAT comply with the Fibre Channel T11.2/Project 1230/Rev10 specifications.

Table 1-16. BIST 8b/10b Patterns

<i>BISTtx_ctrl</i> [5:2] / <i>BISTrx_ctrl</i> [5:2]	Pattern
0100b	CJTPAT
0101b	CRPAT
0110b	Countdown

Two user programmable patterns that are 16 bits long (*BISTtx_ctrl* [5:2] = *BISTrx_ctrl* [5:2] = 0111b) and 20 bits long (*BISTtx_ctrl* [5:2] = *BISTrx_ctrl* [5:2] = 1000b) are determined with *BIST_pattern0*, *BIST_pattern1*,

BIST_pattern2. Note that the contents of these registers is used by both the BIST Tx and the BIST Rx if they are setup in this mode.

1.2.22 BIST Receiver (BIST Rx) Operation

The BIST Rx is enabled and powered up by setting *BISTrx_ctrl*[1] = 1b (off by default), resetting the BIST Rx block with *BISTrx_ctrl*[0] = 1b (default), and selecting a pattern with *BISTrx_ctrl*[5:2]. The signal to the BIST Rx is routed from the input of the device, and the BIST Rx can only check one channel at a time. The desired channel to monitor is selected with *BISTrx_chsel*[2:0]. The BIST Rx uses the recovered clock from the CDR/RCLK to drive the BIST state-machine, thus the CDR/RCLK must be enabled and locked to data for proper operation. When the data is valid, *BISTrx_ctrl*[6] = 1b is used to clear the error register, and all subsequent errors can be read back through *BISTrx_error*. The BIST Rx automatically synchronizes the input data with the pattern.

1.2.23 BIST Transmitter (BIST Tx) Operation

The BIST Tx is enabled and powered up by setting *BISTtx_ctrl*[1] = 1b (off by default), resetting the BIST Tx block with *BISTtx_ctrl*[0] = 1b (default), and selecting a pattern with *BISTtx_ctrl*[5:2]. The BIST Tx can multicast the test pattern to channels 0 and 1 selected with *BISTtx_chsel*[1:0]. The high-speed clock of the BIST Tx is generated from its own frequency multiplier PLL, that uses a selectable frequency reference determined by *BISTtx_ctrl*[6]. With *BISTtx_ctrl*[6] = 0b (default), the external reference clock is used and typically gives the lowest jitter output. With *BISTtx_ctrl*[6] = 1b the reference clock is derived from the same CDR/RCLK used to drive the BIST Rx (this feature only works with DRD = 1 for that CDR/RCLK). In this mode, the BIST Tx output is synchronous with the CDR/RCLK used in the BIST Rx, however, it contains the low-frequency jitter from the input data. In either case, the BIST Tx PLL needs to be configured for the proper data-rate. When the PLL is properly configured and locked to the reference, the LOL flag should be low (*BISTtx_alarm*[7]). A bit error can be intentionally inserted into the BIST Tx output, by providing a 0b, 1b, 0b sequence to *BISTtx_ctrl*[7].

The BIST Tx PLL setup is similar to the CDR/RCLK setup, thus, the description of similar registers for the CDR/RCLK also applies and will not be repeated here. The desired output data-rate is set with the DRD register (*BISTtx_PLL_ctrlB*[3:0]) and with the VCD register (*BISTtx_PLL_ctrlC*[7:0]). Like the CDR/RCLKs, if the output data-rate of the BIST Tx needs to be changed, the BIST Tx requires a softreset.

1.2.24 Junction Temperature Monitor

An internal junction temperature monitor with a range of -40°C to 130°C is integrated into the M2125x. On the low end, the temperature monitor (Tmon) is set to measure -40°C to 10°C in six 10°C steps, and on the high end, 80°C to 130°C in six 10°C steps. The typical temperature resolution is 3°C . The temperature monitor is enabled with *Temp_mon*[1] = 1b. When enabled, the temperature measurement cycle is achieved by providing a rising edge for *Temp_mon*[0]. Afterwards, the correct temperature can be read from *Temp_value*[3:0]. [Table 1-17](#) shows the mapping of the temperature to *Temp_value*[3:0]. Enabling and strobing the temperature in the same write cycle will not yield reliable results.

Table 1-17. Junction Temperature Monitor

Junction Temperature	Temp_value [3:0]	Condition
$T_c \geq 130^\circ\text{C}$	1100b	High-alarm
$130^\circ\text{C} > T_c \geq 120^\circ\text{C}$	1011b	High-alarm
$120^\circ\text{C} > T_c \geq 110^\circ\text{C}$	1010b	High-warning
$110^\circ\text{C} > T_c \geq 100^\circ\text{C}$	1001b	Normal
$100^\circ\text{C} > T_c \geq 90^\circ\text{C}$	1000b	Normal
$90^\circ\text{C} > T_c \geq 80^\circ\text{C}$	0111b	Normal
$80^\circ\text{C} > T_c \geq 10^\circ\text{C}$	0110b	Normal
$10^\circ\text{C} > T_c \geq 0^\circ\text{C}$	0101b	Normal
$0^\circ\text{C} > T_c \geq -10^\circ\text{C}$	0100b	Normal
$-10^\circ\text{C} > T_c \geq -20^\circ\text{C}$	0011b	Normal
$-20^\circ\text{C} > T_c \geq -30^\circ\text{C}$	0010b	Low-warning
$-30^\circ\text{C} > T_c \geq -40^\circ\text{C}$	0001b	Low-alarm
$-40^\circ\text{C} > T_c$	0000b	Low-alarm

1.2.25 IC Identification / Revision Code

The IC identification can be read back from *Chipcode*, and the revision of the device can be read back from *Revcode*. The assigned chip-code and rev-code for the M21250 is detailed in [Table 1-18](#).

Table 1-18. IC Identification/Revision Code Details

Device	Operating Data Rate	Chipcode	Revcode
M21250/M21250G	42 - 3200 Mbps	16h	23h

1.3 Pin Definitions

Table 1-19. Power Pins

Pin Number	Pin Name	Function	Type
Exposed pad	Vss	IC ground	Power
1, 31, 54, 63, 64	AVdd_I/O	Analog I/O positive supply	Power
21, 27, 28, 34, 57, 60, 67, 70	AVdd_Core	Analog core positive supply	Power
10	DVdd_I/O	Digital I/O positive supply	Power
11, 22, 33	DVdd_Core	Digital core positive supply	Power

NOTES:

1. If internal regulator is enabled, connect all of the **AVdd_Core** and/or **DVdd_Core** pins together to a common floating plane and bypass to **Vss**.
2. If internal regulator is NOT enabled, it is recommended that all **AVdd_Core** pins be tied to a plane at 1.2V that is bypassed to ground. **DVdd_Core** can be tied to this plane or separately decoupled.
3. IC ground (**Vss**) is established by contact with exposed pad on underside of package; there are no **Vss** pins.

Table 1-20. High-Speed Signal Pins

Pin Number	Pin Name	Function	Termination	Type
19	<i>Din0P</i>	Serial positive data input for channel 0	50 Ω pull up to <i>VddT0/1</i>	I - PCML referenced to <i>AVdd_Core</i>
20	<i>Din0N</i>	Serial negative data input for channel 0	50 Ω pull up to <i>VddT0/1</i>	I - PCML referenced to <i>AVdd_Core</i>
25	<i>Din1P</i>	Serial positive data input for channel 1	50 Ω pull up to <i>VddT0/1</i>	I - PCML referenced to <i>AVdd_Core</i>
26	<i>Din1N</i>	Serial negative data input for channel 1	50 Ω pull up to <i>VddT0/1</i>	I - PCML referenced to <i>AVdd_Core</i>
29	<i>Din2P</i>	Serial positive data input for channel 2	50 Ω pull up to <i>VddT2/3</i>	I - PCML referenced to <i>AVdd_Core</i>
30	<i>Din2N</i>	Serial negative data input for channel 2	50 Ω pull up to <i>VddT2/3</i>	I - PCML referenced to <i>AVdd_Core</i>
35	<i>Din3P</i>	Serial positive data input for channel 3	50 Ω pull up to <i>VddT2/3</i>	I - PCML referenced to <i>AVdd_Core</i>
36	<i>Din3N</i>	Serial negative data input for channel 3	50 Ω pull up to <i>VddT2/3</i>	I - PCML referenced to <i>AVdd_Core</i>
23	<i>VddT0/1</i>	Termination pin for <i>Din</i> [1:0]	Terminate to <i>AVdd_Core</i>	Termination
32	<i>VddT2/3</i>	Termination pin for <i>Din</i> [3:2]	Terminate to <i>AVdd_Core</i>	Termination
72	<i>Dout0P</i>	Serial positive data output for channel 0	50 Ω pull up to <i>AVdd_I/O</i>	O - CML/LVDS
71	<i>Dout0N</i>	Serial negative data output for channel 0	50 Ω pull up to <i>AVdd_I/O</i>	O - CML/LVDS
66	<i>Dout1P</i>	Serial positive data output for channel 1	50 Ω pull up to <i>AVdd_I/O</i>	O - CML/LVDS
65	<i>Dout1N</i>	Serial negative data output for channel 1	50 Ω pull up to <i>AVdd_I/O</i>	O - CML/LVDS
62	<i>Dout2P</i>	Serial positive data output for channel 2	50 Ω pull up to <i>AVdd_I/O</i>	O - CML/LVDS
61	<i>Dout2N</i>	Serial negative data output for channel 2	50 Ω pull up to <i>AVdd_I/O</i>	O - CML/LVDS
56	<i>Dout3P</i>	Serial positive data output for channel 3	50 Ω pull up to <i>AVdd_I/O</i>	O - CML/LVDS
55	<i>Dout3N</i>	Serial negative data output for channel 3	50 Ω pull up to <i>AVdd_I/O</i>	O - CML/LVDS
3	<i>Cout0P</i>	Serial positive clock output for channel 0	50 Ω pull up to <i>AVdd_I/O</i>	O - CML/LVDS
2	<i>Cout0N</i>	Serial negative clock output for channel 0	50 Ω pull up to <i>AVdd_I/O</i>	O - CML/LVDS
69	<i>Cout1P</i>	Serial positive clock output for channel 1	50 Ω pull up to <i>AVdd_I/O</i>	O - CML/LVDS
68	<i>Cout1N</i>	Serial negative clock output for channel 1	50 Ω pull up to <i>AVdd_I/O</i>	O - CML/LVDS
59	<i>Cout2P</i>	Serial positive clock output for channel 2	50 Ω pull up to <i>AVdd_I/O</i>	O - CML/LVDS
58	<i>Cout2N</i>	Serial negative clock output for channel 2	50 Ω pull up to <i>AVdd_I/O</i>	O - CML/LVDS
53	<i>Cout3P</i>	Serial positive clock output for channel 3	50 Ω pull up to <i>AVdd_I/O</i>	O - CML/LVDS
52	<i>Cout3N</i>	Serial negative clock output for channel 3	50 Ω pull up to <i>AVdd_I/O</i>	O - CML/LVDS

Table 1-21. Control, Interface, and Alarm Pins

Pin Number	Pin Name	Function	Default	Type
4	MF0	Multifunction pin for hardwired mode, and serial interface	Internal pull up	I - CMOS
5	MF1	Multifunction pin for hardwired mode, and serial interface	Internal pull up	I - CMOS
6	MF2	Multifunction pin for hardwired mode, and serial interface	Internal pull up	I - CMOS
7	MF3	Multifunction pin for hardwired mode, and serial interface	Internal pull up	I - CMOS
13	MF4	Multifunction pin for hardwired mode, and serial interface	Internal pull up	I - CMOS
14	MF5	Multifunction pin for hardwired mode, and serial interface	Internal pull up	I - CMOS
15	MF6	Multifunction pin for hardwired mode, and serial interface	Internal pull up	I - CMOS
41	MF7	Multifunction pin for hardwired mode	Internal pull up	I - CMOS
50	MF8	Multifunction pin for hardwired mode, and JTAG	Internal pull up	I - CMOS
51	MF9	Multifunction pin for hardwired mode, and JTAG	Internal pull up	I - CMOS
12	MF10	Multifunction pin for hardwired mode, serial interface, and JTAG	Internal pull up	I - CMOS
16	MF11	Multifunction pin for hardwired mode, serial interface, and JTAG	Internal pull up	I - CMOS
8	CTRL_Mode0	Hardwired or serial interface mode control pin	Internal pull up	I - CMOS
9	CTRL_Mode1	Hardwired or serial interface mode control pin	Internal pull up	I - CMOS
42	Out_Mode0	Output data interface control pin	Internal pull down	I - CMOS
43	Out_Mode1	Output data interface control pin	Internal pull down	I - CMOS
40	xRST	Reset pin (L = reset)	Internal pull up	I - CMOS
17	xJTAG_En	JTAG testing control pin (L = enable)	Internal pull up	I - CMOS
24	xRegu_En	Internal voltage regulator control pin (L = enable)	Internal pull up	I - CMOS
45	RefClkP	Reference clock positive input	Internal pull down	I - AC coupled
44	RefClkN	Reference clock negative input	Internal pull down	I - AC coupled
18	xL0L0	CDR/reclocker loss of lock alarm for channel 0 (Active Low)	No internal pull up/ pull down	O - open drain
37	xL0L1	CDR/reclocker loss of lock alarm for channel 1 (Active Low)	No internal pull up/ pull down	O - open drain
38	xL0L2	CDR/reclocker loss of lock alarm for channel 2 (Active Low)	No internal pull up/ pull down	O - open drain
39	xL0L3	CDR/reclocker loss of lock alarm for channel 3 (Active Low)	No internal pull up/ pull down	O - open drain
46	xL0A0	CDR/reclocker loss of activity alarm for channel 0 (Active Low)	No internal pull up/ pull down	O - open drain
47	xL0A1	CDR/reclocker loss of activity alarm for channel 1 (Active Low)	No internal pull up/ pull down	O - open drain
48	xL0A2	CDR/reclocker loss of activity alarm for channel 2 (Active Low)	No internal pull up/ pull down	O - open drain
49	xL0A3	CDR/reclocker loss of activity alarm for channel 3 (Active Low)	No internal pull up/ pull down	O - open drain

Figure 1-11. M2125x Pinout Diagram (Top View)

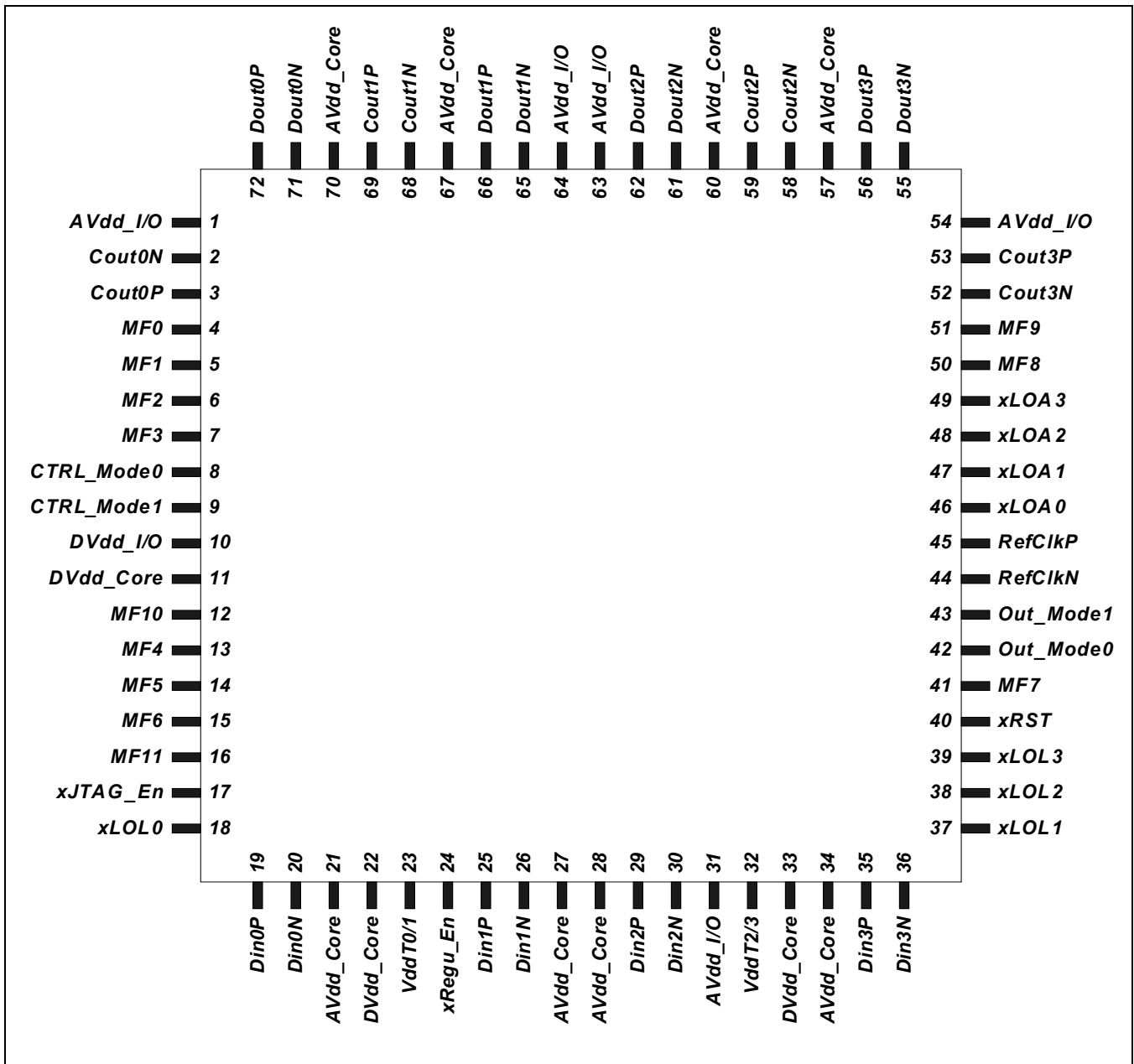



2.0 Product Specifications

2.1 Absolute Maximum Ratings

These are the absolute maximum ratings at or beyond which the device can be expected to fail or be damaged. Reliable operation at these extremes for any length of time is not warranted.

Table 2-1. Absolute Maximum Ratings

Symbol	Parameter	Notes	Minimum	Typical	Maximum	Units
DVdd_I/O	Digital I/O power	1	0	1.8/2.5/3.3	3.6	V
AVdd_I/O	Analog I/O power	1	0	1.8/2.5/3.3	3.6	V
AVdd_Core	Analog core power	1, 2	0	1.2	1.5	V
DVdd_Core	Digital core power	1, 2	0	1.2	1.5	V
—	High-speed signal pins	1, 4	V_{ss} - 0.5	—	AVdd_I/O + 0.5	V
—	Control, interface, and alarm pins	1, 5	V_{ss} - 0.5	—	DVdd_I/O + 0.5	V
T _{st}	Storage temperature	1	-65	—	+150	°C
ESD	Human body model (low-speed)	1	2000	—	—	V
ESD	Human body model (high-speed)	1	350	—	—	V
ESD	Charged device model	1	100	—	—	V
—	Maximum DC input current	1, 3	—	—	25	mA

NOTES:

1. No damage under these conditions.
2. Apply voltage to core pin if internal regulator is disabled. If enabled, pins should be floating with by-pass to **V_{ss}**.
3. Computed as the current through 50 Ω from the voltage difference between the input voltage common mode and **V_{ddT}**.
4. High-speed signal pins are shown in [Table 1-20](#).
5. Control, interface, and alarm pins are shown in [Table 1-21](#).

2.2 Recommended Operating Conditions

Table 2-2. Recommended Operating Conditions

Symbol	Parameter	Notes	Minimum	Typical	Maximum	Units
DVdd_I/O	Digital I/O power	2	—	1.8/2.5/3.3	—	V
AVdd_I/O	Analog I/O power	2	—	1.8/2.5/3.3	—	V
AVdd_Core	Analog core power	1, 2	—	1.2	—	V
DVdd_Core	Digital core power	1, 2	—	1.2	—	V
T _a	Ambient temperature	4	-40	—	85	°C
θ _{ja}	Junction to ambient thermal resistance	3	—	24	—	°C/W

NOTES:

1. Needed only if **AVdd_Core** or **DVdd_Core** are provided from external source (internal regulator disabled **xRegu_En** = H).
2. Typical value +/- 5% is acceptable.
3. With forced convection of 1 m/s and 2.5 m/s, θ_{ja} is decreased to 18 °C/W and 16 °C/W respectively.
4. See [Section 1.2.18, “Ambient Temperature Range Limitations,”](#) on page 18.

2.3 Power Dissipation

Table 2-3. DC Power Electrical Specifications (1 of 2)

Symbol	Parameter	Notes	Minimum	Typical	Maximum	Units
I _{dd}	Case 1: current consumption for output swing = 550 mV CML, internal regulator = on, clock outputs = off	1	—	310	365	mA
P _{diss}	Power dissipation at 1.8V	—	—	560	660	mW
P _{diss}	Power dissipation at 3.3V	2	—	1.02	1.2	W
I _{dd}	Case 2: current consumption for output swing = 550 mV CML, internal regulator = on, clock outputs = on	1	—	370	435	mA
P _{diss}	Power dissipation at 1.8V	—	—	670	780	mW
P _{diss}	Power dissipation at 3.3V	2	—	1.22	1.44	W
I _{dd}	Case 3: current consumption for output swing = 900 mV CML, internal regulator = on, clock outputs = off	1	—	340	400	mA
P _{diss}	Power dissipation at 1.8V	—	—	610	720	mW
P _{diss}	Power dissipation at 3.3V	2	—	1.12	1.32	W
I _{dd}	Case 4: current consumption for output swing = 900 mV CML, internal regulator = on, clock outputs = on	1	—	420	490	mA
P _{diss}	Power dissipation at 1.8V	—	—	760	880	mW
P _{diss}	Power dissipation at 3.3V	2	—	1.39	1.62	W
	Case 5: output swing = 550 mV CML, internal regulator = off, clock outputs = off	1				
I _{dd_core}	Core current consumption	—	—	260	300	mA
I _{dd_io}	Input/Output buffers current consumption	—	—	50	70	mA

Table 2-3. DC Power Electrical Specifications (2 of 2)

Symbol	Parameter	Notes	Minimum	Typical	Maximum	Units
Pdiss	Power dissipation at 1.2V core, 1.8V I/O	—	—	400	490	mW
Pdiss	Power dissipation at 1.2V core, 3.3V I/O	—	—	480	590	mW
	Case 6: output swing = 550 mV CML, internal regulator = off, clock outputs = on	1				
Idd_core	Core current consumption	—	—	285	330	mA
Idd_io	Input/Output buffers current consumption	—		100	125	mA
Pdiss	Power dissipation at 1.2V core, 1.8V I/O	—	—	520	620	mW
Pdiss	Power dissipation at 1.2V core, 3.3V I/O	—	—	670	810	mW
Idd	Case 7: current consumption for output swing = 450 mV LVDS, internal regulator = on, clock outputs = off	1	—	320	380	mA
Pdiss	Power dissipation at 1.8V	—	—	580	680	mW
Pdiss	Power dissipation at 3.3V	2	—	1.06	1.25	W
Idd	Case 8: current consumption for output swing = 1.5V PCML+, internal regulator = on, clock outputs = off	1	—	410	470	mA
Pdiss	Power dissipation at 1.8V	—	—	740	850	mW
Pdiss	Power dissipation at 3.3V	2	—	1.35	1.55	W
NOTES:						
1. Specified at recommended operating conditions – see Table 2-2 .						
2. Thermal design such as thermal pad vias on PCB must be considered for this case.						

2.4 Input/Output Specifications

Table 2-4. Serial Interface (2-Wire and 4-Wire) CMOS I/O Electrical Specifications

Symbol	Parameter	Notes	Minimum	Typical	Maximum	Units
V _{OH}	Output logic high I _{OH} = -3 mA	2	0.8 x DV _{dd_I/O}	DV _{dd_I/O}	—	V
V _{OL}	Output logic low I _{OL} = 24 mA	2	—	0.0	0.2 x DV _{dd_I/O}	V
I _{OH}	Output current (logic high)	—	-10	—	0	mA
I _{OL}	Output current (logic low)	—	0	—	10	mA
V _{IH}	Input logic high	—	0.75 x DV _{dd_I/O}	—	DV _{dd_I/O} + 0.3	V
V _{IL}	Input logic low	—	0	—	0.25 x DV _{dd_I/O}	V
I _{IH}	Input current (logic high)	—	-100	—	100	μA
I _{IL}	Input current (logic low)	—	-100	—	100	μA
t _r	Output rise time (20-80%)	—	—	—	250	ns
t _f	Output fall time (20-80%)	—	—	—	250	ns
C2wire	Input capacitance of MF10 & MF11 in 2-wire serial interface mode.	3	—	—	10	pF

NOTES:

- Entire table specified at recommended operating conditions – see Table 2-2.
- DV_{dd_I/O} can be chosen independently from AV_{dd_I/O}.
- 2-Wire serial output mode can drive 500 pF.

Table 2-5. Input Electrical Specifications

Symbol	Parameter	Notes	Minimum	Typical	Maximum	Units
DR _{IN}	Input signal data-rate	—	42	—	3200 (M21250) 1600 (M21251) 540 (M21252)	Mbps
V _{ID}	Input differential voltage (P-P)	2, 3	100	—	2000	mV
V _{ICM}	Input common-mode voltage	—	700	—	1200	mV
V _{IH}	Maximum input high voltage	—	—	—	AV _{dd_Core} + 400	mV
V _{IL}	Minimum input low voltage	—	400	—	—	mV
R _{IN}	Input termination to V _{ddT}	4	45	50	65	Ω
S ₁₁	Input return loss (40 MHz to 2.5 GHz)	—	—	-15.0	—	dB

NOTES:

- Entire table specified at recommended operating conditions – see Table 2-2.
- Example 1200 mV_{pp} differential = 600 mV_{pp} for each single-ended terminal.
- Minimum input level defined as error free operation at 10⁻¹² BER.
- See Figure 2-1 for input termination circuit.

Figure 2-1. Data Input Internal Circuitry

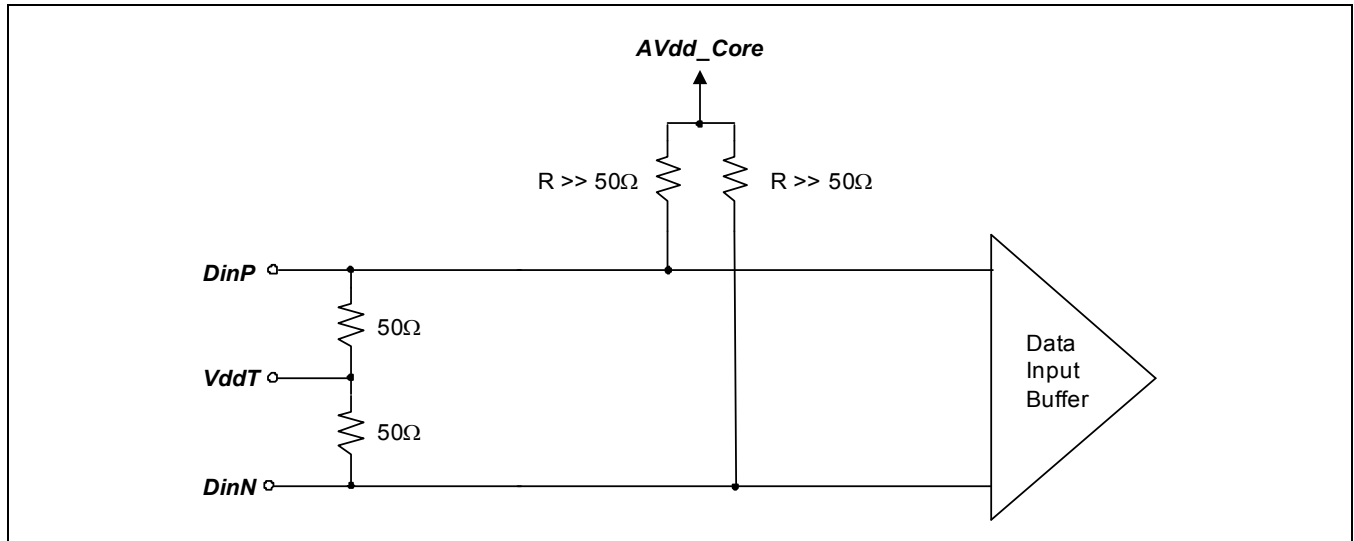

Table 2-6. PCML (Positive Current Mode Logic) Output Electrical Specifications

Symbol	Parameter	Notes	Minimum	Typical	Maximum	Units
DR_{OUT}	Output signal data-rate (CDR/reclockers enabled)	—	42	—	3200 (M21250) 1600 (M21251) 540 (M21252)	Mbps
t_r/t_f	Rise/Fall time (20-80%) for all levels	5	—	75	130	ps
V_{OH}	Low swing: output logic high (single-ended)	5	$AVdd_{I/O} - 55$	—	$AVdd_{I/O}$	mV
V_{OL}	Low swing: output logic low (single-ended)	5	$AVdd_{I/O} - 370$	—	$AVdd_{I/O} - 250$	mV
V_{OD}	Low swing: differential swing	2, 4, 5	400	550	750	mV
V_{OH}	Medium swing: output logic high (single-ended)	5	$AVdd_{I/O} - 80$	—	$AVdd_{I/O}$	mV
V_{OL}	Medium swing: output logic low (single-ended)	5	$AVdd_{I/O} - 600$	—	$AVdd_{I/O} - 420$	mV
V_{OD}	Medium swing: differential swing	2, 5	700	900	1150	mV
CV_{OD}	Clock output differential swing: medium swing	—	600	—	—	mV
V_{OH}	High swing: output logic high (single-ended)	5	$AVdd_{I/O} - 95$	—	$AVdd_{I/O}$	mV
V_{OL}	High swing: output logic low (single-ended)	5	$AVdd_{I/O} - 770$	—	$AVdd_{I/O} - 535$	mV
V_{OD}	High swing: differential swing	2, 4, 5	900	1200	1500	mV
V_{OH}	PCML+: output logic high (single-ended)	5	$AVdd_{I/O} - 115$	—	$AVdd_{I/O}$	mV
V_{OL}	PCML+: output logic low (single-ended)	5	$AVdd_{I/O} - 1000$	—	$AVdd_{I/O} - 680$	mV
V_{OD}	PCML+: differential swing	2, 4, 5	1150	1500	1900	mV

Table 2-6. PCML (Positive Current Mode Logic) Output Electrical Specifications

Symbol	Parameter	Notes	Minimum	Typical	Maximum	Units
R _{OUT}	Output termination to <i>AVdd_I/O</i>	—	45	50	65	Ω
S ₂₂	Output return loss (40 MHz to 2.5 GHz)	—	—	-15.0	—	dB

NOTES:

1. Entire table specified at recommended operating conditions – see [Table 2-2](#).
2. Example 1200 mV_{P-P} differential = 600 mV_{P-P} for each single-ended terminal.
3. All output swings defined with pre-emphasis off.
4. Clock output swing is typically 25% less than data output swing.
5. Refer to [Figure 2-2](#) for definitions of eye parameters.

Table 2-7. LVDS (Low Voltage Differential Signal) Output Electrical Specifications

Symbol	Parameter	Notes	Minimum	Typical	Maximum	Units
DR _{OUT}	Output Signal Data Rate (CDR/reclockers enabled)	—	42	—	3200 (M21250) 1600 (M21251) 540 (M21252)	Mbps
V _{OCM}	Output average common mode range	2	—	1200	—	mV
t _r /t _f	GPL: rise/fall time (20-80%)	6	—	75	130	ps
V _{OD}	GPL: differential output (P-P)	3, 6	500	650	800	mV
V _{OD}	RRL: differential output (P-P)	6	300	450	550	mV
R _{OUT}	Output termination (differential)	—	90	100	130	Ω
S ₂₂	Output return loss (40 MHz to 2.5 GHz)	—	—	-15.0	—	dB

NOTES:

1. Entire table specified at recommended operating conditions - see [Table 2-2](#).
2. Computed as average (average positive output and average negative output).
3. Conforms to IEEE Std 1596.3-1996 for GPL. All values specified for 50Ω single-ended back-match, 100Ω differential load.
4. All output swings defined with pre-emphasis off.
5. Clock output swing is typically 25% less than data output swing.
6. Refer to [Figure 2-2](#) for definitions of eye parameters.

Figure 2-2. Definitions of Eye Parameters

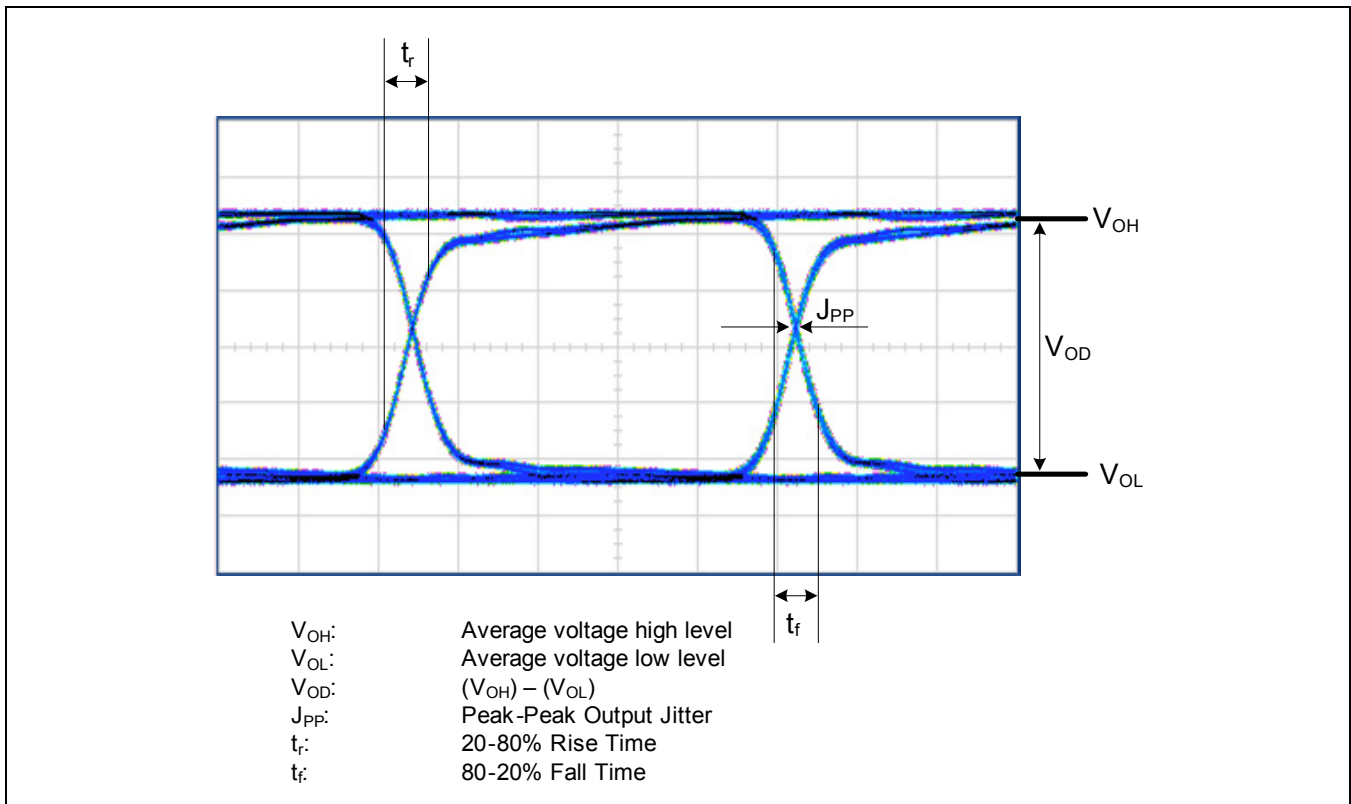

Table 2-8. Input Equalization Performance Specifications

Symbol	Parameter	Notes	Minimum	Typical	Maximum	Units
DR_{IN}	Input signal data-rate	—	42	—	3200 (M21250) 1600 (M21251) 540 (M21252)	Mbps
—	Maximum error-free distance at 3.2 Gbps	2, 3, 6, 7	—	—	60	in
—	Maximum error-free distance at 1.6 Gbps	2, 3, 6, 7	—	—	72	in

NOTES:

- Entire table specified at recommended operating conditions – see Table 2-2.
- Performance measured on standard FR4 backplane such as standards provided by TYCO for 10GE XAUI.
- Measured with PCML driver without output pre-emphasis at a minimum launch voltage of 1000 mVpp output swing at beginning of line.
- Combined input equalization + output pre-emphasis performance will be better than individual performance, but less than the sum of the two lengths.
- Input equalization has greatest effect for data-rates higher than 1 Gbps.
- Default setting optimized for driving 10 - 46 in of PCB trace length. Equalizer can be configured for longer reach using serial interface.
- Test setup: Pattern generator --> test backplane --> DUT --> error detector.

Table 2-9. Output Pre-Emphasis Performance Specifications

Symbol	Parameter	Notes	Minimum	Typical	Maximum	Units
DR _{OUT}	Output signal data-rate	—	42	—	3200 (M21250) 1600 (M21251) 540 (M21252)	Mbps
—	Maximum error-free distance at 3.2 Gbps	2, 3, 6	—	—	40	in
—	Maximum error-free distance at 1.6 Gbps	2, 3, 6	—	—	60	in

NOTES:

- Entire table specified at recommended operating conditions – see [Table 2-2](#).
- Performance measured on standard FR4 backplane such as standards provided by TYCO for 10GE XAUI.
- Measured with PCML receiver without input equalization, using PCML output driver at 1200 mVpp output swing at beginning of line.
- Combined input equalization + output pre-emphasis performance will be better than individual performance, but less than the sum of the two lengths.
- Output pre-emphasis has greatest effect for data-rates higher than 1 Gbps.
- Test setup: Pattern generator --> DUT --> test backplane --> error detector.

Table 2-10. Reference Clock Input

Symbol	Parameter	Notes	Minimum	Typical	Maximum	Units
F _{ref}	Input frequency (<i>Refclk_ctrl</i> [3:1] = 000b)	2,3	10	19.44	25	MHz
F _{ref}	Input frequency (<i>Refclk_ctrl</i> [3:1] = 001b)	2,3	20	38.88	50	MHz
F _{ref}	Input frequency (<i>Refclk_ctrl</i> [3:1] = 010b)	2,3	40	77.76	100	MHz
F _{ref}	Input frequency (<i>Refclk_ctrl</i> [3:1] = 011b)	2,3	80	155.52	200	MHz
F _{ref}	Input frequency (<i>Refclk_ctrl</i> [3:1] = 100b)	2	120	250	300	MHz
F _{ref}	Input frequency (<i>Refclk_ctrl</i> [3:1] = 101b)	2,3	160	311.04	400	MHz
F _{ref}	Input frequency (<i>Refclk_ctrl</i> [3:1] = 110b)	2,3	320	622.08	800	MHz
V _{ID}	Input differential voltage (P-P)	4,5	100	—	1600	mV
V _{ICM}	Input common-mode voltage	2,5	250	—	AVdd_I/O	mV
—	Input duty cycle	—	40	50	60	%
—	Frequency stability	2	—	—	100	ppm
R _{IN}	Differential termination	5	—	100	—	Ω
—	Internal pull-down to Vss	—	—	100	—	kΩ
—	Maximum DC input current	—	—	—	15	mA

NOTES:

- Specified at recommended operation conditions – see [Table 2-2](#).
- Used for frequency acquisition.
- Typical values are exact integer ratios for SONET applications.
- Example 1200 mV_{pp} differential = 600 mV_{pp} for each single-ended terminal.
- Input can accept a CMOS single-ended clock on differential P terminal when differential N terminal is decoupled to ground with a large enough capacitor. CMOS input will then see an effective 100Ω load.
- See [Figure 2-3](#) for input termination circuit.

Figure 2-3. Reference Clock Input Internal Circuitry

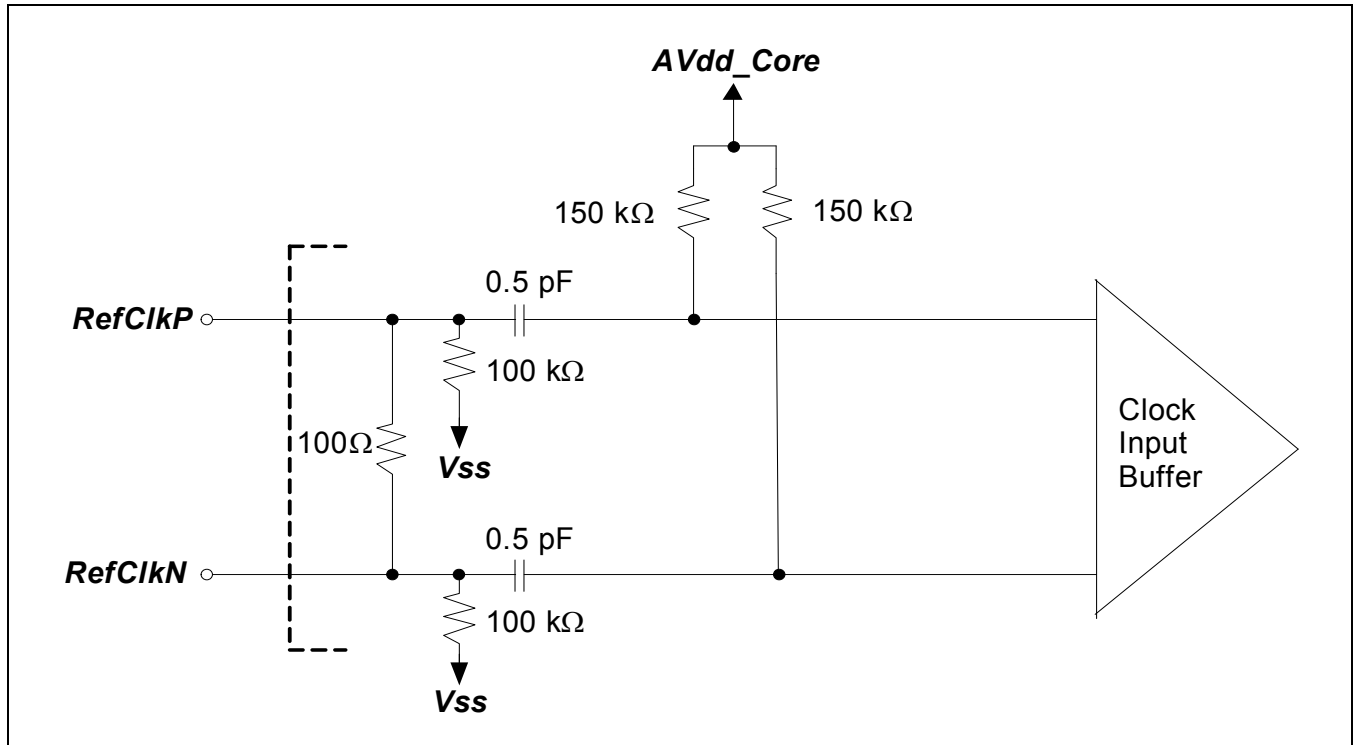

Table 2-11. CDR/RCLK High-Speed Performance (1 of 3)

Symbol	Parameter	Notes	Minimum	Typical	Maximum	Units
DR _{IN}	Input signal data-rate (NRZ data) divider ratio = 1	—	2	—	3.2	Gbps
DR _{IN}	Input signal data-rate (NRZ data) divider ratio = 2	—	1	—	1.6	Gbps
DR _{IN}	Input signal data-rate (NRZ data) divider ratio = 4	—	500	—	800	Mbps
DR _{IN}	Input signal data-rate (NRZ data) divider ratio = 8	—	250	—	400	Mbps
DR _{IN}	Input signal data-rate (NRZ data) divider ratio = 12	—	167	—	267	Mbps
DR _{IN}	Input signal data-rate (NRZ data) divider ratio = 16	—	125	—	200	Mbps
DR _{IN}	Input signal data-rate (NRZ data) divider ratio = 24	—	83	—	133	Mbps
DR _{IN}	Input signal data-rate (NRZ data) divider ratio = 32	—	62.5	—	100	Mbps
DR _{IN}	Input signal data-rate (NRZ data) divider ratio = 48	—	42	—	67	Mbps
J _{TOL}	Jitter tolerance (Figure 2-6)	2	—	0.625	—	UI
J _{TRF}	Jitter transfer (Figure 2-7)	2, 16	—	—	—	—
J _{GEN}	Jitter generation (rms) at STS-N (N = 1, 3, 12, 48)	2, 12	—	4.5	6.5	mUI
J _{GEN}	Jitter generation (pp) at STS-N (N = 1, 3, 12, 48)	2, 12	—	30	55	mUI
F _{LBW}	Default loop bandwidth: divider ratio = 1	3,4,5	—	—	2	MHz
F _{LBW}	Default loop bandwidth: divider ratio = 2	3,4,5	—	—	1	MHz

Table 2-11. CDR/RCLK High-Speed Performance (2 of 3)

Symbol	Parameter	Notes	Minimum	Typical	Maximum	Units
F _{LBW}	Default loop bandwidth: divider ratio = 4	3,4,5	—	—	500	KHz
F _{LBW}	Default loop bandwidth: divider ratio = 8	3,4,5	—	—	250	KHz
F _{LBW}	Default loop bandwidth: divider ratio = 12	3,4,5	—	—	167	KHz
F _{LBW}	Default loop bandwidth: divider ratio = 16	3,4,5	—	—	125	KHz
F _{LBW}	Default loop bandwidth: divider ratio = 24	3,4,5	—	—	83	KHz
F _{LBW}	Default loop bandwidth: divider ratio = 32	3,4,5	—	—	62.5	KHz
F _{LBW}	Default loop bandwidth: divider ratio = 48	3,4,5	—	—	41.6	KHz
R _j	Output data random jitter (pp)	13	—	—	100	mUI
D _j	Output data deterministic jitter (pp)	13	—	—	110	mUI
T _j	Output data total jitter (pp)	13	—	—	210	mUI
J _{rms}	Output data broadband jitter (rms)	14, 15	—	13	40	mUI
J _{pp}	Output data broadband jitter (pp)	14, 15	—	75	230	mUI
T _{SK}	Delay from falling edge of positive clock output to data transition (Figure 2-4)	—	-50	—	50	ps
J _{rms}	Output clock broadband jitter (rms)	14, 15	—	13	40	mUI
J _{pp}	Output clock broadband jitter (pp)	14, 15	—	75	230	mUI
C _{DC}	Output clock duty cycle	—	45	50	55	%
D _{DC}	Output data duty cycle	—	45	50	55	%
T _{LAT}	Latency from input to output (utilizing CDR)	—	—	1.75	2	ns
CH _{SK}	Channel to channel output data skew (utilizing CDR)	—	—	10	65	ps
—	Initialization time	6,7,10	—	2	—	ms
T _{FRA}	Frequency acquisition time	6,8	—	0.4	—	ms

Table 2-11. CDR/RCLK High-Speed Performance (3 of 3)

Symbol	Parameter	Notes	Minimum	Typical	Maximum	Units
T _{PLL}	Phase lock time with 100 ppm delta F	9,11			100	ns
T _{PLL}	Phase lock time with 0 ppm delta F	9,11			50	ns

NOTES:

1. Specified at recommended operating conditions – see [Table 2-2](#).
2. Jitter tolerance, jitter transfer, and jitter generation specified with input equalization and output pre-emphasis disabled, utilizing PRBS 2²³-1, per GR-253 test methodologies.
3. Nominal loop bandwidth for 2.48832 GHz/ DRD.
4. Bandwidth is proportional to frequency.
5. For SONET data-rates, default meets SONET specifications.
6. Assume that reference is within +/-100 ppm of desired data-rate.
7. Time after power up, reset, or data-rate change.
8. Time from application of valid data to lock within +/-20% of lock phase.
9. Defined as when phase settles to within 20% of lock phase.
10. After reset (master or soft), initialization takes place, then frequency acquisition.
11. Based on nominal SONET bandwidth (bandwidth can be increased for lower phase lock time).
12. Jitter generation specified per GR-253, utilizing bandpass filter with passband 12 KHz to 20 MHz for STS-48.
13. R_j, D_j, T_j represent jitter measured to BER of 10⁻¹² per FC-PI-2 specifications.
14. Broadband jitter defined as jitter measured on sampling oscilloscope without the use of filters.
15. Maximum value specified incorporates asynchronous aggressors.
16. Jitter transfer of CDR meets the SONET STS-48 mask if loop bandwidth is set to 80% of nominal by writing *Phadj_ctrl_N[5:4] = 00b*. Jitter transfer at STS-12 (STS-3) exceeds mask by 0.1 dB in frequency range 10 - 25.1 KHz (1.5 - 10 KHz).

2.5 High-Speed Performance Specifications

Figure 2-4. Clock and Data Output Skew Timing

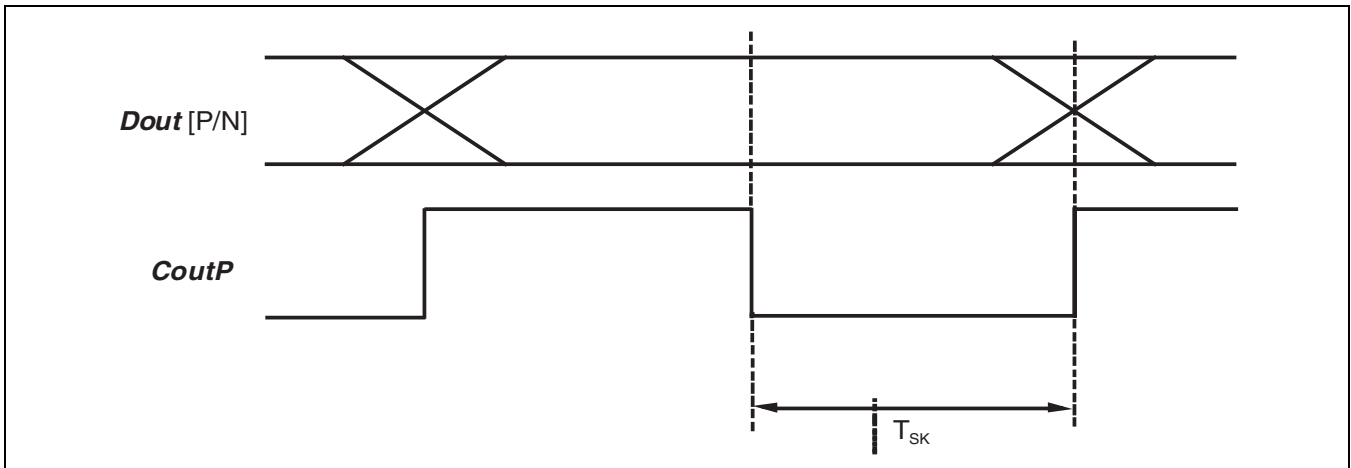

Figure 2-5. SMPTE Jitter Tolerance Specification Mask

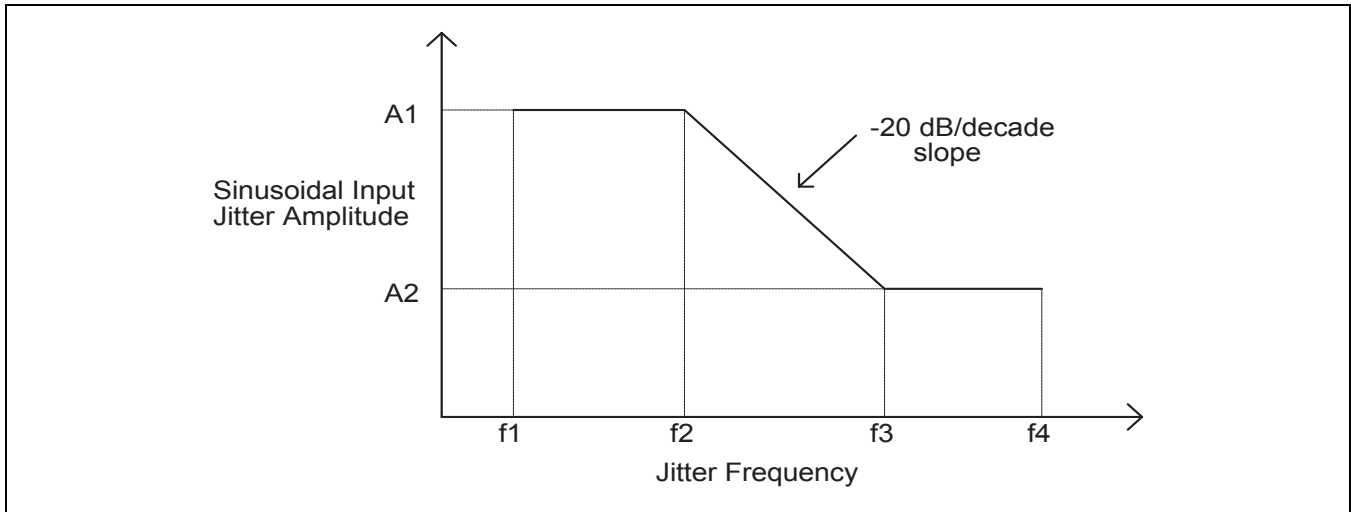

Table 2-12. SMPTE Jitter Tolerance Mask

Jitter Parameter	SMPTE 259M	SMPTE 292M
f1	10 Hz	10 Hz
f2	200 Hz	20 kHz
f3	1 kHz	100 kHz
f4	27 MHz	148.5 MHz
A1	1.0 UI	1.0 UI
A2	0.2 UI	0.2 UI

Figure 2-6. SONET Jitter Tolerance Specification Mask

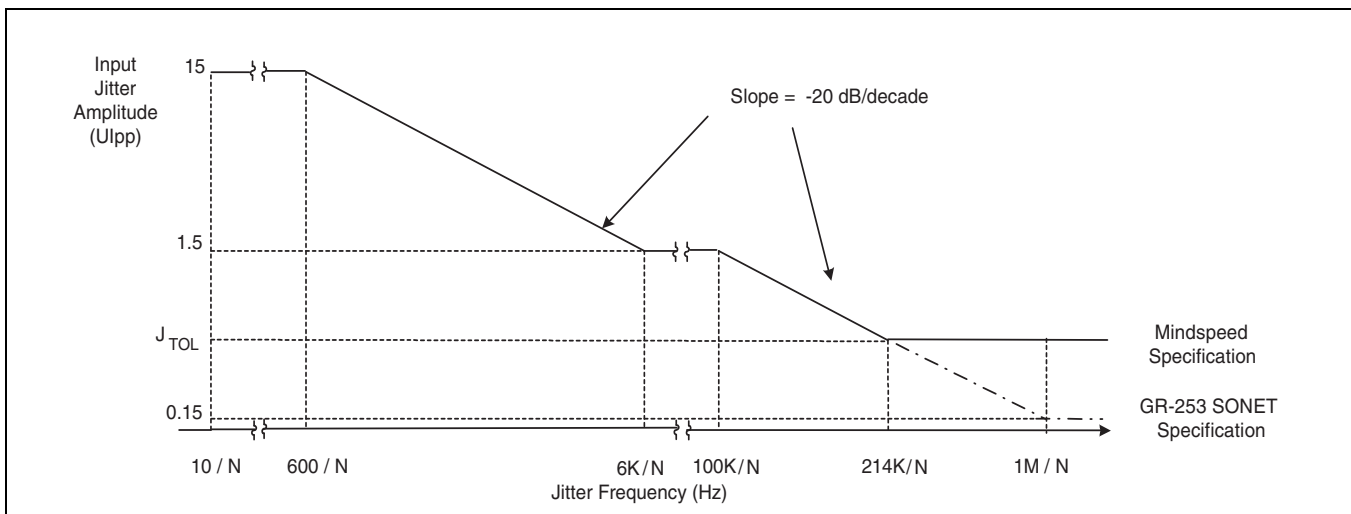

Figure 2-7. SONET/SMPTE Jitter Transfer Specification Mask

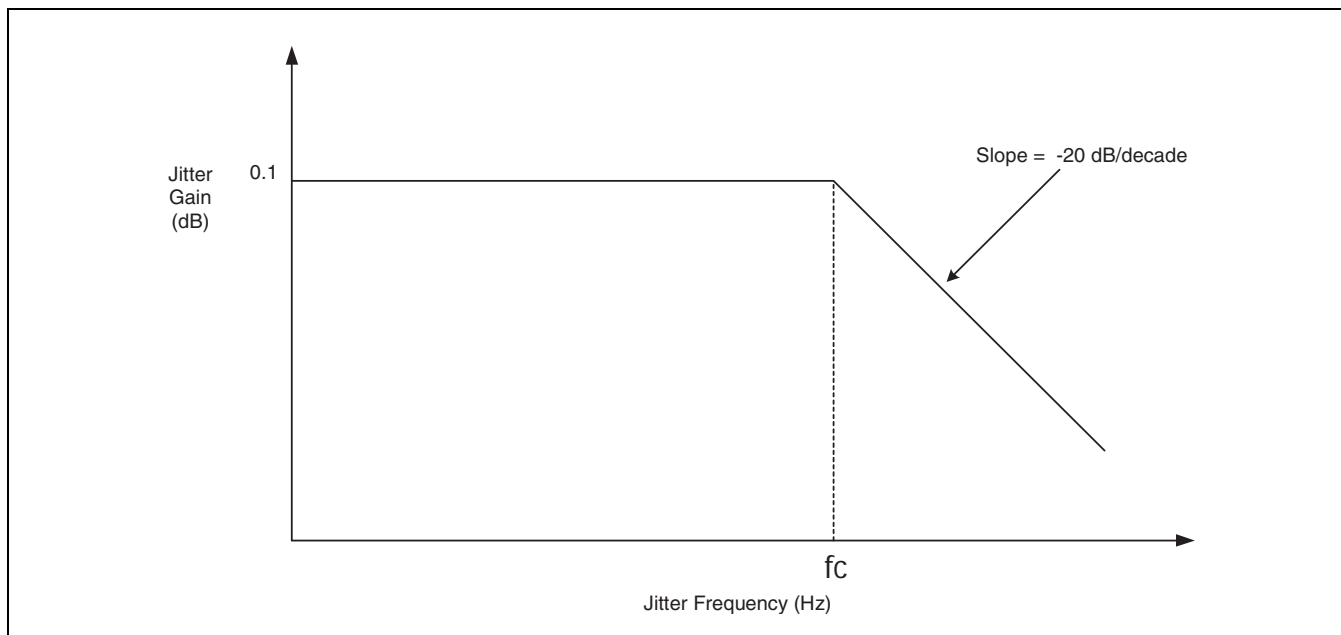

Table 2-13. Loop Bandwidths for Typical Video Data Rates*

Application	Bit Rate (Mbps)	Approximate Loop BW (fc)
3G-SDI	2967/2970	2.38 MHz
HD-SDI	1485/1483.5	1.19 MHz
2xSD-SDI	540	435 kHz
Progressive Scan	360	290 kHz
SD-SDI	270	217 kHz
Legacy Comp Video	177	142 kHz
Legacy Comp Video	143	115 kHz

* See [Table 2-11](#) for jitter transfer at SONET data rates.

Table 2-14. CDR/RCLK Alarm Performance

Symbol	Parameter	Notes	Minimum	Typical	Maximum	Units
DT _{LOA}	xLOA decision time	4, 5	—	26	—	μs
—	xLOA assertion transition density threshold (xLOA = H to L)	5, 6	—	12.5	—	%
—	xLOA de-assertion transition density threshold (xLOA = L to H)	5, 6	—	12.5	—	%
DT _{LOL}	xLOL decision time (measurement time)	2, 3, 4	10	420	3275	μs
WRW	xLOL assertion frequency threshold (xLOL = H to L)	—	±185	±2930	±250000	ppm
NRW	xLOL de-assertion frequency threshold (xLOL = L to H)	—	±120	±1955	±250000	ppm

NOTES:

1. Entire table specified at recommended operating conditions – see [Table 2-2](#).
2. Actual time is set with LOL window. Typical is the default value. Minimum and maximum indicate dynamic range.
3. Assume that reference is +/-100 ppm of operating frequency.
4. Computed for 2.48832 Gbps data-rate. Will scale with data-rate.
5. Fixed values.
6. Specification shown represents deviation from 50% transition density.

2.6 Package Drawings and Surface Mount Assembly Details

The M2125x is assembled in 72-pin 10 mm x 10 mm QFN packages. This is a plastic encapsulated package with a copper leadframe. The QFN is a leadless package with lands on the bottom surface of the package.

The exposed die paddle serves as the IC ground (**Vss**), and the primary means of thermal dissipation. This die paddle should be soldered to the PCB. A cross-section of the QFN package can be found in [Figure 2-8](#).

Figure 2-8. Cross-Section of QFN Package

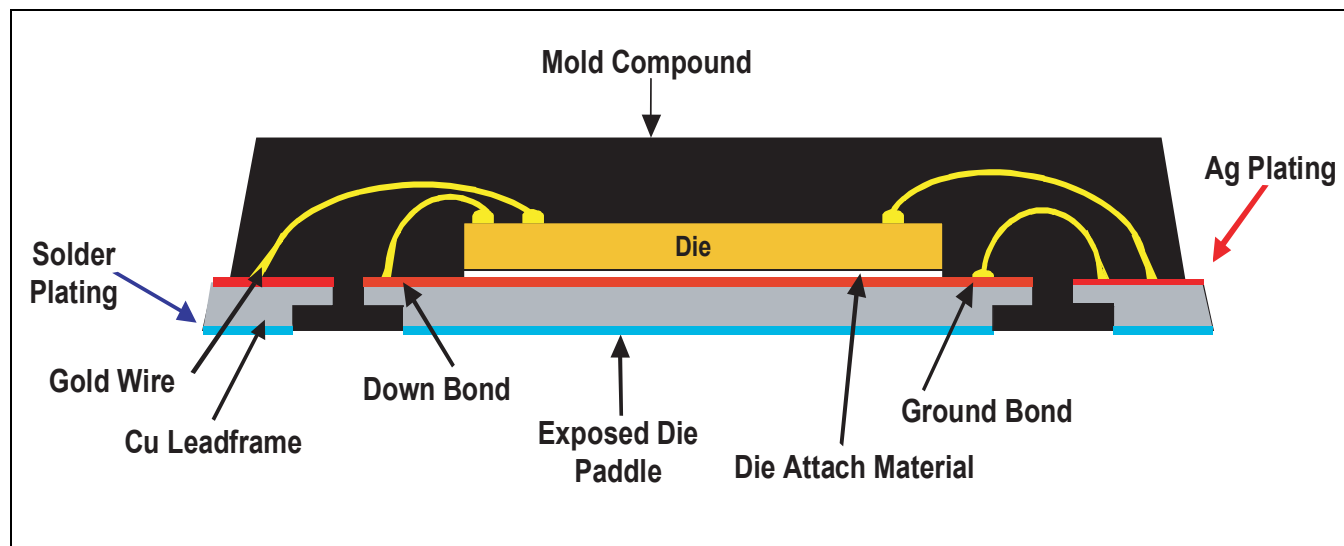

Figure 2-9 and Figure 2-10 shows the package outline drawing for the 10 mm x 10 mm QFN package.

Figure 2-9. Package Drawing (1 of 2)

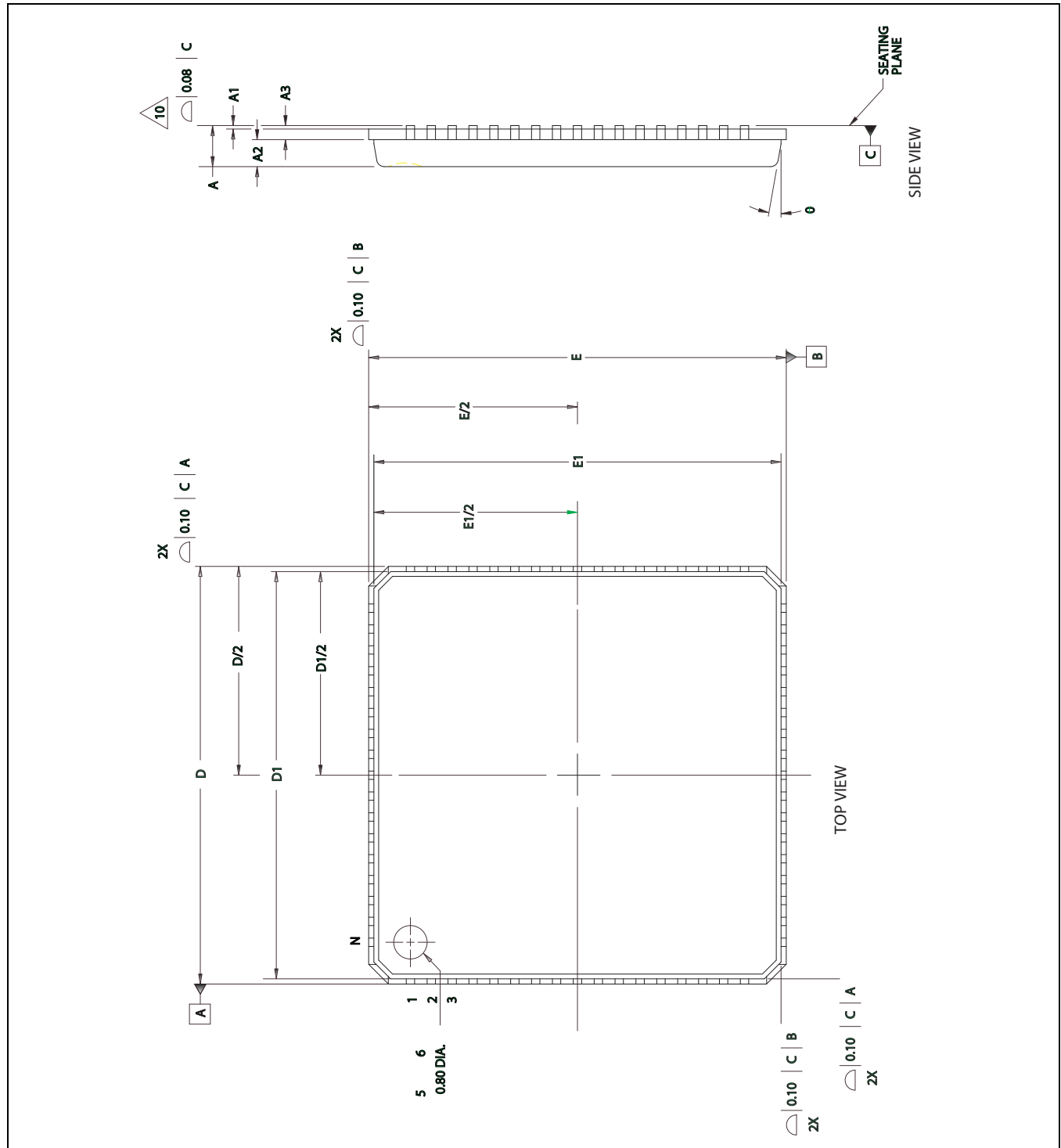
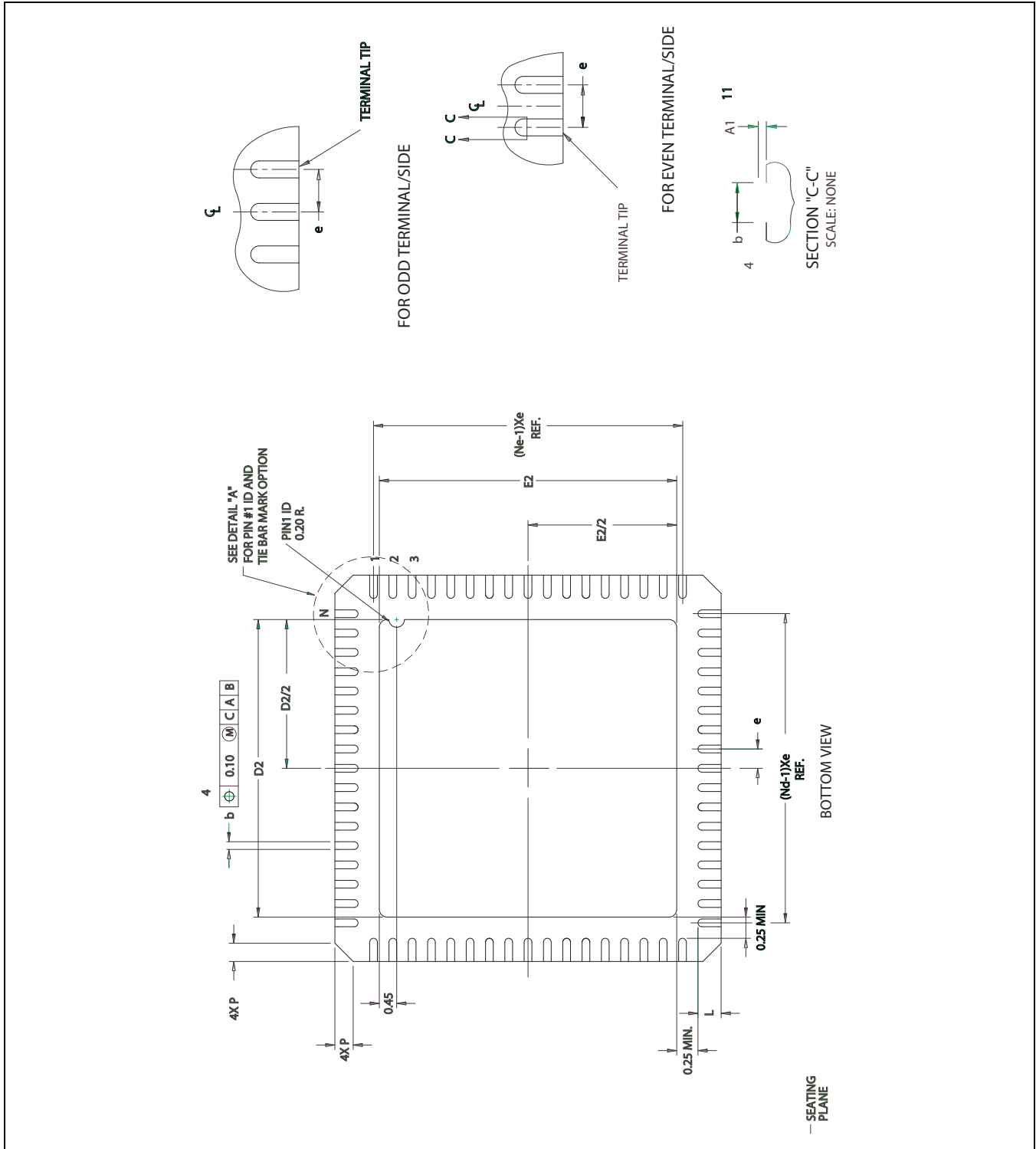
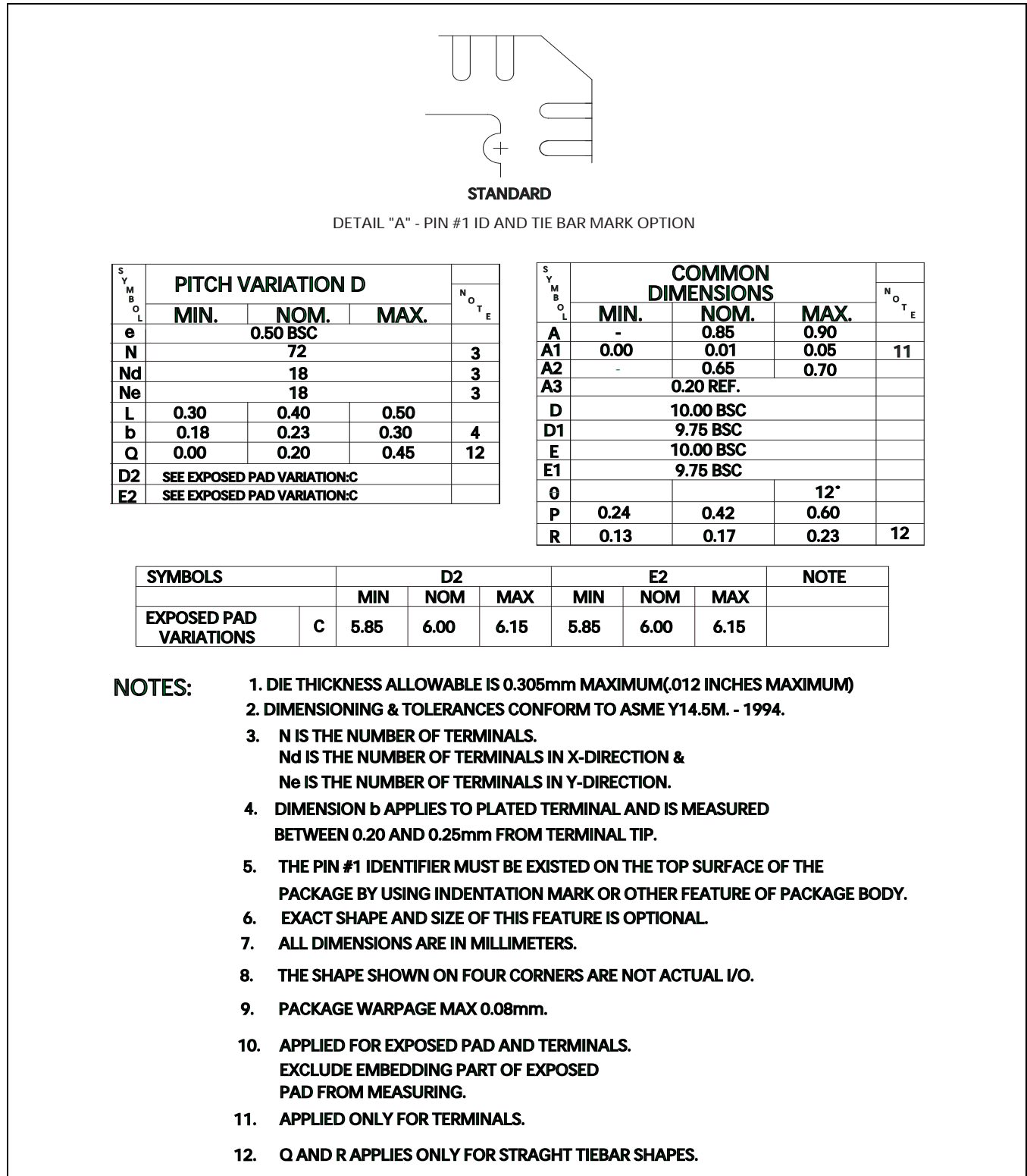

Figure 2-10. Package Drawing (2 of 2)



The relevant dimensions for the 72-pin version of the package can be found in [Figure 2-11](#).

Figure 2-11. 72-Pin Package Dimensions



The M2125x evaluation module (EVM) uses the PCB footprint shown in [Figure 2-12](#).

Figure 2-12. PCB Footprint for 72-Pin 10 mm QFN Package

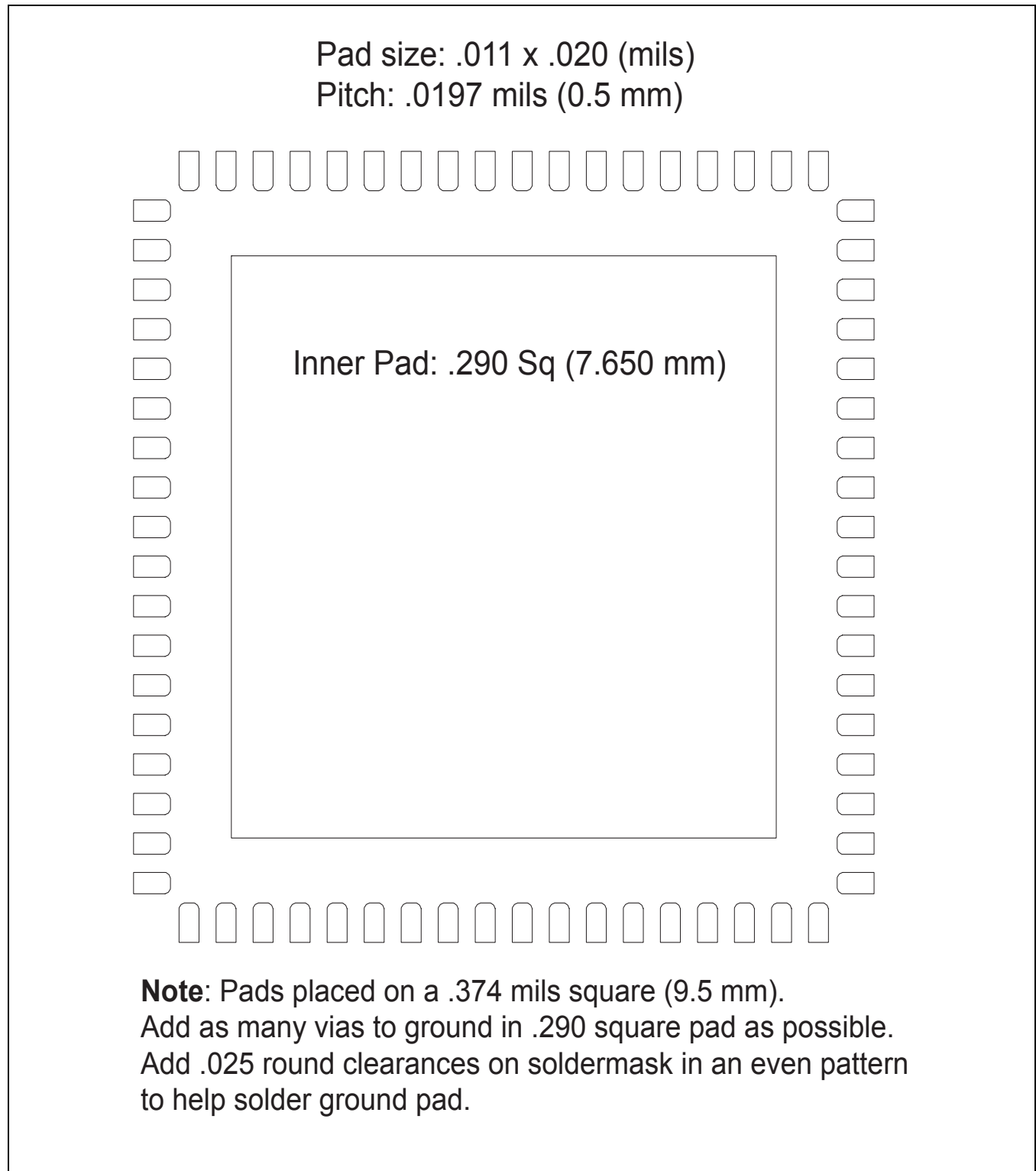

The pad length dimensions should account for component tolerances, PCB tolerances, and placement tolerances. At a minimum, the pad should extend at least 0.1 mm on the outside and 0.05 mm on the inside, as shown in [Figure 2-13](#).

Figure 2-13. PCB Pad Extensions

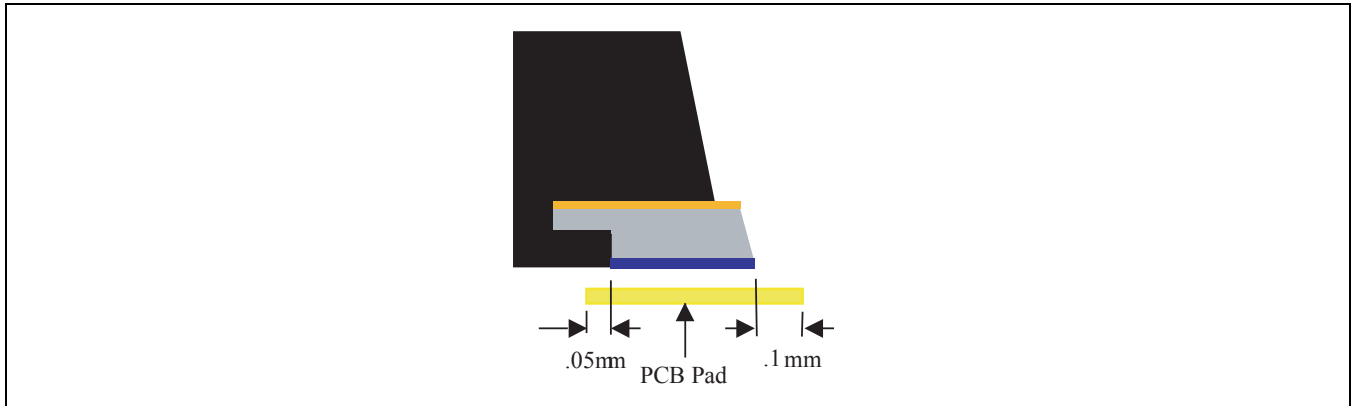

To efficiently dissipate heat from the M2125x, a thermal pad with thermal vias should be used on the PCB. An example of a thermal pad with a 4x4 via array is shown in [Figure 2-14](#). The thermal vias provide a heat conduction path to inner and/or bottom layers of the PCB. The larger the via array, the lower the thermal resistance (θ_{ja}). It is recommended to use thermal vias with 1.0 to 1.2 mm pitch with 0.3 to 0.33 mm via diameter.

Figure 2-14. Recommended Via Array for Thermal Pad

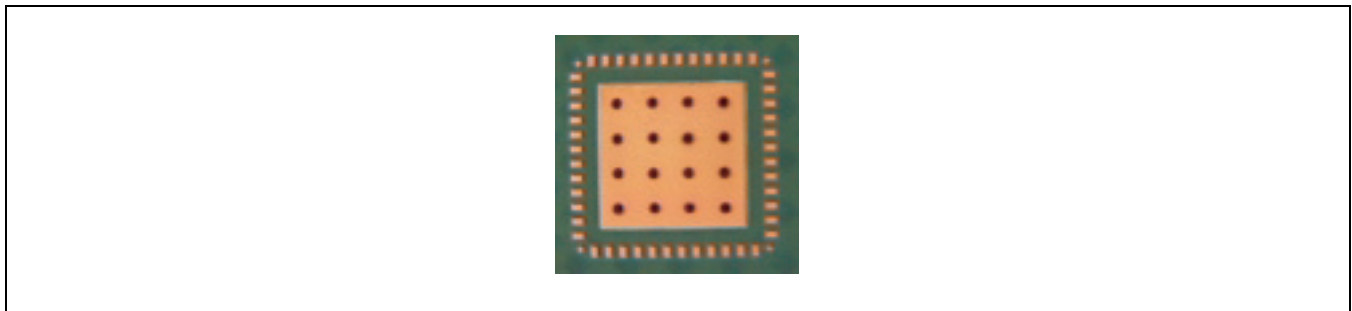

For further details please refer to the relevant application note from package vendor Amkor (see list of references at the end of this document). Much of the material in this section has been adopted from the Amkor SMT application note.

2.7 PCB High-Speed Design and Layout Guidelines

A single power plane for the *AVdd_I/O* and *AVdd_Core* power supplies with bulk capacitors (typically 10 μF) distributed throughout the board will mitigate most power-rail related voltage transients. A bulk capacitor should also be placed where the power enters the board. It is recommended that decoupling capacitors only be routed directly to the power pin if they can be placed within 1/8 of an inch of the pin. Decoupling capacitors should be dispersed around the outside of the device on the top side and underneath the IC on the bottom side of the board. It is recommended that 0.1 μF and 0.01 μF decoupling capacitors be used. All three capacitor values are not required on each pin, but should be dispersed uniformly to filter different frequencies of noise.

A continuous ground plane is the best way to minimize ground impedance. Return currents and power supply transients produce most ground noise during switching. Reducing ground plane impedance minimizes this effect. There is a high frequency decoupling effect from the capacitive effect of power/ground planes and this can be used to help minimize the amount of high frequency decoupling capacitors.

High-speed PCML signals should be routed with 50 Ω equal length traces for P and N signals within each differential pair. Buried strip line is recommended for internal layers while microstrip line is used for signals routed on surface layers. There should be no discontinuity in the ground planes during the path of the signal traces.

Impedance discontinuities occur when a signal passes through vias and travels between layers. It is recommended to minimize the number of vias and layers that the transmit/receive signals travel through in the design. The system PCB should be designed so that high-speed signals pass through a minimal number of vias and remain on a single internal high-speed routing layer.

When vias need to be used, the via design should match the transmission line impedance by observing the following:

- Avoid through-hole vias; they cause stubs by extending the full cross-section of the PCB despite the fact that the layer change requires only a small length via (as in the case of adjacent layers). Use short blind vias.
- Avoid layer changes in general as the characteristic impedance of the transmission line changes as a result.

In general, some rules of thumb for PCB design for high data-rates are:

- PCB trace width for high-speed signals should closely match the SMT component width, so as to prevent stub effects from a sudden change in stripline width. A gradual increase in trace width is recommended as it meets the SMT pad.
- The PCB ground/power planes should be removed from under the I/O pins so as to reduce parasitic capacitance.
- High-speed traces should avoid sharp changes in direction. Using large radii will minimize impedance changes. Avoid bending traces by more than 45 degrees; otherwise, provide a circular bend so as to prevent the trace width from widening at the bend.
- Avoid trace stubs by minimizing components (resistors, capacitors) on the board. For instance, a termination resistor at the input of a receiver will inflict a stub effect at high frequency. Termination resistors integrated on chip will eliminate the stub. Components designed to DC couple to one another avoid the need for coupling capacitors and the inherent stubs created from them.

For high-speed differential signals, the trace lengths of each side of the differential pair should be matched to each other as much as possible. The skew between the P and N signals in a differential pair should be tightly controlled in order for the differential receiver to detect a valid data transition. When matching trace-lengths within a differential pair, care should be taken to avoid introducing large impedance discontinuities. The figures below show two methods of matching the trace-lengths for a differential pair.

Typically, the preferred solution for trace-length matching in differential pairs is to use a serpentine pattern for the shorter signal as shown in [Figure 2-15](#). Using a serpentine pattern for length matching will minimize the differential impedance discontinuity while making both trace-lengths equal.

Figure 2-15. Trace-Length Matching Using Serpentine Pattern

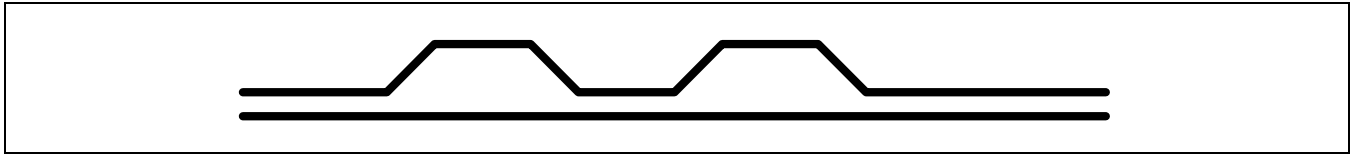
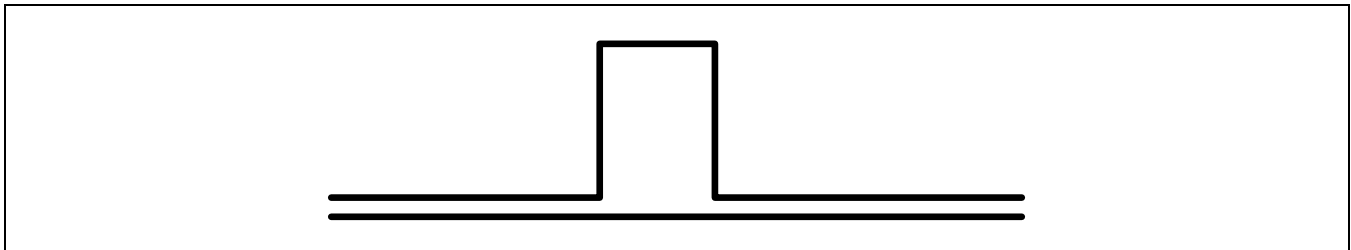

Figure 2-16. Loop Length Matching for Differential Traces



The loop length matching method shown in [Figure 2-16](#) will match the trace lengths of a differential pair, but will create a large impedance discontinuity in the transmission line, which could result in higher jitter on the signal and/or a greater sensitivity to noise for the differential pair.

When using capacitors to AC-couple the input, care should be taken to minimize the pattern-dependant jitter (PD_J) associated with the low-frequency cutoff of the coupling network. When NRZ data containing long strings of 1s or 0s is applied to a high-pass filter, a voltage droop occurs. This voltage droop causes PD_J in much the same fashion as inter-symbol interference (ISI) is generated from dispersion effects of long trace-lengths in backplane material.

If needed, use 0.1 μ F capacitors to AC-couple the high-speed output signals and the reference clock inputs. The high-speed data input signals can be DC-coupled.

On the Evaluation Module (EVM), we have tied **DVdd_I/O** and **AVdd_I/O** together to minimize the number of power supply jacks. They are kept separate on-chip to give the flexibility to the system designers to supply a different voltage level for each. For instance, an FPGA can be used to supply power to **DVdd_I/O**, while a lower voltage can be used to power **AVdd_I/O** to minimize power dissipation. On the EVM, we have also tied **DVdd_Core** and **AVdd_Core** together to minimize the number of power supply jacks. They are kept separate on-chip to provide more isolation, however, if the system board plane is properly decoupled, they can be tied together.

No inductive filtering on the system board is necessary between different power supplies of the IC. It is up to the system designer to determine if this needs to be considered for supplies that are coming from other parts of the system board (such as switching regulators or ASICs).

An inductor should not be used at the **VddT** pins. These pins were made available to create a low AC impedance, such that the 50 Ω on-chip termination impedances see a common AC ground. This assures both common-mode and differential termination. Note that a low AC impedance can also be created by tying the **VddT** pins to the **AVdd_Core** plane, thus saving on the number of external capacitors. **VddT** is not a supply plane on-chip, it is simply the point to which the 50 Ω input impedances are tied.

Power planes should be decoupled to ground planes using thin dielectric layers, to increase capacitance (preferably 2-4 mils). Reference ground layers should be used on both sides of inner layer routing planes, with controlled impedance. The total board thickness should meet the standard drill holes to board thickness ratio of 1:12 or 1:14.

Use 1/2 ounce copper clad on all layers, which is approximately 0.7 mils. Avoid placing solder mask and silk-screen on top of transmission lines; solder mask will add 1 - 2 Ω to the overall impedance of the transmission line. Dielectric

core material should be used wherever possible, as it will maintain its thickness and geometry during processing, better than pliable prepreg.

The microwave ground should follow the transmission line from end to end, or from signal input to output. It is best to designate layers as dedicated microwave/circuit ground planes, and properly isolate them from other ground planes by providing adequate distance. All microwave ground planes should be tied together.

Uncoupled microstrip transmission lines should be placed at a distance from each other of at least three times the transmission line width. Coupled microstrip transmission lines, such as differential signal pairs, must be placed close to each other and maintain the same separation distance throughout the board (separation distance of at most twice the trace-width). For buried stripline transmission lines, it is good design practice to maintain equal distance between the conductor and the ground plane on both sides.

During PCB manufacturing, over- and under-etching of traces used for transmission lines results in impedance discontinuities. Use of wide traces for transmission lines will reduce the impact of etching issues. Wide traces also help compensate for skin-effect losses in transmission lines. It should be noted, however, that the wider the traces in a differential pair, the thicker the underlying dielectric layer needs to be.

Surface mount connectors are preferred over through-mount connectors. Connectors should be selected that have controlled characteristic impedances that match the characteristic impedances of the transmission lines.

2.8 Auto Rate Detect (ARD) for HD/SD-SDI Digital Video Rates

For many video applications, CDR/reclockers are required to auto rate detect (ARD) the incoming data rate. Mindspeed has developed a reference design for an ARD implementation. The reference design includes binary files for the ARD software and a hardware reference design based on the ATMEL AT89C51Rx2 series of micro controllers. The ARD automatically configures the device for nine possible fixed data rates of 143, 177, 270, 360, 540, 1483.5, 1485, 2967, or 2970 Mbps for the M21250. If desired, customers can expand the ARD code to include operation at other data rates.

Please refer to the M2125X and M2126X ARD software description documents for details on Mindspeed's implementation of Auto Rate Detect for this device.



3.0 Registers

Table 3-1. Register Table Summary

Addr	Register Name	d7: MSB	d6	d5	d4	d3	d2	d1	d0: LSB
Common Registers									
00h	<i>Globctrl</i>	powerup	MSPD Int	MSPD Int	MSPD Int	MSPD Int	MSPD Int	reserved	clear_alm
04h	<i>Refclk_ctrl</i>	reserved	reserved	reserved	reserved	ref_divr[2]	ref_divr[1]	ref_divr[0]	MSPD int
05h	<i>Mastreset</i>	rst	rst	rst	rst	rst	rst	rst	rst
06h	<i>Chipcode</i>	chipcode[7]	chipcode[6]	chipcode[5]	chipcode[4]	chipcode[3]	chipcode[2]	chipcode[1]	chipcode[0]
07h	<i>Revcode</i>	revcode[7]	revcode[6]	revcode[5]	revcode[4]	revcode[3]	revcode[2]	revcode[1]	revcode[0]
10h	<i>BISTrx_chsel</i>					reserved	chan[2]	chan[1]	chan[0]
11h	<i>BISTrx_ctrl</i>	MSPD Int	rx_ctrlr	rx_patt[3]	rx_patt[2]	rx_patt[1]	rx_patt[0]	en_rx	rx_rst
12h	<i>BISTrx_error</i>		err[6]	err[5]	err[4]	err[3]	err[2]	err[1]	err[0]
14h	<i>BISTrx_chsel</i>	reserved	reserved	reserved	reserved	reserved	reserved	tx_chan_1	tx_chan_0
15h	<i>BISTrx_ctrl</i>	err_insert	rx2txclk	tx_patt[3]	tx_patt[2]	tx_patt[1]	tx_patt[0]	en_tx	tx_rst
17h	<i>BISTrx_LOLctrl</i>	tacq_LOL[2]	tacq_LOL[1]	tacq_LOL[0]	narwin_LOL[3]	narwin_LOL[2]	narwin_LOL[1]	narwin_LOL[0]	widwin_LOL[0]
18h	<i>BISTrx_PLL_ctrlA</i>	softreset	MSPD Int	reserved	MSPD Int	reserved	MSPD Int	reserved	MSPD Int
19h	<i>BISTrx_PLL_ctrlB</i>	PLLmode[1]	PLLmode[0]	MSPD Int	MSPD Int	data_rate[3]	data_rate[2]	data_rate[1]	data_rate[0]
1Ah	<i>BISTrx_PLL_ctrlC</i>	VCO_divr[7]	VCO_divr[6]	VCO_divr[5]	VCO_divr[4]	VCO_divr[3]	VCO_divr[2]	VCO_divr[1]	VCO_divr[0]
1Bh	<i>BIST_pattern0</i>					pattern[19]	pattern[18]	pattern[17]	pattern[16]
1Ch	<i>BIST_pattern1</i>	pattern[15]	pattern[14]	pattern[13]	pattern[12]	pattern[11]	pattern[10]	pattern[9]	pattern[8]
1Dh	<i>BIST_pattern2</i>	pattern[7]	pattern[6]	pattern[5]	pattern[4]	pattern[3]	pattern[2]	pattern[1]	pattern[0]
1Fh	<i>BISTrx_alarm</i>	tx_LOL	reserved	reserved	MSPD Int	MSPD Int	MSPD Int	MSPD Int	MSPD Int
20h	<i>Temp_mon</i>					reserved	reserved	en_temp_mon	strobe_temp
21h	<i>Temp_value</i>					temp[3]	temp[2]	temp[1]	temp[0]
30h	<i>Alarm_LOL</i>	MSPD Int	MSPD Int	MSPD Int	MSPD Int	LOL_3	LOL_2	LOL_1	LOL_0
31h	<i>Alarm_LOA</i>	MSPD Int	MSPD Int	MSPD Int	MSPD Int	LOA_3	LOA_2	LOA_1	LOA_0
32h	<i>alarm_trim</i>	reserved	reserved	reserved	reserved	trim_alarm_3	trim_alarm_2	trim_alarm_1	trim_alarm_0
Per channel registers (N=CDR/RCLK#, M=N+4)1									
M0h	<i>cdr_ctrlA_N</i>	softreset	force_filter_rst	inh_force	lol_force	autoinh_en	freqwin_en	los_en	trim_en
M1h	<i>cdr_ctrlB_N</i>	CDRmode[1]	CDRmode[0]	test_1010pat	reserved	data_rate[3]	data_rate[2]	data_rate[1]	data_rate[0]
M2h	<i>RCLK_ctrlC_N</i>	VCO_divr[7]	VCO_divr[6]	VCO_divr[5]	VCO_divr[4]	VCO_divr[3]	VCO_divr[2]	VCO_divr[1]	VCO_divr[0]
M3h	<i>Out_ctrl_N</i>	outlv[1]	outlv[0]	reserved	reserved	data_pol_flip	dataout_en	clkout_en	clk_pol_flip
M4h	<i>Preemp_ctrl_N</i>	reserved	MSPD Int	MSPD Int	MSPD Int	MSPD Int	preemph[2]	preemph[1]	preemph[0]
M5h	<i>Ineq_ctrl_N</i>	reserved	MSPD Int	MSPD Int	en_DCservo	MSPD Int	in_eq[2]	in_eq[1]	in_eq[0]
M6h	<i>Phadj_ctrl_N</i>	i_trim[1]	i_trim[0]	r_sel[1]	r_sel[0]	phase_adj[3]	phase_adj[2]	phase_adj[1]	phase_adj[0]
M9h	<i>LOL_ctrl_N</i>	tacq_LOL[2]	tacq_LOL[1]	tacq_LOL[0]	narwin_LOL[3]	narwin_LOL[2]	narwin_LOL[1]	narwin_LOL[0]	widwin_LOL[0]
MAh	<i>trim_force_N</i>	force_FDAdiv	en_LOT	force_trimmsb	trim_force[4]	trim_force[3]	trim_force[2]	trim_force[1]	trim_force[0]
MBh	<i>trim_value_N</i>	reserved	reserved	reserved	trim_val[4]	trim_val[3]	trim_val[2]	trim_val[1]	trim_val[0]
Notes:									
1. N=0h for CDR/RCLK 0, N=1h for CDR/RCLK 1, ..., N=3h for CDR/RCLK 3.									
2. M=4h for CDR/RCLK 0, M=5h for CDR/RCLK 1, ..., M=7h for CDR/RCLK 3. For example CDR/RCLK 0 starts at address 40h, CDR/RCLK 1 at 50h, CDR/RCLK 2 at 60h, CDR/RCLK 3 at 70h.									

3.1 Global Control Registers

Nomenclature:

1. Reserved bits: bits that exist and reserved for future use by Mindspeed.
2. Bits not defined and not reserved do not exist.
3. Do not write to reserved or undefined bits – operation not guaranteed.
4. MSPD internal: defines an internal function. Must always write the default value to MSPD internal bits. When in doubt, read back default value after reset.

3.1.1 00h:Global Control

Table 3-2. Global Control (Globctrl: Address 00h)

Bits	Type	Default	Label	Description
7	R/W	1b	powerup	Powers up the IC by enabling the current references 1b: Power up the IC (chip powerup, default) 0b: Power down the IC
6:2	R/W	00000b	MSPD internal	N/A (00000 default)
1	R/W	0b	Reserved	N/A (0 default)
0	R/W	0b	clear_alm	Clears the <i>Alarm_LOA</i> , <i>Alarm_LOL</i> alarm registers 1b: Clear alarms 0b: Normal operation - latch alarm bits (default) Note: Upon writing a 1b to this bit, it clears the registers, and user needs to write a 0b to enable the normal state.

3.1.2 04h: External Reference Frequency Divider Control (RFD)

Table 3-3. External Reference Frequency Divider Control (RFD) (Refclk_ctrl: Address 04h)

Bits	Type	Default	Label	Description
7:4	R/W	0b	Reserved	N/A (0 default)
3:1	R/W	000b	ref_divr	Sets the divider ratio to scale down <i>RefClk</i> to the internal rate for FRA/LOA 000b: RFD = 1 (default) 001b: RFD = 2 010b: RFD = 4 011b: RFD = 8 100b: RFD = 12 101b: RFD = 16 110b: RFD = 32
0	R/W	0b	MSPD internal	N/A (0 default)

3.1.3 05h:Master IC Reset

Table 3-4. Master IC Reset (Mastreset: Address 05h)

Bits	Type	Default	Label	Description
7:0	R/W	0b	rst	Same feature as hardware xRST . Resets the entire IC AAh: Reset upon write to this register with AAh 00h: Normal operation [default] Note: All other values are ignored.

3.1.4 06h:IC Electronic Identification

Table 3-5. IC Electronic ID (Chipcode: Address 06h)

Bits	Type	Default	Label	Description
7:0	R	16h	chipcode	This register contains the identification of this IC.

3.1.5 07h:IC Revision Code

Table 3-6. IC Revision Code (Revcode: Address 07h)

Bits	Type	Default	Label	Description
7:0	R	23h	revcode	This register contains the revision of the IC.

3.1.6 10h:Built In Self-Test (BIST) Receiver Channel Select

Table 3-7. Built In Self-Test (BIST) Receiver Channel Select (BISTrx_chsel: Address 10h)

Bits	Type	Default	Label	Description
7:3	R/W	00000b	Reserved	N/A (00000 default)
2:0	R/W	000b	chan	Selects which CDR/RCLK to route into the BIST receiver (active when <i>BISTrx_ctrl</i> [1]=1) 000b: Output CDR/RCLK 0 to BIST (default) 001b: Output CDR/RCLK 1 to BIST 010b: Output CDR/RCLK 2 to BIST 011b: Output CDR/RCLK 3 to BIST

3.1.7 11h:Built In Self-Test (BIST) Receiver Main Control Register

Table 3-8. Built In Self-Test (BIST) Receiver Main Control Register (BISTrx_ctrl: Address 11h)

Bits	Type	Default	Label	Description
7	R/W	0b	MSPD internal	N/A (0 default)
6	R/W	0b	rx_ctrclr	Clear the BIST Rx error count register, <i>BISTrx_error</i> (active when <i>BISTrx_ctrl</i> [1] = 1) 0b: Normal operation (default) 1b: Clear register
5:2	R/W	0000b	rx_patt	Selects the BIST Rx test pattern (active when <i>BISTrx_ctrl</i> [1] = 1) 0000b: PRBS 2 ⁷ -1 (default) 0001b: PRBS 2 ¹⁵ -1 0010b: PRBS 2 ²³ -1 0011b: PRBS 2 ³¹ -1 0100b: Fibre channel CJTPAT 0101b: Fibre channel CRPAT 0110b: 8b/10b countdown pattern 0111b: 16 bit user programmable pattern 1000b: 20 bit user programmable pattern
1	R/W	0b	en_rx	Powers up the BIST Rx 0b: Power down (default) 1b: Power up and enable
0	R/W	1b	rx_rst	Resets the BIST Rx (recommended after powerup/enable, active when <i>BISTrx_ctrl</i> [1] = 1) 0b: Normal BIST Rx operation 1b: Reset of BIST Rx (default)

3.1.8 12h:Built In Self-Test (BIST) Receiver Bit Error Counter

Table 3-9. Built In Self-Test (BIST) Receiver Bit Error Counter (BISTrx_error: Address 12h)

Bits	Type	Default	Label	Description
7:0	R/W	00h	err	Bit error count (active when <i>BISTrx_ctrl</i> [1] = 1) This register is set to 00h upon reset, and is incremented for every bit error the BIST Rx receives, up to FFh. At FFh, the register will stay at this level until cleared.

3.1.9 14h:Built In Self-Test (BIST) Transmitter Channel Select

Table 3-10. Built In Self-Test (BIST) Transmitter Channel Select (BISTtx_chsel: Address 14h)

Bits	Type	Default	Label	Description
7:4	R/W	0000b	Reserved	N/A (0000 default)
3:2	R/W	00b	MSPD internal	N/A (00 default)
1:0	R/W	00b	tx_chan	Selects which output channel the BIST Tx outputs the test pattern on (active when <i>BISTtx_ctrl</i> [1] = 1) Bit map: 1b = BIST Tx on, 0b = BIST Tx off (default) [1]: Output channel 1 [0]: Output channel 0 Note: Registers are set up to allow for multicasting BIST Tx output.

3.1.10 15h:Built In Self-Test (BIST) Transmitter Main Control Register

Table 3-11. Built In Self-Test (BIST) Transmitter Main Control Register (BISTtx_ctrl: Address 15h)

Bits	Type	Default	Label	Description
7	R/W	0b	err_insert	Inserts a single bit error into the PRBS Tx 1b: Insert error 0b: Normal operation (default) Note: Setting the register high allows one error to be inserted into the data stream. To insert another error, the user needs to clear, then set this register bit.
6	R/W	0b	rx2txclk	Selects the source of the clock for the BIST Tx PLL (active when <i>BISTtx_ctrl</i> [1] = 1) 0b: External reference frequency (default) 1b: Recovered clock from BIST Rx Note: For the recovered clock option, the BIST Rx must be enabled with <i>BISTrx_ctrl</i> [1] = 1, and use the recovered clock from the same CDR/RCLK selected by BIST Rx. This option only works for the M21250 at data rates above 2.0 Gbps.
5:2	R/W	0000b	tx_patt	Selects the BIST Tx test pattern (active when <i>BISTtx_ctrl</i> [1] = 1) 0000b: PRBS 2 ⁷ -1 (default) 0001b: PRBS 2 ¹⁵ -1 0010b: PRBS 2 ²³ -1 0011b: PRBS 2 ³¹ -1 0100b: Fibre channel CJTPAT 0101b: Fibre channel CRPAT 0110b: 8b/10b countdown pattern 0111b: 16 bit user programmable pattern 1000b: 20 bit user programmable pattern
1	R/W	0b	en_tx	Powers up the BIST Tx and PLL 0b: Power down (default) 1b: Power up and enable
0	R/W	1b	tx_rst	Resets the BIST Tx (recommended after powerup/enable; active when <i>BISTtx_ctrl</i> [1] = 1) 0b: Normal BIST Tx operation 1b: Reset of BIST Tx (default)

3.1.11 17h:Built In Self-Test (BIST) Transmitter PLL Loss of Lock Register

Table 3-12. Built In Self-Test (BIST) Transmitter PLL Loss of Lock Register (BISTtx_LOLctrl: Address 17h) (1 of 2)

Bits	Type	Default	Label	Description																																		
7:5	R/W	101b	tacq_LOL	<p>Sets the value for the LOL reference window</p> <table border="1"> <thead> <tr> <th>Code</th> <th>Value</th> </tr> </thead> <tbody> <tr><td>000b</td><td>128</td></tr> <tr><td>001b</td><td>256</td></tr> <tr><td>010b</td><td>512</td></tr> <tr><td>011b</td><td>1024</td></tr> <tr><td>100b</td><td>2048</td></tr> <tr><td>101b</td><td>4096 (default)</td></tr> <tr><td>110b</td><td>8192</td></tr> <tr><td>111b</td><td>16384</td></tr> </tbody> </table>	Code	Value	000b	128	001b	256	010b	512	011b	1024	100b	2048	101b	4096 (default)	110b	8192	111b	16384																
Code	Value																																					
000b	128																																					
001b	256																																					
010b	512																																					
011b	1024																																					
100b	2048																																					
101b	4096 (default)																																					
110b	8192																																					
111b	16384																																					
4:1	R/W	0100b	narwin_LOL	<p>Sets the narrow LOL window for the LOL = H to LOL = L transition (transition to in lock threshold)</p> <table border="1"> <thead> <tr> <th>Code</th> <th>Value</th> </tr> </thead> <tbody> <tr><td>0000b</td><td>2</td></tr> <tr><td>0001b</td><td>3</td></tr> <tr><td>0010b</td><td>4</td></tr> <tr><td>0011b</td><td>6</td></tr> <tr><td>0100b</td><td>8 (default)</td></tr> <tr><td>0101b</td><td>12</td></tr> <tr><td>0110b</td><td>16</td></tr> <tr><td>0111b</td><td>24</td></tr> <tr><td>1000b</td><td>9</td></tr> <tr><td>1001b</td><td>10</td></tr> <tr><td>1010b</td><td>11</td></tr> <tr><td>1011b</td><td>12</td></tr> <tr><td>1100b</td><td>13</td></tr> <tr><td>1101b</td><td>14</td></tr> <tr><td>1110b</td><td>15</td></tr> <tr><td>1111b</td><td>32</td></tr> </tbody> </table>	Code	Value	0000b	2	0001b	3	0010b	4	0011b	6	0100b	8 (default)	0101b	12	0110b	16	0111b	24	1000b	9	1001b	10	1010b	11	1011b	12	1100b	13	1101b	14	1110b	15	1111b	32
Code	Value																																					
0000b	2																																					
0001b	3																																					
0010b	4																																					
0011b	6																																					
0100b	8 (default)																																					
0101b	12																																					
0110b	16																																					
0111b	24																																					
1000b	9																																					
1001b	10																																					
1010b	11																																					
1011b	12																																					
1100b	13																																					
1101b	14																																					
1110b	15																																					
1111b	32																																					

Table 3-12. Built In Self-Test (BIST) Transmitter PLL Loss of Lock Register (BISTtx_LOLctrl: Address 17h) (2 of 2)

Bits	Type	Default	Label	Description																																																			
0	R/W	0b	widwin_LOL	<p>Sets the wide LOL window for the LOL = L to LOL = H transition (transition to out of lock threshold)</p> <table border="1"> <thead> <tr> <th>Narrow Code</th> <th>Wide Code 0b (default)</th> <th>Wide Code 1b</th> </tr> </thead> <tbody> <tr><td>0000b</td><td>3</td><td>8</td></tr> <tr><td>0001b</td><td>4</td><td>12</td></tr> <tr><td>0010b</td><td>6</td><td>16</td></tr> <tr><td>0011b</td><td>8</td><td>24</td></tr> <tr><td>0100b</td><td>12</td><td>32</td></tr> <tr><td>0101b</td><td>16</td><td>32</td></tr> <tr><td>0110b</td><td>24</td><td>32</td></tr> <tr><td>0111b</td><td>32</td><td>32</td></tr> <tr><td>1000b</td><td>12</td><td>32</td></tr> <tr><td>1001b</td><td>12</td><td>32</td></tr> <tr><td>1010b</td><td>12</td><td>32</td></tr> <tr><td>1011b</td><td>16</td><td>32</td></tr> <tr><td>1100b</td><td>16</td><td>32</td></tr> <tr><td>1101b</td><td>16</td><td>32</td></tr> <tr><td>1110b</td><td>16</td><td>32</td></tr> <tr><td>1111b</td><td>32</td><td>32</td></tr> </tbody> </table>	Narrow Code	Wide Code 0b (default)	Wide Code 1b	0000b	3	8	0001b	4	12	0010b	6	16	0011b	8	24	0100b	12	32	0101b	16	32	0110b	24	32	0111b	32	32	1000b	12	32	1001b	12	32	1010b	12	32	1011b	16	32	1100b	16	32	1101b	16	32	1110b	16	32	1111b	32	32
Narrow Code	Wide Code 0b (default)	Wide Code 1b																																																					
0000b	3	8																																																					
0001b	4	12																																																					
0010b	6	16																																																					
0011b	8	24																																																					
0100b	12	32																																																					
0101b	16	32																																																					
0110b	24	32																																																					
0111b	32	32																																																					
1000b	12	32																																																					
1001b	12	32																																																					
1010b	12	32																																																					
1011b	16	32																																																					
1100b	16	32																																																					
1101b	16	32																																																					
1110b	16	32																																																					
1111b	32	32																																																					

3.1.12 18h:Built In Self-Test (BIST) Transmitter PLL Control Register A

Table 3-13. Built In Self-Test (BIST) Transmitter PLL Control Register A (BISTtx_PLL_ctrlA: Address 18h)

Bits	Type	Default	Label	Description
7	R/W	0b	softreset	Resets the BIST transmitter PLL (assuming <i>BISTtx_ctrl</i> [1] = 1b) 0b: Normal operation 1b: Reset PLL only
6	R/W	0b	MSPD internal	N/A (0 default)
5	R/W	0b	Reserved	N/A (0 default)
4	R/W	0b	MSPD internal	N/A (0 default)
3	R/W	0b	Reserved	N/A (0 default)
2	R/W	1b	MSPD internal	N/A (1 default)
1	R/W	0b	Reserved	N/A (0 default)
0	R/W	1b	MSPD internal	N/A (1 default)

3.1.13 19h:Built In Self-Test (BIST) Transmitter PLL Control Register B

Table 3-14. Built In Self-Test (BIST) Transmitter PLL Control Register B (BISTtx_PLL_ctrlB: Address 19h)

Bits	Type	Default	Label	Description
7:6	R/W	00b	PLLmode	Determines state of the PLL. Must be enabled in addition to the BIST Tx (BISTtx_ctrl[1] = 1b) 00b: Channel active, PLL powered up (default) 11b: Channel active, PLL powered down
5:4	R/W	00b	MSPD internal	N/A (00 default)
3:0	R/W	0000b	data_rate	Data-rate divider (DRD): this divides down the VCO frequency to the desired data-rate 0000b: DRD = 1 (default) 0001b: DRD = 2 0010b: DRD = 4 0011b: DRD = 8 0100b: DRD = 12 0101b: DRD = 16 0110b: DRD = 24 0111b: DRD = 32 1000b: DRD = 48 Note: Please consult $F_{vco,max}$ and $F_{vco,min}$ to determine the frequency range of each DRD ratio.

3.1.14 1Ah:Built In Self-Test (BIST) Transmitter PLL Control Register C

Table 3-15. Built In Self-Test (BIST) Transmitter PLL Control Register C (BISTtx_PLL_ctrlC: Address 1Ah)

Bits	Type	Default	Label	Description
7:0	R/W	10000000b	VCO_divr	VCO comparison divider (VCD): this divider divides down the VCO to compare it with the divided down reference. Binary value reflects the divider ratio 01h: Minimum value (VCD = 1) . . . FFh: Maximum value (VCD = 255)

3.1.15 1Bh:Built In Self-Test (BIST) Transmitter 20 bit User Programmable Pattern

Table 3-16. Built In Self-Test (BIST) Transmitter 20 bit User Programmable Pattern (BIST_pattern0: Address 1Bh)

Bits	Type	Default	Label	Description
3:0	R/W	1100b	pattern	Sets the 20 bit user programmable pattern used in the BIST [3] MSB : Pattern bit#19 [2] : Pattern bit#18 [1] : Pattern bit#17 [0] LSB : Pattern bit#16

3.1.16 1Ch:Built In Self-Test (BIST) Transmitter 16/20 bit User Programmable Pattern

Table 3-17. Built In Self-Test (BIST) Transmitter 16/20 bit User Programmable Pattern (BIST_pattern1: Address 1Ch)

Bits	Type	Default	Label	Description
7:0	R/W	11001100b	pattern	Sets the 16/20 bit user programmable pattern used in the BIST [7] MSB : Pattern bit#15 [6] : Pattern bit#14 [5] : Pattern bit#13 [4] : Pattern bit#12 [3] : Pattern bit#11 [2] : Pattern bit#10 [1] : Pattern bit#9 [0] LSB : Pattern bit#8

3.1.17 1Dh:Built In Self-Test (BIST) Transmitter 16/20 bit User Programmable Pattern

Table 3-18. Built In Self-Test (BIST) Transmitter 16/20 bit User Programmable Pattern (BIST_pattern2: Address 1Dh)

Bits	Type	Default	Label	Description
7:0	R/W	11001100b	pattern	Sets the 16/20 bit user programmable pattern used in the BIST [7] MSB : Pattern bit#7 [6] : Pattern bit#6 [5] : Pattern bit#5 [4] : Pattern bit#4 [3] : Pattern bit#3 [2] : Pattern bit#2 [1] : Pattern bit#1 [0] LSB : Pattern bit#0

3.1.18 1Fh:Built In Self-Test (BIST) Transmitter Alarm

Table 3-19. Built In Self-Test (BIST) Transmitter Alarm (BISTtx_alarm: Address 1Fh)

Bits	Type	Default	Label	Description
7	R	N/A	tx_LOL	Loss of lock for the BIST Tx PLL (active when <i>BISTtx_ctrl</i> [1] = 1) 0b: Normal operation 1b: Loss of lock
6:5	R/W	00b	Reserved	N/A (00 default)
4:0	R/W	00000b	MSPD internal	N/A (00000 default)

3.1.19 20h:Internal Junction Temperature Monitor

Table 3-20. Internal Junction Temperature Monitor (Temp_mon: Address 20h)

Bits	Type	Default	Label	Description
3:2	R/W	00b	Reserved	N/A (00 default)
1	R/W	0b	en_temp_mon	Power up and enable the temperature monitor 1b: Power up and enable temperature monitor 0b: Disable temperature monitor (default)
0	R/W	0b	strobe_temp	Strobes ADC for temperature measurement 1b: Read temperature 0b: Ok to read temperature (default) Note: To strobe ADC, a rising edge should be provided by writing 1b, then writing 0b to return to default state.

3.1.20 21h:Internal Junction Temperature Value

Table 3-21. Internal Junction Temperature Value (Temp_value: Address 21h)

Bits	Type	Default	Label	Description																																										
3:0	R	N/A	temp	A read of these bits returns the temperature from the last write cycle (to strobe_temp) <table border="0"> <tr> <td>Junction Temperature</td> <td>temp</td> <td>Condition</td> </tr> <tr> <td>$T_j \geq 130^\circ\text{C}$</td> <td>1100b</td> <td>High-alarm</td> </tr> <tr> <td>$130^\circ\text{C} > T_j \geq 120^\circ\text{C}$</td> <td>1011b</td> <td>High-alarm</td> </tr> <tr> <td>$120^\circ\text{C} > T_j \geq 110^\circ\text{C}$</td> <td>1010b</td> <td>High-warning</td> </tr> <tr> <td>$110^\circ\text{C} > T_j \geq 100^\circ\text{C}$</td> <td>1001b</td> <td>Normal</td> </tr> <tr> <td>$100^\circ\text{C} > T_j \geq 90^\circ\text{C}$</td> <td>1000b</td> <td>Normal</td> </tr> <tr> <td>$90^\circ\text{C} > T_j \geq 80^\circ\text{C}$</td> <td>0111b</td> <td>Normal</td> </tr> <tr> <td>$80^\circ\text{C} > T_j \geq 70^\circ\text{C}$</td> <td>0110b</td> <td>Normal</td> </tr> <tr> <td>$70^\circ\text{C} > T_j \geq 60^\circ\text{C}$</td> <td>0101b</td> <td>Normal</td> </tr> <tr> <td>$60^\circ\text{C} > T_j \geq 50^\circ\text{C}$</td> <td>0100b</td> <td>Normal</td> </tr> <tr> <td>$50^\circ\text{C} > T_j \geq 40^\circ\text{C}$</td> <td>0011b</td> <td>Normal</td> </tr> <tr> <td>$40^\circ\text{C} > T_j \geq 30^\circ\text{C}$</td> <td>0010b</td> <td>Low-warning</td> </tr> <tr> <td>$30^\circ\text{C} > T_j \geq 20^\circ\text{C}$</td> <td>0001b</td> <td>Low-alarm</td> </tr> <tr> <td>$20^\circ\text{C} > T_j \geq 10^\circ\text{C}$</td> <td>0000b</td> <td>Low-alarm</td> </tr> </table>	Junction Temperature	temp	Condition	$T_j \geq 130^\circ\text{C}$	1100b	High-alarm	$130^\circ\text{C} > T_j \geq 120^\circ\text{C}$	1011b	High-alarm	$120^\circ\text{C} > T_j \geq 110^\circ\text{C}$	1010b	High-warning	$110^\circ\text{C} > T_j \geq 100^\circ\text{C}$	1001b	Normal	$100^\circ\text{C} > T_j \geq 90^\circ\text{C}$	1000b	Normal	$90^\circ\text{C} > T_j \geq 80^\circ\text{C}$	0111b	Normal	$80^\circ\text{C} > T_j \geq 70^\circ\text{C}$	0110b	Normal	$70^\circ\text{C} > T_j \geq 60^\circ\text{C}$	0101b	Normal	$60^\circ\text{C} > T_j \geq 50^\circ\text{C}$	0100b	Normal	$50^\circ\text{C} > T_j \geq 40^\circ\text{C}$	0011b	Normal	$40^\circ\text{C} > T_j \geq 30^\circ\text{C}$	0010b	Low-warning	$30^\circ\text{C} > T_j \geq 20^\circ\text{C}$	0001b	Low-alarm	$20^\circ\text{C} > T_j \geq 10^\circ\text{C}$	0000b	Low-alarm
Junction Temperature	temp	Condition																																												
$T_j \geq 130^\circ\text{C}$	1100b	High-alarm																																												
$130^\circ\text{C} > T_j \geq 120^\circ\text{C}$	1011b	High-alarm																																												
$120^\circ\text{C} > T_j \geq 110^\circ\text{C}$	1010b	High-warning																																												
$110^\circ\text{C} > T_j \geq 100^\circ\text{C}$	1001b	Normal																																												
$100^\circ\text{C} > T_j \geq 90^\circ\text{C}$	1000b	Normal																																												
$90^\circ\text{C} > T_j \geq 80^\circ\text{C}$	0111b	Normal																																												
$80^\circ\text{C} > T_j \geq 70^\circ\text{C}$	0110b	Normal																																												
$70^\circ\text{C} > T_j \geq 60^\circ\text{C}$	0101b	Normal																																												
$60^\circ\text{C} > T_j \geq 50^\circ\text{C}$	0100b	Normal																																												
$50^\circ\text{C} > T_j \geq 40^\circ\text{C}$	0011b	Normal																																												
$40^\circ\text{C} > T_j \geq 30^\circ\text{C}$	0010b	Low-warning																																												
$30^\circ\text{C} > T_j \geq 20^\circ\text{C}$	0001b	Low-alarm																																												
$20^\circ\text{C} > T_j \geq 10^\circ\text{C}$	0000b	Low-alarm																																												

3.1.21 30h:CDR/RCLK Loss of Lock Register Alarm Status

Table 3-22. CDR/RCLK Loss of Lock Register Alarm Status (Alarm_LOL: Address 30h)

Bits	Type	Default	Label	Description
7:4	R/W	0000b	MSPD internal	N/A (0000 default)
3:0	R	N/A	LOL	Latched loss of lock alarm status 1b = loss of CDR/RCLK lock, 0b = normal operation [3]: CDR/RCLK 3 [2]: CDR/RCLK 2 [1]: CDR/RCLK 1 [0]: CDR/RCLK 0 Note: After a clear (<i>Globctrl</i> [0] = 1), this register is cleared and will latch any new alarms that make a L to H transition, and set any pre-existing alarm conditions to H.

3.1.22 31h:Loss of Activity Register Alarm Status

Table 3-23. Loss of Activity Register Alarm Status (Alarm_LOA: Address 31h)

Bits	Type	Default	Label	Description
7:4	R/W	0000b	MSPD internal	N/A (0000 default)
3:0	R	N/A	LOA	Latched loss of activity alarm status 1b = loss of input signal, 0b = normal operation [3]: Channel 3 [2]: Channel 2 [1]: Channel 1 [0]: Channel 0 Note: After a clear (<i>Globctrl</i> [0] = 1), this register is cleared and will latch any new alarms that make a L to H transition, and set any pre-existing alarm conditions to H.

3.1.23 32h:VCO Trim Alarm Window

Table 3-24. VCO Trim Alarm Window Trim (Alarm_trim: Address 32h)

Bits	Type	Default	Label	Description
7:4	R/W	0000b	MSPD internal	N/A (0000 default)
3:0	R	0000b	Alarm_trim	Indicates that CDR N is unavailable due to VCO coarse trimming (Read only) 1b= Trim, 0b = Normal Operation [3]: CDR #3 (Mapped to Output 3) [2]: CDR #2 (Mapped to Output 2) [1]: CDR #1 (Mapped to Output 1) [0]: CDR #0 (Mapped to Output 0) Note: After a clear (<i>Globctrl</i> [0]=1), the register is cleared and 1) will latch any new alarms that makes a L to H transition and 2) set any pre-existing alarm conditions to H.

3.2 Individual Channel/CDR/RCLK Control

Multiple Instance Nomenclature

- N = 0 for channel/CDR/RCLK 0, N = 1 for channel/CDR/RCLK 1,..., N = 3 for channel/CDR/RCLK 3.
- M = 4 for channel/CDR/RCLK 0, M = 5 for channel/CDR/RCLK 1,..., M = 7 for channel/CDR/RCLK 3. For example channel/CDR/RCLK 0 starts at address 40h, channel/CDR/RCLK 1 at 50h, channel/CDR/RCLK 2 at 60h, channel/CDR/RCLK 3 at 70h.

3.2.1 M0h:CDR N Control Register A

Table 3-25. CDR N Control Register A (RCLK_ctrlA_N: Address M0h)

Bits	Type	Default	Label	Description
7	R/W	0b	Softreset	Resets an individual CDR#N (Setup registers remain unchanged, need to softreset after rate change) 0b: Normal Operation [Default] 1b: Reset Single CDR only
6	R/W	0b	force_filter_reset	Shorts the charge pump output terminals for free running VCO in the CDR (test mode) 0b: Open Circuit for Normal Operation [Default] 1b: Short Circuit for test
5	R/W	0b	inh_force	Manual Control of the Output Inhibit if Cdr_ctrlA_N[3]=0 0b: Normal operation [Default] 1b: Forced inhibit
4	R/W	0b	lol_force	Manual force LOL and Freq. Acq. only if Cdr_ctrlA_N[2]=0 0b: Force LOL=L and freq. acquisition circuit is disabled for phase lock (Default) 1b: Force LOL=H and both the phase and freq. acquisition circuit is on
3	R/W	1b	autoinh_en	Auto inhibit of the output N to to logic L (output P=Low, output N=High) if CDR N has a LOL or LOS condition (or Trim Alarm) 0b: Auto Inhibit disabled, Cdr_ctrlA_N[5] determines inhibit force state 1b: Auto Inhibit enabled [Default]
2	R/W	1b	freqwin_en	Disables use of Frequency Detector for freq. acquisition 0b: Freq. Acquisition is disabled and controlled with Cdr_ctrlA_N[4] (test mode) 1b: Freq. acquisition is enabled for normal operation [Default]
1	R/W	0b	los_en	Enables the transition density based Loss of Signal Detector for Output N 0b: Disable and power down LOS circuit 1b: Enable LOS circuit [default] Note: Signal Detector is not mapped to input channel but the output channel [Delete mapping line for CDR products]
0	R/W	1b	trim_en	Enables Auto trimming of the VCO center frequency 1b: Auto Trim Enabled for Normal Operation [Default] 0b: Force Time with trim_force_N registers
<p>Notes:</p> <p>1: N can denote input channel #, output channel#, or CDR # depending on the context.</p> <p>2: M is the address MSB and its N+4h.</p> <p>3: Example: N=0h & M=4h for CDR0, N=1h & M=5h for CDR1. This implies CDR0 at Address 40h, CDR 1 at 50h, CDR 2 at 60h, ..., CDR 7 at 80h.</p>				

3.2.2 M1h:CDR/RCLK N Control Register B

Table 3-26. CDR N Control Register B (RCLK_ctrlB_N: Address M1h)

Bits	Type	Default	Label	Description
7:6	R/W	00b	CDR mode	Determines State of the PLL 00b: CDR Powered Up and Active [Default] 01b: CDR Powered Up and Bypassed 10b: CDR Powered Down (No signal through) 11b: CDR Powered Down and Bypassed
5	R/W	0b		Enables CDR to operate correctly with a 1010 pattern (100% transition density) 1b: enabled 0b: normal mode, 50% transition density expected (Default)
4	R/W	0b	Reserved	Reserved (0=Default)
3:0	R/W	0000b	data_rate	Data rate divider (DRD): This divides down the VCO frequency to the desired data rate to match input data rate. 0000b=VCO/1 [Default] 0001b=VCO/2 0010b=VCO/4 0011b=VCO/8 0100b=VCO/12 0101b=VCO/16 0110b=VCO/24 0111b=VCO/32 1000b=VCO/48 Consult VCO Fvco, max and Fvco, min to determine frequency range of each DRD ratio.

Notes:

1: N can denote input channel #, output channel#, or CDR # depending on the context.

2: M is the address MSB and its N+4h.

3: Example: N=0h & M=4h for CDR0, N=1h & M=5h for CDR1. This implies CDR0 at Address 40h, CDR 1 at 50h, CDR 2 at 60h, ..., CDR 7 at 80h.

3.2.3 M2h:CDR/RCLK N Control Register C

Table 3-27. CDR/RCLK N Control Register C (RCLK_ctrlC_N: Address M2h)

Bits	Type	Default	Label	Description
7:0	R/W	10000000b	VCO_divr	VCO comparison divider (VCD): this divides down the VCO, to compare it with the scaled reference clock. Binary value reflects the divider ratio 1h: Minimum value (VCD = 1) . . . FFh: Maximum value (VCD = 255)

3.2.4 M3h:Output Buffer Control for CDR/RCLK N

Table 3-28. Output Buffer Control for CDR/RCLK N (*Out_ctrl_N*: Address M3h)

Bits	Type	Default	Label	Description
7:6	R/W	10b	outlvl	Determines the output swing of a data and/or clock buffer for CDR/RCLK N In PCML mode: 00b: Power down 01b: 550 mV 10b: 900 mV (default) 11b: 1200 mV For LVDS, the output swing is reduced to: 00b: Power down 01b: RRL 450 mV 10b: GPL 650 mV (default) 11b: 1V For PCML+, the output swing is increased to: 00b: Power down 01b: 900 mV 10b: 1200 mV (default) 11b: 1600 mV
5:4	R/W	00b	Reserved	N/A
3	R/W	0b	data_pol_flip	Flips the polarity of the output data 0b: Normal (default) 1b: Polarity flip
2	R/W	1b	dataout_en	Enables the data output driver N 1b: Data output enabled to level specified in <i>Out_ctrl_N</i> [7:6] (default) 0b: Data output disabled and powered down
1	R/W	0b	clkout_en	Enables the clock output driver N 1b: Clock output enabled to level specified in <i>Out_ctrl_N</i> [7:6] 0b: Clock output disabled and powered down (default)
0	R/W	0b	clk_pol_flip	Flips the polarity of the output clock 0b: Normal (default) 1b: Polarity flip

3.2.5 M4h:Output Buffer Pre-Emphasis Control for Output N

Table 3-29. Output Buffer Pre-Emphasis Control for Output N (Preemp_ctrl_N: Address M4h)

Bits	Type	Default	Label	Description
7	R/W	0b	Reserved	N/A (0 default)
6:3	R/W	1000b	MSPD internal	N/A (1000 default)
2:0	R/W	000b	preemph	Selects the output pre-emphasis level 111b: 200% 110b: 150% 101b: 100% 100b: 75% 011b: 50% 010b: 37.5% 001b: 25% 000b: Pre-emphasis off (default)

3.2.6 M5h:Input Equalization Control for Output N

Table 3-30. Input Equalization Control for Output N (Ineq_ctrl_N: Address M5h)

Bits	Type	Default	Label	Description
7	R/W	0b	Reserved	N/A (0 default)
6:5	R/W	00b	MSPD internal	N/A (00 default)
4	R/W	0b	en_DCservo	Enables DC servo in the input channel to remove offset based deterministic jitter 0b: DC servo D_j attenuator off (default) 1b: DC servo D_j attenuator on
3	R/W	0b	MSPD internal	N/A (0 default)
2:0	R/W	000b	in_eq	Selects the input equalization level 111b: Maximum input equalization level . . . 100b: Nominal input equalization level . . . 001b: Minimum input equalization level 000b: Input equalization disabled (default) Note: The 100b setting is optimized for PCB trace lengths between 10 - 46 inches, although other settings may be optimal for some applications.

3.2.7 M6h:CDR/RCLK N Loop Bandwidth and Data Sampling Point Adjust

Table 3-31. CDR/RCLK N Loop Bandwidth and Data Sampling Point Adjust (Phadj_ctrl_N: Address M6h)

Bits	Type	Default	Label	Description
7:6	R/W	10b	i_trim	Adjusts the charge-pump current; the loop bandwidth (F_{LBW}) scales proportionately 00b: 0.65x 01b: 0.8x 10b: Nominal (default) 11b: 1.15x
5:4	R/W	01b	r_sel	Adjusts the resistor of the CDR/RCLK loop filter; the loop bandwidth (F_{LBW}) scales proportionately 00b: 80% of the nominal value 01b: Nominal (default) 10b: 4x nominal value 11b: 6x nominal value
3:0	R/W	0000b	phase_adj	Adjusts the static phase offset (sampling point) of the data 1111b: -122.5 mUI 1110b: -105 mUI 1101b: -87.5 mUI 1100b: -70 mUI 1011b: -52.5 mUI 1010b: -35.0 mUI 1001b: -17.5 mUI 1000b: 0 mUI 0000b: 0 mUI (default) 0001b: 17.5 mUI 0010b: 35.0 mUI 0011b: 52.5 mUI 0100b: 70.0 mUI 0101b: 87.5 mUI 0110b: 105 mUI 0111b: 122.5 mUI

3.2.8 M9h:CDR/RCLK N LOL Window Control

Table 3-32. CDR/RCLK N LOL Window Control (LOL_ctrl_N: Address M9h) (1 of 2)

Bits	Type	Default	Label	Description
7:5	R/W	101b	tacq_LOL	Sets the value for the LOL reference window Code Value 000b 128 001b 256 010b 512 011b 1024 100b 2048 101b 4096 (default) 110b 8192 111b 16384

Table 3-32. CDR/RCLK N LOL Window Control (LOL_ctrl_N: Address M9h) (2 of 2)

Bits	Type	Default	Label	Description																																																			
4:1	R/W	0100b	narwin_LOL	<p>Sets the narrow LOL window for the LOL = H to LOL = L transition (transition to in lock threshold)</p> <table border="1"> <thead> <tr> <th>Code</th> <th>Value</th> </tr> </thead> <tbody> <tr><td>0000b</td><td>2</td></tr> <tr><td>0001b</td><td>3</td></tr> <tr><td>0010b</td><td>4</td></tr> <tr><td>0011b</td><td>6</td></tr> <tr><td>0100b</td><td>8 (default)</td></tr> <tr><td>0101b</td><td>12</td></tr> <tr><td>0110b</td><td>16</td></tr> <tr><td>0111b</td><td>24</td></tr> <tr><td>1000b</td><td>9</td></tr> <tr><td>1001b</td><td>10</td></tr> <tr><td>1010b</td><td>11</td></tr> <tr><td>1011b</td><td>12</td></tr> <tr><td>1100b</td><td>13</td></tr> <tr><td>1101b</td><td>14</td></tr> <tr><td>1110b</td><td>15</td></tr> <tr><td>1111b</td><td>32</td></tr> </tbody> </table>	Code	Value	0000b	2	0001b	3	0010b	4	0011b	6	0100b	8 (default)	0101b	12	0110b	16	0111b	24	1000b	9	1001b	10	1010b	11	1011b	12	1100b	13	1101b	14	1110b	15	1111b	32																	
Code	Value																																																						
0000b	2																																																						
0001b	3																																																						
0010b	4																																																						
0011b	6																																																						
0100b	8 (default)																																																						
0101b	12																																																						
0110b	16																																																						
0111b	24																																																						
1000b	9																																																						
1001b	10																																																						
1010b	11																																																						
1011b	12																																																						
1100b	13																																																						
1101b	14																																																						
1110b	15																																																						
1111b	32																																																						
0	R/W	0b	widwin_LOL	<p>Sets the wide LOL window for the LOL = L to LOL = H transition (transition to out of lock threshold)</p> <table border="1"> <thead> <tr> <th>Narrow Code</th> <th>Wide Code 0b (default)</th> <th>Wide Code 1b</th> </tr> </thead> <tbody> <tr><td>0000b</td><td>3</td><td>8</td></tr> <tr><td>0001b</td><td>4</td><td>12</td></tr> <tr><td>0010b</td><td>6</td><td>16</td></tr> <tr><td>0011b</td><td>8</td><td>24</td></tr> <tr><td>0100b</td><td>12</td><td>32</td></tr> <tr><td>0101b</td><td>16</td><td>32</td></tr> <tr><td>0110b</td><td>24</td><td>32</td></tr> <tr><td>0111b</td><td>32</td><td>32</td></tr> <tr><td>1000b</td><td>12</td><td>32</td></tr> <tr><td>1001b</td><td>12</td><td>32</td></tr> <tr><td>1010b</td><td>12</td><td>32</td></tr> <tr><td>1011b</td><td>16</td><td>32</td></tr> <tr><td>1100b</td><td>16</td><td>32</td></tr> <tr><td>1101b</td><td>16</td><td>32</td></tr> <tr><td>1110b</td><td>16</td><td>32</td></tr> <tr><td>1111b</td><td>32</td><td>32</td></tr> </tbody> </table>	Narrow Code	Wide Code 0b (default)	Wide Code 1b	0000b	3	8	0001b	4	12	0010b	6	16	0011b	8	24	0100b	12	32	0101b	16	32	0110b	24	32	0111b	32	32	1000b	12	32	1001b	12	32	1010b	12	32	1011b	16	32	1100b	16	32	1101b	16	32	1110b	16	32	1111b	32	32
Narrow Code	Wide Code 0b (default)	Wide Code 1b																																																					
0000b	3	8																																																					
0001b	4	12																																																					
0010b	6	16																																																					
0011b	8	24																																																					
0100b	12	32																																																					
0101b	16	32																																																					
0110b	24	32																																																					
0111b	32	32																																																					
1000b	12	32																																																					
1001b	12	32																																																					
1010b	12	32																																																					
1011b	16	32																																																					
1100b	16	32																																																					
1101b	16	32																																																					
1110b	16	32																																																					
1111b	32	32																																																					

3.2.9 MAh: Jitter Reduction Control

Table 3-33. Jitter Reduction Control (Jitter_reduc_N: Address MAh)

Bits	Type	Default	Label	Description
7:6	R/W	01b	MSPD internal	N/A
5	R/W	0b	lowjitter	When data-rate is in the range (2.45 Gbps - 2.55 Gbps)/DRD, setting this bit to 1b will reduce output jitter (DRD is data-rate divider). 1b: When data rate is in the range (2.45 Gbps - 2.55 Gbps)/DRD 0b: When data rate is not in the range (2.45 Gbps - 2.55 Gbps)/DRD Note: This bit should be set to 1b for SONET STS-N, and Gigabit Ethernet applications.
4:0	R/W		MSPD internal	Any value may be written to this register with no effect on performance.



4.0 Appendices

4.1 Glossary of Terms/Acronyms

Table 4-1 contains a list of acronyms used in this data sheet.

Table 4-1. Acronyms

IE	Input Equalizer
BER	Bit-Error Rate
BIST	Built-In Self Test
RCLK	Reclocker
DRD	Data-Rate Divider
DVB	Digital Video Broadcast
EVM	Evaluation Module
FLL	Frequency Lock Loop
FRA	Frequency Reference Acquisition
ISI	Inter-Symbol Interference
LOA	Loss of Activity
LOL	Loss of Lock
LOLCir	Loss of Lock Circuitry
NRW	Narrow Reference Window
PCB	Printed Circuit Board
PLL	Phase Lock Loop
RFD	Reference Frequency Divider
SMPTTE	Society of Motion Picture and Television Engineers
SONET	Synchronous Optical Network
VCD	VCO Comparison Divider
WRW	Wide Reference Window

4.2 Reference Documents

4.2.1 External

The following external documents were referenced in this data sheet.

- The I²C Bus Specification version 2.1
- Application Notes for Surface Mount Assembly of QFN Packages
- Amkor Technology Thermal Test Report TT-00-06
- SMPTE 292M, SMPTE 259M, SMPTE 344M
- DVB-ASI
- Synchronous Optical Network (SONET) Transport Systems: Common Generic Criteria GR-253-CORE
- Fibre Channel - Methodologies for Jitter and Signal Quality Specification - MJSQ & FC-PI-2

4.2.2 Mindspeed

The following Mindspeed documents were referenced in this data sheet.

- M2125x and M2126x ARD Software Description (212xx-SWG-001)
- M2125x Evaluation Module User Guide (2125x-EVMD-001)
- Jitter tolerance and generation of Mindspeed Technologies crosspoint switches and clock & data recovery arrays (2110x-APP-003)

www.mindspeed.com

General Information:
Telephone: (949) 579-3000
Headquarters - Newport Beach
4000 MacArthur Blvd., East Tower
Newport Beach, CA 92660

© 2006-2009 Mindspeed Technologies®, Inc. All rights reserved.

Information in this document is provided in connection with Mindspeed Technologies® ("Mindspeed®") products. These materials are provided by Mindspeed as a service to its customers and may be used for informational purposes only. Except as provided in Mindspeed's Terms and Conditions of Sale for such products or in any separate agreement related to this document, Mindspeed assumes no liability whatsoever. Mindspeed assumes no responsibility for errors or omissions in these materials. Mindspeed may make changes to specifications and product descriptions at any time, without notice. Mindspeed makes no commitment to update the information and shall have no responsibility whatsoever for conflicts or incompatibilities arising from future changes to its specifications and product descriptions. No license, express or implied, by estoppel or otherwise, to any intellectual property rights is granted by this document.

THESE MATERIALS ARE PROVIDED "AS IS" WITHOUT WARRANTY OF ANY KIND, EITHER EXPRESS OR IMPLIED, RELATING TO SALE AND/OR USE OF MINDSPEED PRODUCTS INCLUDING LIABILITY OR WARRANTIES RELATING TO FITNESS FOR A PARTICULAR PURPOSE, CONSEQUENTIAL OR INCIDENTAL DAMAGES, MERCHANTABILITY, OR INFRINGEMENT OF ANY PATENT, COPYRIGHT OR OTHER INTELLECTUAL PROPERTY RIGHT. MINDSPEED FURTHER DOES NOT WARRANT THE ACCURACY OR COMPLETENESS OF THE INFORMATION, TEXT, GRAPHICS OR OTHER ITEMS CONTAINED WITHIN THESE MATERIALS. MINDSPEED SHALL NOT BE LIABLE FOR ANY SPECIAL, INDIRECT, INCIDENTAL, OR CONSEQUENTIAL DAMAGES, INCLUDING WITHOUT LIMITATION, LOST REVENUES OR LOST PROFITS, WHICH MAY RESULT FROM THE USE OF THESE MATERIALS.

Mindspeed products are not intended for use in medical, lifesaving or life sustaining applications. Mindspeed customers using or selling Mindspeed products for use in such applications do so at their own risk and agree to fully indemnify Mindspeed for any damages resulting from such improper use or sale.