

# CD4017BM/CD4017BC Decade Counter/Divider with 10 Decoded Outputs

# CD4022BM/CD4022BC Divide-by-8 Counter/Divider with 8 Decoded Outputs

## General Description

The CD4017BM/CD4017BC is a 5-stage divide-by-10 Johnson counter with 10 decoded outputs and a carry out bit.

The CD4022BM/CD4022BC is a 4-stage divide-by-8 Johnson counter with 8 decoded outputs and a carry-out bit.

These counters are cleared to their zero count by a logical "1" on their reset line. These counters are advanced on the positive edge of the clock signal when the clock enable signal is in the logical "0" state.

The configuration of the CD4017BM/CD4017BC and CD4022BM/CD4022BC permits medium speed operation and assures a hazard free counting sequence. The 10/8 decoded outputs are normally in the logical "0" state and go to the logical "1" state only at their respective time slot. Each decoded output remains high for 1 full clock cycle. The carry-out signal completes a full cycle for every 10/8 clock input cycles and is used as a ripple carry signal to any succeeding stages.

## Features

- Wide supply voltage range
- High noise immunity
- Low power
  - TTL compatibility
- Medium speed operation
- Low power
- Fully static operation

3.0V to 15V  
0.45  $V_{DD}$  (typ.)  
Fan out of 2 driving 74L  
or 1 driving 74LS  
5.0 MHz (typ.)  
with 10V  $V_{DD}$   
10  $\mu$ W (typ.)

## Applications

- Automotive
- Instrumentation
- Medical electronics
- Alarm systems
- Industrial electronics
- Remote metering

## Connection Diagrams

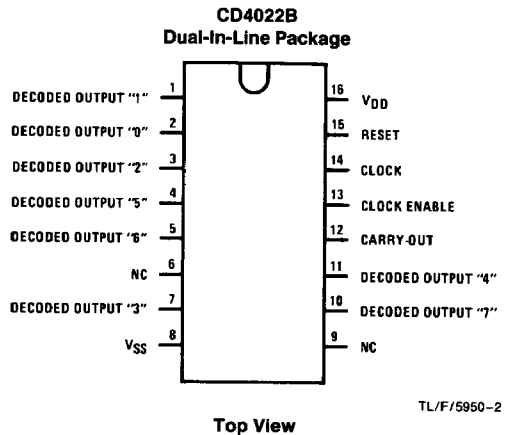
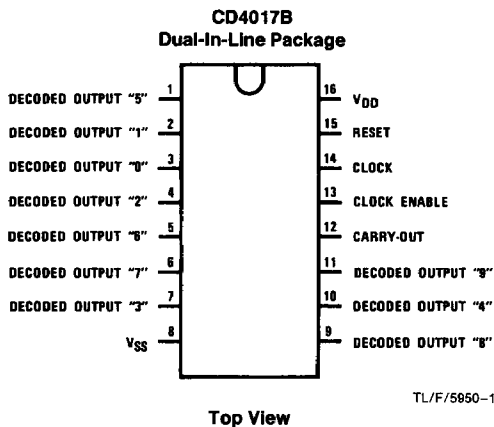

Order Number CD4017B\* or CD4022B\*

\*Please look into Section 8, Appendix D for availability of various package types.

### Absolute Maximum Ratings (Notes 1 & 2)

If Military/Aerospace specified devices are required, contact the National Semiconductor Sales Office/Distributors for availability and specifications.

DC Supply Voltage ( $V_{DD}$ )	-0.5 $V_{DC}$ to +18 $V_{DC}$
Input Voltage ( $V_{IN}$ )	-0.5 $V_{DC}$ to $V_{DD}$ + 0.5 $V_{DC}$
Storage Temperature ( $T_S$ )	-65°C to +150°C
Power Dissipation ( $P_D$ )	
Dual-In-Line	700 mW
Small Outline	500 mW
Lead Temperature ( $T_L$ )	
(Soldering, 10 seconds)	260°C

### Recommended Operating Conditions (Note 2)

DC Supply Voltage ( $V_{DD}$ )	+3 $V_{DC}$ to +15 $V_{DC}$
Input Voltage ( $V_{IN}$ )	0 to $V_{DD}$ $V_{DC}$
Operating Temperature Range ( $T_A$ )	
CD4017BM, CD4022BM	-55°C to +125°C
CD4017BC, CD4022BC	-40°C to +85°C

### DC Electrical Characteristics CD4017BM, CD4022BM (Note 2)

Symbol	Parameter	Conditions	-55°C		+25°			+125°C		Units
			Min	Max	Min	Typ	Max	Min	Max	
$I_{DD}$	Quiescent Device Current	$V_{DD} = 5V, V_{IN} = V_{DD}$ or $V_{SS}$		5		0.3	5		150	$\mu A$
		$V_{DD} = 10V, V_{IN} = V_{DD}$ or $V_{SS}$		10		0.5	10		300	$\mu A$
		$V_{DD} = 15V, V_{IN} = V_{DD}$ or $V_{SS}$		20		1.0	20		600	$\mu A$
$V_{OL}$	Low Level Output Voltage	$ I_O  < 1.0 \mu A$								
		$V_{DD} = 5V$		0.05		0	0.05		0.05	V
		$V_{DD} = 10V$		0.05		0	0.05		0.05	V
$V_{OH}$	High Level Output Voltage	$ I_O  < 1.0 \mu A$								
		$V_{DD} = 5V$	4.95		4.95	5		4.95		V
		$V_{DD} = 10V$	9.95		9.95	10		9.95		V
$V_{IL}$	Low Level Input Voltage	$ I_O  < 1.0 \mu A$								
		$V_{DD} = 5V, V_O = 0.5V$ or 4.5V		1.5			1.5		1.5	V
		$V_{DD} = 10V, V_O = 1.0V$ or 9.0V		3.0			3.0		3.0	V
$V_{IH}$	High Level Input Voltage	$ I_O  < 1.0 \mu A$								
		$V_{DD} = 5V, V_O = 0.5V$ or 4.5V	3.5		3.5			3.5		V
		$V_{DD} = 10V, V_O = 1.0V$ or 9.0V	7.0		7.0			7.0		V
$I_{OL}$	Low Level Output Current (Note 3)	$V_{DD} = 5V, V_O = 0.4V$	0.64		0.51	0.88		0.36		mA
		$V_{DD} = 10V, V_O = 0.5V$	1.6		1.3	2.25		0.9		mA
		$V_{DD} = 15V, V_O = 1.5V$	4.2		3.4	8.8		2.4		mA
$I_{OH}$	High Level Output Current (Note 3)	$V_{DD} = 5V, V_O = 4.6V$	-0.25		-0.2	-0.36		-0.14		mA
		$V_{DD} = 10V, V_O = 9.5V$	-0.62		-0.5	-0.9		-0.35		mA
		$V_{DD} = 15V, V_O = 13.5V$	-1.8		-1.5	-3.5		-1.1		mA
$I_{IN}$	Input Current	$V_{DD} = 15V, V_{IN} = 0V$		-0.1		$-10^{-5}$	-0.1		-1.0	$\mu A$
		$V_{DD} = 15V, V_{IN} = 15V$		0.1		$10^{-5}$	0.1		1.0	$\mu A$

### DC Electrical Characteristics CD4017BC, CD4022BC (Note 2)

Symbol	Parameter	Conditions	-40°C		+25°			+85°C		Units
			Min	Max	Min	Typ	Max	Min	Max	
$I_{DD}$	Quiescent Device Current	$V_{DD} = 5V$		20		0.5	20		150	$\mu A$
		$V_{DD} = 10V$		40		1.0	40		300	$\mu A$
		$V_{DD} = 15V$		80		5.0	80		600	$\mu A$
$V_{OL}$	Low Level Output Voltage	$ I_O  < 1.0 \mu A$								
		$V_{DD} = 5V$		0.05		0	0.05		0.05	V
		$V_{DD} = 10V$		0.05		0	0.05		0.05	V
$V_{OH}$	High Level Output Voltage	$ I_O  < 1.0 \mu A$								
		$V_{DD} = 5V$	4.95		4.95	5		4.95		V
		$V_{DD} = 10V$	9.95		9.95	10		9.95		V
$V_{OH}$	High Level Output Voltage	$ I_O  < 1.0 \mu A$								
		$V_{DD} = 5V$	4.95		4.95	5		4.95		V
		$V_{DD} = 10V$	9.95		9.95	10		9.95		V
$V_{OH}$	High Level Output Voltage	$ I_O  < 1.0 \mu A$								
		$V_{DD} = 5V$	4.95		4.95	5		4.95		V
		$V_{DD} = 10V$	9.95		9.95	10		9.95		V
$V_{OH}$	High Level Output Voltage	$ I_O  < 1.0 \mu A$								
		$V_{DD} = 5V$	4.95		4.95	5		4.95		V
		$V_{DD} = 10V$	9.95		9.95	10		9.95		V

**Note 1:** "Absolute Maximum Ratings" are those values beyond which the safety of the device cannot be guaranteed, they are not meant to imply that the devices should be operated at these limits. The table of "Recommended Operating Conditions" and "Electrical Characteristics" provides conditions for actual device operation.

**Note 2:**  $V_{SS} = 0V$  unless otherwise specified.

**Note 3:**  $I_{OL}$  and  $I_{OH}$  are tested one output at a time.

## DC Electrical Characteristics CD4017BC, CD4022BC (Note 2) (Continued)

Symbol	Parameter	Conditions	-40°C		+25°			+85°C		Units
			Min	Max	Min	Typ	Max	Min	Max	
V <sub>IL</sub>	Low Level Input Voltage	I <sub>O</sub>   < 1.0 μA								
		V <sub>DD</sub> = 5V, V <sub>O</sub> = 0.5V or 4.5V		1.5			1.5		1.5	V
		V <sub>DD</sub> = 10V, V <sub>O</sub> = 1.0V or 9.0V		3.0			3.0		3.0	V
		V <sub>DD</sub> = 15V, V <sub>O</sub> = 1.5V or 13.5V		4.0			4.0		4.0	V
V <sub>IH</sub>	High Level Input Voltage	I <sub>O</sub>   < 1.0 μA								
		V <sub>DD</sub> = 5V, V <sub>O</sub> = 0.5V or 4.5V	3.5		3.5			3.5		V
		V <sub>DD</sub> = 10V, V <sub>O</sub> = 1.0V or 9.0V	7.0		7.0			7.0		V
		V <sub>DD</sub> = 15V, V <sub>O</sub> = 1.5V or 13.5V	11.0		11.0			11.0		V
I <sub>OL</sub>	Low Level Output Current (Note 3)	V <sub>DD</sub> = 5V, V <sub>O</sub> = 0.4V	0.52		0.44	0.88		0.36		mA
		V <sub>DD</sub> = 10V, V <sub>O</sub> = 0.5V	1.3		1.1	2.25		0.9		mA
		V <sub>DD</sub> = 15V, V <sub>O</sub> = 1.5V	3.6		3.0	8.8		2.4		mA
I <sub>OH</sub>	High Level Output Current (Note 3)	V <sub>DD</sub> = 5V, V <sub>O</sub> = 4.6V	-0.2		-0.16	-0.36		-0.12		mA
		V <sub>DD</sub> = 10V, V <sub>O</sub> = 9.5V	-0.5		-0.4	-0.9		-0.3		mA
		V <sub>DD</sub> = 15V, V <sub>O</sub> = 13.5V	-1.4		-1.2	-3.5		-1.0		mA
I <sub>IN</sub>	Input Current	V <sub>DD</sub> = 15V, V <sub>IN</sub> = 0V		-0.3		-10 <sup>-5</sup>	-0.3		-1.0	μA
		V <sub>DD</sub> = 15V, V <sub>IN</sub> = 15V		0.3		10 <sup>-5</sup>	0.3		1.0	μA

**Note 1:** "Absolute Maximum Ratings" are those values beyond which the safety of the device cannot be guaranteed, they are not meant to imply that the devices should be operated at these limits. The table of "Recommended Operating Conditions" and "Electrical Characteristics" provides conditions for actual device operation.

**Note 2:** V<sub>SS</sub> = 0V unless otherwise specified.

**Note 3:** I<sub>OL</sub> and I<sub>OH</sub> are tested one output at a time.

## AC Electrical Characteristics\*

T<sub>A</sub> = 25°C, C<sub>L</sub> = 50 pF, R<sub>L</sub> = 200k, t<sub>rCL</sub> and t<sub>fCL</sub> = 20 ns, unless otherwise specified

Symbol	Parameter	Conditions	Min	Typ	Max	Units
<b>CLOCK OPERATION</b>						
t <sub>PHL</sub> , t <sub>PLH</sub>	Propagation Delay Time Carry Out Line	V <sub>DD</sub> = 5V		415	800	ns
		V <sub>DD</sub> = 10V		160	320	ns
		V <sub>DD</sub> = 15V		130	250	ns
	Carry Out Line	V <sub>DD</sub> = 5V	} C <sub>L</sub> = 15 pF	240	480	ns
V <sub>DD</sub> = 10V		85		170	ns	
V <sub>DD</sub> = 15V		70		140	ns	
	Decode Out Lines	V <sub>DD</sub> = 5V		500	1000	ns
V <sub>DD</sub> = 10V			200	400	ns	
V <sub>DD</sub> = 15V			160	320	ns	
t <sub>TLH</sub> , t <sub>THL</sub>	Transition Time Carry Out and Decode Out Lines t <sub>TLH</sub>	V <sub>DD</sub> = 5V		200	360	ns
		V <sub>DD</sub> = 10V		100	180	ns
		V <sub>DD</sub> = 15V		80	130	ns
	t <sub>THL</sub>	V <sub>DD</sub> = 5V		100	200	ns
		V <sub>DD</sub> = 10V		50	100	ns
		V <sub>DD</sub> = 15V		40	80	ns
f <sub>CL</sub>	Maximum Clock Frequency	V <sub>DD</sub> = 5V	} Measured with Respect to Carry Output Line	1.0	2	MHz
		V <sub>DD</sub> = 10V		2.5	5	MHz
		V <sub>DD</sub> = 15V		3.0	6	MHz
t <sub>WL</sub> , t <sub>WH</sub>	Minimum Clock Pulse Width	V <sub>DD</sub> = 5V		125	250	ns
		V <sub>DD</sub> = 10V		45	90	ns
		V <sub>DD</sub> = 15V		35	70	ns
t <sub>rCL</sub> , t <sub>fCL</sub>	Clock Rise and Fall Time	V <sub>DD</sub> = 5V			20	μs
		V <sub>DD</sub> = 10V			15	μs
		V <sub>DD</sub> = 15V			5	μs
t <sub>SU</sub>	Minimum Clock Inhibit Data Setup Time	V <sub>DD</sub> = 5V		120	240	ns
		V <sub>DD</sub> = 10V		40	80	ns
		V <sub>DD</sub> = 15V		32	65	ns
C <sub>IN</sub>	Average Input Capacitance			5	7.5	pF

## AC Electrical Characteristics\*

T<sub>A</sub> = 25°C, C<sub>L</sub> = 50 pF, R<sub>L</sub> = 200k, t<sub>rCL</sub> and t<sub>fCL</sub> = 20 ns, unless otherwise specified

Symbol	Parameter	Conditions	Min	Typ	Max	Units
<b>RESET OPERATION</b>						
t <sub>PHL</sub> , t <sub>PLH</sub>	Propagation Delay Time Carry Out Line	V <sub>DD</sub> = 5V		415	800	ns
		V <sub>DD</sub> = 10V		160	320	ns
		V <sub>DD</sub> = 15V		130	250	ns
	Carry Out Line	V <sub>DD</sub> = 5V	} C <sub>L</sub> = 15 pF	240	480	ns
		V <sub>DD</sub> = 10V		85	170	ns
		V <sub>DD</sub> = 15V		70	140	ns
	Decode Out Lines	V <sub>DD</sub> = 5V		500	1000	ns
		V <sub>DD</sub> = 10V		200	400	ns
		V <sub>DD</sub> = 15V		160	320	ns
t <sub>w</sub>	Minimum Reset Pulse Width	V <sub>DD</sub> = 5V		200	400	ns
		V <sub>DD</sub> = 10V		70	140	ns
		V <sub>DD</sub> = 15V		55	110	ns
t <sub>REM</sub>	Minimum Reset Removal Time	V <sub>DD</sub> = 5V		75	150	ns
		V <sub>DD</sub> = 10V		30	60	ns
		V <sub>DD</sub> = 15V		25	50	ns

\*AC Parameters are guaranteed by DC correlated testing.

## Timing Diagrams

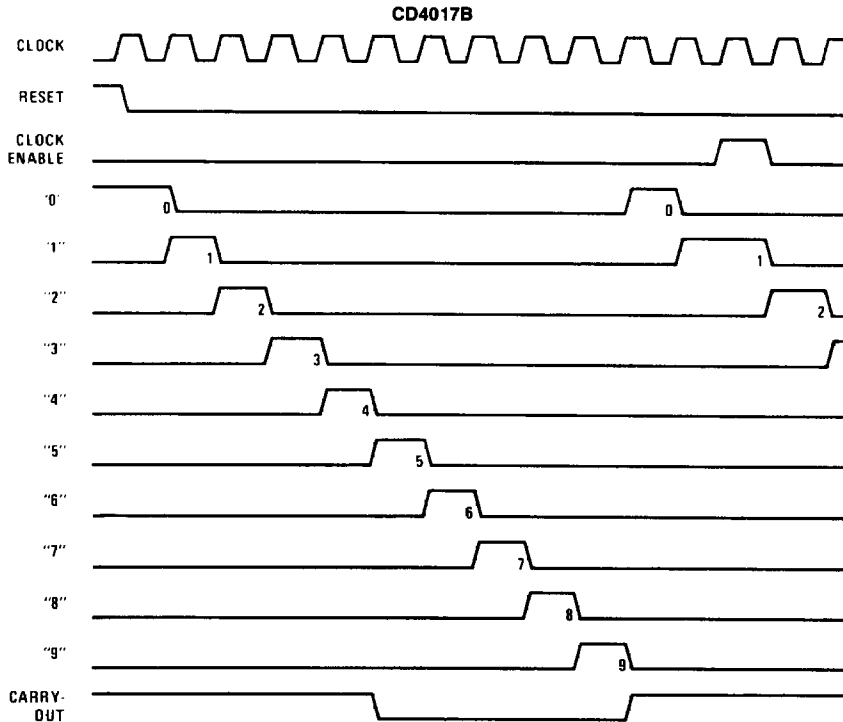

TL/F/5950-3

Logic Diagrams

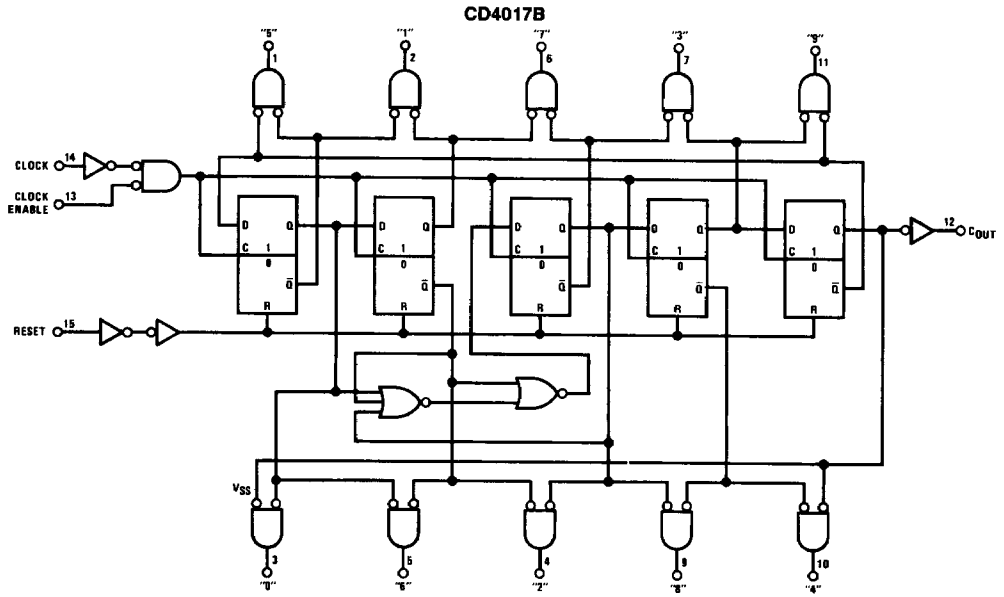

Terminal No. 8 = GND  
Terminal No. 16 = V<sub>DD</sub>

TL/F/5950-5

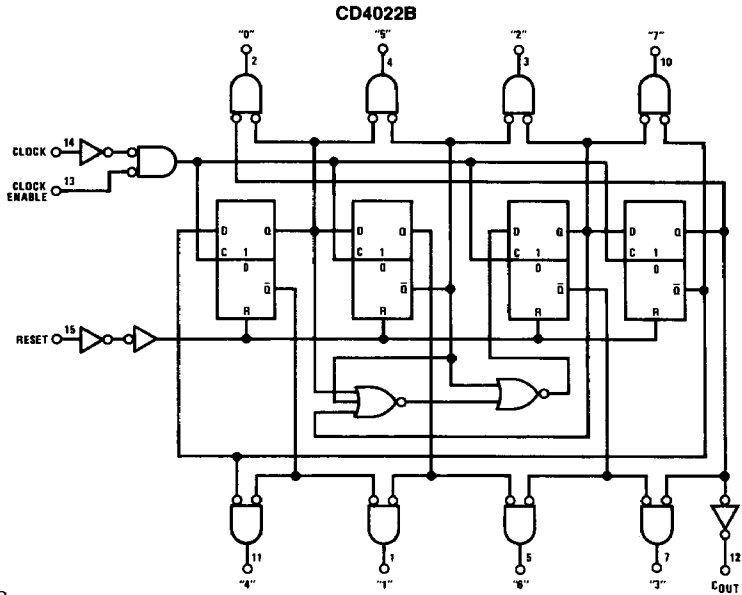

Terminal No. 16 = V<sub>DD</sub>  
Terminal No. 8 = GND

TL/F/5950-6