



Features

- ☑ *Designed for ATM/SONET/SDH at OC-3/STM-1 & OC-12/STM-4; FDDI & Fast Ethernet (100-FX) & Fibre Channel (266 Mbaud)*
- ☑ *Multi-sourced 1x9 package style*
- ☑ *Duplex SC or ST or FC connector*
- ☑ *- 40°C to +85°C option available*
- ☑ *Single +5 V supply & PECL interface*
- ☑ *Conductive Plastic or Metal package*
- ☑ *Wave Solder & Aqueous Wash Process Compatible*
- ☑ *Low cost option for shorter link distances*

Description

The DTR fiber optic transceivers offer a simple, convenient way to interface your ATM/SONET/SDH, FDDI, Fast Ethernet, or Fibre Channel boards to multimode fiber optic cables at 1300 nm wavelength.

The transmitter incorporates a highly reliable InGaAsP surface-emitting LED and a driver circuit which converts Pseudo Emitter Coupled Logic (PECL) data to light. The receiver incorporates an InGaAs PIN photodiode converting the light signal into an electrical current which is amplified and regenerated into PECL-compatible data. A PECL Signal Detect status output is also provided.

The transceiver is housed in a PCI-mezzanine-compliant (9.8 mm maximum height) one-row, 9-pin (1x9) package with Duplex SC connector interface. The transceiver package is made of *conductive* plastic to obtain excellent EMI shielding. An optional EMI shield for making direct

contact from the SC connector to the equipment chassis opening is also available for enhanced EMI performance. The transceiver is compatible with standard PCB production process (i.e. wave solder and aqueous wash compatible). The transceiver is also offered in a metal package with ST or FC connector interface.

The transceiver operates from a single +5V power supply over an operating temperature range of 0°C to +70°C. A high performance version with an operating temperature range of - 40°C to +85°C (“A” option) is also offered. Several versions are available for ATM/SONET/SDH applications at OC-3/STM-1(156 Mb/s) & OC-12/STM-4 (622Mb/s), Fast Ethernet (100 Base FX) & FDDI applications at 125 Mbaud, and Fibre Channel applications at 266 Mbaud. The DTR-RC module is a reduced cost alternative for applications with shorter link distances.

Fast Ethernet & FDDI Transceiver: DTR-125

Transmitter Performance Characteristics (over Operating Temperature, $V_{CC} = 4.75$ to $5.25V$)

Parameter	Symbol	Minimum	Typical	Maximum	Units
Data Rate	B	DC	125	266	Mb/s
Optical Output Power ¹	P_o	- 19.0	- 16.0	- 14.0	dBm
Center Wavelength ²	λ_c	1270	-	1380	nm
Spectral Width (FWHM) ²	$\Delta\lambda_{FWHM}$	-	140	-	nm
Optical Rise and Fall Time (10% to 90%) ²	t_r, t_f	0.6	-	3.5	ns
Extinction Ratio	P_{hi}/P_{lo}	10	-	-	dB
Transmitter OFF Power (continuous logic LOW input)	P_{OFF}	-	-	- 45.0	dBm
Random Jitter (peak-to-peak)	RJ	-	-	0.76	ns
Duty Cycle Distortion (peak-to-peak)	DCD	-	-	0.6	ns
Data Dependent Jitter (peak-to-peak)	DDJ	-	-	0.6	ns

¹ Measured average power coupled into 62.5/125 μ m, 0.275 NA graded-index multimode fiber.
² The minimum power specified is at Beginning-of-Life (BOL).
² Center wavelength, spectral width and rise/fall time are compliant with Figure 5.1 of the FDDI PMD specifications.

Receiver Performance Characteristics (over Operating Temperature, $V_{CC} = 4.75$ to $5.25V$)

Parameter	Symbol	Minimum	Typical	Maximum	Units
Data Rate	B	20	125	266	Mb/s
Minimum Input Optical Power (2.5×10^{-10} BER) ¹	FDDI Test ²	- 31.0	- 33.0	-	dBm
	$2^7 - 1$ PRBS ³	- 32.5	- 34.5	-	
Maximum Input Optical Power (2.5×10^{-10} BER) ¹	P_{max}	- 14.0	- 12.0	-	dBm
Signal Detect Thresholds	Increasing Light Input	P_{sd+}	-	- 31.0	dBm
	Decreasing Light Input	P_{sd-}	- 45.0	-	dBm
Signal Detect Hysteresis		1.5	-	-	dB
Signal Detect Timing Delay	Increasing Light Input	t_{sd+}	-	100	μ s
	Decreasing Light Input	t_{sd-}	-	350	
Wavelength of Operation	λ	1100	-	1600	nm

¹ Specified in Average Optical Input Power and measured at 1300 nm wavelength and 125 Mbaud.
² Worst Case FDDI Test Conditions.
³ When tested with $2^7 - 1$ Pseudo Random Binary Sequence with optical input rise/fall time of 2.5 ns and optimum sampling.

Low Cost Fast Ethernet & FDDI Transceiver: DTR-125-RC

Performance Characteristics (over Operating Temperature, $V_{CC} = 4.75$ to $5.25V$)

Transmitter Parameter		Symbol	Minimum	Typical	Maximum	Units
Optical Output Power ¹		P_o	- 21.0	- 18.0	- 14.0	dBm
Spectral Width (FWHM)		$\Delta\lambda_{FWHM}$	-	-	250	nm
Optical Rise and Fall Time (10% to 90%)		t_r, t_f	-	-	4.0	ns

¹ Measured average power coupled into 62.5/125 μ m, 0.275 NA graded-index multimode fiber.
 The minimum power specified is at Beginning-of-Life (BOL).

Receiver Parameter		Symbol	Minimum	Typical	Maximum	Units
Minimum Input Optical Power (2.5×10^{-10} BER) ¹	FDDI Test ²	P_{min}	- 29.0	- 31.0	-	dBm
	$2^7 - 1$ PRBS ³		- 30.5	- 32.5	-	
Signal Detect Thresholds	Increasing Light Input	P_{sd+}	-	-	- 29.0	dBm

^{1,2 & 3} All three notes are the same as in the DTR-125 Receiver specifications.

All other performance parameters are the same as DTR-125 Transceivers.

ATM OC-3/STM-1 Transceiver: DTR-156

Transmitter Performance Characteristics (over Operating Temperature, $V_{CC} = 4.75$ to $5.25V$)

Parameter	Symbol	Minimum	Typical	Maximum	Units
Data Rate	B	DC	156	266	Mb/s
Optical Output Power ¹	P_o	- 19.0	- 16.0	- 14.0	dBm
Center Wavelength	λ_c	1270	-	1380	nm
Spectral Width (FWHM)	$\Delta\lambda_{FWHM}$	-	-	200	nm
Optical Rise and Fall Time (10% to 90%)	t_r, t_f	-	2.0	3.0	ns
Extinction Ratio	P_{hi}/P_{lo}	10	-	-	dB
Transmitter OFF Power (continuous logic LOW input)	P_{OFF}	-	-	- 45.0	dBm
Random Jitter (peak-to-peak)	RJ	-	-	0.52	ns
Duty Cycle Distortion (peak-to-peak)	DCD	-	-	0.6	ns

¹ Measured average power coupled into 62.5/125 μm , 0.275 NA graded-index multimode fiber.
The minimum power specified is at Beginning-of-Life (BOL).

Receiver Performance Characteristics (over Operating Temperature, $V_{CC} = 4.75$ to $5.25V$)

Parameter	Symbol	Minimum	Typical	Maximum	Units
Data Rate	B	50	156	266	Mb/s
Receiver Sensitivity (2.5×10^{-10} BER) ¹	P_{min}	- 30.0	- 33.0	-	dBm
Maximum Input Optical Power (2.5×10^{-10} BER) ¹	P_{max}	- 14.0	- 12.0	-	dBm
Signal Detect Thresholds	Increasing Light Input	P_{sd+}	-	- 30.0	dBm
	Decreasing Light Input	P_{sd-}	- 45.0	-	
Signal Detect Hysteresis		1.0	-	-	dB
Signal Detect Timing Delay	Increasing Light Input	t_{sd+}	-	100	μs
	Decreasing Light Input	t_{sd-}	-	350	
Wavelength of Operation	λ	1100	-	1600	nm

¹ Specified in Average Optical Input Power and measured at 156 Mb/s and 1300 nm wavelength with $2^{23}-1$ PRBS and a minimum eye opening of 1.7 ns.

Low Cost ATM OC-3/STM-1 Transceiver: DTR-156-RC

Performance Characteristics (over Operating Temperature, $V_{CC} = 4.75$ to $5.25V$)

Transmitter Parameter		Symbol	Minimum	Typical	Maximum	Units
Optical Output Power ¹		P_o	- 21.0	- 18.0	- 14.0	dBm
Spectral Width (FWHM)		$\Delta\lambda_{FWHM}$	-	-	250	nm
Optical Rise and Fall Time (10% to 90%)		t_r, t_f	-	-	4.0	ns

¹ Measured average power coupled into 62.5/125 μm , 0.275 NA graded-index multimode fiber.
The minimum power specified is at Beginning-of-Life (BOL).

Receiver Parameter		Symbol	Minimum	Typical	Maximum	Units
Minimum Input Optical Power (2.5×10^{-10} BER) ¹		P_{min}	- 29.0	- 32.0	-	dBm
Signal Detect Thresholds	Increasing Light Input	P_{sd+}	-	-	- 29.0	dBm

¹ same as note #1 in the DTR-156 Receiver specifications.

All other performance parameters are the same as DTR-156 Transceivers.

266 Mb/s Fibre Channel Transceiver: DTR-266

Transmitter Performance Characteristics (over Operating Temperature, $V_{CC} = 4.75$ to $5.25V$)

Parameter	Symbol	Minimum	Typical	Maximum	Units
Data Rate	B	DC	266	320	Mb/s
Optical Output Power ¹	P_o	- 19.0	- 16.0	- 14.0	dBm
Center Wavelength	λ_c	1270	-	1380	nm
Spectral Width (FWHM)	$\Delta\lambda_{FWHM}$	-	-	200	nm
Optical Rise and Fall Time (10% to 90%)	t_r, t_f	-	-	2.2	ns
Extinction Ratio	P_{hi}/P_{lo}	10	-	-	dB
Transmitter OFF Power (continuous logic LOW input)	P_{OFF}	-	-	- 45.0	dBm
Random Jitter (peak-to-peak)	RJ	-	-	0.5	ns
Duty Cycle Distortion (peak-to-peak)	DCD	-	-	0.6	ns
Data Dependent Jitter ((peak-to-peak)	DDJ	-	-	0.5	ns
¹ Measured average power coupled into 62.5/125 μ m, 0.275 NA graded-index multimode fiber. The minimum power specified is at Beginning-of-Life (BOL).					

Receiver Performance Characteristics (over Operating Temperature, $V_{CC} = 4.75$ to $5.25V$)

Parameter	Symbol	Minimum	Typical	Maximum	Units
Data Rate	B	20	266	320	Mb/s
Receiver Sensitivity (2.5×10^{-10} BER) ¹	P_{min}	- 28.0	- 30.0	-	dBm
Maximum Input Optical Power (2.5×10^{-10} BER) ¹	P_{max}	- 14.0	- 12.0	-	dBm
Signal Detect Thresholds	Increasing Light Input	P_{sd+}	-	-	- 28.0
	Decreasing Light Input	P_{sd-}	- 45.0	-	-
Signal Detect Hysteresis	-	1.0	-	-	dB
Signal Detect Timing Delay	Increasing Light Input	t_{sd+}	-	-	100
	Decreasing Light Input	t_{sd-}	-	-	350
Wavelength of Operation	λ	1100	-	1600	nm
¹ Specified in Average Optical Input Power and measured at 266 Mb/s and 1300 nm wavelength with 2 ⁷ -1 PRBS.					

ATM OC-12/STM-4 Transceiver: DTR-622

Transmitter Performance Characteristics (over Operating Temperature, $V_{CC} = 4.75$ to $5.25V$)

Parameter	Symbol	Minimum	Typical	Maximum	Units
Data Rate	B	DC	622	700	Mb/s
Optical Output Power ¹	P_o	- 20.0	- 18.0	- 14.0	dBm
Center Wavelength	λ_c	1270	-	1380	nm
Spectral Width (FWHM)	$\Delta\lambda_{FWHM}$	-	140	200	nm
Optical Rise and Fall Time (10% to 90%)	t_r, t_f	-	1.0	1.25	ns
Extinction Ratio	P_{hi}/P_{lo}	10	-	-	dB
Random Jitter (peak-to-peak)	RJ	-	-	0.13	ns
Duty Cycle Distortion (peak-to-peak)	DCD	-	-	0.4	ns

¹ Measured average power coupled into 62.5/125 μm , 0.275 NA graded-index multimode fiber.
The minimum power specified is at Beginning-of-Life (BOL).

Receiver Performance Characteristics (over Operating Temperature, $V_{CC} = 4.75$ to $5.25V$)

Parameter	Symbol	Minimum	Typical	Maximum	Units
Data Rate	B	50	622	700	Mb/s
Receiver Sensitivity (10^{-10} BER) ¹	P_{min}	- 26.0	- 28.0	-	dBm
Maximum Input Optical Power (10^{-10} BER) ¹	P_{max}	- 14.0	- 12.0	-	dBm
Signal Detect Thresholds	Increasing Light Input	P_{sd+}	-	-	- 26.0
	Decreasing Light Input	P_{sd-}	- 40.0	-	-
Signal Detect Hysteresis		-	1.0	-	dB
Signal Detect Timing Delay	Increasing Light Input	t_{sd+}	-	-	100
	Decreasing Light Input	t_{sd-}	-	-	350
Wavelength of Operation	λ	1100	-	1600	nm

¹ Specified in Average Optical Input Power and measured at 622 Mb/s and 1300 nm wavelength with $2^{23}-1$ PRBS and a minimum eye opening of 0.31 ns.

Low Cost ATM OC-12/STM-4 Transceiver: DTR-622-RC

Performance Characteristics (over Operating Temperature, $V_{CC} = 4.75$ to $5.25V$)

Transmitter Parameter	Symbol	Minimum	Typical	Maximum	Units
Optical Output Power ¹	P_o	- 22.0	- 20.0	- 14.0	dBm
Optical Rise and Fall Time (10% to 90%)	t_r, t_f	-	1.2	1.6	ns

¹ Measured average power coupled into 62.5/125 μm , 0.275 NA graded-index multimode fiber.
The minimum power specified is at Beginning-of-Life (BOL).

All other performance parameters are the same as DTR-622 Transceivers.

DTR Multimode Transceivers

Absolute Maximum Ratings

Parameter		Symbol	Minimum	Maximum	Units
Storage Temperature		T_{st}	- 40	+ 85	°C
Operating Temperature	"A" option	T_{op}	- 40	+ 85	°C
	"blank" option		0	+ 70	
Supply Voltage		V_{CC}	- 0.5	+ 6.0	V
Input Voltage		V_{in}	- 0.5	V_{CC}	V
Output Current		I_O	-	50	mA
Lead Soldering Temperature & Time		-	-	260°C, 10 sec	

Transmitter Electrical Interface (over Operating Temperature Range)

Parameter	Symbol	Minimum	Typical	Maximum	Units
Input HIGH Voltage	V_{IH}	$V_{CC} - 1.165$	-	$V_{CC} - 0.700$	V
Input LOW Voltage	V_{IL}	$V_{CC} - 1.890$	-	$V_{CC} - 1.475$	V
Data Input Current - HIGH	I_H	-	-	350	μA
Data Input Current - LOW	I_L	-	-	250	μA

Receiver Electrical Interface (over Operating Temperature Range)

Parameter	Symbol	Minimum	Typical	Maximum	Units
Output HIGH Voltage	V_{OH}	$V_{CC} - 1.080$	-	$V_{CC} - 0.700$	V
Output LOW Voltage	V_{OL}	$V_{CC} - 1.950$	-	$V_{CC} - 1.595$	V
Output Current	I_O	-	-	25	mA

Electrical Power Supply Characteristics (over Operating Temperature Range)

Parameter		Symbol	Minimum	Typical	Maximum	Units
Supply Voltage		V_{CC}	4.75	5.0	5.25	V
Supply Current	622 Mb/s module	TX	I_{CC}	110	150	mA
		RX	I_{CC}	70	110	mA
	all others	TX	I_{CC}	95	120	mA
		RX	I_{CC}	55	70	mA

Related Products for Multimode Fiber Applications

DTR-xxx-3.3: 3.3 volt version of the DTR-xxx Multimode Transceivers

DTC-03-MM: OC-3/STM-1 1300 nm LED-based Transceivers with Clock Recovery (2x9 package)

DTC-12-MM: OC-12/STM-4 1300 nm LED-based Transceivers with Clock Recovery (2x9 package)

DTR-1250-MM: Gigabit Ethernet 850 nm VCSEL Transceivers (1x9 package)

DTR-1062-MM: 1.062 Gbaud Fibre Channel 850 nm VCSEL Transceivers (1x9 package)

FDL-TX & FDL-RX: Conductive Plastic Transmitter & Receiver Modules for OC-1,
OC-3/STM-1 & FDDI/Fast Ethernet (16-PIN DIP package)

DTL-TX & DTL-RX: Hermetically sealed Transmitter & Receiver Modules for OC-1,
OC-3/STM-1 & FDDI/Fast Ethernet (16-PIN DIP package)

DTR Multimode Transceivers

Application Notes

Transmitter: When the DATA+ input is at logic HIGH and DATA- input is at logic LOW, the LED is ON; and vice versa. In single-ended applications, the unused input pin should be biased to $V_{CC} - 1.29$ V.

Receiver: Both differential DATA+ and DATA- outputs are PECL levels requiring termination (50 ohms to $V_{CC} - 2$ volts or 510 ohms to GND is recommended). For optimum performance, both outputs should be terminated in the same manner, even if only one is used.

The Signal Detect circuit monitors the level of the incoming optical signal and generates a logic LOW signal when insufficient photocurrent is produced. The SIGNAL DETECT output is PECL level requiring termination (510 ohms to GND

is recommended).

Interface circuit: The power supply line should be well-filtered. All 0.1 μ F power supply bypass capacitors should be as close to the DTR transceiver module as possible. The two front GND posts should be grounded to Circuit Ground or Chassis Ground. The termination resistors for the transmitter should be close to the DTR transceiver module. The termination resistors for the receiver should be close to the PHY or SERDES device (which receives the DATA outputs from the receiver).

If the receiver outputs drive long traces or multiple loads, the use of an ECL buffer gate to isolate the receiver from transmission line reflections is recommended.

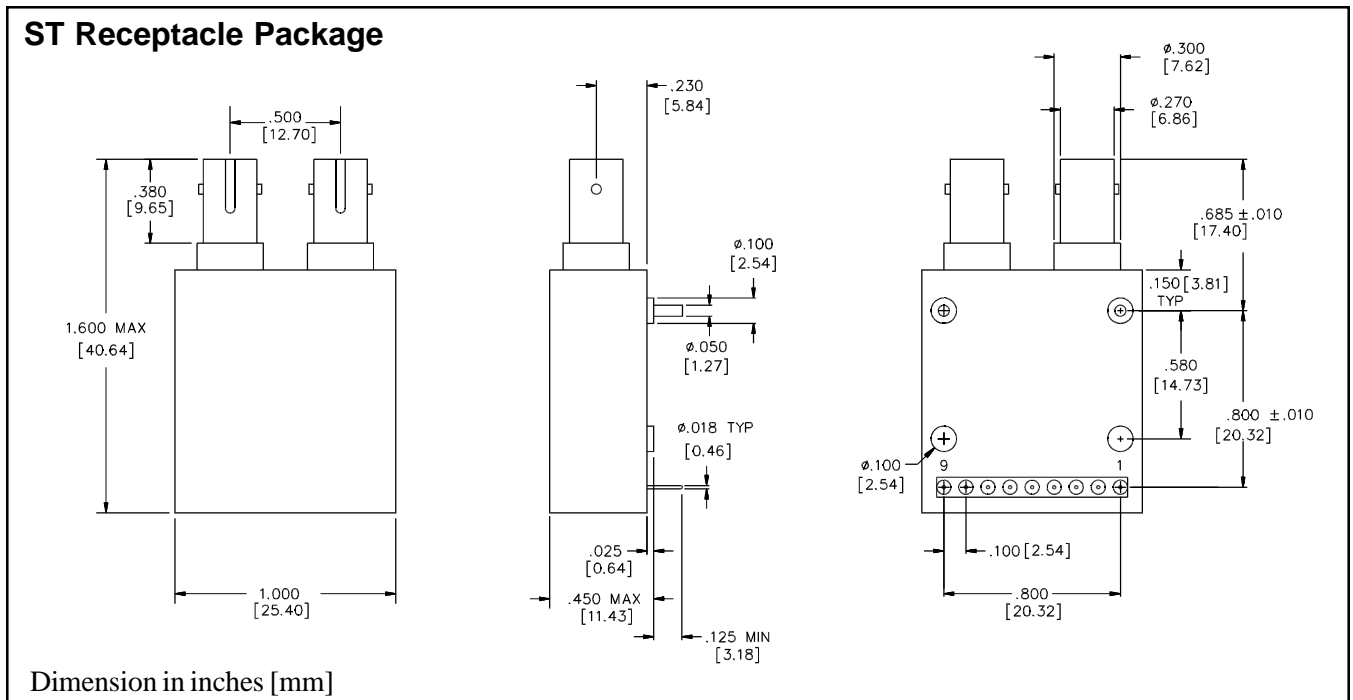
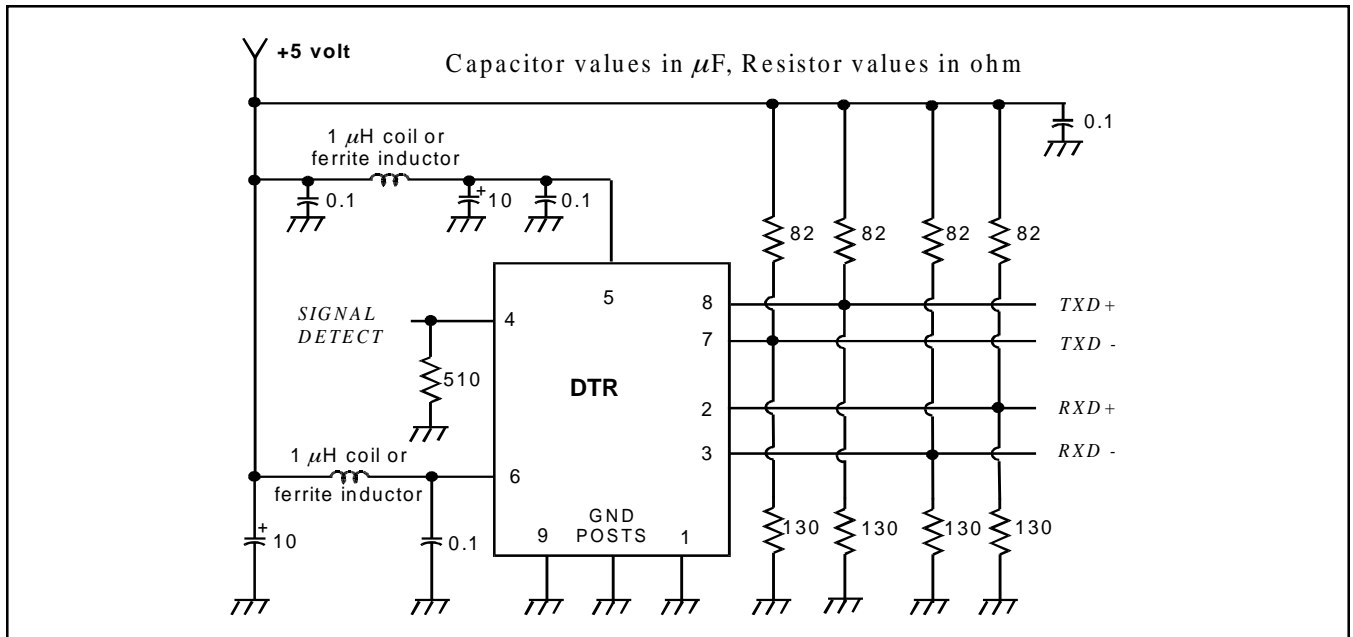

DTR Multimode Transceivers

FC Receptacle Package

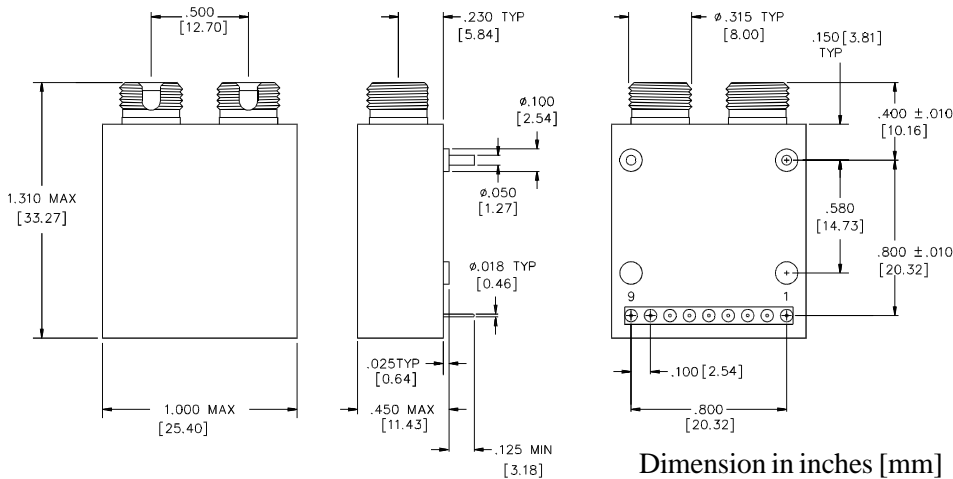

Pin Assignments

PIN	FUNCTION
1	RX GND
2	RD+ (RX DATA OUT +)
3	RD- (RX DATA OUT -)
4	SD (RX SIGNAL DETECT)
5	V _{CC} RX
6	V _{CC} TX
7	TD- (TX DATA IN -)
8	TD+ (TX DATA IN +)
9	TX GND

Duplex SC Receptacle Package

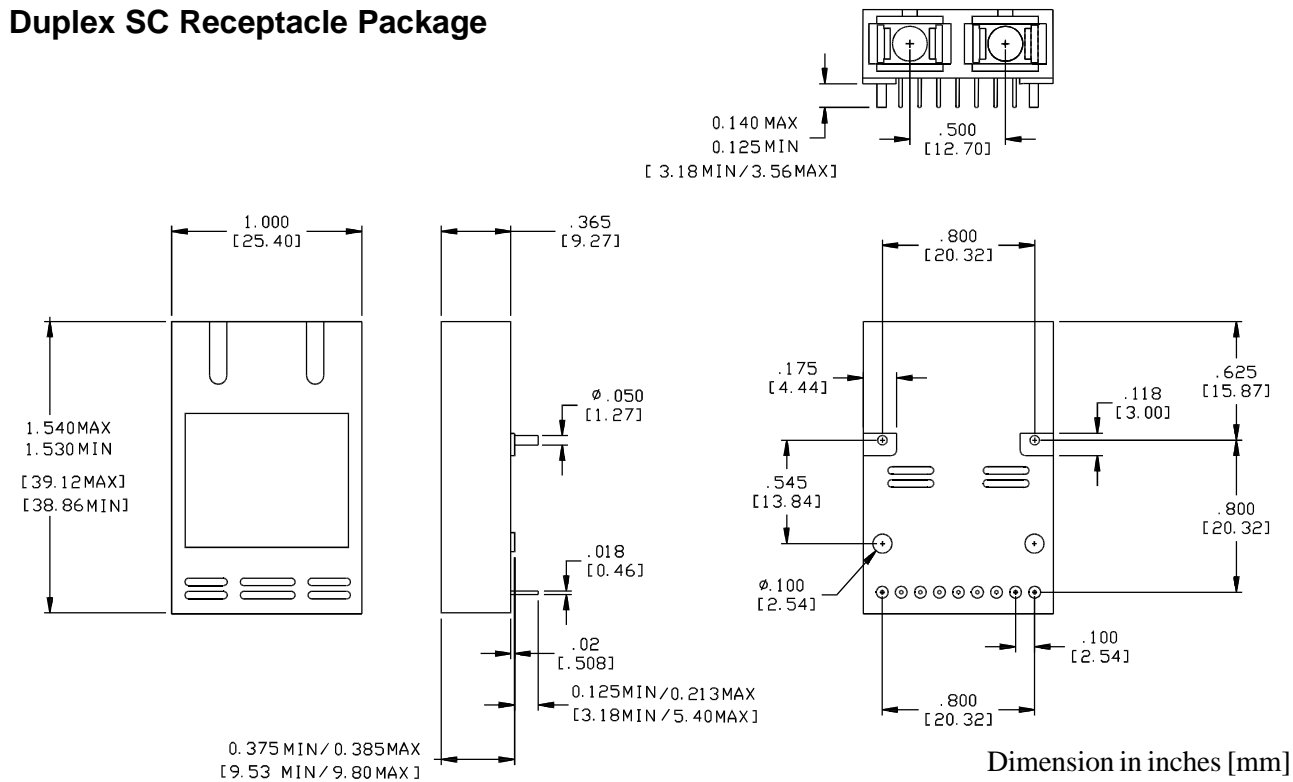

Ordering Information

DTR - XXX - YY - T or DTR - XXX - RC - YY - T

Data Rate (Application)

125: FDDI/Fast Ethernet
 156: OC-3/STM-1
 266: Fibre Channel
 622: OC-12/STM-4

Receptacle

“Blank”: SC Receptacle
 ST : ST Receptacle
 FC : FC Receptacle

Temperature Range

“Blank”: 0°C to +70°C
 A : -40°C to +85°C

Optical Communication Products, Inc.

9736 Eton Avenue, Chatsworth, CA 91311, Tel.: 818-701-0164, FAX: 818-701-1468

Optical Communication Products, Inc. reserves the right to make changes in equipment design or specifications without notice. Information supplied by Optical Communication Products, Inc. is believed to be accurate and reliable. However, no responsibility is assumed by Optical Communication Products, Inc. for its use nor for any infringements of third parties which may result from its use. No license is granted by implication or otherwise under any patent right of Optical Communication Products, Inc.

21737-0300, Rev. F

Contents

Description	1
Fast Ethernet & FDDI Transceiver: DTR-125	2
Low Cost Fast Ethernet & FDDI Transceiver: DTR-125-RC	2
ATM OC-3/STM-1 Transceiver: DTR-156	3
Low Cost ATM OC-3/STM-1 Transceiver: DTR-156-RC	3
266 Mb/s Fibre Channel Transceiver: DTR-266	4
ATM OC-12/STM-4 Transceiver: DTR-622	5
Low Cost ATM OC-12/STM-4 Transceiver: DTR-622-RC	5
Absolute Maximum Ratings	6
Transmitter Electrical Interface	6
Receiver Electrical Interface	6
Electrical Power Supply Characteristics	6
Application Notes	7
ST Receptacle Package	7
FC Receptacle Package	8
Duplex SC Receptacle Package	8
Ordering Information	8