

## Datasheet - Preliminary Specification

### Features

- 10-bit Resolution ADC
- 2.2 Gsps Sampling Rate
- Ascending Compatibility with e2v AT84AS008 10-bit 2.2 Gsps ADC
- 500 mVpp Full-scale Analog Input Range
- 100 $\Omega$  Differential or 50 $\Omega$  Single-ended Analog input and Clock Input
- LVDS Output Compatibility
- Functions:
  - ADC Gain Adjust and Sampling Delay Adjust
  - Data Ready Output with Asynchronous Reset
  - Out-of-range Output Bit
- Power Consumption: 4.0W
- Power supplies:
  - Analog: -2.2V, 3.3V
  - Digital: + 2.5V
- Radiation Tolerant
- Package: CBGA152 and CI-CGA 152 Cavity Down Hermetic Package
- Evaluation Board EV10AS008BGL-EB
- Companion Device:
  - DMUX 10-bit 1:2/1:4 LVDS 2.2 Gsps AT84CS001

### Performances

- 3.8 GHz Full Power Input Bandwidth (-3 dB)
- Gain Flatness:  $\pm 0.25$  dB (from DC up to 1.5 GHz)
- Low Input VSWR: 1.2 Maximum from DC to 2.5 GHz
- Single Tone Performances (-1 dBFS):
  - SFDR = -61 dBc; 8.0 ENOB; SNR = 52 dBc at  $F_S = 1.7$  Gsps,  $F_{IN} = 850$  MHz
  - SFDR = -57 dBc; 7.6 ENOB; SNR = 50 dBc at  $F_S = 2.2$  Gsps,  $F_{IN} = 1.1$  GHz
  - SFDR = -53 dBc; 7.4 ENOB; SNR = 48 dBc at  $F_S = 2.2$  Gsps,  $F_{IN} = 2$  GHz
- Dual Tone Performances (IMD3),  $F_S = 1.7$  Gps, (-7 dBFS tone):
  - (Fin1 = 995 MHz, Fin2 = 1005 MHz): IMD3 = 60 dBFS
  - (Fin1 = 1545 MHz, Fin2 = 1555 MHz): IMD3 = 60 dBFS
  - (Fin1 = 1945 MHz, Fin2 = 1955 MHz): IMD3 = 59 dBFS
- Low Bit Error Rate ( $10^{-15}$ ) at 2.2 Gsps

### Screening

- Temperature Range for Packaged Device:
  - 0 $^{\circ}$ C <  $T_C$ ;  $T_J$  < 90 $^{\circ}$ C (Commercial C Grade)
  - -20 $^{\circ}$ C <  $T_C$ ;  $T_J$  < 110 $^{\circ}$ C (Industrial V Grade)
  - -55 $^{\circ}$ C <  $T_C$ ;  $T_J$  < 125 $^{\circ}$ C (Military M Grade)

Visit our website: [www.e2v.com](http://www.e2v.com)  
for the latest version of the datasheet

## Applications

- Broadband Direct RF Down Conversion
- Wide Band Satellite Receivers
- Phased Array Antennas, Radars and ECM
- High-speed Instrumentation and High-speed Acquisition Systems
- High Energy Physics
- Automatic Test Equipment

## 1. Description

The EV10AS008B 10-bit 2.2 Gsps ADC allows accurate digitization of high frequency signals thanks to the 3.8 GHz analog input bandwidth.

The innovative design of the on-chip Track and Hold (T/H) and digitizing core lead to unprecedented dynamic performance at a sampling rate of 2.2 Gsps (over the full first and second Nyquist zone).

The EV10AS008B features an enhanced spectral purity and very low noise floor, independent on frequency and temperature. It is particularly well suited for performance enhancement (that is dithering).

Figure 1-1. Block Diagram

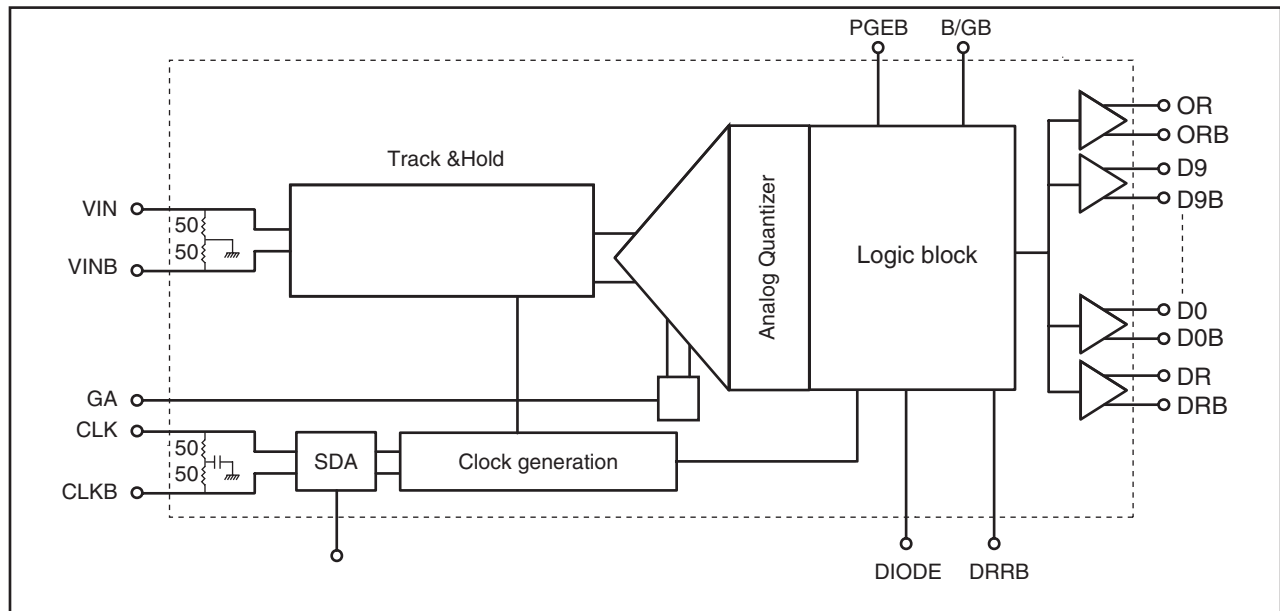

## 1.1 Ascending Compatibility with AT84AS008

The EV10AS008B is fully compatible to the AT84AS008 in terms of pinout and functionality. The EV10AS008B is supplied with +3.3V, -2.2V, +2.5V instead of +5V, -5V, +1.45V. The digital control inputs (DRRB, PGEB, SDA, SDAEN, BGB) are activated on logic high. The digital control inputs are inactive when grounded or floating same as for the AT84AS008.

Table 1-1 summarizes the differences between EV10AS008B and AT84AS008.

**Table 1-1.** EV10AS008B vs. AT84AS008

|                      |                        | AT84AS008                            | EV10AS008B       |
|----------------------|------------------------|--------------------------------------|------------------|
| Analog Power Supply  | $V_{CC}$               | +5V                                  | +3.3V            |
|                      | $V_{EE}$               | -5V                                  | -2.2V            |
| Digital Power Supply | $V_{PLUSD}$            | +1.45V                               | +2.5V            |
|                      | $D_{VEE}$              | -5V ( $D_{VEE}$ )                    | 0V (DGND)        |
| Digital inputs       | DRRB                   |                                      | LVTTL            |
|                      | B/GB, PGEB, SDAEN      | 0/-5V                                | LVTTL            |
| Output Buffer        | ECL                    | Yes                                  | No               |
|                      | LVDS                   | Yes                                  | Fully compatible |
| Analog Input         | $V_{IN}$ , $V_{INB}$   | Differential<br>(ground common mode) | Fully compatible |
| Clock input          | $V_{CLK}$ , $V_{CLKB}$ | Differential<br>(ground common mode) | Fully compatible |
| Power Consumption    |                        | 4.2W                                 | 4.0W             |

## 2. Functional Description

The EV10AS008B is a 10-bit 2.2 Gsps ADC. The device includes a front-end Track and Hold stage (T/H), followed by an analog encoding stage (Analog Quantizer) which outputs analog residues resulting from analog quantization. Successive banks of latches regenerate the analog residues into logical levels before entering an error correction circuitry and a resynchronization stage followed by LVDS compatible differential output buffers.

The EV10AS008B works in fully differential mode from analog inputs up to digital outputs. A differential data ready output (DR/DRB) is available for optimum data valid time window. Asynchronous data ready Reset ensures that the first digitized data is registered on rising edge of data ready output.

The Control pin B/GB (A11 of CBGA package) is provided to select either a binary or Gray data output format. The gain control pin GA (R9 of CBGA package) is provided to adjust the ADC gain transfer function. A Sampling Delay Adjust function (SDA) is provided to fine tune the ADC aperture delay, for applications requesting the interleaving of multiple ADCs for example SDA is enabled if SDAEN is active. A pattern generator is integrated on chip for debug or acquisition set-up. This function is enabled through the PGEB pin (A9 of CBGA package). An out-of-range bit (OR, ORB) indicates when the input overrides the ADC full-scale range. A die junction temperature monitoring function is available (A10 of CBGA package).

The EV10AS008B uses only vertical isolated NPN transistors together with oxide isolated polysilicon resistors, which allows enhanced radiation tolerance (over 100 kRad (Si) expected total dose). The EV10AS008B provides ascending compatibility with the AT84AS008.

## 3. Specifications

### 3.1 Absolute Maximum Ratings

Table 3-1. Absolute Maximum Ratings

| Parameter   | Symbol                   | Comments                   | Value       | Unit |
|---|--------------------------|----------------------------|-------------|------|
| Positive supply voltage                             | $V_{CC}$                 |                            | GND to 3.8  | V    |
| Digital positive supply voltage                     | $V_{PLUSD}$              |                            | GND to 3    | V    |
| Negative supply voltage                             | $V_{EE}$                 |                            | GND to -2.7 | V    |
| Analog input voltages (to ground)                   | $V_{IN}$ or $V_{INB}$    |                            | -1.5 to 1.5 | V    |
| Maximum difference between $V_{IN}$ and $V_{INB}$   | $V_{IN} - V_{INB}$       |                            | -1.5 to 1.5 | V    |
| Clock input voltage                                 | $V_{CLK}$ or $V_{CLKB}$  |                            | -1 to 1     | V    |
| Clock input common mode voltage                     | $(V_{CLK} + V_{CLKB})/2$ |                            | -0.7 to 0.6 | V    |
| Maximum difference between $V_{CLK}$ and $V_{CLKB}$ | $V_{CLK} - V_{CLKB}$     |                            | -1.5 to 1.5 | V    |
| Static input voltage                                | $V_D$                    | GA, SDA                    | -1 to 1     | V    |
| Digital input voltage                               | $V_D$                    | SDAEN, DRRB,<br>B/GB, PGEB | -0.5 to 3.8 | V    |
| Junction temperature                                | $T_J$                    |                            | 135         | °C   |

Note: Absolute maximum ratings are limiting values (referenced to GND = 0V), to be applied individually, while other parameters are within specified operating conditions. Long exposure to maximum rating may affect device reliability. All integrated circuits have to be handled with appropriate care to avoid damages due to ESD. Damage caused by inappropriate handling or storage could range from performance degradation to complete failure.  $D_{VEE}$  in AT84AS008 becomes DGND in EV10AS008B.

### 3.2 Recommended Conditions of Use

**Table 3-2.** Recommended Conditions of Use

| Parameter  | Symbol              | Comments  | Recommended   |  | Unit       |
|--|---------------------|---|---|--|------------|
| Positive supply voltage                            | $V_{CC}$            |   | 3.3   |  | V          |
| Positive digital supply voltage <sup>(Note.)</sup> | $V_{PLUSD}$         |   | 2.5   |  | V          |
| Negative supply voltages                           | $V_{EE}$            |   | -2.2  |  | V          |
| Differential analog input voltage (full-scale)     | $V_{IN} - V_{INB}$  | 100 $\Omega$ differential input   | $\pm 125$<br>500  |  | mV<br>mVpp |
| Clock input power level (ground common mode)       | $P_{CLK}, P_{CLKB}$ | 100 $\Omega$ differential clock   | 4   |  | dBm        |
| Operating temperature Range                        |                     | Commercial <i>C</i> grade<br>Industrial <i>V</i> grade<br>Military <i>M</i> grade | 0°C < $T_C$ ; $T_J$ < 90°C<br>- 20°C < $T_C$ ; $T_J$ < 110°C<br>-55°C < $T_C$ ; $T_J$ < 125°C |  | °C         |
| Storage temperature                                | Tstg                |   | - 65 to 150   |  | °C         |

Note: ADC performances are independent on  $V_{PLUSD}$  common mode voltage.

### 3.3 Electrical Characteristics

- $V_{CC} = 3.3V$ ;  $V_{EE} = -2.2V$ ,  $V_{PLUSD} = +2.5V$  (unless otherwise specified)
- $V_{IN} - V_{INB} = 500$  mVpp (full-scale differential Input). Clock inputs differential driven; analog-input differential driven

**Table 3-3.** Electrical Operating Characteristics

| Parameter  | Test Level | Symbol                | Min  | Typ  | Max  | Unit     |
|--|------------|-----------------------|------|------|------|----------|
| <b>Resolution</b>  |            |                       |      | 10   |      | Bits     |
| <b>Power Requirements</b>  |            |                       |      |      |      |          |
| Power supply voltage   |            |                       |      |      |      |          |
| - analog   | 1          | $V_{CC}$              | 3.15 | 3.3  | 3.45 | V        |
| - digital (LVDS)   | 4          | $V_{PLUSD}$           | 2.4  | 2.5  | 2.6  | V        |
| Power supply current   |            |                       |      |      |      |          |
| - analog   | 1          | $I_{VCC}$             |      | 900  | 980  | mA       |
| - digital  | 1          | $I_{VPLUSD}$          |      | 160  | 180  | mA       |
| Negative supply voltage  |            |                       |      |      |      |          |
| - analog   | 1          | $V_{EE}$              | -2.3 | -2.2 | -2.1 | V        |
| Negative supply current  |            |                       |      |      |      |          |
| - analog   | 1          | $I_{VEE}$             |      | 270  | 290  | mA       |
| Power dissipation  | 1          | $P_D$                 |      | 4.0  | 4.5  | W        |
| <b>Analog Inputs</b>   |            |                       |      |      |      |          |
| Full-scale input voltage range (differential mode)<br>(0V common mode voltage)                                     | 4          | $V_{IN}$              | -125 |      | 125  | mV       |
|  | 4          | $V_{INB}$             | -125 |      | 125  | mV       |
| Full-scale input voltage range (single-ended input<br>option other input grounded)                                 | 4          | $V_{IN}$ or $V_{INB}$ | -250 |      | 250  | mV       |
|  | 4          |                       |      |      |      | mV       |
| Full-scale analog input power level<br>(differential mode, power in 100 $\Omega$ )                                 | 4          | $P_{IN, INB}$         |      | -5   |      | dBm      |
| Full-scale analog input power level<br>(single-ended input option other input grounded)<br>(power in 50 $\Omega$ ) | 4          | $P_{IN}$ or $P_{INB}$ |      | -2   |      | dBm      |
| Analog input capacitance (die)   | 4          | $C_{IN}$              |      | 0.3  |      | pF       |
| Input leakage current ( $V_{IN} = V_{INB} = 0V$ )  | 4          | $I_{IN}$              |      | 50   |      | $\mu A$  |
| Input resistance   |            |                       |      |      |      |          |
| - single-ended   | 4          | $R_{IN}$              | 49   | 50   | 51   | $\Omega$ |
| - differential   | 4          | $R_{IN, INB}$         | 98   | 100  | 102  | $\Omega$ |

Table 3-3. Electrical Operating Characteristics (Continued)

| Parameter  | Test Level                         | Symbol                     | Min       | Typ       | Max       | Unit     |
|--|------------------------------------|----------------------------|-----------|-----------|-----------|----------|
| <b>Clock inputs</b>  |                                    |                            |           |           |           |          |
| Clock inputs common voltage range ( $V_{CLK}$ or $V_{CLKB}$ )<br>(DC coupled clock input)<br>AC coupled for LVDS compatibility | 4                                  | $V_{CM}$                   | -0.4      | 0         | 0.3       | V        |
| Clock input power level (low-phase noise sinewave input) 100 $\Omega$ differential   | 4                                  | $P_{CLK, CLKB}$            | -1        | 1         | 4         | dBm      |
| Clock input power level (low-phase noise sinewave input) 50 $\Omega$ single ended  | 4                                  | $P_{CLK}$ or<br>$P_{CLKB}$ | -4        | 4         | 7         | dBm      |
| Clock input swing (differential voltage) on each clock input   | 4                                  | $V_{CLK}$ $V_{CLKB}$       | $\pm 100$ | $\pm 250$ | $\pm 354$ | mV       |
| Clock input swing (single ended; with CLKB = 50 $\Omega$ to GND)   | 4                                  | $V_{CLK}$                  | $\pm 200$ | $\pm 500$ | $\pm 708$ | mV       |
| Clock input capacitance (die)  | 4                                  | $C_{CLK}$                  |           | 0.3       |           | pF       |
| Clock input resistance   |                                    |                            |           |           |           |          |
| - single-ended   | 4                                  | $R_{CLK}$                  | 45        | 50        | 55        | $\Omega$ |
| - differential ended   | 4                                  | $R_{CLK, CLKB}$            | 90        | 100       | 110       | $\Omega$ |
| <b>Digital inputs (SDAEN, PGEB, B/GB)</b>  |                                    |                            |           |           |           |          |
| Logic low  | 4                                  | $V_{IL}$                   | 0         |           | 1.1       | V        |
| Logic high   |                                    | $V_{IH}$                   | 1.7       |           | +3.3      | V        |
| <b>Digital input DRRB</b>  |                                    |                            |           |           |           |          |
| Logic low  | 4                                  | $V_{IL}$                   | 0         |           | 0.8       | V        |
| Logic high   |                                    | $V_{IH}$                   | 1.5       |           | 3.3       | V        |
| <b>Analog controls (GA, SDA)</b>   |                                    |                            |           |           |           |          |
| Voltage range on GA <sup>(3)</sup>   | 4                                  | V(GA)                      | -0.5      | 0         | 0.5       | V        |
| Voltage range on SDA <sup>(4)</sup>  | 4                                  | V(SDA)                     | -0.5      | 0         | 0.5       | V        |
| <b>Digital Outputs</b>   |                                    |                            |           |           |           |          |
| Logic compatibility  | LVDS ( $V_{PLUSD} = 2.5V$ typical) |                            |           |           |           |          |
| Output levels 50 $\Omega$ transmission lines, 100 $\Omega$ (2 x 50 $\Omega$ ) differentially terminated                        |                                    |                            |           |           |           |          |
| - logic low  | 1                                  | $V_{OL}$                   |           | 1075      | 1250      | mV       |
| - logic high   | 1                                  | $V_{OH}$                   | 1250      | 1425      |           | mV       |
| - swing (each single-ended output)   | 1                                  | $V_{OH} - V_{OL}$          | 250       | 400       | 450       | mV       |
| - common mode  | 4                                  |                            |           |           |           | mV       |
| ..... max $V_{PLUSD} = 2.6V$   |                                    |                            |           |           |           |          |
| ..... typ $V_{PLUSD} = 2.5V$   | 1                                  |                            |           | 1250      |           | mV       |
| ..... min $V_{PLUSD} = 2.4V$   | 4                                  |                            |           |           |           | mV       |

**Table 3-3.** Electrical Operating Characteristics (Continued)

| Parameter                                | Test Level | Symbol | Min | Typ  | Max | Unit   |
|--|------------|--------|-----|------|-----|--------|
| <b>DC Accuracy</b>                       |            |        |     |      |     |        |
| DNLrms                                   | 1          | DNLrms |     | 0.2  | 0.3 | LSB    |
| Differential nonlinearity <sup>(1)</sup> | 1          | DNL+   |     | 0.8  | 1.5 | LSB    |
| Differential nonlinearity <sup>(1)</sup> | 1          | DNL-   |     |      |     |        |
| Integral nonlinearity <sup>(1)</sup>     | 1          | INL-   | -4  | -2.5 |     | LSB    |
| Integral nonlinearity <sup>(1)</sup>     | 1          | INL+   |     | 2.5  | 4   | LSB    |
| Gain central value <sup>(2)</sup>        | 1          |        | 0.9 | 1    | 1.1 |        |
| Gain error drift                         | 4          |        |     | 500  |     | ppm/°C |
| Input offset voltage                     | 1          |        | -10 |      | 10  | mV     |

- Notes: 1. Histogram testing at  $F_s = 390$  Msps  $F_{in} = 100$  MHz.  
2. The ADC Gain can be fine tuned to 1 thanks to the gain adjust function.  
3. Refer to [Section 8.7.6](#) for gain adjust transfer function.  
4. Refer to [Section 8.7.7](#) for SDA transfer function.

**Table 3-4.** AC Electrical Characteristics

| Parameter   | Test Level | Symbol | Min | Typ   | Max   | Unit |
|---|------------|--------|-----|-------|-------|------|
| <b>AC Analog Inputs</b>   |            |        |     |       |       |      |
| Full power input bandwidth <sup>(1)</sup>   | 4          | FPBW   |     | 3.8   |       | GHz  |
| Gain flatness <sup>(2)</sup>  | 4          | BF     |     | ±0.25 | ± 0.3 | dB   |
| Input voltage standing wave ratio <sup>(3)</sup><br>(DC to 2.5 GHz)   | 4          | VSWR   |     | 1.1:1 | 1.2:1 |      |
| AC performance: nominal condition, ambient temperature ( $T_J = 50^\circ\text{C}$ )<br>-1 dBFS Single ended input mode (unless otherwise specified), 50% clock duty cycle $P_{CLK}, CLKB = +4$ dBm (100Ω differentially driven), binary output data format. |            |        |     |       |       |      |
| <b>Signal-to-noise and Distortion Ratio</b>   |            |        |     |       |       |      |
| $F_s = 1.4$ Gsps $F_{in} = 700$ MHz   | 1          | SINAD  |     | 50    |       | dBFS |
| $F_s = 1.7$ Gsps $F_{in} = 1.7$ GHz   | 4          |        |     | 48    |       |      |
| $F_s = 2.2$ Gsps $F_{in} = 1.1$ GHz   | 4          |        |     | 48    |       |      |
| $F_s = 2.2$ Gsps $F_{in} = 2.0$ GHz   | 4          |        |     | 47    |       |      |
| <b>Effective Number of Bits</b>   |            |        |     |       |       |      |
| $F_s = 1.4$ Gsps $F_{in} = 700$ MHz   | 1          | ENOB   |     | 8.0   |       | Bit  |
| $F_s = 1.7$ Gsps $F_{in} = 1.7$ GHz   | 4          |        |     | 7.7   |       |      |
| $F_s = 2.2$ Gsps $F_{in} = 1.1$ GHz   | 4          |        |     | 7.6   |       |      |
| $F_s = 2.2$ Gsps $F_{in} = 2.0$ GHz   | 4          |        |     | 7.4   |       |      |
| <b>Signal to Noise Ratio</b>  |            |        |     |       |       |      |
| $F_s = 1.4$ Gsps $F_{in} = 700$ MHz   | 1          | SNR    |     | 53    |       | dBFS |
| $F_s = 1.7$ Gsps $F_{in} = 1.7$ GHz   | 4          |        |     | 51    |       |      |
| $F_s = 2.2$ Gsps $F_{in} = 1.1$ GHz   | 4          |        |     | 51    |       |      |
| $F_s = 2.2$ Gsps $F_{in} = 2.0$ GHz   | 4          |        |     | 49    |       |      |

Table 3-4. AC Electrical Characteristics (Continued)

| Parameter  | Test Level | Symbol | Min | Typ | Max | Unit |
|--|------------|--------|-----|-----|-----|------|
| <b>Total Harmonic Distortion (nine harmonics)</b>      |            |        |     |     |     |      |
| Fs = 1.4 Gsps      Fin = 700 MHz                       | 1          | ITHDI  |     | 58  |     | dBFS |
| Fs = 1.7 Gsps      Fin = 1.7 GHz                       | 4          |        | 55  |     |     |      |
| Fs = 2.2 Gsps      Fin = 1.1 GHz                       | 4          |        | 55  |     |     |      |
| Fs = 2.2 Gsps      Fin = 2.0 GHz                       | 4          |        | 52  |     |     |      |
| <b>Spurious Free Dynamic Range</b>                     |            |        |     |     |     |      |
| Fs = 1.4 Gsps      Fin = 700 MHz                       | 1          | ISFDRI |     | 62  |     | dBFS |
| Fs = 1.7 Gsps      Fin = 1.7 GHz                       | 4          |        | 58  |     |     |      |
| Fs = 2.2 Gsps      Fin = 1.1 GHz                       | 4          |        | 58  |     |     |      |
| Fs = 2.2 Gsps      Fin = 2.0 GHz                       | 4          |        | 54  |     |     |      |
| <b>Two-tone Third Order Intermodulation Distortion</b> |            |        |     |     |     |      |
| Fs = 1.7 Gsps (–7 dBFS each tone)                      |            | IIMD3I |     |     |     | dBFS |
| Fin1 = 995 MHz      Fin2 = 1005 MHz                    | 4          |        | 60  |     |     |      |
| Fin1 = 1545 MHz      Fin2 = 1555 MHz                   | 4          |        | 59  |     |     |      |
| Fin1 = 1945 MHz      Fin2 = 1955 MHz                   | 4          |        | 59  |     |     |      |

- Notes: 1. See “Definition of Terms” on page 31.  
2. From DC to 1.5 GHz  
3. Specified from DC up to 2.5 GHz input signal. Input VSWR is measured on a soldered device. It assumes an external 50Ω ± 2Ω controlled impedance line, and a 50Ω driving source impedance ( $S_{11} < -30$  dB from DC to 3 GHz).

Table 3-5. Transient and Switching Performances

| Parameter  | Test Level | Symbol | Min  | Typ | Max               | Unit             |
|--|------------|--------|------|-----|-------------------|------------------|
| <b>Transient Performance</b>                               |            |        |      |     |                   |                  |
| Bit error rate <sup>(1)</sup>                              | 4          | BER    |      |     | 10 <sup>-15</sup> | Error/<br>Sample |
| ADC settling time (VIN-VINB = 400 mVpp)                    | 4          | TS     |      | 400 |                   | ps               |
| Overvoltage recovery time                                  | 4          | ORT    |      |     | 500               | ps               |
| ADC step response rise/fall time (10% to 90%)              | 4          |        |      | 80  | 100               | ps               |
| Overshoot  | 5          |        |      | 4   |                   | %                |
| Ringback   | 5          |        |      | 2   |                   | %                |
| <b>Switching Performance and Characteristics</b>           |            |        |      |     |                   |                  |
| Maximum clock frequency <sup>(2)</sup>                     |            | Fs Max | 2.2  |     |                   | Gsps             |
| Minimum clock frequency <sup>(2)</sup>                     | 4          | Fs Min |      |     | 200               | Mpsps            |
| Minimum clock pulse width (high)                           | 4          | TC1    | 0.22 |     | 2.5               | ns               |
| Minimum clock pulse width (low)                            | 4          | TC2    | 0.22 |     | 2.5               | ns               |
| Aperture delay <sup>(2)</sup>                              | 4          | TA     |      | 160 |                   | ps               |
| Aperture uncertainty <sup>(2)</sup>                        | 4          | Jitter |      | 150 | 200               | fs rms           |
| Output rise/fall time for data (20% to 80%) <sup>(3)</sup> | 4          | TR/TF  |      | 80  | 110               | ps               |

**Table 3-5.** Transient and Switching Performances (Continued)

| Parameter  | Test Level | Symbol    | Min | Typ | Max  | Unit         |
|--|------------|-----------|-----|-----|------|--------------|
| Output rise/fall time for data ready (20% to 80%) <sup>(3)</sup> | 4          | TR/TF     |     | 80  | 110  | ps           |
| Data output delay <sup>(4)</sup>                                 | 4          | TOD       |     | 360 |      | ps           |
| Data ready output delay <sup>(4)</sup>                           | 4          | TDR       |     | 360 |      | ps           |
|  | 4          | ITOD–TDRI | –50 | 0   | + 50 | ps           |
| Output Data to Data Ready propagation delay <sup>(5)</sup>       | 4          | TD1       | 200 | 250 | 250  | ps           |
| Data ready to output data propagation delay <sup>(5)</sup>       | 4          | TD2       | 150 | 200 | 250  | ps           |
| Output data pipeline delay                                       | 4          | TPD       | 4.0 |     |      | Clock Cycles |
| Data ready reset delay   | 4          | TRDR      | 300 |     |      | ps           |

- Notes:
1. Output error amplitude  $< \pm 32$  lsb.  $F_s = 2.2$  Gsps  $T_J = 110^\circ\text{C}$
  2. See “Definition of Terms” on page 31.
  3.  $50\Omega // C_{LOAD} = 2$  pF termination (for each single-ended output). Termination rise/ fall time load parasitic capacitance derating value: 50 ps/pF. See “Timing Information” on page 33.
  4. TOD and TDR propagation times are defined at package input/outputs. They are given for reference only
  5. Values for TD1 and TD2 are given for a 2.2 Gsps external clock frequency (50% duty cycle). For different sampling rates, apply the following formula:  $TD1 = T/2 + (ITOD - TDRI)$  and  $TD2 = T/2 + (ITOD - TDRI)$ , where  $T =$  clock period. This places the rising edge (True-False) of the differential data ready signal in the middle of the output data valid window. This gives maximum setup and hold times for external data acquisition.

### 3.4 Explanation of Test Levels

**Table 3-6.** Explanation of Test Levels

|   |  |
|---|--|
| 1 | 100% production tested at $+25^\circ\text{C}^{(1)}$ (for $C$ temperature range <sup>(2)</sup> )  |
| 2 | 100% production tested at $+25^\circ\text{C}^{(1)}$ , and sample tested at specified temperatures (for $V$ temperature ranges <sup>(2)</sup> ) |
| 3 | Sample tested only at specified temperatures   |
| 4 | Parameter is guaranteed by design and characterization testing (thermal steady-state conditions at specified temperature)                      |
| 5 | Parameter is a typical value only guaranteed by design only  |

Only minimum and maximum values are guaranteed (typical values are issuing from characterization results).

- Notes:
1. Unless otherwise specified.
  2. Refer to “Ordering Information” on page 43.

### 3.5 Functions Description

**Table 3-7.** Functions Description

| Name               | Function  |
|--------------------|---|
| V <sub>CC</sub>    | Positive power supply: + 3.3V                       |
| V <sub>PLUSD</sub> | Positive power supply for LVDS buffers: + 2.5V      |
| V <sub>EE</sub>    | Negative power supply: -2.2V (substrate)            |
| VIN, VINB          | Differential analog input                           |
| CLK, CLKB          | Differential clock input                            |
| [D0:D9][D0B:D9B]   | Differential output data                            |
| OR, ORB            | Differential out-of-range                           |
| DR, DRB            | Differential data ready                             |
| DRRB               | Active low data ready reset                         |
| PGEB               | Active high pattern generator enable                |
| SDA                | Sampling delay adjust input                         |
| SDAEN              | Active high sampling delay adjust enable            |
| GA                 | Gain adjust input                                   |
| DIODE              | Diode input for die junction temperature monitoring |

### 3.6 Timing Diagram

Figure 3-1. Timing Diagram

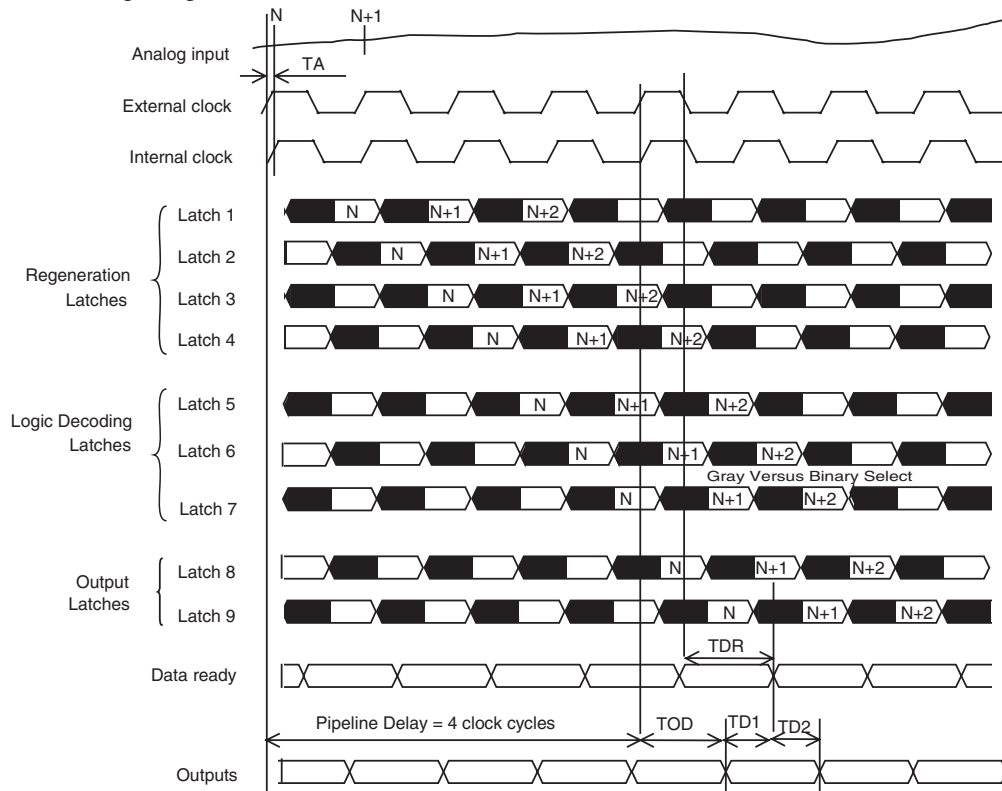

### 3.7 Coding

Table 3-8. ADC Coding Table

| Differential Analog Input | Voltage Level                      | Digital Output  |   |  |   |
|---------------------------|------------------------------------|---|---|--|---|
|                           |                                    | Binary (B/GB = GND or floating)<br>MSB.....LSB Out-of-Range |   | Gray (B/GB = V <sub>CC</sub> )<br>MSB.....LSB Out-of-Range |   |
| > +250.25 mV              | >Top end of full-scale + ½ LSB     | 1 1 1 1 1 1 1 1 1 1   | 1 | 1 0 0 0 0 0 0 0 0 0  | 1 |
| +250.25 mV                | Top end of full-scale + ½ LSB      | 1 1 1 1 1 1 1 1 1 1   | 0 | 1 0 0 0 0 0 0 0 0 0  | 0 |
| +249.75 mV                | Top end of full-scale – ½ LSB      | 1 1 1 1 1 1 1 1 1 0   | 0 | 1 0 0 0 0 0 0 0 0 1  | 0 |
| +125.25 mV                | 3/4 full-scale + ½ LSB             | 1 1 0 0 0 0 0 0 0 0   | 0 | 1 0 1 0 0 0 0 0 0 0  | 0 |
| +124.75 mV                | 3/4 full-scale – ½ LSB             | 1 0 1 1 1 1 1 1 1 1   | 0 | 1 1 1 0 0 0 0 0 0 0  | 0 |
| +0.25 mV                  | Midscale + ½ LSB                   | 1 0 0 0 0 0 0 0 0 0   | 0 | 1 1 0 0 0 0 0 0 0 0  | 0 |
| –0.25 mV                  | Midscale – ½ LSB                   | 0 1 1 1 1 1 1 1 1 1   | 0 | 0 1 0 0 0 0 0 0 0 0  | 0 |
| –124.75 mV                | 1/4 full–scale + ½ LSB             | 0 1 0 0 0 0 0 0 0 0   | 0 | 0 1 1 0 0 0 0 0 0 0  | 0 |
| –124.25 mV                | 1/4 full-scale – ½ LSB             | 0 0 1 1 1 1 1 1 1 1   | 0 | 0 0 1 0 0 0 0 0 0 0  | 0 |
| –249.75 mV                | Bottom end of full-scale + ½ LSB   | 0 0 0 0 0 0 0 0 0 1   | 0 | 0 0 0 0 0 0 0 0 0 1  | 0 |
| –250.25 mV                | Bottom end of full-scale – ½ LSB   | 0 0 0 0 0 0 0 0 0 0   | 0 | 0 0 0 0 0 0 0 0 0 0  | 0 |
| < –250.25 mV              | < Bottom end of full-scale – ½ LSB | 0 0 0 0 0 0 0 0 0 0   | 1 | 0 0 0 0 0 0 0 0 0 0  | 1 |

## 4. Pin Description

**Table 4-1.** Pin Description (CBGA 152 and CI-CGA152)

| Symbol   | Pin Number   | Function  |
|--|--|---|
| <b>Power Supplies</b>                            |  |   |
| V <sub>CC</sub>                                  | K1, K2, J3, K3, B6, C6, A7, B7, C7, P8, Q8, R8   | +3.3V analog supply (connected to same power supply plane)  |
| GND  | B1, C1, D1, G1, M1, Q1, B2, C2, D2, E2, F2, G2, N2, P2, Q2, A3, B3, D3, E3, F3, G3, N3, P4, Q4, R4, A5, P5, Q5, P6, Q6, P7, Q7, R7, B9, B10, B11, R11, P12, A14, B14, C14, G14, K14, P14, Q14, R14, B15, Q15, B16, Q16 | Analog ground   |
| D <sub>GND</sub>                                 | A13, B13, C13, P13, Q13, R13, H14, J14   | Output buffers digital ground   |
| V <sub>EE</sub>                                  | H1, J1, L1, H2, J2, L2, M2, C3, H3, L3, M3, P3, Q3, R3, A4, B4, C4, B5, C5, A8, B8, C8, C9, P9, Q9, C10, Q10, R10  | −2.2V analog supply (connected to same power supply plane)  |
| V <sub>PLUSD</sub>                               | P10, C11, P11, Q11, A12, B12, C12, Q12, R12, D14, E14, F14, L14, M14, N14  | +2.5V digital positive supply   |
| <b>Analog Inputs</b>                             |  |   |
| VIN  | R5   | In-phase (+) analog input signal of the differential sample and hold preamplifier   |
| VINB   | R6   | Inverted phase (−) analog input signal of the differential sample and hold preamplifier   |
| <b>Clock Inputs</b>                              |  |   |
| CLK  | E1   | In-phase (+) clock input  |
| CLKB   | F1   | Inverted phase (−) clock input  |
| <b>Digital Outputs</b>                           |  |   |
| D0, D1, D2, D3, D4, D5, D6, D7, D8, D9           | D16, E16, F16, G16, J16, K16, L16, M16, N16, P16   | In-phase (+) digital outputs D0 is the LSB, D7 is the MSB   |
| D0B, D1B, D2B, D3B, D4B, D5B, D6B, D7B, D8B, D9B | D15, E15, F15, G15, J15, K15, L15, M15, N15, P15   | Inverted phase (−) digital outputs  |
| OR   | C16  | In-phase (+) out-of-range output  |
| ORB  | C15  | Inverted phase (−) out-of-range output  |
| DR   | H16  | In-phase (+) data ready signal output   |
| DRB  | H15  | Inverted phase (−) data ready signal output   |
| <b>Additional Functions</b>                      |  |   |
| B/GB   | A11  | Binary or Gray select output format control<br>- binary output format if B/GB is floating or connected to GND<br>- Gray output format if B/GB is connected to V <sub>CC</sub> |
| DIODE  | A10  | To be left floating or tied to GND. Input to be used for junction temperature monitoring when 1 mA current is applied   |

**Table 4-1.** Pin Description (CBGA 152 and CI-CGA152) (Continued)

| Symbol | Pin Number | Function  |
|--------|------------|---|
| PGEB   | A9         | Active high pattern generator enable<br>- digitized input delivered at outputs according to B/GB if PGEB is floating or connected to GND<br>- checker Board pattern delivered at outputs if PGEB is connected to $V_{CC}$ |
| DRRB   | N1         | Asynchronous data ready reset function<br>- active low = GND<br>- inactive high = $V_{CC}$  |
| GA     | R9         | Gain adjust   |
| SDA    | A6         | Sampling delay adjust<br>Active if SDAEN active   |
| SDAEN  | P1         | Sampling delay adjust enable inactive if floating or connected to GND active if connected to $V_{CC}$   |

Figure 4-1. CBGA152 and CI-CGA152 Pinout

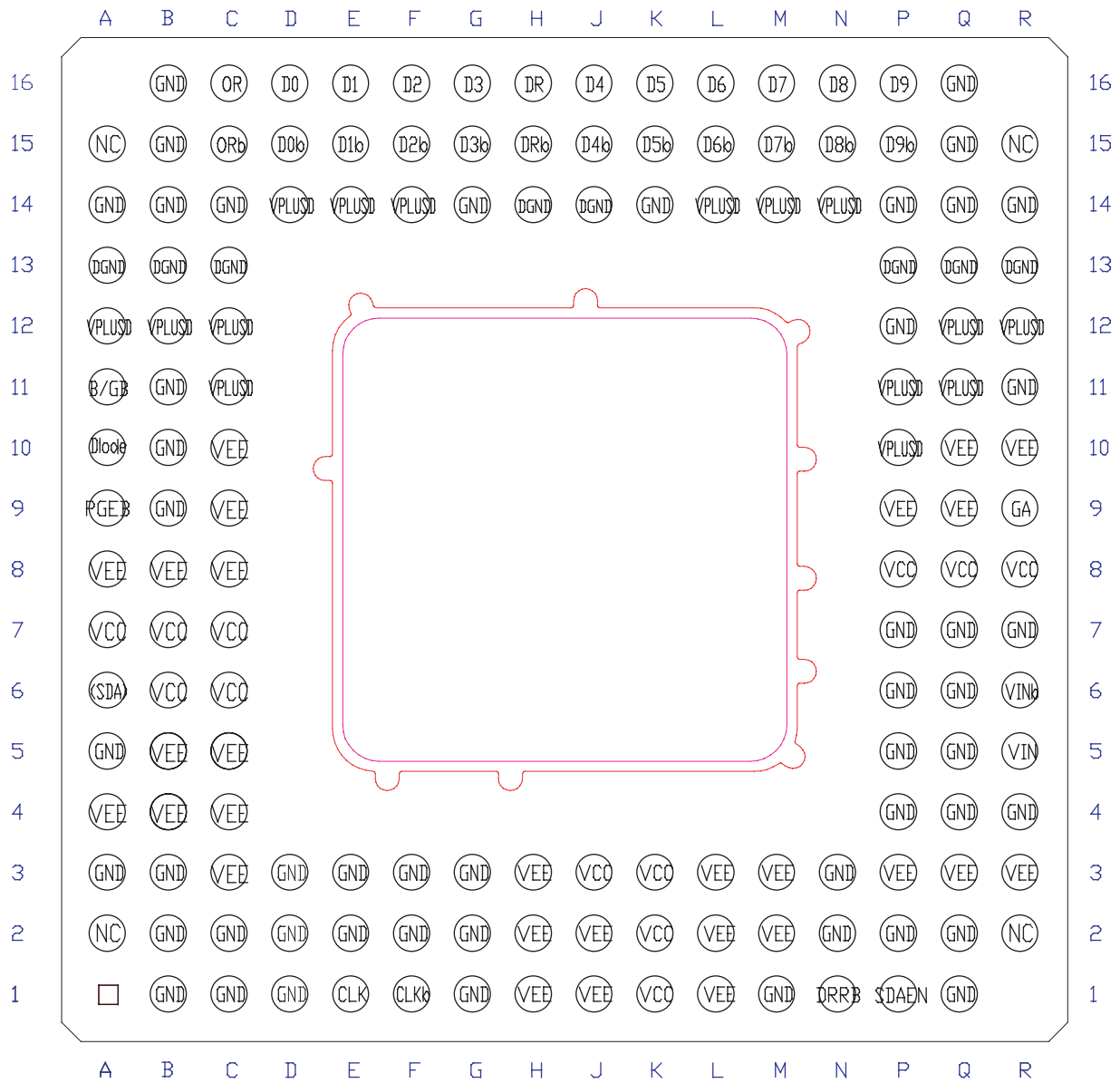

- Notes:
1. If required, 4 NC balls can be electrically connected to GND if simplifying PCB routing.
  2. The pinout is given with a bottom view. The way the columns and rows were defined is different from the JEDEC standard.

## 4.1 Package Description

### 4.1.1 Hermetic CBGA 152 Outline Dimensions

Ceramic body size: 21 × 21 mm

Ball pitch: 1.27 mm

Cofired: Al<sub>2</sub>O<sub>3</sub>

Optional: discrete capacitor mounting lands on top side of package for extra decoupling.

Figure 4-2. Mechanical Description Bottom View

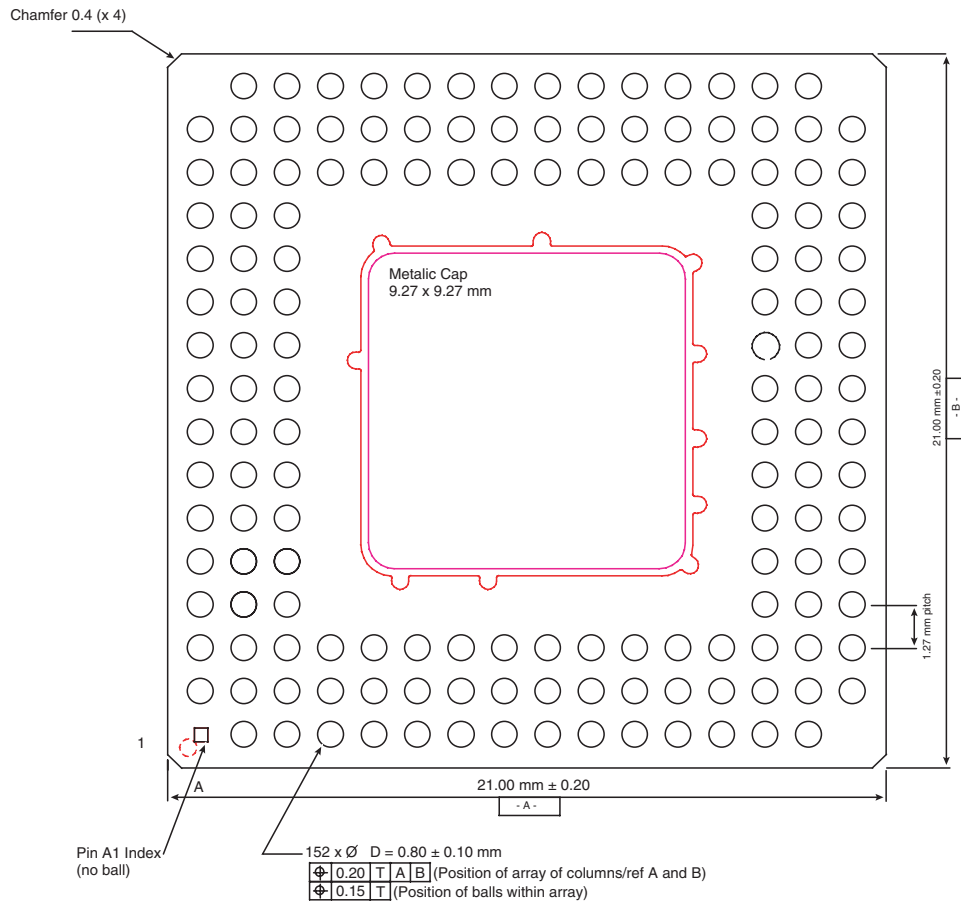

4.1.2 Cross Section  
Cross Section

CBGA 152 21x21 mm Cross Section  
10 bits/2.2 Gbps ADC. External heatsink required

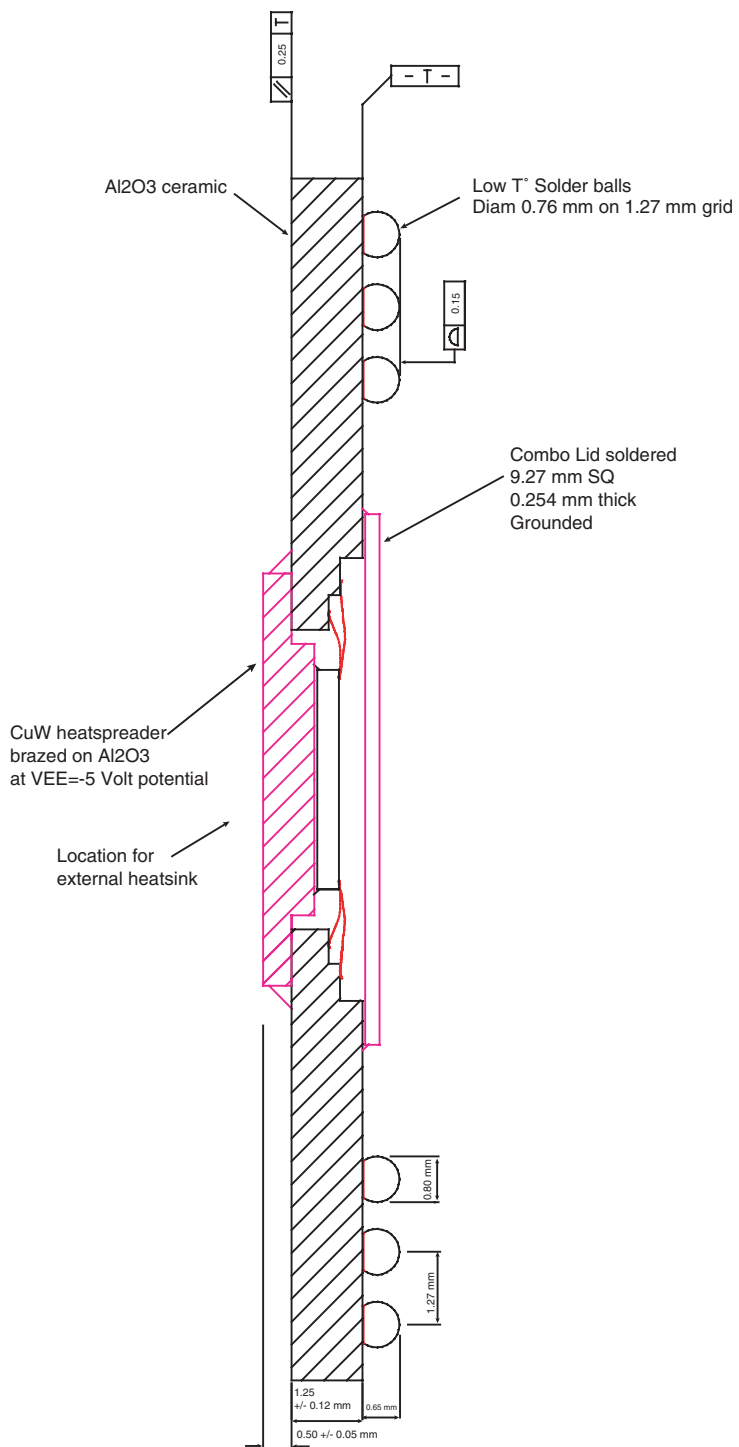

4.1.3 Mechanical Up View

Figure 4-3. Isometric View

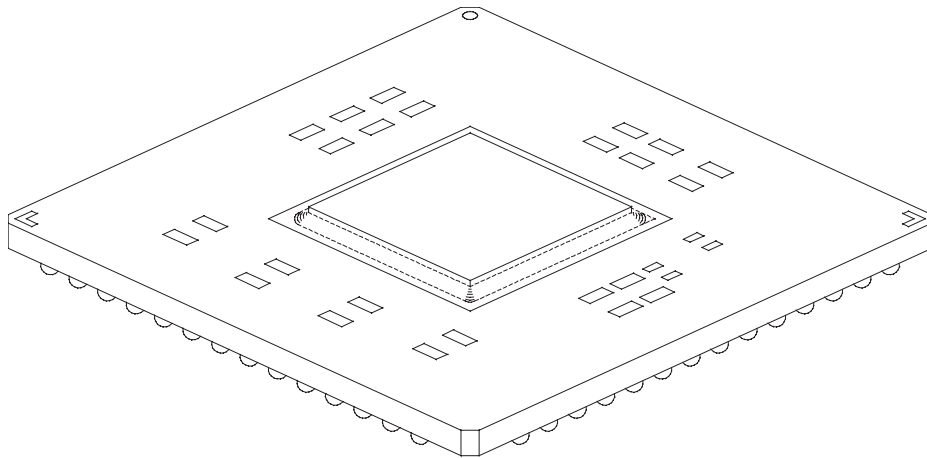
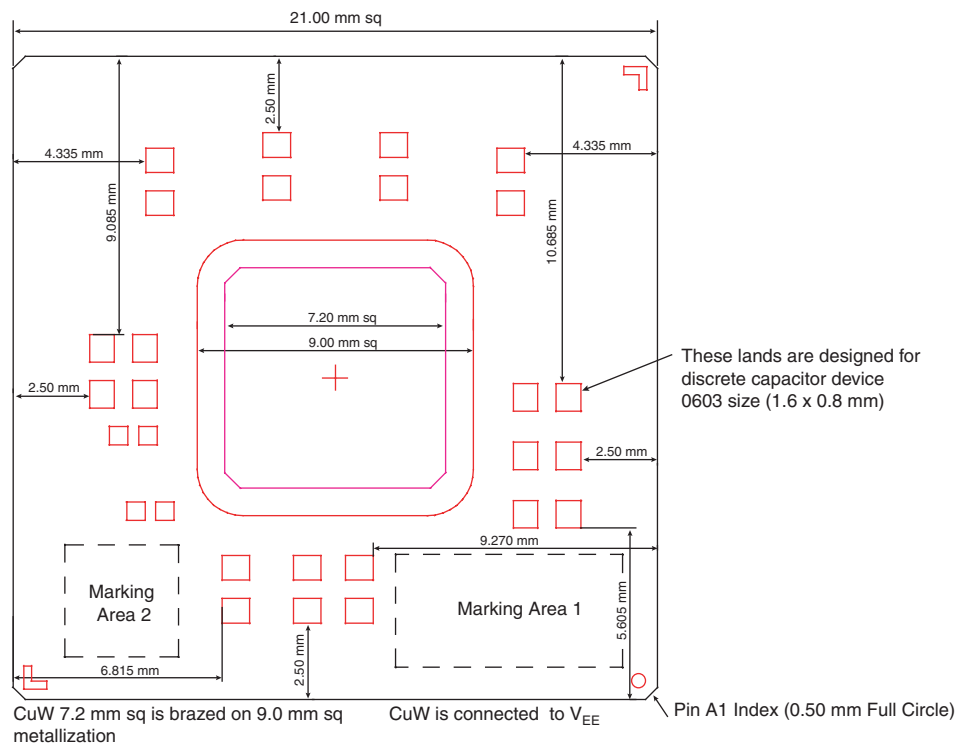

Figure 4-4. Package Top View





4.1.4 CI-CGA Mechanical Description

Figure 4-6. CI-CGA 152 Mechanical Description (Bottom View)

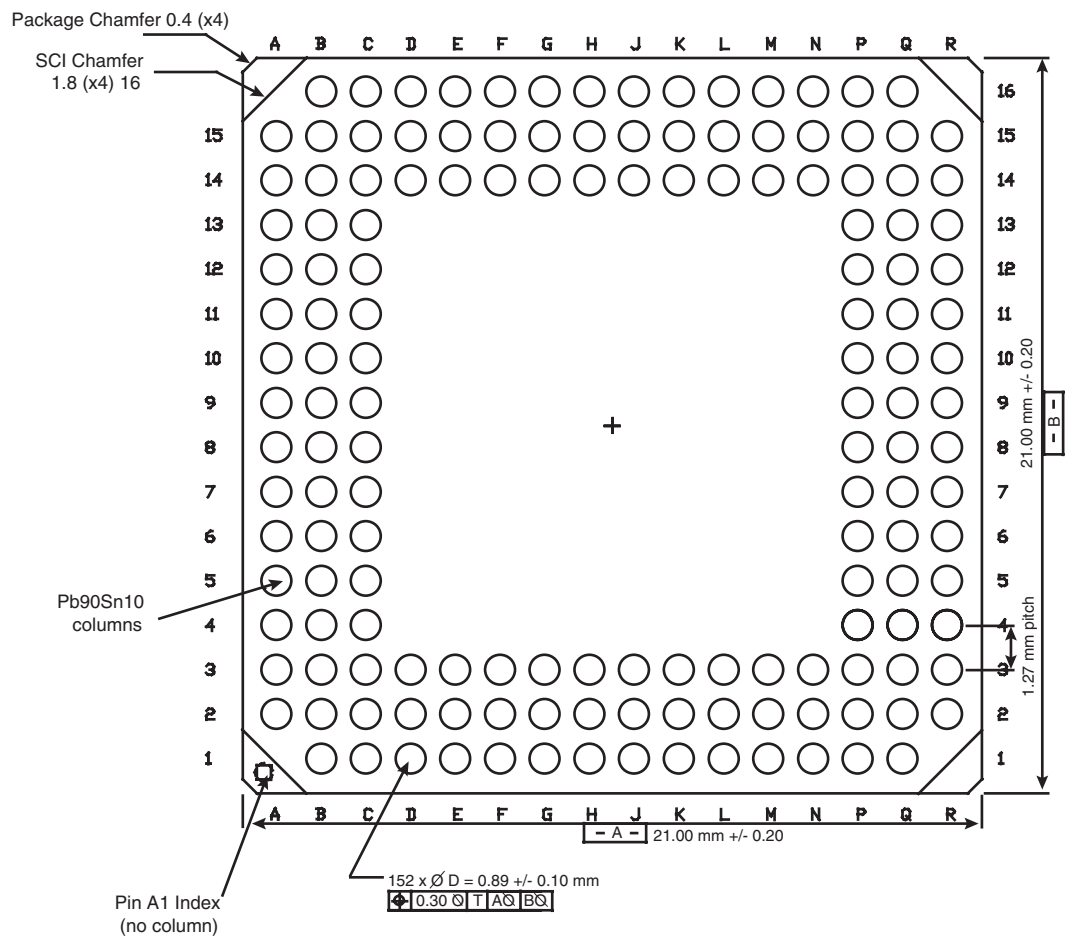

Figure 4-7. Hermetic CI-CGA 152 Cross Section

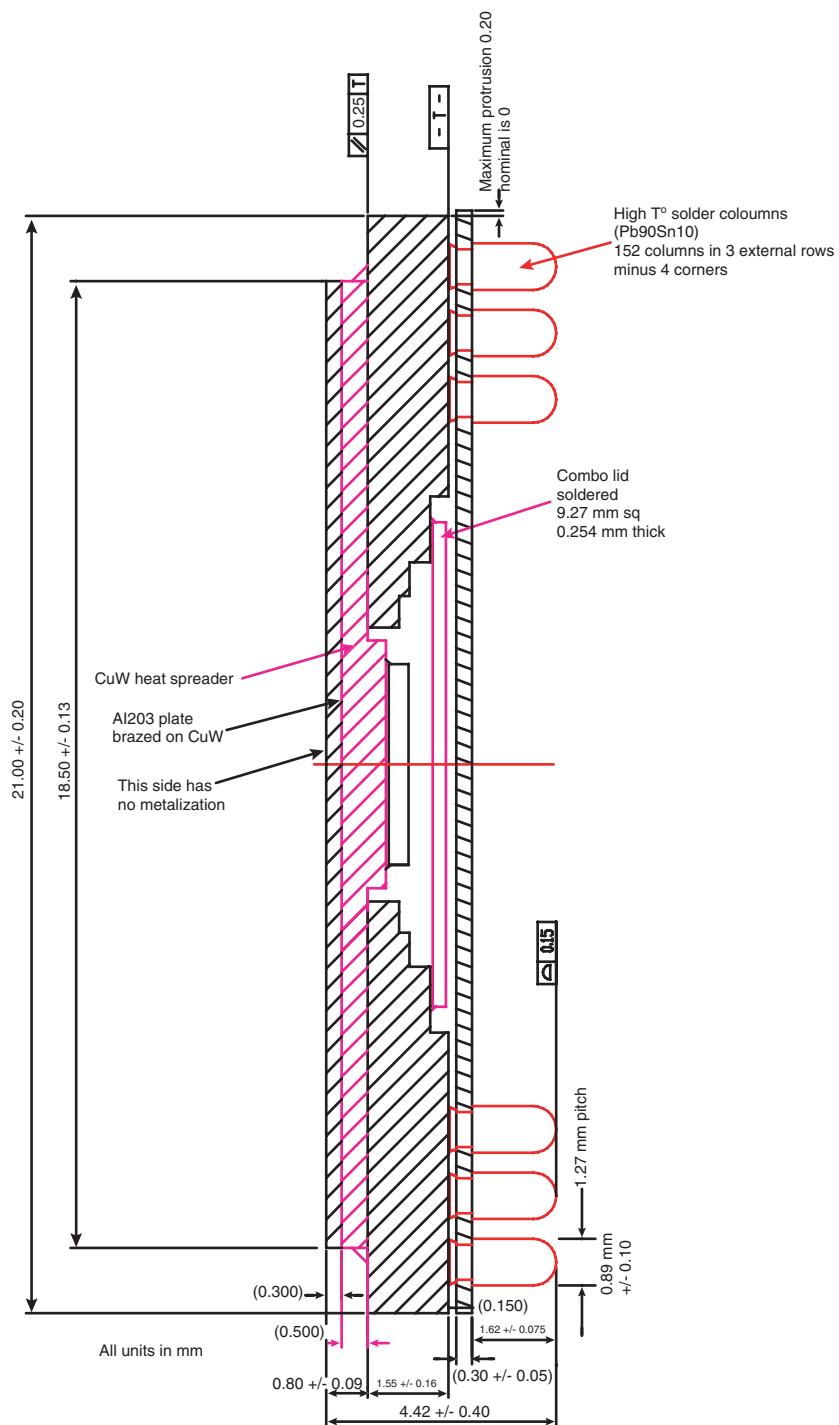
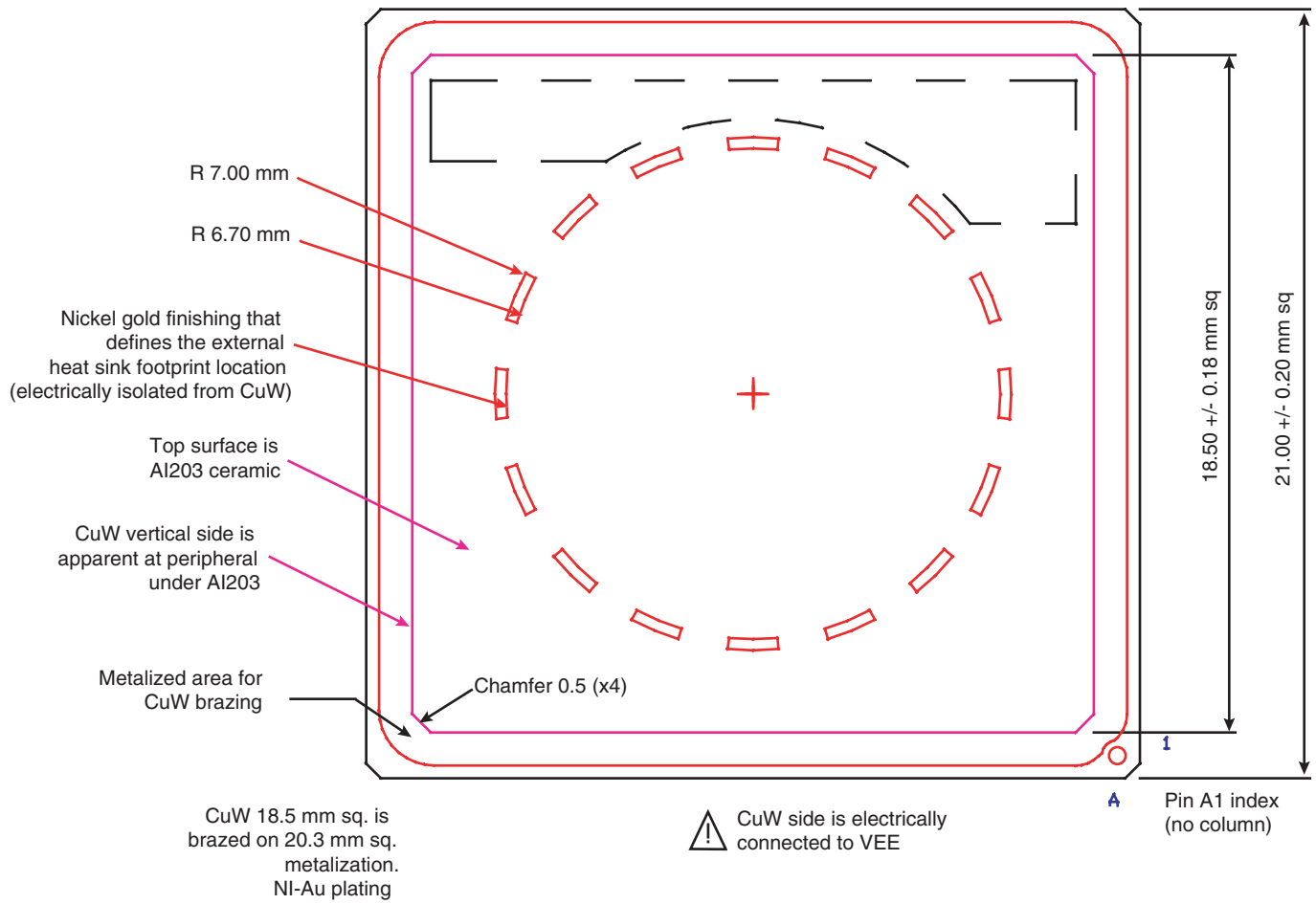

Figure 4-8. CI-CGA 152 Package Top View



## 5. Thermal and Moisture Characteristics

### 5.1 Dissipation by Conduction and Convection (CBGA 152)

The thermal resistance from junction to ambient  $R_{TH_{JA}}$  is around  $30^{\circ}\text{C}/\text{W}$ . Therefore, to lower  $R_{TH_{JA}}$  it is mandatory to use an external heatsink to improve dissipation by convection and conduction. The heat-sink should be fixed in contact with the top side of the package (CuW heatspreader over  $\text{Al}_2\text{O}_3$ ) which is at  $-5\text{V}$ . The heatsink needs to be electrically isolated; using an adequate low  $R_{th}$  electrical isolation.

Example:

The thermal resistance from case to ambient  $R_{TH_{CA}}$  is typically  $4.0^{\circ}\text{C}/\text{W}$  (0 m/s air flow or still air) with the heatsink depicted in figure 1, of dimensions  $50\text{mm} \times 50\text{mm} \times 22\text{mm}$  (respectively  $L \times l \times H$ ). Global junction to ambient thermal resistance  $R_{TH_{JA}}$  is:

$4.35^{\circ}\text{C}/\text{W}$   $R_{TH_{JC}}$  +  $2.0^{\circ}\text{C}/\text{W}$  thermal grease resistance +  $4.0^{\circ}\text{C}/\text{W}$   $R_{TH_{CA}}$  (case to ambient) + =  $0.35^{\circ}\text{C}/\text{W}$  total ( $R_{TH_{JA}}$ ).

Assuming:

- Typical thermal resistance from junction to bottom of case  $R_{TH_{JC}}$  is  $4.35^{\circ}\text{C}/\text{Watt}$  (Finite Element Method thermal simulation results). This value does not include thermal contact resistance between package and external heatsink (glue, paste, or thermal foil interface for example). As an example, use  $2.0^{\circ}\text{C}/\text{W}$  value for  $50\ \mu\text{m}$  thickness of thermal grease.

Note: Example of calculation of ambient temperature  $T_A$  max to ensure  $T_J$  max =  $110^{\circ}\text{C}$ : assuming  $R_{TH_{JA}} = 10.35^{\circ}\text{C}/\text{W}$  and Power dissipation =  $4.0\text{W}$ ,  $T_A$  max =  $T_J - (R_{TH_{JA}} \times 4.0\text{W}) = 110 - (10.35 \times 4.0) = 68.6^{\circ}\text{C}$   
 $T_A$  max can be increased lowering  $R_{TH_{JA}}$  with adequate air flow (2 m/s, for example).

**Figure 5-1.** Black Anodized Aluminum Heatsink Glued on a Copper Base Screwed on Board (All Dimensions in mm).

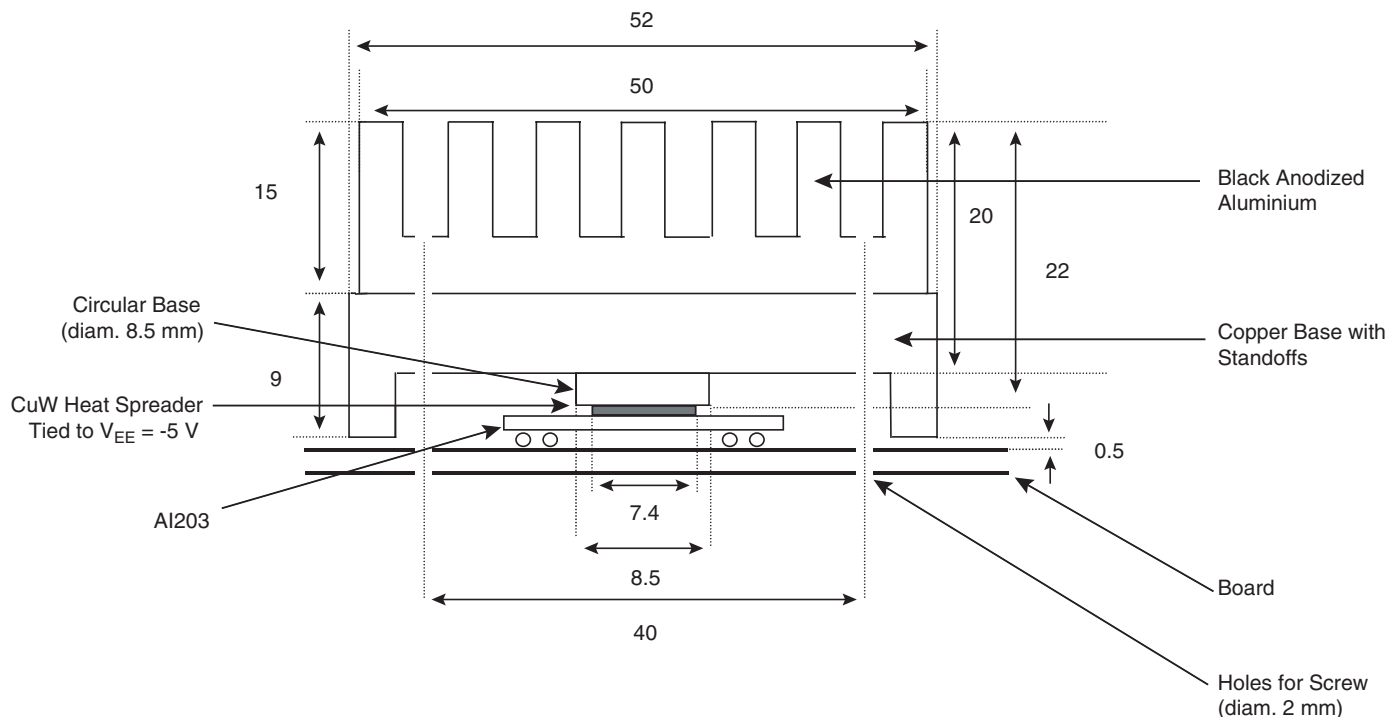

Cooling system efficiency can be monitored using the temperature sensing diodes, integrated in the device.

## 5.2 Thermal Dissipation by Conduction Only (CBGA 152)

When external heatsink cannot be used the relevant thermal resistance is thermal resistance from junction to bottom of balls:

$R_{TH_{J-Bottom-of-balls}}$  Thermal path, in this case, is junction, then silicon, glue, CuW heatspreader, Al<sub>2</sub>O<sub>3</sub> of package, and balls (Sn63Pb37). Finite Element Method (FEM) with thermal simulator lead to  $R_{TH_{J-bottom\ of\ balls}} = 12.3^{\circ}C/Watt$ . This value assume pure conduction from junction to bottom of balls.(that is worst case, no radiation and no convection applied). With such assumption the  $R_{TH_{J- Bottom-of-balls}}$  is user independent. To complete thermal analysis, user must add the thermal resistance from top of board (on which is soldered the device) to ambient, which value is user dependent (type of board, thermal via, area covered by copper in each layer of the board, thickness, airflow or cold plate are parameters to consider).

## 5.3 Dissipation by Conduction and Convection (CI-CGA 152)

The thermal resistance from junction to ambient  $R_{TH_{JA}}$  is around  $30^{\circ}C/W$ . Therefore, to lower  $R_{TH_{JA}}$ , it is mandatory to use an external heat sink to improve dissipation by convection and conduction. The heat sink should be fixed in contact with the top side of the package (Al<sub>2</sub>O<sub>3</sub> isolation over CuW heat spreader).

The heat sink does not need to be electrically isolated, because the top of the package is already electrically isolated thanks to a 0.30 mm Al<sub>2</sub>O<sub>3</sub> layer.

Example:

The thermal resistance from case to ambient  $R_{TH_{CA}}$  is typically  $4.0^{\circ}C/W$  (0 m/s air flow or still air) with the heat sink depicted in [Figure 5-2 on page 26](#), of dimensions 50 mm x 50 mm x 28 mm (respectively L x l x H).

The global junction to ambient thermal resistance  $R_{TH_{JA}}$  is:  
 $4.8^{\circ}C/W R_{TH_{JC}} + 2.0^{\circ}C/W$  thermal grease resistance +  $4.0^{\circ}C/W R_{TH_{CA}}$  (case to ambient) =  $10.8^{\circ}C/W$  total ( $R_{TH_{JA}}$ ).

Assuming:

A typical thermal resistance from the junction to the top of the case  $R_{TH_{JC}}$  of  $4.35^{\circ}C/W$  (finite element method thermal simulation results): this value does not include the thermal contact resistance between the package and the external heat sink (glue, paste, or thermal foil interface, for example). As an example, use a  $2.0^{\circ}C/W$  value for a 50  $\mu$ m thickness of thermal grease.

Note: Example of the calculation of the ambient temperature  $T_A$  max to ensure  $T_J$  max =  $110^{\circ}C$ :  
 assuming  $R_{TH_{JA}} = 10.8^{\circ}C/W$  and power dissipation = 4.0W,  $T_A$  max =  $T_J - (R_{TH_{JA}} \times 4.0W) = 110 - (10.8 \times 4.0) = 66.8^{\circ}C$ .  $T_A$  max can be increased by lowering  $R_{TH_{JA}}$  with an adequate air flow (2 m/s, for example).

**Figure 5-2.** Black Anodized Aluminium Heat Sink Glued on a Copper Base Screwed on Board (all dimensions in mm)

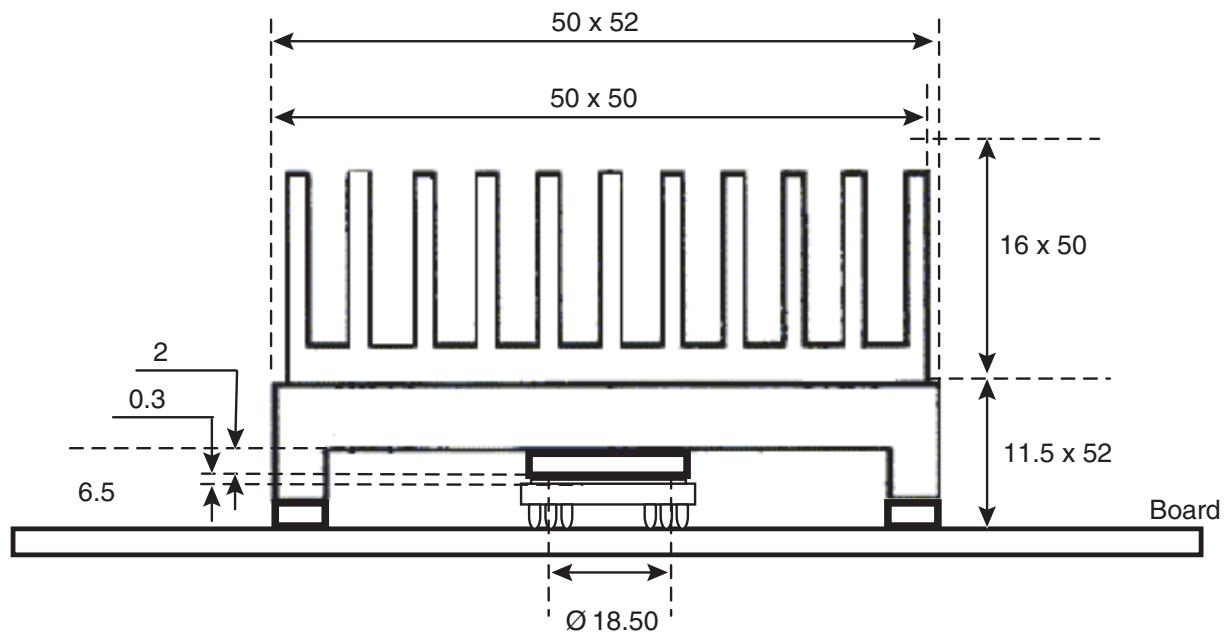

Note: The cooling system efficiency can be monitored using the temperature sensing diodes, integrated in the device

### 5.3.1 Thermal Dissipation by Conduction Only (CI-CGA 152)

When the external heat sink cannot be used, the relevant thermal resistance is the thermal resistance from the junction to the bottom of the columns:  $RTH_{J\text{-Bottom-of-columns}}$

The thermal path, in this case, is the junction, then the silicon, glue, CuW heat spreader, package Al<sub>2</sub>O<sub>3</sub>, and the columns (Sn10Pb90).

The Finite Element Method (FEM) with the thermal simulator leads to  $RTH_{J\text{-bottom-of-columns}} = 7.4^{\circ}\text{C/W}$ . This value assumes pure conduction from the junction to the bottom of the columns (this is the worst case, no radiation and no convection is applied). With such an assumption,  $RTH_{J\text{-Bottom-of-columns}}$  is user-independent.

To complete the thermal analysis, you must add the thermal resistance from the top of the board (on which the device is soldered) to the ambient resistance, whose values are user-dependent (the type of board, thermal, routing, area covered by copper in each board layer, thickness, airflow or cold plate are all parameters to consider).

In the case of the CI-CGA 152 package, the thermal resistance from the junction to the top of the package (via the CuW heat spreader covered by Al<sub>2</sub>O<sub>3</sub>) is  $RTH_{J\text{-top-of-package}} = 4.8^{\circ}\text{C/W}$ .

Figure 5-3. Thermal Net

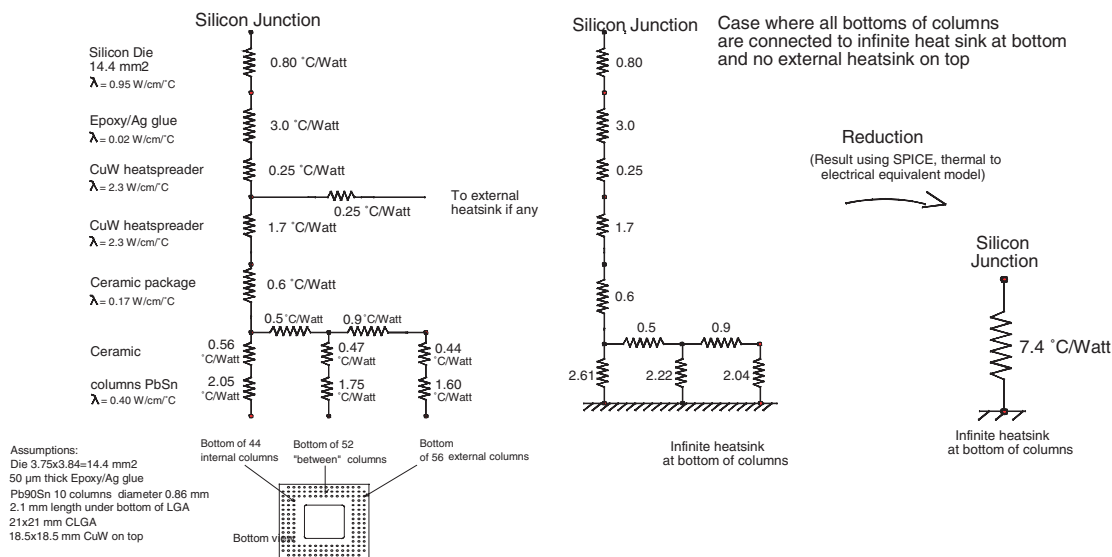

## 6. Equivalent Input/Output Schematics

Figure 6-1. Analog Input Equivalent Schematics and ESD Protection

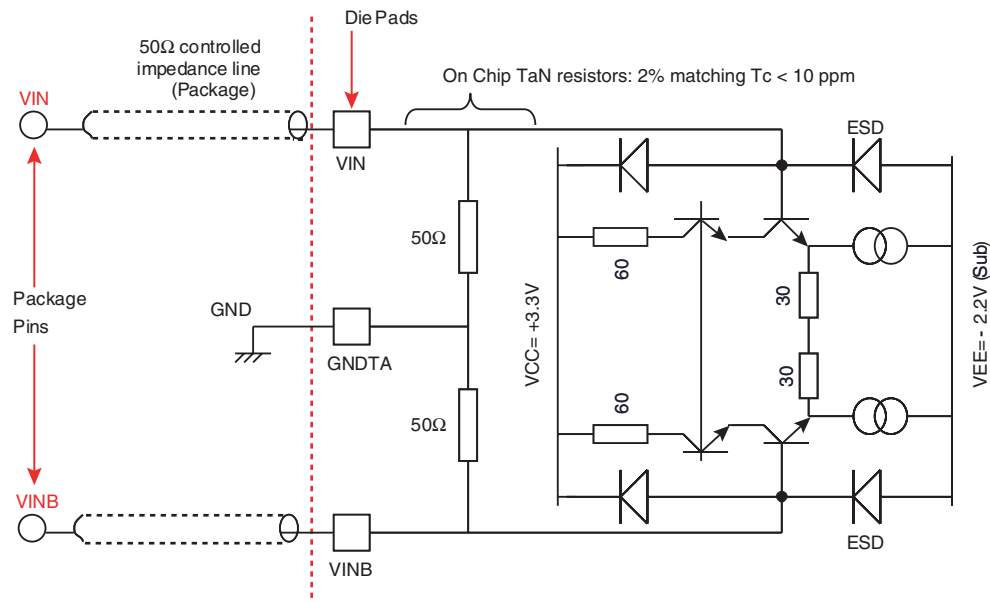

Note: 100Ω termination mid point is on-chip and DC coupled to ground.

Figure 6-2. Clock Input Equivalent Schematics and ESD Protection

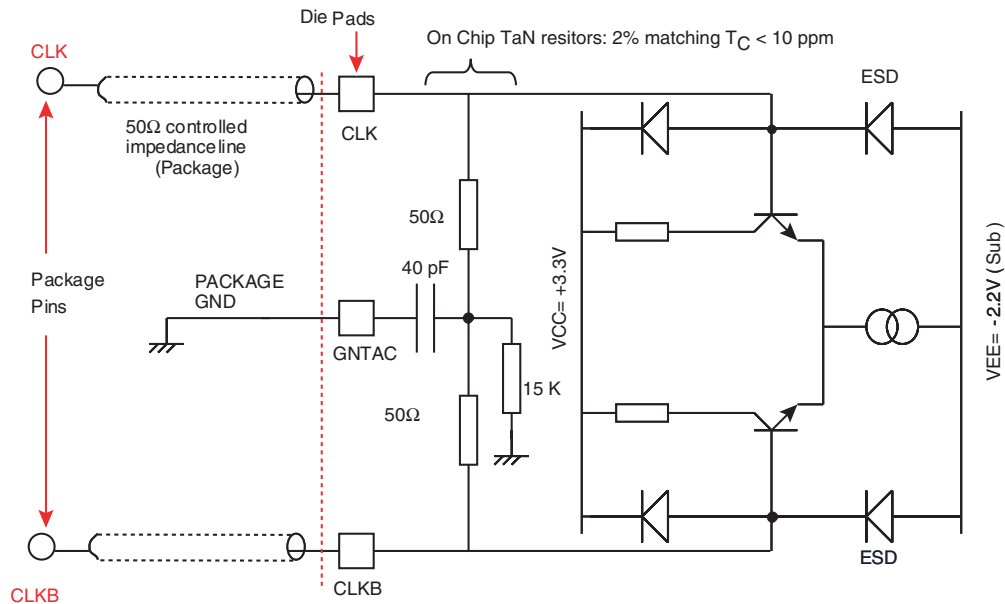

Note: 100Ω termination mid point is on chip and AC coupled to ground through a 40 pF capacitor.

Figure 6-3. Digital LVDS Output Buffers Equivalent Schematic and ESD Protection

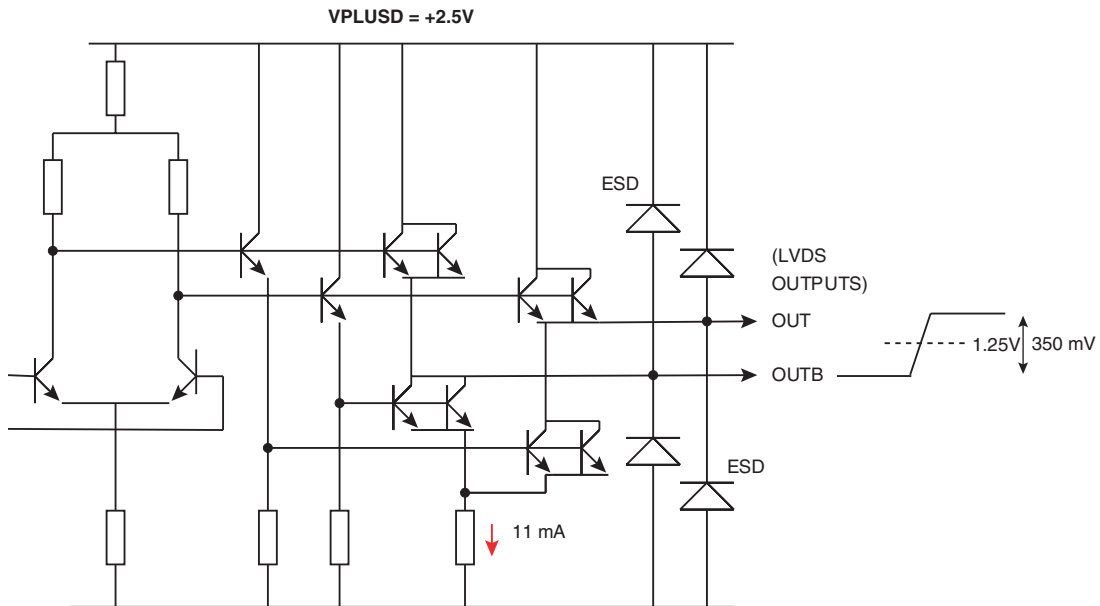

**Figure 6-4.** GA and SDA: Gain Adjust and Sampling Delay Adjust, Equivalent Input Schematics

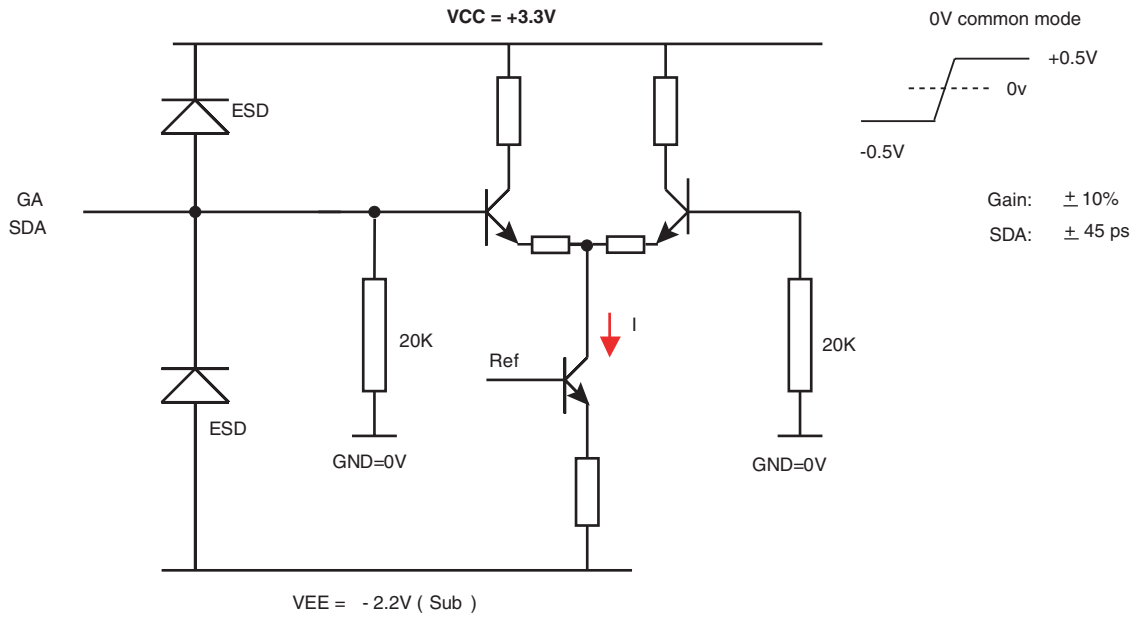

**Figure 6-5.** Digital Control Inputs (B/GB, PGEB, SDAEN) Equivalent Inputs Schematics and ESD Protection

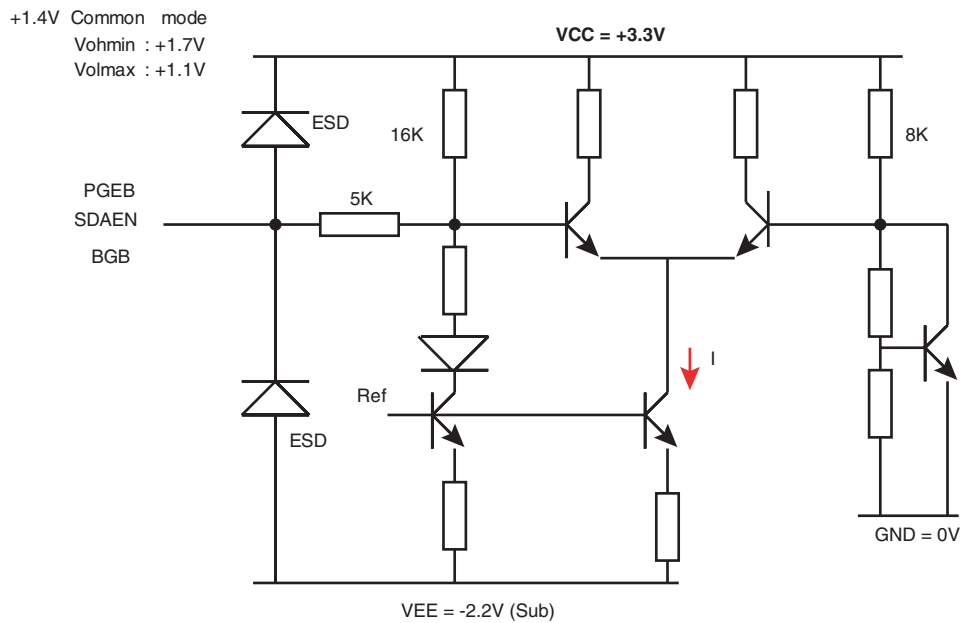
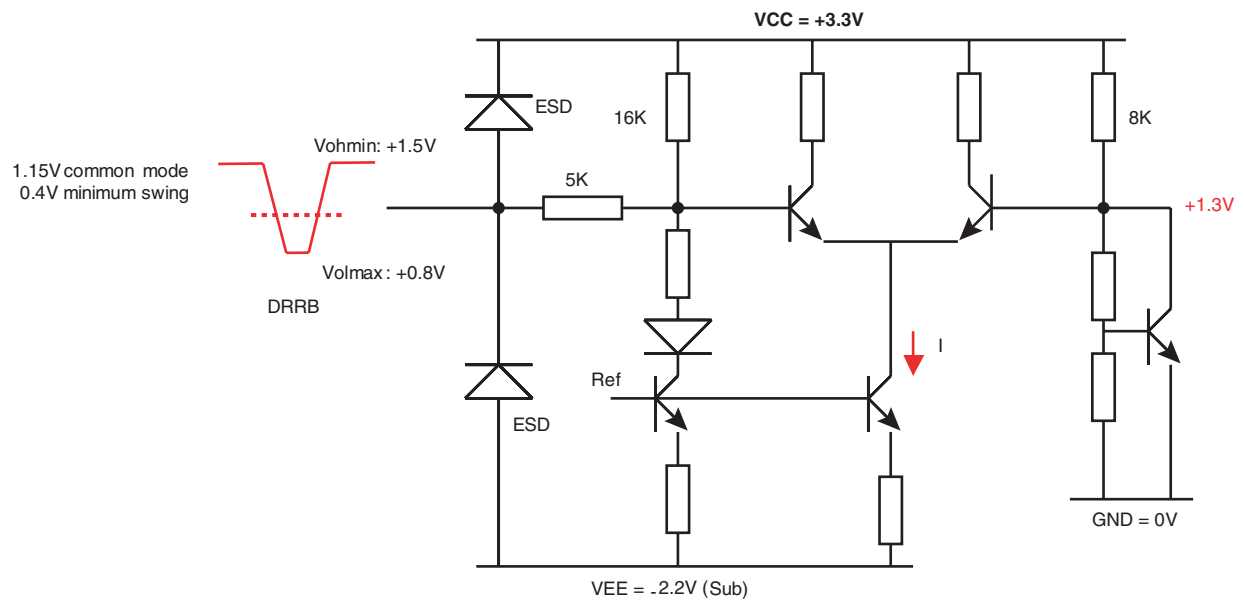

Figure 6-6. Data Ready (DRRB) Equivalent Input Schematic and ESD Protection



## 7. Definition of Terms

**Table 7-1.** Definition of Terms

| Term   |                                      | Description  |
|--------|--------------------------------------|--|
| Fs max | Maximum sampling frequency           | Sampling frequency for which ENOB < 6 bits   |
| Fs min | Minimum sampling frequency           | Sampling frequency for which the ADC Gain has fallen by 0.5dB with respect to the gain reference value. Performances are not guaranteed below this frequency   |
| BER    | Bit error rate                       | Probability to exceed a specified error threshold for a sample at maximum specified sampling rate. An error code is a code that differs by more than $\pm 32$ LSB from the correct code  |
| FPBW   | Full power input bandwidth           | Analog input frequency at which the fundamental component in the digitally reconstructed output waveform has fallen by 3 dB with respect to its low frequency value (determined by FFT analysis) for input at full-scale $-1$ dB ( $-1$ dBFS)  |
| SSBW   | Small signal input bandwidth         | Analog input frequency at which the fundamental component in the digitally reconstructed output waveform has fallen by 3 dB with respect to its low frequency value (determined by FFT analysis) for input at full-scale $-10$ dB ( $-10$ dBFS)  |
| SINAD  | Signal-to-noise and distortion ratio | Ratio expressed in dB of the RMS signal amplitude, set to 1dB below full-scale ( $-1$ dBFS), to the RMS sum of all other spectral components, including the harmonics except DC  |
| SNR    | Signal-to-noise ratio                | Ratio expressed in dB of the RMS signal amplitude, set to 1 dB below full-scale, to the RMS sum of all other spectral components excluding the nine first harmonics  |
| THD    | Total harmonic distortion            | Ratio expressed in dB of the RMS sum of the first nine harmonic components, to the RMS input signal amplitude, set at 1 dB below full-scale. It may be reported in dB (i.e, related to converter $-1$ dB full-scale), or in dBc (i.e, related to input signal level)   |
| SFDR   | Spurious-free dynamic range          | Ratio expressed in dB of the RMS signal amplitude, set at 1dB below full-scale, to the RMS value of the highest spectral component (peak spurious spectral component). The peak spurious component may or may not be a harmonic. It may be reported in dB (i.e., related to converter $-1$ dB full-scale), or in dBc (i.e, related to input signal level)  |
| ENOB   | Effective number of bits             | $ENOB = \frac{SINAD - 1.76 + 20 \log \frac{A}{F_s/2}}{6.02}$ Where A is the actual input amplitude and $F_s$ is the full-scale range of the ADC under test   |
| DNL    | Differential nonlinearity            | The Differential nonlinearity for an output code i is the difference between the measured step size of code i and the ideal LSB step size. DNL (i) is expressed in LSBs. DNL is the maximum value of all DNL (i). DNL error specification of less than 1 LSB guarantees that there are no missing output codes and that the transfer function is monotonic |
| INL    | Integral nonlinearity                | The Integral nonlinearity for an output code i is the difference between the measured input voltage at which the transition occurs and the ideal value of this transition. INL (i) is expressed in LSBs, and is the maximum value of all INL (i)   |
| TA     | Aperture delay                       | Delay between the rising edge of the differential clock inputs (CLK,CLKB) (zero crossing point), and the time at which (VIN,VINB) is sampled   |

Table 7-1. Definition of Terms (Continued)

| Term   |   | Description   |
|--------|---|---|
| JITTER | Aperture uncertainty                          | Sample to sample variation in aperture delay. The voltage error due to jitter depends on the slew rate of the signal at the sampling point  |
| TS     | Settling time                                 | Time delay to achieve 0.2% accuracy at the converter output when a 80% full-scale step function is applied to the differential analog input   |
| ORT    | Overvoltage recovery time                     | Time to recover 0.2% accuracy at the output, after a 150% full-scale step applied on the input is reduced to midscale   |
| TOD    | Digital data output delay                     | Delay from the rising edge of the differential clock inputs (CLK,CLKB) (zero crossing point) to the next point of change in the differential output data (zero crossing) with specified load  |
| TDR    | Data ready output delay                       | Delay from the falling edge of the differential clock inputs (CLK,CLKB) (zero crossing point) to the next point of change in the differential data ready output (zero crossing) with specified load   |
| TD1    | Time delay from data transition to data ready | General expression is $TD1 = TC1 + TDR - TOD$ with $TC = TC1 + TC2 = 1$ encoding clock period   |
| TD2    | Time delay from data ready to data            | General expression is $TD2 = TC2 + TDR - TOD$ with $TC = TC1 + TC2 = 1$ encoding clock period   |
| TC     | Encoding clock period                         | $TC1 =$ Minimum clock pulse width (high) $TC = TC1 + TC2$ $TC2 =$ Minimum clock pulse width (low)   |
| TPD    | Pipeline delay                                | Number of clock cycles between the sampling edge of an input data and the associated output data being made available, (not taking in account the TOD)  |
| TRDR   | Data ready reset delay                        | Delay between the falling edge of the data ready output asynchronous Reset signal (DDR <sub>B</sub> ) and the reset to digital zero transition of the data ready output signal (DR)   |
| TR     | Rise time                                     | Time delay for the output data signals to rise from 20% to 80% of delta between low level and high level  |
| TF     | Fall time                                     | Time delay for the output data signals to fall from 20% to 80% of delta between low level and high level  |
| PSRR   | Power supply rejection ratio                  | Ratio of input offset variation to a change in power supply voltage   |
| NRZ    | Nonreturn to zero                             | When the input signal is larger than the upper bound of the ADC input range, the output code is identical to the maximum code and the out-of-range bit is set to logic one. When the input signal is smaller than the lower bound of the ADC input range, the output code is identical to the minimum code, and the out-of-range bit is set to logic one. (It is assumed that the input signal amplitude remains within the absolute maximum ratings) |
| IMD    | Intermodulation distortion                    | The two tones intermodulation distortion (IMD) rejection is the ratio of either input tone to the worst third order intermodulation products  |
| NPR    | Noise power ratio                             | The NPR is measured to characterize the ADC performance in response to broad bandwidth signals. When applying a notch-filtered broadband white-noise signal as the input to the ADC under test, the Noise Power Ratio is defined as the ratio of the average out-of-notch to the average in-notch power spectral density magnitudes for the FFT spectrum of the ADC output sample test  |
| VSWR   | Voltage standing wave ratio                   | The VSWR corresponds to the ADC input insertion loss due to input power reflection. For example a VSWR of 1.2 corresponds to a 20 dB return loss (i.e. 99% power transmitted and 1% reflected)  |

## 8. EV10AS008B Application Information

### 8.1 Timing Information

#### 8.1.1 Timing Value for EV10AS008B

Timing values are defined in [Section 3.3](#). Timing values are given at package inputs/outputs, taking into account package transmission line, bond wire, pad and ESD protections capacitance, and specified termination loads.

Evaluation board propagation delays in 50Ω controlled impedance traces are not taken into account. Apply proper derating values corresponding to termination topology.

#### 8.1.2 Propagation Time Considerations

TOD and TDR timing values are given from package pin to pin and do not include the additional propagation times between device pins and input/output termination loads. For the evaluation board, the propagation time delay is 6.1 ps/mm (155 ps/inch) corresponding to 3.4 dielectric constant (at 10GHz) of the RO4003 used for the board.

If a different dielectric layer is used (for instance Teflon), please use appropriate propagation time values. TD1 and TD2 do not depend on propagation times because they are differential data ([See “Definition of Terms” on page 31.](#)).

TD1 and TD2 are also the most straightforward data to measure, because it is differential: TD can be measured directly onto termination loads, with matched oscilloscope probes.

#### 8.1.3 TOD – TDR Variation over Temperature

Values for TOD and TDR track each other over temperature (1 percent variation for TOD – TDR per 100 degrees Celsius temperature variation). Therefore TOD – TDR variation over temperature is negligible. Moreover, the internal (on chip) skews between each data TODs and TDR effect can be considered as negligible. Consequently, minimum values for TOD and TDR are never more than 100 ps apart. The same is true for the TOD and TDR maximum values.

However, external TOD – TDR values may be dictated by total digital data skews between every TODs (each digital data) and TDR: MCM board, bonding wires and output line length differences, and output termination impedance mismatches.

The external (on board) skew effect has not been taken into account for the specification of the minimum and maximum values for TOD – TDR.

#### 8.1.4 Principle of Operation

The analog input is sampled on the rising edge of external clock input (CLK,CLKB) after TA (aperture delay). The digitized data is available after 4 clock periods latency (pipeline delay (TPD)), on clock rising edge, after typical propagation delay TOD. The data ready differential output signal frequency (DR, DRB) is half the external clock frequency, it switches at the same rate as the digital outputs. The data ready output signal (DR, DRB) switches on external clock falling edge after a propagation delay TDR.

If TOD = TDR, the rising edge (True-False) of the differential data ready signal is placed in the middle of the output data valid window. This gives maximum setup and hold times for external data acquisition.

A Master asynchronous reset input command DRRB (active high) is available for initializing the differential data ready output signal (DR,DRB). This feature is mandatory in certain applications using

interleaved ADCs or using a single ADC with demultiplexed outputs. Without data ready signal initialization, it is impossible to store the output digital data in a defined order.

When used with e2v AT84CS001 1:2/1:4 10 bit DMUX, it is not required to initialize the data ready, as this device can start on either clock edge.

## 8.2 Principle of Data Ready Signal Control by DRRB Input Command

### 8.2.1 Data Ready Output Signal Reset

The data ready signal is reset on falling edge of DRRB input command. DRRB may also be connected to ground for data ready output signal Master Reset. As far as DRRB remains at logical low level the data ready output remains at logical zero (LVDS low) and is independent on the external free running encoding clock.

The data ready output signal (DR,DRB) is reset to logical zero (LVDS low) after TRDR.

TRDR is measured between the +1.15V point of the falling edge of DRRB input command and the zero crossing point of the differential data ready output signal (DR,DRB). The data ready Reset command may be a pulse of 1 ns minimum time width.

### 8.2.2 Data Ready Output Signal Restart

The Data Ready output signal restarts on DRRB command rising edge, logical high levels.

DRRB may also be connected to 3.3V for normal free running of the Data Ready output signal. The Data Ready signal restart sequence depends on the logical level of the external encoding clock, at DRRB rising edge instant:

1. The DRRB rising edge occurs when the external encoding clock input (CLK,CLKB) is low: the Data Ready output first rising edge occurs after half a clock period on the clock falling edge, after a typical delay time  $TDR = 360$  ps already defined here above.
2. The DRRB rising edge occurs when the external encoding clock input (CLK,CLKB) is high: the Data Ready output first rising edge occurs after one clock period on the clock falling edge, and a delay  $TDR = 360$  ps.

Consequently, as the analog input is sampled on the clock rising edge, the first digitized data corresponding to the first acquisition (N) after Data Ready signal restart (rising edge) is always strobed by the third rising edge of the data ready signal.

The time delay (TD1) is specified between the last point of a change in the differential output data (zero crossing point) to the rising or falling edge of the differential Data Ready signal (DR,DRB) (zero crossing point).

**Note:** For normal initialization of Data Ready output signal, the external encoding clock signal frequency and level must be controlled.

It is reminded that the minimum encoding clock sampling rate for the ADC is 200 Msps, due to internal T/H droop rate. Consequently the clock cannot be stopped without corrupting the current held data.

8.2.3 Timing Diagram with Data Ready Reset

Figure 8-1. EV10AS008B Timing Diagram (2 Gbps Clock Rate) Data Ready Reset, Clock Held at Low Level

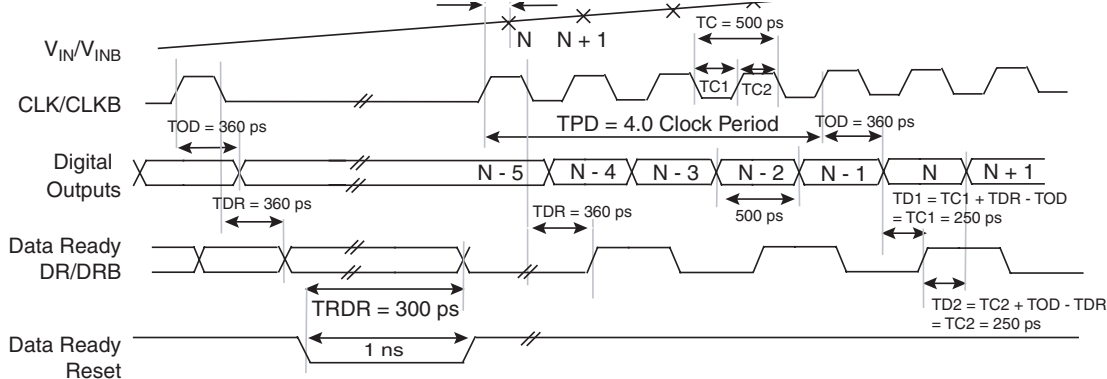
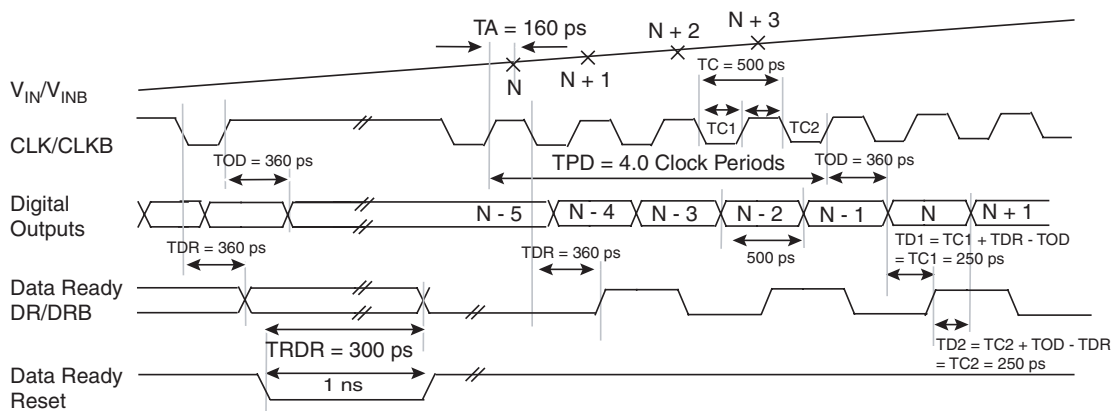

Figure 8-2. EV10AS008B Timing Diagram (2 Gbps Clock Rate) Data Ready Reset, Clock Held at High Level



### 8.3 Analog Inputs (VIN/VINB)

#### 8.3.1 Static Issues: Differential vs. Single-ended (Full-scale Inputs)

The ADC front-end Track and Hold differential preamplifier has been designed in order to be entered either in differential mode or single-ended mode, up to maximum operating speed (2.2 Gsps), without affecting dynamic performance (does not request a single to differential balun). In single-ended input configuration, the in-phase full-scale input amplitude is 0.5V peak-to-peak, centered on 0V. (or  $-2$  dBm into  $50\Omega$ ).

**Figure 8-3.** Typical Single-ended Analog Input Configuration (Full-scale)

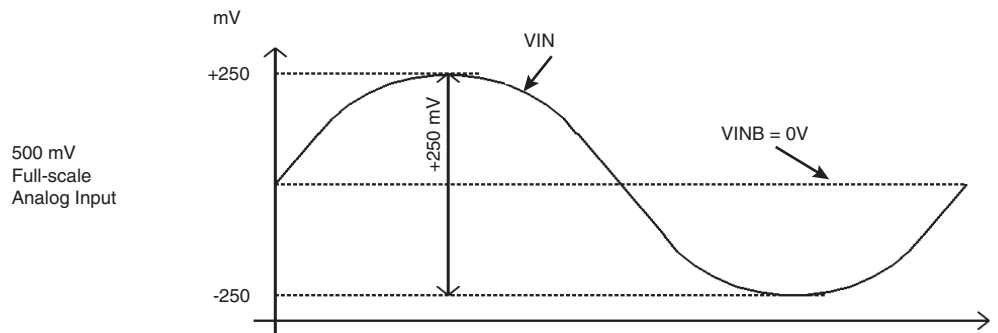

The analog input full-scale range is 0.5V peak-to-peak (Vpp), or  $-2$  dBm into the  $50\Omega$  ( $100\Omega$  differential) termination resistor.

In differential mode input configuration, that means 0.25V on each input, or  $\pm 125$  mV around zero volt. The input common mode is ground.

**Figure 8-4.** Differential Inputs Voltage Span (Full-scale)

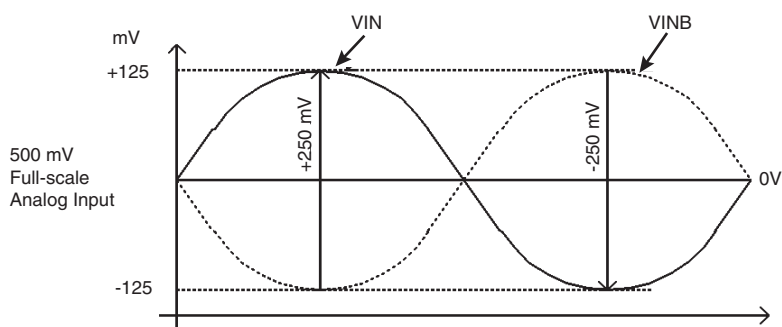

#### 8.3.2 Dynamic Issues: Input Impedance and VSWR

The EV10AS008B analog input features a  $100\Omega$  ( $\pm 2\%$ ) differential input impedance ( $2 \times 50\Omega // 0.3$  pF); Each analog input (VIN, VINB) is terminated by on chip  $50\Omega$  single-ended ( $100\Omega$  differential) resistors ( $\pm 2\%$  matching). The ADC package Analog Inputs transmission lines feature a  $50\Omega$  controlled impedance. Each single-ended die input pad capacitance (taking into account ESD protection) is 0.3 pF. This leads to a global input VSWR (including ball, package and bounding) of less than 1.2 from DC up to 2.5 GHz.

## 8.4 Clock Inputs (CLK/CLKB)

The EV10AS008B clock inputs are designed for either single-ended or differential operation. The EV10AS008B clock inputs are on-chip  $100\Omega$  ( $2 \times 50\Omega$ ) differentially terminated. Termination mid point is AC coupled to ground through  $40\text{ pF}$  on-chip capacitor. Therefore either ground or different common modes could be used (ECL, LVDS).

However logic ECL or LVDS square wave clock generators are not recommended because of poor jitter performances.

Furthermore, the propagation times of the biasing tees used to offset the common mode voltage to ECL or LVDS levels may not match. A very low phase noise (low jitter) sinewave input signal should be used for enhanced SNR performance, when digitizing high frequency analog inputs.

Typically, using a sinewave oscillator featuring  $-135\text{ dBc/Hz}$  phase noise, at  $20\text{ KHz}$  from carrier, a global jitter value (including ADC + generator) of less than  $200\text{ fs}$  RMS has been measured. If clock signal frequency is at fixed rates, it is recommended to narrow band filter the clock signal to improve jitter performance.

But driving the clock input in single ended may perturb the chip ground plane, (since termination mid point is AC coupled to chip ground plane). Therefore, it is recommended to drive the clock input in differential, for minimum chip ground plane perturbation ( $4\text{ dBm}$  max operating recommended). The minimum operating clock input power is  $-1\text{ dBm}$  (equivalent to  $\pm 100\text{ mV}$  minimum swing on each clock input), to avoid SNR performances degradations linked to clock signal slew rate. A single to differential balun with  $\sqrt{2}$  ratio may be used (featuring  $50\Omega$  input impedance with  $100\Omega$  differential termination).

Recommended clock inputs common mode is ground.

### 8.4.1 Differential Clock Inputs Voltage Levels ( $4\text{ dBm}$ differential on $100\Omega$ Recommended)

**Figure 8-5.** Differential Clock Inputs (Ground Common Mode): Recommended

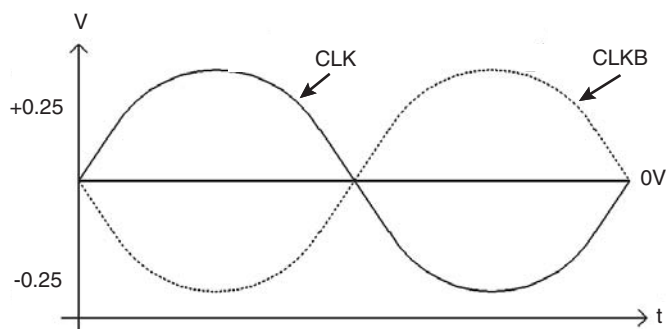

### 8.4.2 Equivalent Single-ended Clock Inputs Voltage Levels (1 dBm Single ended on 50Ω Recommended)

**Figure 8-6.** Single-ended Clock Input (Ground Common Mode)

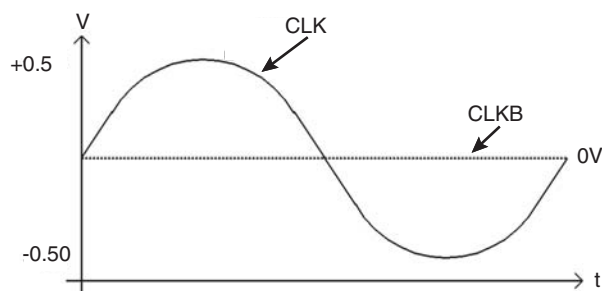

## 8.5 Noise Immunity Information

Circuit noise immunity performance begins at design level.

Efforts have been made on the design in order to make the device as insensitive as possible to chip environment perturbations resulting from the circuit itself or induced by external circuitry (cascode stages isolation, internal damping resistors, clamps, internal on chip decoupling capacitors).

Furthermore, the fully differential operation from analog input up to the digital outputs provides enhanced noise immunity by efficient common mode noise rejection. Common mode noise voltage induced on the differential analog and clock inputs will be cancelled out by these balanced differential amplifiers.

Moreover, proper active signals shielding has been provided on the chip to reduce the amount of coupled noise on the active inputs: The analog inputs and clock inputs of the EV10AS008B device have been surrounded by ground pins, which must be directly connected to the external ground plane.

## 8.6 Digital Outputs: Termination and Logic Compatibility

The EV10AS008B output buffers are designed to drive 50Ω controlled impedance lines properly terminated by a 50Ω resistor. A 10.5 mA bias current flowing alternately into one of the 50Ω resistors when switching ensures a 0.25V single-ended voltage drop across the resistor (0.5V differential)

Each single-ended output transmission line length must be kept identical (keep < 3 mm). Mismatches in the differential line lengths may cause output differential common mode variation.

It is recommended to bypass the midpoint of the differential 100Ω termination with a 47 pF capacitor to avoid common mode perturbation in case of slight mismatch in the differential output line lengths.

See recommended-termination scenarios here below.

- For LVDS digital output logic compatibility,  $V_{PLUSD}$  should be tied to 2.5V ( $\pm 75$  mV).

8.6.1 LVDS Differential Output Loading Configurations

Figure 8-7. 50Ω Terminated Differential Outputs

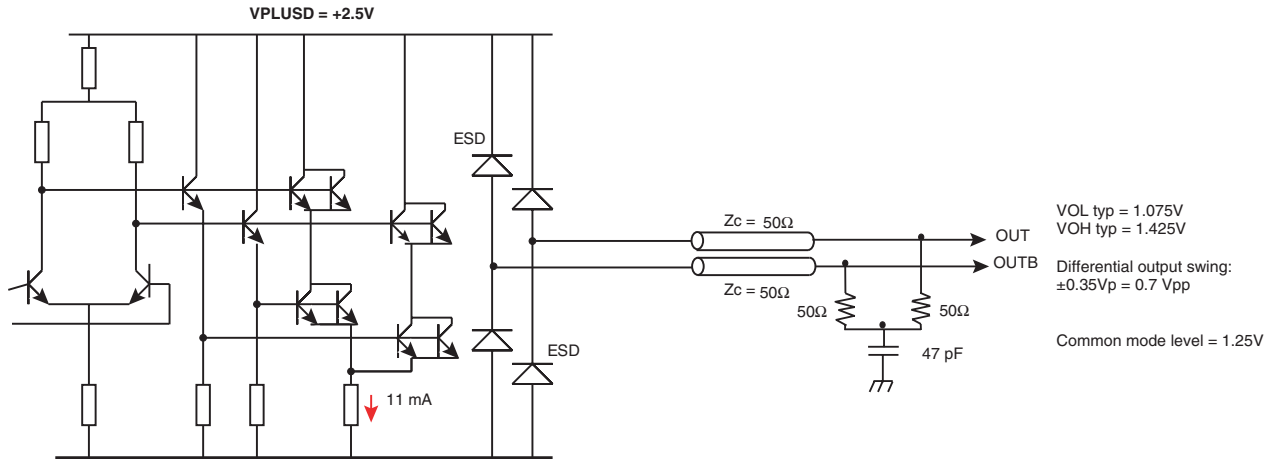

8.6.2 LVDS Logic Compatibility

Figure 8-8. LVDS Format (cf. IEEE Std 1596.3- 1994): (1125 mV < common mode < 1375 mV) and 250 mV < Output swing < 450 mV

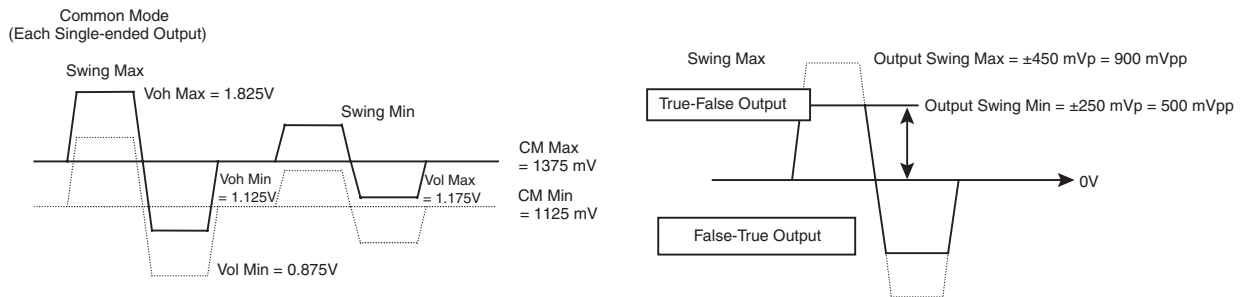

## 8.7 ADC Main Functions

### 8.7.1 Out-of-range Bit (OR/ORB)

It goes to logical high state when the input exceeds the positive full-scale or falls below the negative full-scale. When the analog input exceeds the positive full-scale, the digital outputs remain at high logical state, with (OR,ORB) at logical one. When the analog input falls below the negative full-scale, the digital outputs remain at logical low state, with (OR,ORB) at logical one again.

### 8.7.2 Bit Error Rate (BER)

The EV10AS008B internal regeneration latches indecision (for inputs very close to latches threshold) may produce errors in the logic encoding circuitry and leading to large amplitude output errors.

This is due to the fact that the latches are regenerating the internal analog residues into logical states with a finite voltage gain value ( $A_v$ ) within a given positive amount of time  $D(t)$ :

$A_v = \exp(D(t)/\tau)$ , with  $\tau$  the positive feedback regeneration time constant. By default  $D(t)$  is equal to half a clock period.

The EV10AS008B has been designed for reducing the probability of occurrence of such errors to  $10^{-15}$  at 2.2 Gsps.

### 8.7.3 Gray or Binary Output Data Format Select

It is possible for the user to choose between the binary or Gray output data format.

Digital Data format selection:

BINARY output format if B/GB is floating or GND.

Gray output format if B/GB is connected to  $V_{CC} = +3.3V$ .

### 8.7.4 Pattern Generator Function

The Pattern Generator function (enabled by connecting pin A9 PGEB to  $V_{CC} = +3.3V$ ) allows to check rapidly the ADC operation thanks to a checker board pattern delivered internally to the ADC. Each output bit of the ADC should toggle from 0 to 1 successively, giving sequences such as 0101010101 (strobed by falling edge of DR) and 1010101010 (strobed by rising edge of DR) every 2 clock cycles.

### 8.7.5 Diode: Junction Temperature Monitoring

The diode pin is provided for junction temperature monitoring. If the user does not intend to use the die junction temperature monitoring function, the diode pin (A10) has to be left either floating or connected to ground.

Because of the use of one internal diode-mounted transistor (used for junction temperature monitoring), the user has to implement external head-to-tail protection diodes to avoid potential reverse currents flows which may damage the internal diode component.

**Figure 8-9.** Diode Pin implementation of Die Junction Temperature Monitoring Function Only

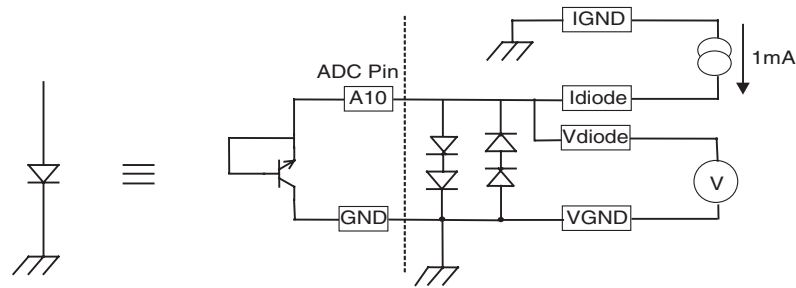

**Figure 8-10.** Junction Temperature Diode Transfer Function

The forward voltage drop, (VDIODE) across diode component, vs. junction temperature, (including chip parasitic resistance), is given below (IDIODE = 1 mA):

(To be revised)

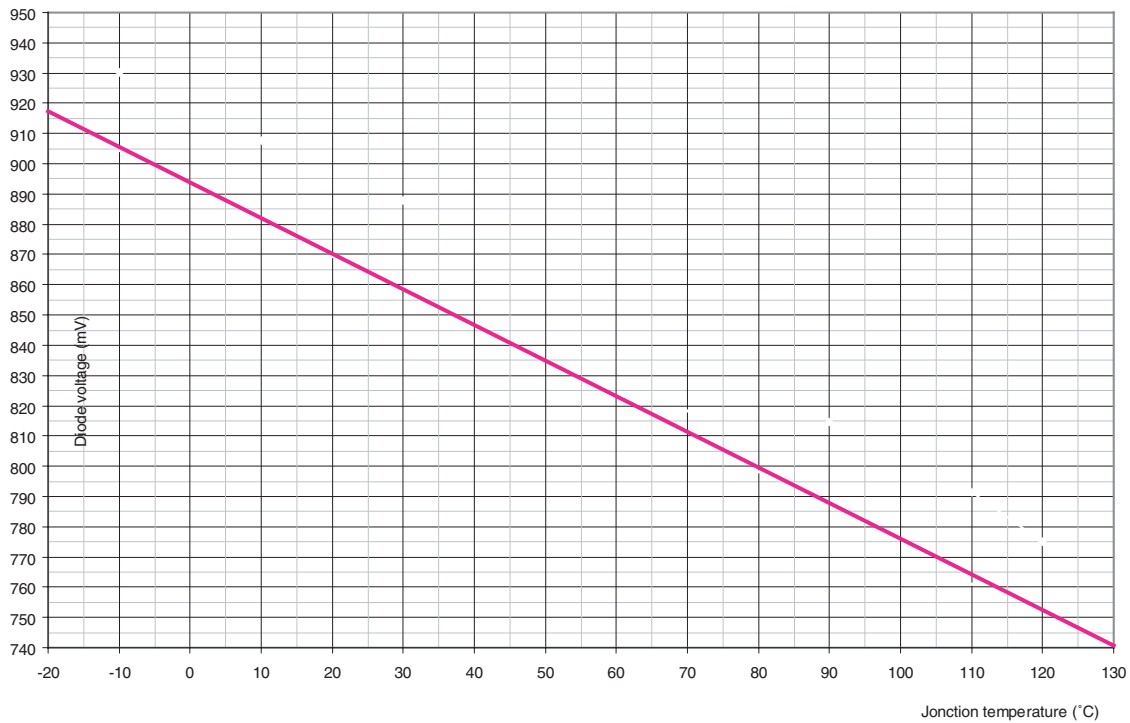

Note: The operating die junction temperature must be kept below 125°C, to ensure long term device reliability.

### 8.7.6 ADC Gain Control

The ADC gain is adjustable by the means of the pin R9 of CBGA package.

**Figure 8-11.** Gain Adjust Transfer Function

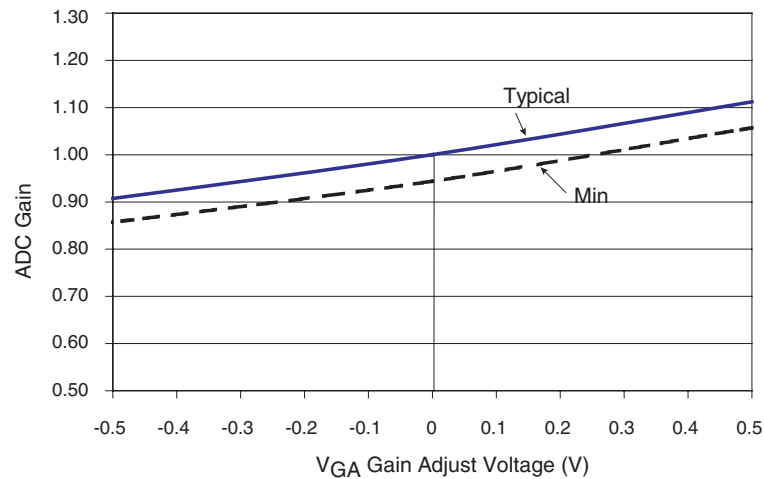

### 8.7.7 Sampling Delay Adjust

Sampling delay adjust (SDA pin) allows to fine tune the sampling ADC aperture delay TAD around its nominal value. This functionality is enabled thanks to the SDAEN signal, which is active when tied to V<sub>CC</sub> and inactive when tied to GND.

This feature is particularly interesting for interleaving ADCs to increase sampling rate.

The variation of the delay around its nominal value as a function of the SDA voltage is shown in the following graph (simulation result):

**Figure 8-12.** Typical Tuning Range is  $\pm 45$  ps for Applied Control Voltage Varying Between  $-0.5$ V to  $0.5$ V on SDA Pin

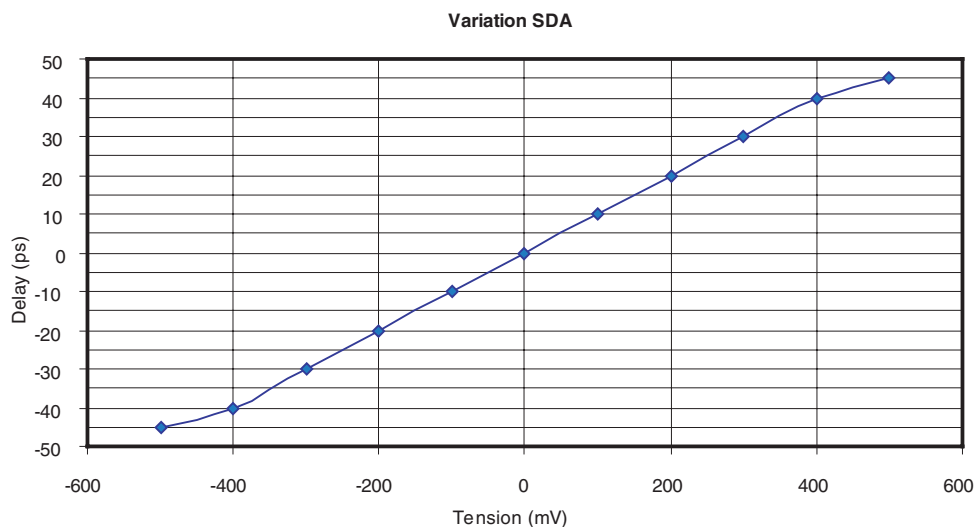

Note: The variation of the delay in function of the temperature is negligible.

## 9. Ordering Information

| Part Number     | Package      | Temperature Range  | Screening Level | Comments         |
|-----------------|--------------|--|-----------------|------------------|
| EVX10AS008BGL   | CBGA152      | Ambient  | Prototype       |                  |
| EV10AS008BCGL   | CBGA152      | Commercial C grade<br>$0^{\circ}\text{C} < T_C, T_J < 90^{\circ}\text{C}$    | Standard        |                  |
| EV10AS008BVGL   | CBGA152      | Industrial V grade<br>$-20^{\circ}\text{C} < T_C, T_J < 110^{\circ}\text{C}$ | Standard        |                  |
| EV10AS008BMGS   | CI-CGA152    | Military M grade<br>$-55^{\circ}\text{C} < T_C, T_J < 125^{\circ}\text{C}$   | Standard        |                  |
| EVX10AS008BGLY  | CBGA152 RoHS | Ambient  | Prototype       |                  |
| EV10AS008BCGLY  | CBGA152 RoHS | Commercial C grade<br>$0^{\circ}\text{C} < T_C, T_J < 90^{\circ}\text{C}$    | Standard        |                  |
| EV10AS008BVGLY  | CBGA152 RoHS | Industrial V grade<br>$-20^{\circ}\text{C} < T_C, T_J < 110^{\circ}\text{C}$ | Standard        |                  |
| EV10AS008BGL-EB | CBGA152      | Ambient  | Prototype       | Evaluation board |

## 10. Appendices

### Datasheet Status

| Status   |   | Validity                                 |
|--|---|--|
| Objective specification  | This datasheet contains target and goal specifications for discussion with the client and application validation                | Before design phase                      |
| Target specification   | This datasheet contains target and goal specifications for product development  | Valid during the design phase            |
| Preliminary specification Alpha-site   | This datasheet contains preliminary data. Additional data may be published on a later date and could include simulation results | Valid before the characterization phase  |
| Preliminary specification Beta-site  | This datasheet also contains characterization results   | Valid before the industrialization phase |
| Product specification  | This datasheet contains final product specifications  | Valid for production purposes            |
| <b>Limiting Values</b>   |   |  |
| Limiting values given are in accordance with the Absolute Maximum Rating System (IEC 134). Stress above one or more of the limiting values may cause permanent damage to the device. These are stress ratings only and operation of the device at these or at any other conditions above those given in the characteristics sections of the specification is not implied. Exposure to limiting values for extended periods may affect device reliability |   |  |
| <b>Application Information</b>   |   |  |
| Where application information is given, it is advisory and does not form part of the specification   |   |  |

### 10.1 Life Support Applications

These products are not designed for use in life support appliances, devices or systems where malfunction of these products can reasonably be expected to result in personal injury. e2v customers using or selling these products for use in such applications do so at their own risk and agree to fully indemnify e2v for any damages resulting from improper use or sale.

## Table of Contents

|           |  |           |
|-----------|--|-----------|
| <b>1</b>  | <b><i>Description</i></b> .....  | <b>2</b>  |
|           | 1.1 Ascending Compatibility with AT84AS008 .....                       | 3         |
| <b>2</b>  | <b><i>Functional Description</i></b> .....                             | <b>4</b>  |
| <b>3</b>  | <b><i>Specifications</i></b> .....                                     | <b>4</b>  |
|           | 3.1 Absolute Maximum Ratings .....                                     | 4         |
|           | 3.2 Recommended Conditions of Use .....                                | 5         |
|           | 3.3 Electrical Characteristics .....                                   | 6         |
|           | 3.4 Explanation of Test Levels .....                                   | 10        |
|           | 3.5 Functions Description .....  | 11        |
|           | 3.6 Timing Diagram .....   | 12        |
|           | 3.7 Coding .....   | 13        |
| <b>4</b>  | <b><i>Pin Description</i></b> .....                                    | <b>14</b> |
|           | 4.1 Package Description .....  | 17        |
| <b>5</b>  | <b><i>Thermal and Moisture Characteristics</i></b> .....               | <b>24</b> |
|           | 5.1 Dissipation by Conduction and Convection (CBGA 152) .....          | 24        |
|           | 5.2 Thermal Dissipation by Conduction Only (CBGA 152) .....            | 25        |
|           | 5.3 Dissipation by Conduction and Convection (CI-CGA 152) .....        | 25        |
| <b>6</b>  | <b><i>Equivalent Input/Output Schematics</i></b> .....                 | <b>27</b> |
| <b>7</b>  | <b><i>Definition of Terms</i></b> .....                                | <b>31</b> |
| <b>8</b>  | <b><i>EV10AS008B Application Information</i></b> .....                 | <b>33</b> |
|           | 8.1 Timing Information .....   | 33        |
|           | 8.2 Principle of Data Ready Signal Control by DRRB Input Command ..... | 34        |
|           | 8.3 Analog Inputs (VIN/VINB) .....                                     | 36        |
|           | 8.4 Clock Inputs (CLK/CLKB) .....                                      | 37        |
|           | 8.5 Noise Immunity Information .....                                   | 38        |
|           | 8.6 Digital Outputs: Termination and Logic Compatibility .....         | 38        |
|           | 8.7 ADC Main Functions .....   | 40        |
| <b>9</b>  | <b><i>Ordering Information</i></b> .....                               | <b>43</b> |
| <b>10</b> | <b><i>Appendices</i></b> .....   | <b>44</b> |
|           | 10.1 Life Support Applications .....                                   | 44        |



## How to reach us

Home page: [www.e2v.com](http://www.e2v.com)

### Sales offices:

#### Europe Regional sales office

##### e2v ltd

106 Waterhouse Lane  
Chelmsford  
Essex CM1 2QU  
England  
Tel: +44 (0)1245 493493  
Fax:: +44 (0)1245 492492  
mailto: [enquiries@e2v.com](mailto:enquiries@e2v.com)

#### Europe Regional sales office

##### e2v sas

16 Burospace  
F-91572 Bièvres  
Cedex  
France  
Tel: +33 (0) 16019 5500  
Fax: +33 (0) 16019 5529  
mailto: [enquiries-fr@e2v.com](mailto:enquiries-fr@e2v.com)

#### Europe Regional sales office

##### e2v gmbh

Industriestraße 29  
82194 Gröbenzell  
Germany  
Tel: +49 (0) 8142 41057-0  
Fax:: +49 (0) 8142 284547  
mailto: [enquiries-de@e2v.com](mailto:enquiries-de@e2v.com)

#### Americas

##### e2v inc

4 Westchester Plaza  
Elmsford  
NY 10523-1482  
USA  
Tel: +1 (914) 592 6050 or  
1-800-342-5338,  
Fax:: +1 (914) 592-5148  
mailto: [enquiries-na@e2v.com](mailto:enquiries-na@e2v.com)

#### Asia Pacific

##### e2v ltd

11/F.,  
Onfem Tower,  
29 Wyndham Street, Central,  
Hong Kong  
Tel: +852 3679 364 8/9  
Fax: +852 3583 1084  
mailto: [enquiries-ap@e2v.com](mailto:enquiries-ap@e2v.com)

#### Product Contact:

##### e2v

Avenue de Rochepleine  
BP 123 - 38521 Saint-Egrève Cedex  
France  
Tel: +33 (0)4 76 58 30 00

##### Hotline:

mailto: [hotline-bdc@e2v.com](mailto:hotline-bdc@e2v.com)

Whilst e2v has taken care to ensure the accuracy of the information contained herein it accepts no responsibility for the consequences of any use thereof and also reserves the right to change the specification of goods without notice. e2v accepts no liability beyond that set out in its standard conditions of sale in respect of infringement of third party patents arising from the use of tubes or other devices in accordance with information contained herein.