

Document No.	853-0639
ECN No.	99799
Date of Issue	June 14, 1990
Status	Product Specification
ECL Products	

# 10103

## Gate

Quad 2-Input OR (3 OR and 1 OR/NOR) Gate

### FEATURES

- Typical propagation delay: 2.0ns
- Typical supply current ( $-I_{EE}$ ): 21mA

### DESCRIPTION

The 10103 is a Quad 2-Input 3 OR and 1 OR/NOR gate. All unused inputs can be left open due to integrated pull-down resistors which avoid the need for a supply voltage.

### ORDERING INFORMATION

DESCRIPTION	ORDER CODE
16-Pin Plastic DIP	10103N
16-Pin Ceramic DIP	10103F

### PIN CONFIGURATION

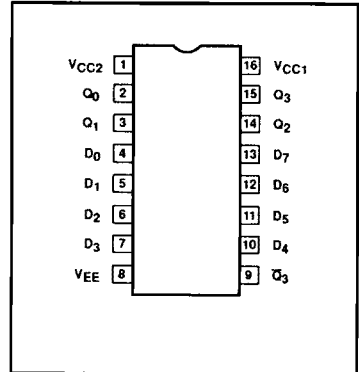

### PIN DESCRIPTION

PINS	DESCRIPTION
D <sub>0</sub> - D <sub>7</sub>	Data Inputs
Q <sub>0</sub> - Q <sub>3</sub>	Data Outputs (OR)
$\bar{Q}_3$	Data Output (NOR)

### LOGIC DIAGRAM

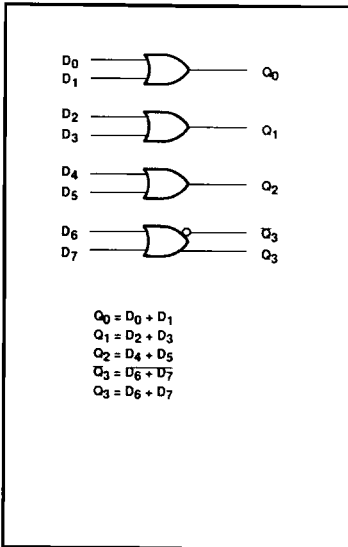

### SIMPLIFIED SCHEMATIC

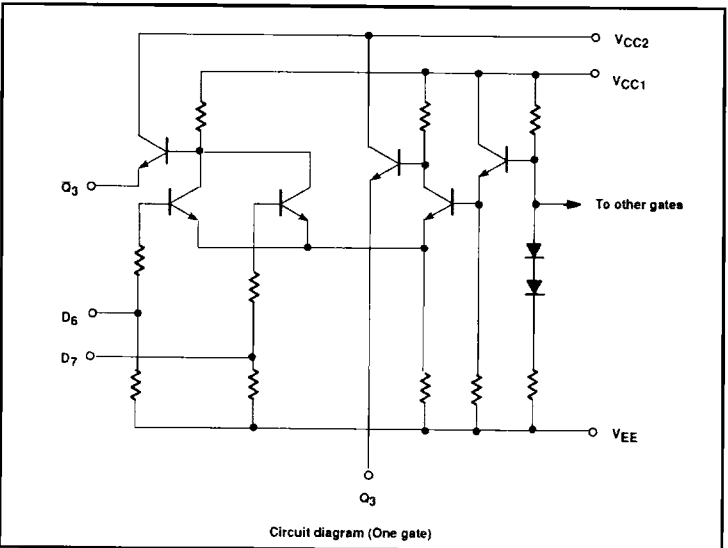

## Gate

10103

## ABSOLUTE MAXIMUM RATINGS

SYMBOL	PARAMETER	LIMITS	UNIT	
$V_{EE}$	Supply voltage	-8.0	V	
$V_{IN}$	Input voltage ( $V_{IN}$ should never be more negative than $V_{EE}$ )	0 to $V_{EE}$	V	
$I_O$	Output source current (continuous)	-50	mA	
$T_S$	Storage temperature range	-55 to +150	°C	
$T_J$	Maximum junction temperature	Ceramic Package	+165	°C
		Plastic Package	+150	°C

## NOTE:

Operation beyond the limits set forth in this table may impair the useful life of the device. Unless otherwise noted, these limits are specified over the operating ambient temperature range.

## DC OPERATING CONDITIONS

SYMBOL	PARAMETER	TEST CONDITIONS	LIMITS			UNIT
			MIN.	NOM.	MAX.	
$V_{CC1}, V_{CC2}$	Circuit ground		0	0	0	V
$V_{EE}$	Supply voltage (negative)			-5.2		V
$V_{IH}$	High level input voltage	$T_A = -30^\circ\text{C}$			-890	mV
		$T_A = +25^\circ\text{C}$			-810	mV
		$T_A = +85^\circ\text{C}$			-700	mV
$V_{IHT}$	High level input threshold voltage	$T_A = -30^\circ\text{C}$	-1205			mV
		$T_A = +25^\circ\text{C}$	-1105			mV
		$T_A = +85^\circ\text{C}$	-1035			mV
$V_{ILT}$	Low level input threshold voltage	$T_A = -30^\circ\text{C}$			-1500	mV
		$T_A = +25^\circ\text{C}$			-1475	mV
		$T_A = +85^\circ\text{C}$			-1440	mV
$V_{IL}$	Low level input voltage	$T_A = -30^\circ\text{C}$	-1890			mV
		$T_A = +25^\circ\text{C}$	-1850			mV
		$T_A = +85^\circ\text{C}$	-1825			mV
$T_A$	Operating ambient temperature range		-30	+25	+85	°C

## NOTE:

When operating at other than the specified  $V_{EE}$  voltage (-5.2V), the DC and AC Electrical Characteristics will vary slightly from specified values.

## Gate

10103

**DC ELECTRICAL CHARACTERISTICS**  $V_{CC1} = V_{CC2} = \text{ground}$ ,  $V_{EE} = -5.2V \pm 0.010V$ ,  $T_A = -30^\circ\text{C}$  to  $+85^\circ\text{C}$  output loading  $50\Omega$  to  $-2.0V \pm 0.010V$  unless otherwise specified<sup>1,3</sup>

SYMBOL	PARAMETER	TEST CONDITIONS <sup>2</sup>		LIMITS			UNIT
				MIN.	TYP.	MAX.	
$V_{OH}$	High level output voltage	$T_A = -30^\circ\text{C}$	For $Q_n$ outputs, apply $V_{IHMAX}$ to	-1060		-890	mV
		$T_A = +25^\circ\text{C}$	all inputs. For $Q_3$ output, apply	-960		-810	mV
		$T_A = +85^\circ\text{C}$	$V_{ILMIN}$ to all inputs.	-890		-700	mV
$V_{OHT}$	High level output threshold voltage	$T_A = -30^\circ\text{C}$	For $Q_n$ outputs, apply $V_{IHT}$ to one gate input	-1080			mV
		$T_A = +25^\circ\text{C}$	with $V_{ILMIN}$ applied to the other gate input. For $Q_3$ output, apply $V_{ILT}$ to one gate input	-980			mV
		$T_A = +85^\circ\text{C}$	with $V_{ILMIN}$ applied to the other gate input.	-910			mV
$V_{OLT}$	Low level output threshold voltage	$T_A = -30^\circ\text{C}$	For $Q_n$ outputs, apply $V_{ILT}$ to one gate input			-1655	mV
		$T_A = +25^\circ\text{C}$	with $V_{ILMIN}$ applied to the other gate input. For $Q_3$ output, apply $V_{IHT}$ to one gate input			-1630	mV
		$T_A = +85^\circ\text{C}$	with $V_{ILMIN}$ applied to the other gate input.			-1595	mV
$V_{OL}$	Low level output voltage	$T_A = -30^\circ\text{C}$	For $Q_n$ outputs, apply $V_{ILMIN}$ to	-1890		-1675	mV
		$T_A = +25^\circ\text{C}$	all inputs. For $Q_3$ output, apply	-1850		-1650	mV
		$T_A = +85^\circ\text{C}$	$V_{IHMAX}$ to all inputs.	-1825		-1615	mV
$I_{IH}$	High level input current	$T_A = -30^\circ\text{C}$	Apply $V_{IHMAX}$ to each input under test,			390	$\mu\text{A}$
		$T_A = +25^\circ\text{C}$	one at a time, with $V_{ILMIN}$ applied			245	$\mu\text{A}$
		$T_A = +85^\circ\text{C}$	to all other inputs.			245	$\mu\text{A}$
$I_{IL}$	Low level input current	$T_A = -30^\circ\text{C}$	Apply $V_{ILMIN}$ to each input under test,	0.5			$\mu\text{A}$
		$T_A = +25^\circ\text{C}$	one at a time, with $V_{IHMAX}$ applied	0.5			$\mu\text{A}$
		$T_A = +85^\circ\text{C}$	to all other inputs.	0.3			$\mu\text{A}$
$-I_{EE}$	$V_{EE}$ supply current	$T_A = -30^\circ\text{C}$				29	mA
		$T_A = +25^\circ\text{C}$		21	26		mA
		$T_A = +85^\circ\text{C}$				29	mA
$\frac{\Delta V_{OH}}{\Delta V_{EE}}$	High level output voltage compensation	$T_A = +25^\circ\text{C}$			0.016		V/V
$\frac{\Delta V_{OL}}{\Delta V_{EE}}$	Low level output voltage compensation				0.250		V/V
$\frac{\Delta V_{BB}}{\Delta V_{EE}}$	Reference bias voltage compensation				0.148		V/V

**NOTES:**

- The specified limits represent the worst case values for the parameter. Since these worst case values normally occur at the supply voltage and temperature extremes, additional noise immunity can be achieved by decreasing the allowable operating condition ranges.
- Conditions for testing shown in the tables are not necessarily worst case. For worst case testing guidelines, refer to DC Testing, Chapter 1, Section 3.
- The specified limits shown in the DC Electrical Characteristics table can be met only after thermal equilibrium has been established. Thermal equilibrium is established by applying power for at least 2 minutes, while maintaining transverse airflow of 2.5 meters/sec (500 linear feet/min) over the device, mounted either in a test socket or on a printed circuit board. Test voltage values are given in the DC Operating Conditions table.

Gate

10103

AC ELECTRICAL CHARACTERISTICS  $V_{CC1} = V_{CC2} = \text{ground}, V_{EE} = -5.2V \pm 0.010V$

SYMBOL	PARAMETER	TEST CONDITION	LIMITS							UNIT
			$T_A = -30^\circ\text{C}$		$T_A = +25^\circ\text{C}$			$T_A = +85^\circ\text{C}$		
			MIN.	MAX.	MIN.	TYP.	MAX.	MIN.	MAX.	
$t_{PLH}$ $t_{PHL}$	Propagation delay $D_n$ to $Q_n, \bar{Q}_3$	Waveform 1	1.00	3.10	1.00	2.00	2.90	1.00	3.30	ns
$t_{TLH}$ $t_{THL}$	Transition time 20% to 80%, 80% to 20%	Waveform 1	1.10	3.60	1.10	2.00	3.30	1.10	3.70	ns

NOTE:

For AC test setup information, see AC Testing, Chapter 2, Section 3.

AC WAVEFORMS

