

DUAL SIDE-BY-SIDE PULSE TRANSFORMERS

FEATURES

- **Built and Tested to MIL-PRF-21038 & MIL-STD-202**
 - M-Level Screening (Standard)
 - T-Level Screening (Optional)
- **Surface Mount Configurations**
 - Tape and Reel Available
- **Available in 3.3, 5, 12 & 15 Volt Ratios**
- **For use with MIL-STD-1553A & B, MacAir A-5690, A-5232, A-3818, & A-4905**
- **-55°C to +130°C Operating Temperature Range**
- **Peak Reflow Temperature 225°C**
- **Available RoHS Compliant**



DESCRIPTION AND APPLICATIONS

The DSS-1000 Series of transformers are dual, side-by-side pulse transformers that provide the turns ratio configurations, component isolation, and common mode rejection ratio characteristics necessary for MIL-STD-1553 Data Bus specification compliance. These versatile pulse transformers meet all the electrical requirements of Manchester II serial bi-phase data transmission.

The step-up and step-down ratios available with the DSS series complement Data Device Corporation's (DDC's) entire MIL-STD-1553 line. These transformers are low-profile, modular units that are multi-tapped to accommodate existing system configurations. To meet the rugged demands of airborne and ground based military applications, they are encapsulated in accordance with MIL-PRF-21038. Sinusoidal or trapezoidal waveforms are transmitted with minimal distortion, making the DSS Series an excellent choice for any MIL-STD-1553A or B application.

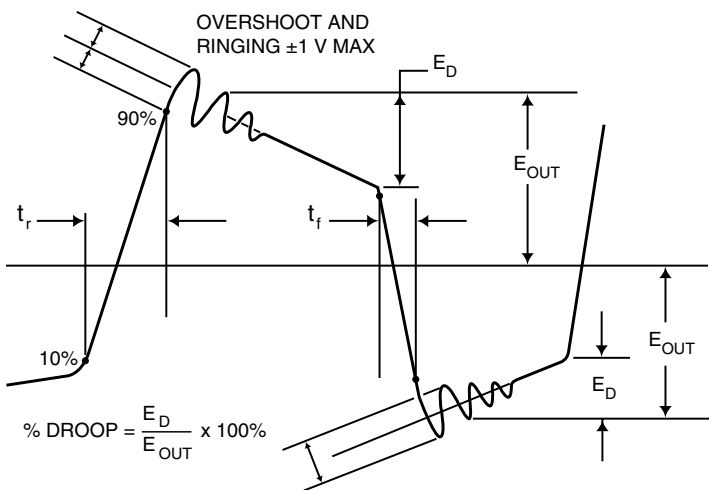

FIGURE 1. WAVEFORM INTEGRITY

Note:

1. Input to be applied and output to be measured for all dash numbers are shown. N represents highest turns winding in each test.
2. For DSS-1003, the 360 ohm resistor in Figure 3 is replaced with a 50 ohm resistor for conducting the waveform test.

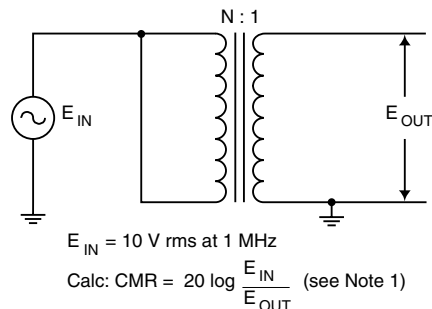
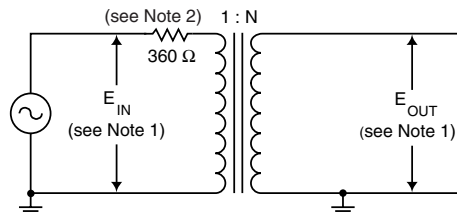

FIGURE 2. CIRCUIT FOR COMMON MODE REJECTION



E_{IN} = 250 kHz square wave, 27.0 volts peak-to-peak with a rise and fall time no greater than 100 ns.

Calc: Droop = $\frac{E_D}{E_{OUT}}$ x 100%. (see Figure 1 for E_D)

FIGURE 3. CIRCUIT FOR WAVEFORM INTEGRITY

TABLE 1. GENERAL SPECIFICATIONS

PARAMETER	UNIT	VALUE	REMARKS
Case	—	—	Flame Resistant, Diallyl Phthalate
Terminals	—	—	C5191 Phosphor Bronze, Sn60Pb40 Plated, over Nickel Underplating
Terminals (Alternative)	—	—	C5191 Phosphor Bronze, Sn63Pb37 Dipped, over Matte SN100 Plating, over Nickel Underplating
Terminals (RoHS Version)	—	—	C5191 Phosphor Bronze, Matte Sn100 Plating, over Nickel Underplating
Weight	Oz (gm)	0.353 (10) max	—
Terminal Strength	lbs	2	2 pounds applied force, Method 211, MIL-STD-202, Test Condition A
Dielectric Withstanding Voltage	Vrms	100	Method 310, MIL-STD-202
Life (expectancy "X")	Hrs	10,000 min	In accordance with MIL-PRF-21038
Insulation Resistance	MΩ	1,000 min	At 250 Vdc using Method 302, Test Condition B, MIL-STD-202
Pulse Width (Output Pulse)	μs	2	Tested using FIGURE 3 with resulting FIGURE 1 waveform
Overshoot	V	± 1 max	Tested using FIGURE 3 with resulting FIGURE 1 waveform
Rise Time (Output Pulse)	ns	—	Tested using FIGURE 3 with resulting FIGURE 1 waveform See ELECTRICAL CHARACTERISTICS TABLE
Common Mode Rejection	dB	45	Tested using FIGURE 2
Operating Temperature Range	°C	-55 to +130	—
Droop	%	≤ 20	Tested using Figure 3 with resulting FIGURE 1 waveform
DC Resistance	Ω	—	See ELECTRICAL CHARACTERISTICS TABLE
Input Resistance	Ω	—	See ELECTRICAL CHARACTERISTICS TABLE

CONFIGURATION

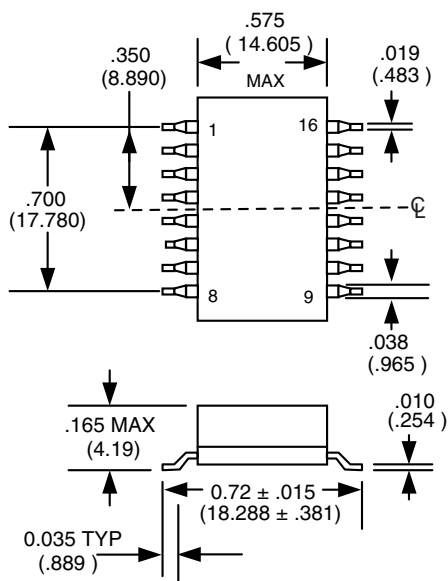

MECHANICAL OUTLINE

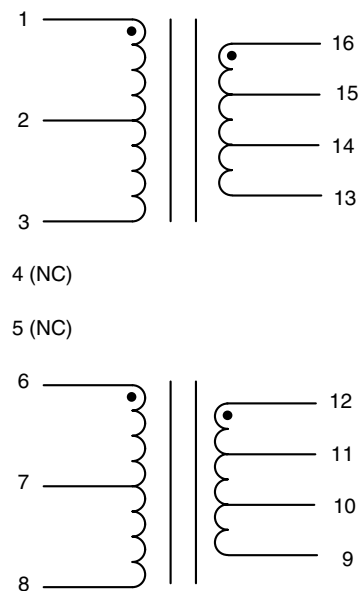
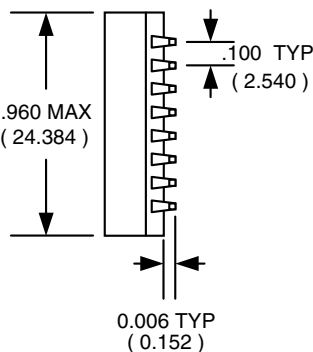

CIRCUIT DIAGRAM

Notes:

1. Dimensions are in inches (mm)
2. Tolerance, unless specified otherwise:
 - .xx is ± 0.010 inches (0.254)
 - .xxx is ± 0.005 inches (0.127)

TABLE 2. ELECTRICAL CHARACTERISTICS						
BETA P/N	PIN #S	TURNS RATIO ± 3%	DC RESISTANCE OHMS (MAX)	OUTPUT RISE TIME ns (MAX)	IMPEDANCE OHMS (MIN)	
					75 kHz to 150 kHz	150 kHz to 1 MHz
DSS-1003	1-3 (6-8) : 16-13 (12-9) 1-3 (6-8) : 15-14 (11-10)	1 : 3.75 1 : 2.7	(1-3), (6-8) 0.35 (16-13), (12-9) 3.0	250	(16-13), (12-9) 3,000	(16-13), (12-9) 4,000
DSS-1005	1-3 (6-8) : 16-13 (12-9) 1-3 (6-8) : 15-14 (11-10)	1 : 2.5 1 : 1.79	(1-3), (6-8) 1.0 (16-13), (12-9) 3.5	250	(16-13), (12-9) 3,000	(16-13), (12-9) 4,000
DSS-1012	1-3 (6-8) : 16-13 (12-9) 1-3 (6-8) : 15-14 (11-10)	1.25 : 1 1.66 : 1	(1-3), (6-8) 3.2 (16-13), (12-9) 3.0	150	(1-3), (6-8) 3,000	(1-3), (6-8) 4,000
DSS-1015	1-3 (6-8) : 16-13 (12-9) 1-3 (6-8) : 15-14 (11-10)	1.4 : 1 2 : 1	(1-3), (6-8) 3.5 (16-13), (12-9) 3.0	150	(1-3), (6-8) 5,000	(1-3), (6-8) 7,200
DSS-1630	1-3 (6-8) : 16-13 (12-9) 1-3 (6-8) : 15-14 (11-10)	1 : 2.65 1 : 2.07	(1-3), (6-8) 0.29 (16-13), (12-9) 1.10	250	(16-13), (12-9) 2,000	(16-13), (12-9) 4,000

RoHS Ordering Information: Add "-R" to standard part number (i.e. DSS-1003-R) (See note 3)

- Notes:**
1. These transformers have been classified as Level 3 rating per IPC-9503, and must be processed accordingly. To ensure product integrity and maintain product warranty, the customer must comply with the storage and handling conditions as specified in IPC-9503 for a level 3 device. Transformers must be reflowed within 168 hours of removal from sealed bag. Reflow process must not cause the peak body temperature of the device to exceed 225°C and must not expose the device to temperatures above 183°C for more than 90 seconds. These parts are provided dry-packed in accordance with J-STD-033. Tape and Reel packaging is available. Contact factory for further information.
 2. By providing surface mount parts that have been dried per IPC-9503 (Moisture Sensitivity Classification for Non-IC components) and Dry-Packed in accordance with J-STD-033 (Standard for handling, packing, shipping and use of Moisture/Reflow sensitive surface mount devices), Beta has significantly reduced the possibility of moisture sensitivity/reflow induced "Pop-corning" or Bulging during customer's reflow soldering process. Experiments performed by Beta and data provided by manufacturers of similar devices indicate that post reflow visual/mechanical anomalies can be reduced by more than 90%. Since customer reflow profiles and CCA density can vary, Beta recommends that the customer verify solder process compatibility and yield assessment of these devices.
 3. The Lead-Free/RoHS compliant versions use Sn10Pb88Ag02 for internal solder joints. High melting temperature solder in excess of 85% lead is exempt until a suitable alternative is available. The external lead finish is matte-tin with a nickel barrier layer that has been certified to pass JESD22A121.01 tin whisker limits. The magnet wire used has a minimum Thermo-plastic Flow rating of 250°C. These transformers are classified as IPC-9503 level 5A. The peak body temperature shall not exceed 245°C, and the time over 183°C shall not exceed 150 seconds. The Lead-Free/RoHS compliant part numbers are the standard part, with an "-R" as the part number suffix. The bottom of the header has the Pb-free symbol embossed on it.

TAPE AND REEL MECHANICAL OUTLINE

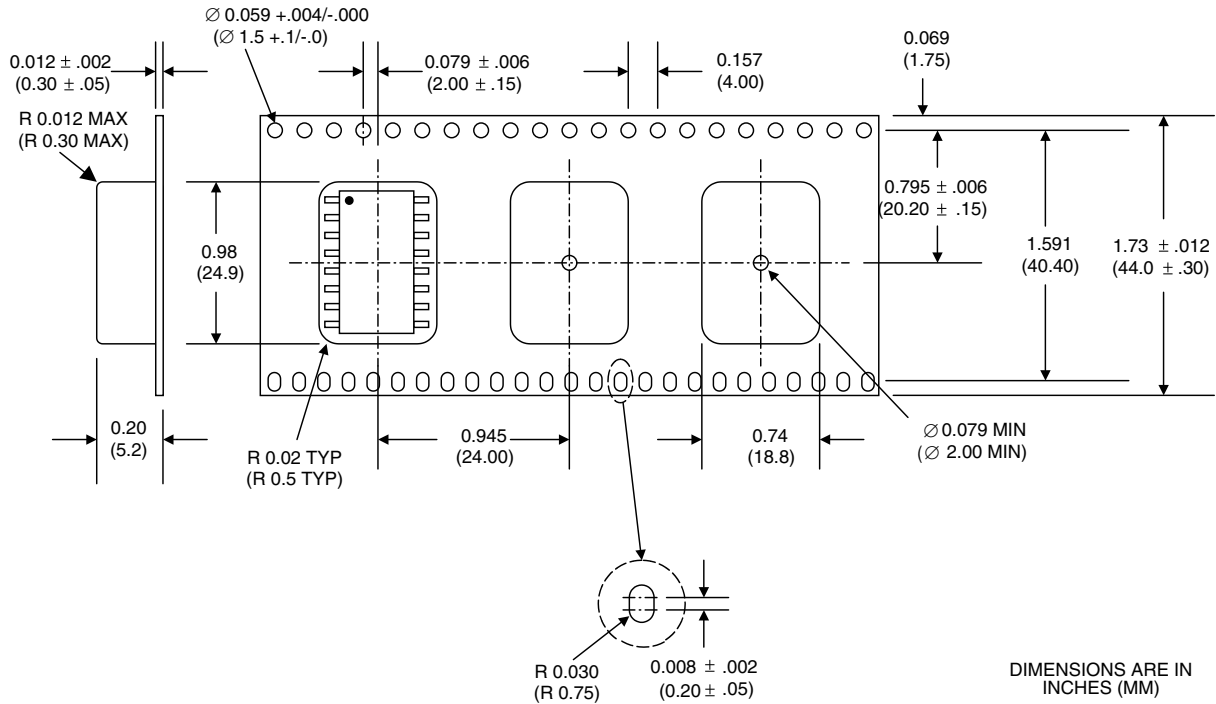

TOLERANCES
 .XX (.X) = ± .008 (0.20)
 .XXX (.XX) = ± .004 (0.10)

PARTS PACKAGED ON 13" DIAMETER REEL,
 450 PARTS PER FULL REEL.

The information in this data sheet is believed to be accurate; however, no responsibility is assumed by Beta Transformer Technology Corporation for its use, and no license or rights are granted by implication or otherwise in connection therewith. Specifications are subject to change without notice.

Visit our Web site at www.bttc-beta.com for the latest information.



**BETA TRANSFORMER
TECHNOLOGY CORPORATION**

A Subsidiary of Data Device Corporation

40 Orville Drive, Bohemia, NY 11716-2529

Headquarters, N.Y., U.S.A. - Tel: (631) 244-7393; Fax: (631) 244-8893

United Kingdom - Tel: +44-(0)1635-811140, Fax: +44-(0)1635-32264

France - Tel: +33-(0)1-41-16-3424, Fax: +33-(0)1-41-16-3425

Germany - Tel: +49-(0)89-15 00 12-11, Fax: +49-(0)89-15 00 12-22

Japan - Tel: +81-(0)3-3814-7688, Fax: +81-(0)3-3814-7689

Asia - Tel: +65-6489-4801

World Wide Web - <http://www.bttc-beta.com>