

Low power compandor

NE/SA576

DESCRIPTION

The NE/SA576 is a unity gain level programmable compandor designed for low power applications. The NE576 is internally configured as an expander and a compressor to minimize external component count.

The NE576 can operate at 1.8V. During normal operations, the NE576 can operate from at least a 2V battery. If the battery voltage drops to 1.8V, this part will still continue to function, however, turning on the part at a V_{CC} of 1.8V requires two external resistors to bring V_{REF} to half V_{CC} . One resistor connects between V_{CC} and V_{REF} ; the other connects from V_{REF} to ground. A typical value for these external resistors is approximately 20k. A lower value can be used, but the power consumption will go up.

The NE576 is available in a 14-pin plastic DIP and SO packages.

FEATURES

- Operating voltage range 1.8V to 7V
- Low power consumption (1.4mA @ 3.6V)
- Over 80dB of dynamic range
- Wide input/output swing capability (rail-to-rail)
- Low external component count
- ESD hardened

APPLICATIONS

- Cordless telephone
- Consumer audio
- Wireless microphones
- Modems
- Electric organs
- Hearing aids
- Automatic level control

PIN CONFIGURATION

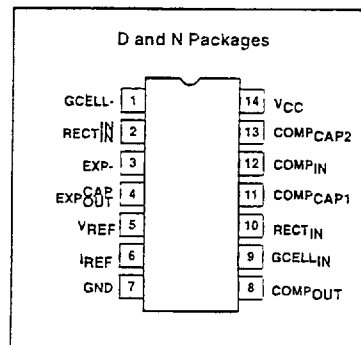

ORDERING INFORMATION

DESCRIPTION	TEMPERATURE RANGE	ORDER CODE	DWG #
14-Pin Plastic Dual In-Line Package (DIP)	0 to +70°C	NE576N	0405B
14-Pin Plastic Small Outline (SO)	0 to +70°C	NE576D	0175D
14-Pin Plastic Dual In-Line Package (DIP)	-40 to +85°C	SA576N	0405B
14-Pin Plastic Small Outline (SO)	-40 to +85°C	SA576D	0175D

ABSOLUTE MAXIMUM RATINGS

SYMBOL	PARAMETER	RATING		UNITS	
		NE576	SA576		
V_{CC}	Supply voltage	8	8	V	
T_A	Operating ambient temperature range	0 to +70	-40 to +85	°C	
T_{STG}	Storage temperature range	-65 to +150	-65 to +150	°C	
θ_{JA}	Thermal impedance	DIP	90	90	°C/W
		SO	125	125	°C/W

Low power compandor

NE/SA576

BLOCK DIAGRAM and TEST AND APPLICATION CIRCUIT

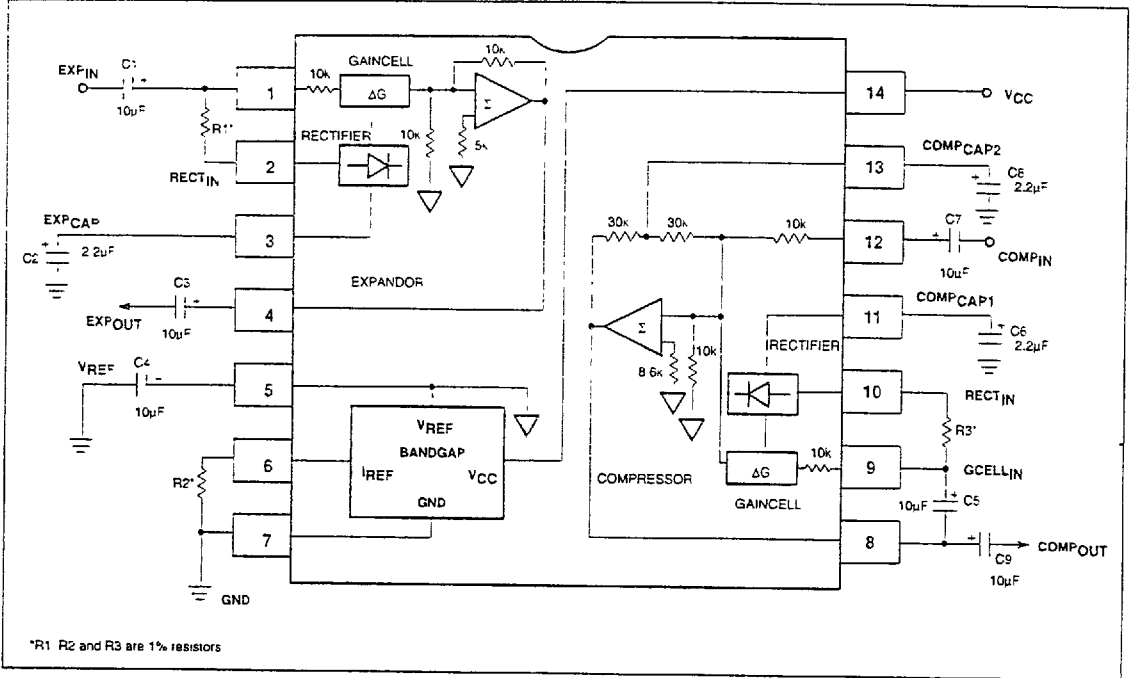

ELECTRICAL CHARACTERISTICS

T_A = 25°C, V_{CC} = 3.6VDC, compandor 0dB level = -20dBV = 100mV_{RMS}, output load R_L = 10kΩ, Freq = 1kHz, unless otherwise specified
 R1, R2 and R3 are 1% resistors

SYMBOL	PARAMETER	TEST CONDITIONS	LIMITS			UNITS
			NE/SA576			
			MIN	TYP	MAX	
V _{CC}	Supply voltage ¹		2	3.6	7	V
I _{CC}	Supply current	No signal R ₂ = 100kΩ		1.4	3	mA
V _{REF}	Reference voltage ²	V _{CC} = 3.6V		1.8		V
R _L	Summing amp output load		10			kΩ
THD	Total harmonic distortion	1kHz, 0dB, BW = 3.5kHz		0.25	1.5	%
E _{NO}	Expander output noise voltage	BW = 20kHz, F _S = 0Ω		10	30	μV
0dB	Unity gain level	0dB at 1kHz	-1.5	0.18	1.5	dB
V _{OS}	Output voltage offset	No signal	-150	1	150	mV
	Expander output DC shift	No signal to 0dB	-100	7	100	mV
	Tracking error relative to 0dB output	-20dB expander	-1.0	0.3	1.0	dB
	Crosstalk, COMP to EXP	1kHz, 0dB, C _{REF} = 10uF		-80		dB
V _O	Output swing low			0.2		V
	Output swing high			V _{CC} - 0.2		V

NOTE:

1. Operation down to V_{CC} = 1.8V is possible, see description on front page of NE576 data sheet.
2. Reference voltage, V_{REF}, is typically at 1/2 V_{CC}

Low power compandor

NE/SA576

TYPICAL PERFORMANCE CHARACTERISTICS

$V_{CC} = 3.6V$, $T_A = 25^\circ C$, $R_1=R_3=7.15k\Omega$, $R_2=100k\Omega$, 0dB level = 100mV, $F_{rea} = 1kHz$

