

HN25084, HN25085

011352 011251

2048-word × 4-bit Programmable Read Only Memories

The HITACHI HN25084 and HN25085 are high speed electrically programmable, fully decoded TTL Bipolar 8192 bit read only memories organized as 2048 word by 4 bit with on-chip address decoding and one chip enable input. The HN25084 and HN25085 are fabricated with logic level "zeros" (low); logic level "ones" (high) can be electrically programmed in the selected bit locations. The same address inputs are used for both programming and reading.

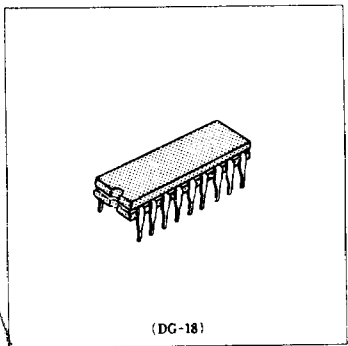

FEATURES

- 2048 word x 4 bit organization (fully decoded)
- DTL/TTL compatible inputs and outputs
- Fast read access time: 40 ns typ. (60 ns max)
- Medium power consumption: 550 mW typ.
- One chip enable input for memory expansion
- Open collector outputs (HN25084)/Three-state outputs (HN25085)
- Standard cerdip 18-pin dual in-line package

OPERATION

Programming

A logic one can be permanently programmed into a selected bit location by using programming equipment. First, the desired word is selected by the eleven address inputs in TTL level. The device is disabled by bringing \overline{CE} to a logic "one". Then a train of high current programming pulses is applied to the desired output. After the sensed voltage indicates that the selected bit is in the logic "one" state, an additional pulse train is applied, then is stopped.

Reading

To read the memory the device is enabled by bringing \overline{CE} to a logic "zero". The outputs then correspond to the data programmed in the selected word.

PIN ARRANGEMENT

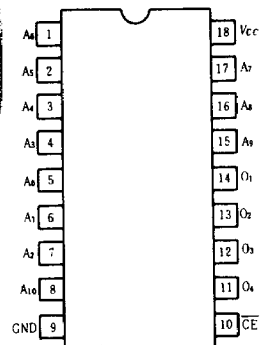

(Top View)

LOGIC DIAGRAM

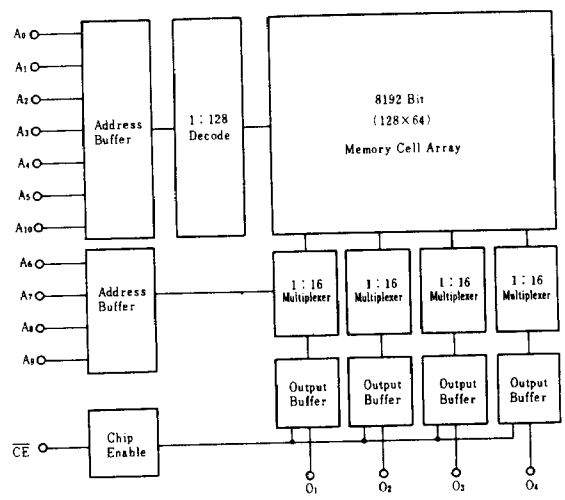

■ ABSOLUTE MAXIMUM RATINGS

Item	Symbol	Rating	Unit
Supply Voltage	V_{CC}	-0.5 to +7.0	V
Input Voltage	V_{in}	-0.5 to +5.5	V
Output Voltage	V_{out}	-0.5 to +5.5	V
Output Current	I_{out}	50	mA
Operating Temperature	T_{op}	-25 to +75	°C
Storage Temperature	T_{stg}	-65 to +150	°C

■ DC CHARACTERISTICS ($V_{CC}=4.75$ to $5.25V$, $T_a=0$ to $75^\circ C$)

Characteristic	Symbol	Test Conditions	min	typ	max	Unit
Input High Voltage	V_{IH}		2.0	—	—	V
Input Low Voltage	V_{IL}		—	—	0.8	V
Input High Current	I_{IH}	$V_I=2.7V$	—	—	40	μA
Input Low Current	$-I_{IL}$	$V_I=0.4V$	—	—	0.40	mA
Output Low Voltage	V_{OL}	$I_{OL}=16mA$	—	—	0.45	V
Output Leakage Current	I_{OLK1}	$V_O=5.25V$	—	—	100	μA
Output Leakage Current	I_{OLK2}	$V_O=0.4V$	—	—	40	μA
Input Clamp Voltage	V_I	$I_I=-18mA$	—	—	-1.2	V
Power Supply Current	I_{CC}	Inputs Either Open or at Ground	—	110	150	mA
Output High Voltage*	V_{OH}	$I_O=-2mA$	2.4	—	—	V
Output Short Circuit Current*	$-I_{OS}$	$V_O=0V$	15	—	60	mA

* Note: Applicable to HN25089 only.

■ AC CHARACTERISTICS ($V_{CC}=4.75$ to $5.25V$, $T_a=0$ to $75^\circ C$)

Characteristic	Symbol	Test Conditions	min	typ	max	Unit
Address Access Time	t_{AA}		—	40	60	ns
Chip Enable Access Time	t_{ACE}		—	20	35	ns
Chip Enable Disable Time	t_{DCE}		—	20	35	ns

Note) 1. Output Load: See Test Circuit.
 2. Measurement Reference: 1.5V for both inputs and outputs.

■ SWITCHING WAVEFORMS

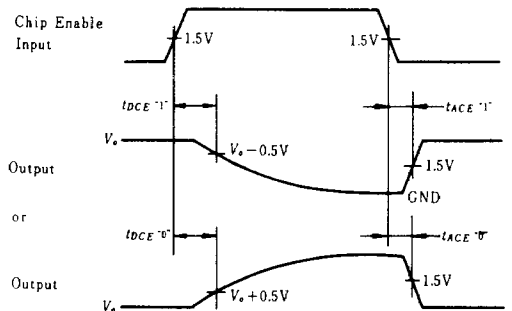
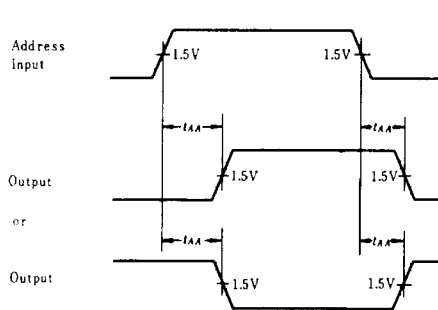

SWITCHING TIME TEST CONDITIONS

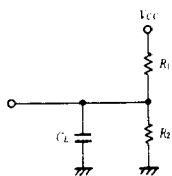

SWITCHING PARAMETER	HN25084			HN25085		
	R ₁	R ₂	C _L	R ₁	R ₂	C _L
t _{AA}	300Ω	600Ω	30pF	300Ω	600Ω	30pF
t _{ACE} "1"	—	—	—	∞	600Ω	10pF
t _{ACE} "0"	300Ω	600Ω	10pF	300Ω	600Ω	10pF
t _{DCE} "1"	—	—	—	∞	600Ω	30pF
t _{DCE} "0"	300Ω	600Ω	30pF	300Ω	600Ω	30pF

INPUT CONDITIONS
 Amplitude - 0V to 3V
 Rise and Fall time - 5ns from 1V to 2V
 Frequency - 1MHz

PROGRAMMING SPECIFICATION

Characteristic	Limit	Unit	Notes
Ambient Temperature	25 ± 5	°C	
Programming Pulse			
Amplitude	130 ± 5%	mA	
Clamp Voltage	20 ± 2%	V	
Ramp Rate	70max	V/μs	
Pulse Width	7.5 ± 5%	μs	10V point/150Ω load
Duty Cycle	70% min		
Sense Current			
Amplitude	20 ± 0.5	mA	
Clamp Voltage	20 ± 2%	V	
Ramp Rate	70max	V/μs	
Sense Current Interruption before and after address change	10min	μs	
Programming V _{CC}	5.0 + 5% - 0%	V	
Maximum Sensed Voltage for programmed "1"	7.5 ± 0.1	V	
Delay from trailing edge of programming pulse before sensing output voltage	0.7min	μs	
Programming Pulse Number	100max	ms	
Additional Programming Pulse Number	4	Time	

TYPICAL WAVEFORMS

