

DASH NO. M CODE MADE FROM

REVISIONS	
NO	CHANGES
0	ER 22253 GL 27 JUL 83
1	CN 29130 C AMD 17 AUG 87

KC-19-307-M06
 S-D
 (SHEET 1 OF 2)

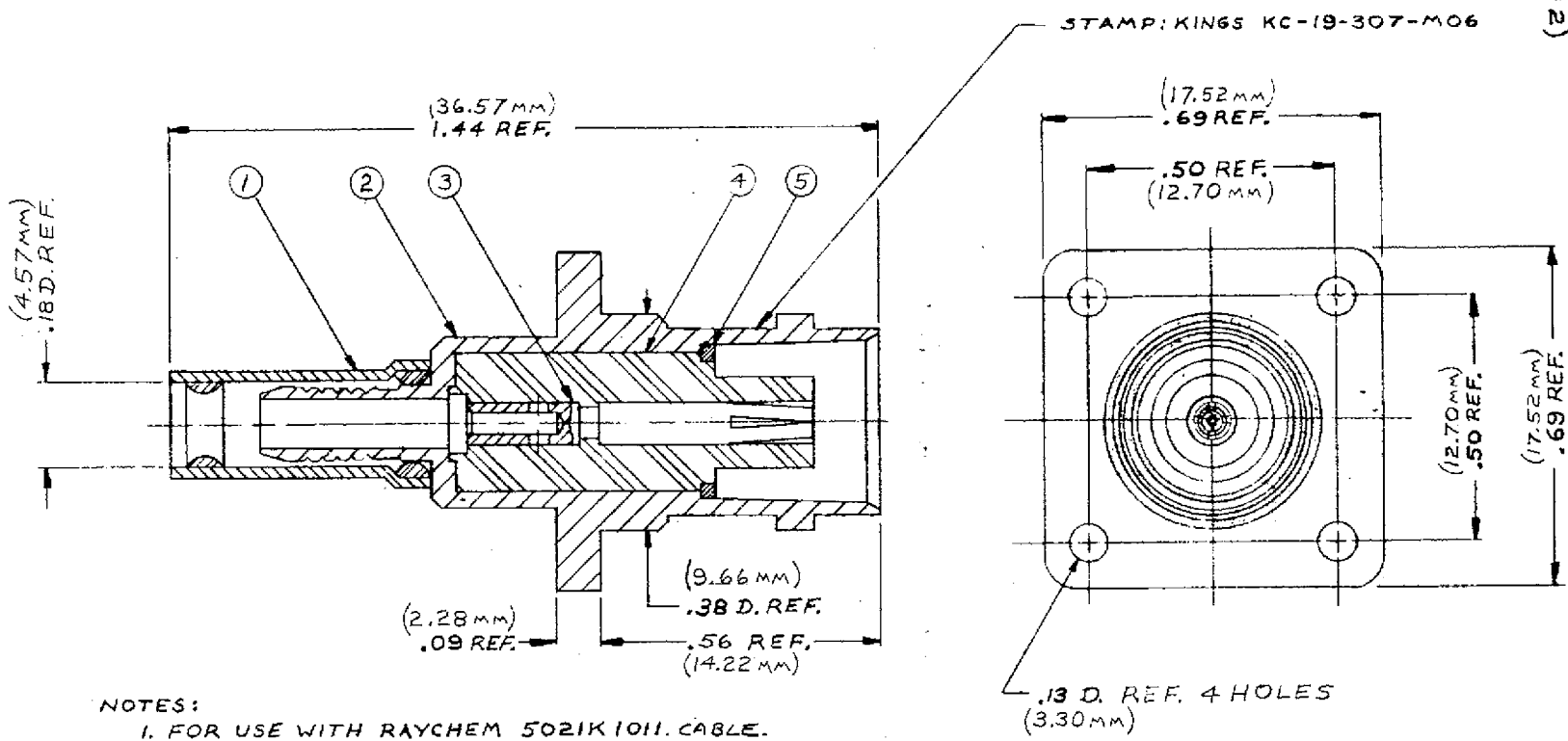

NOTES:

1. FOR USE WITH RAYCHEM 502IK1011 CABLE.
2. FOR CABLE TRIMMING USE KTJ-153 / KTD-161.
3. FOR CRIMPING USE DIE SIZE 128.
4. FOR CABLING INSTRUCTIONS SEE CP-5401.
5. ITEMS ①, ②, & ⑤ TO HAVE TR-5 FINISH.

UNLESS OTHERWISE SPECIFIED:

- | | |
|---|--|
| 1. TOLERANCES, FRACTIONS & 2 PLACE DECIMALS ± .010 | 2. REMOVE ALL BURRS, BREAK SHARP EDGES .005 MAX. |
| 3 PLACE DECIMALS ± .004 | 3. NO FILLETS PERMITTED. |
| ANGLES ± 0°30' | 4. SURFACE ROUGHNESS 83 MICROINCHES RMS MAX. |
| 7. I. R. CONCENTRICITY OF ANY 2 DIAMETERS MAY NOT EXCEED HALF THE SUM OF THEIR TOLERANCES | 5. ALL DIMENSIONS PRIOR TO PLATING. |
| | 6. ALL PLATING IN ACCORDANCE WITH KER 10004. |

MAX WEIGHT
15 GRAMS

SCALE	4:1
APPROX. SURFACE AREA	
USED ON	
REF	
BNC PANEL JACK	
DRAWN GL	DATE 15 JUL 81
APPN KLS	DATE 20 JUL 81

KC-19-307-M06

(SHEET 1 OF 2)