

SMD BALUN SERIES

ABT-3-XXX



FEATURES:

- SMT and Thru Hole available
- High Reliability
- Extended Temperature
- Lead Free

OPTIONS:

- Tape and Reel is standard
- Custom design available

APPLICATIONS:

- RF, Set Top Box, Cable Modem
- Cable TV, Wide Band RF Applicants
- Balance to Unbalance application
- RF signal monitor point

STANDARD SPECIFICATIONS:

Part No ABT-3-	Turns	Operating Frequency MHz	Insertion Loss dB Max	Figure
Double Balanced Mixer				
1A	1½	25-2000	3	A
2A	2½	6-2000	3	A
3A	3½	3.5-2000	3	A
4A	4½	2-2000	3	A
Frequency Mixer				
1B	1	8-750	3	B
2B	2	3.5-700	3	B
3B	3	2-800	3	B
Balun Transformer				
1C	1½	20-750	3	C
2C	2½	4.5-3000	3	C
3C	3½	2.3-2700	3	C
4C	4½	1.5-2400	3	C
Balun Transformer				
1D	1½	160-2000	3	D
2D	2½	55-1700	3	D
3D	3½	30-1400	3	D
Power Distributor/Combiners				
2E	-	20-600	in-out1,2 4.5dB max out1-out2, isolation 10dB	E
Directional Coupler				
2F	2½	6-600	in-out1, 2dB in-out2, 10dB	F
3F	3½	6-600	in-out1, 1.5dB in-out2, 11dB	F
4F	4½	6-600	in-out1, 1.3dB in-ou2t, 13dB	F
5F	5½	6-600	in-out1, 1.0dB in-out2, 15dB	F

OUTLINE DRAWING:

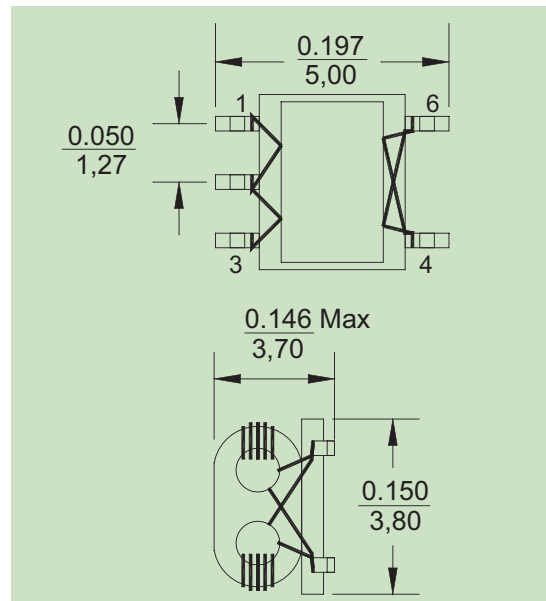
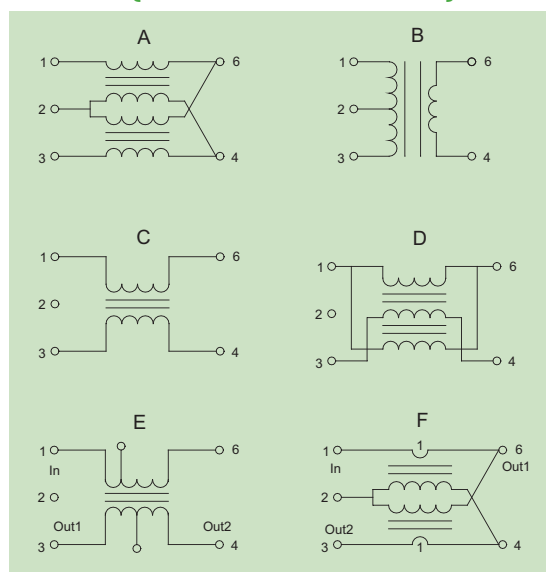

FIGURE (WIRE CONNECTION):



Dimensions: inch/mm

TECHNICAL INFORMATION:

- NO MARKING
- Add-T for tape and reel, -Z for lead free
- Operating temperature: -40°C to +85°C