

**QUAD TIMER**

The KA558B/I series are monolithic Quad Timers which can be used to produce four entirely independent timing functions. These highly stable, general purpose controllers can be used in a monostable mode to produce accurate time delays, from microseconds to hours. The time is precisely controlled by one external resistor and one capacitor in the time delay mode. A stable mode can be operated using two of four time sections.

**FEATURES**

- Wide Supply Voltage Range: 4.5V To 16V
- 100 mA Output Current Per Section
- Edge Triggered Without Coupling Capacitor
- Time Period Equals RC
- Output independent Of Trigger Conditions

**APPLICATIONS**

- Quad One-Shot
- Sequential Timing
- Precision Timing
- Time Delay Generation

**BLOCK DIAGRAM**

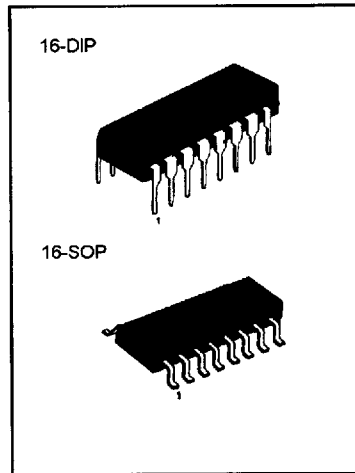
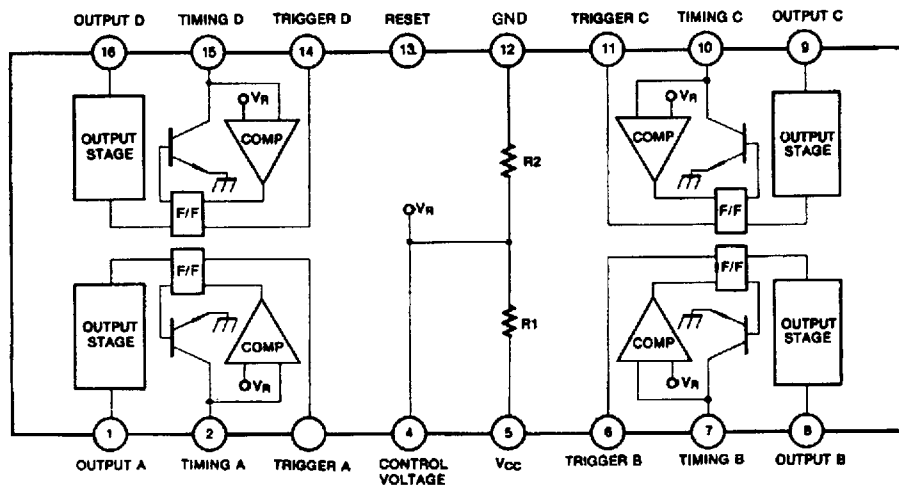

**ORDERING INFORMATION**

Device	Package	Operating Temperature
KA558B	16 DIP	0 ~ + 70°C
KA558BI	16 DIP	- 40 ~ + 85°C
KA558D	16 - SOP - 225	0 ~ + 70°C
KA558DI	16 - SOP - 300	0 ~ + 70°C

**ABSOLUTE MAXIMUM RATINGS (T<sub>A</sub> = 25°C)**

Characteristic	Symbol	Value	Unit
Supply Voltage	V <sub>CC</sub>	16	V
Lead Temperature (soldering 10sec)	T <sub>LEAD</sub>	300	°C
Power Dissipation	P <sub>D</sub>	600	mW
Operating Temperature Range KA558B	T <sub>OPR</sub>	0 ~ + 70	°C
KA558B/I		-40 ~ + 85	°C
Storage Temperature Range	T <sub>STG</sub>	-65 ~ + 150	°C

**ELECTRICAL CHARACTERISTICS**

(V<sub>CC</sub> = 5 ~ 15V, T<sub>A</sub> = 25°C, unless otherwise specified)

Characteristic	Symbol	Test Conditions	Min	Typ	Max	Unit
Supply Voltage	V <sub>CC</sub>		4.5		16	V
Supply Current	I <sub>CC</sub>	V <sub>CC</sub> = 15V, reset voltage = 15V		16	36	mA
Timing Error (T = RC)	ACCUR	R = 2KΩ to 100KΩ, C = 1 μF		± 2	5	%
Initial Accuracy						
Drift with Temperature			ΔV/ΔT		30	150
Drift with Supply Voltage	ΔV/ΔV <sub>CC</sub>			0.1	0.9	%/V
<sup>1</sup> Trigger Voltage	V <sub>TR</sub>	V <sub>CC</sub> = 15V		1.5	2.4	V
<sup>1</sup> Trigger Current	I <sub>TR</sub>	Trigger voltage = 0V		5.0	100	μA
<sup>2</sup> Reset Voltage	V <sub>RST</sub>	Reset	0.8	1.5	2.4	V
<sup>2</sup> Reset Current	I <sub>RST</sub>	Reset		50	500	μA
Threshold Voltage	V <sub>TH</sub>		0.8	0.63 × V <sub>CC</sub>		V
Threshold Current	I <sub>TH</sub>			15		nA
<sup>3</sup> Output Voltage	V <sub>O</sub>	I <sub>L</sub> = 10mA		0.1	0.4	V
		I <sub>L</sub> = 100mA		1.0	2.0	
Output Leakage Current	I <sub>LKG</sub>			10	500	nA
Propagation Delay Time	t <sub>D</sub>			1.0		μS
Rise Time	t <sub>R</sub>	I <sub>L</sub> = 100mA		100		nS
Fall Time	t <sub>F</sub>	I <sub>L</sub> = 100mA		100		nS

- NOTES: 1. The trigger functions only on the falling edge of the trigger pulse only after previously being high. After reset the trigger must be brought high and then low to implement triggering.  
 2. For reset below 0.8V, outputs set low and trigger inhibited.  
 3. Output structure is open collector which requires a pull up resistor to V<sub>CC</sub> to sink current. The output is normally low sinking current.

Dimensions in Millimeters

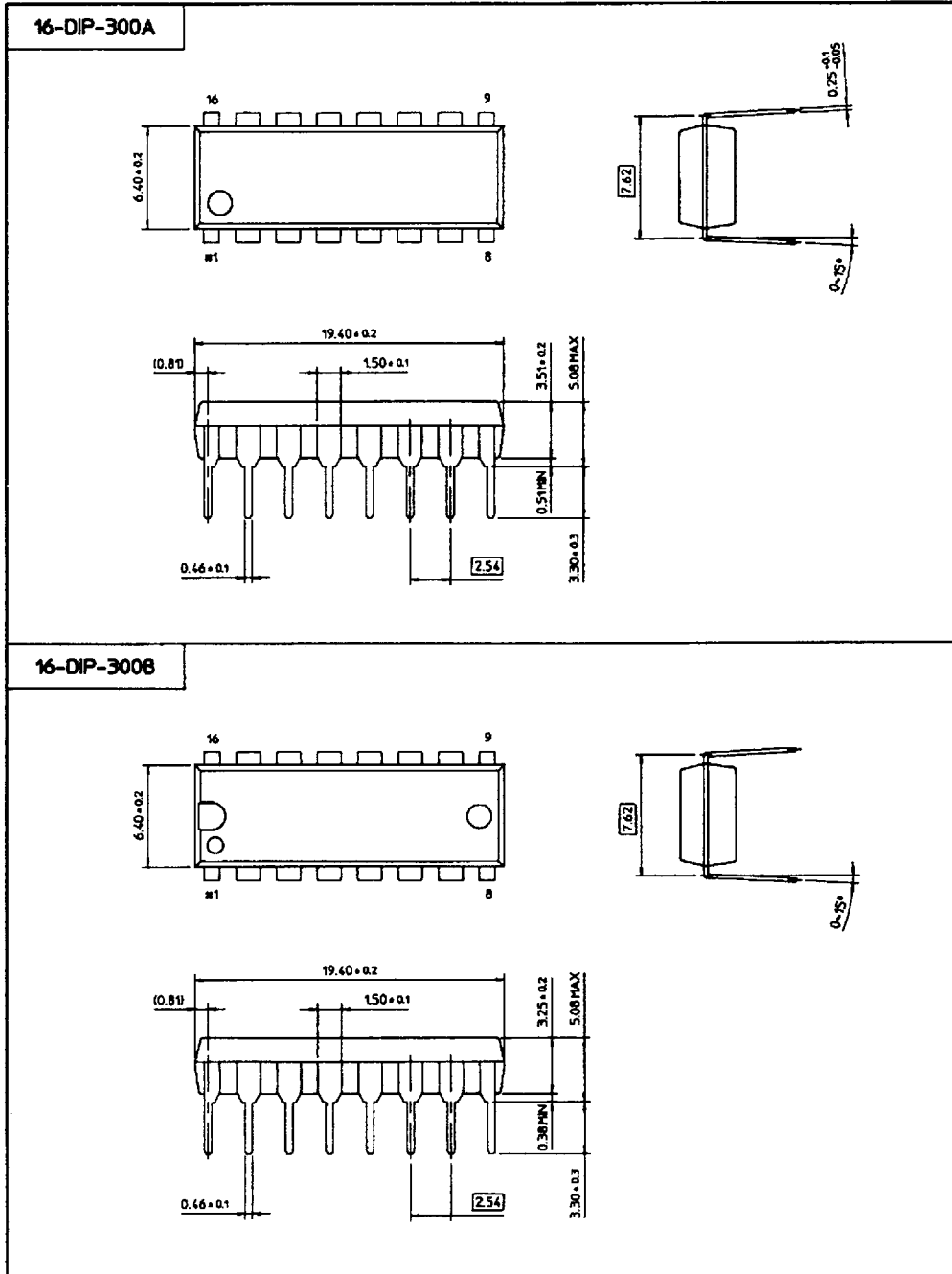

16-SOP-225

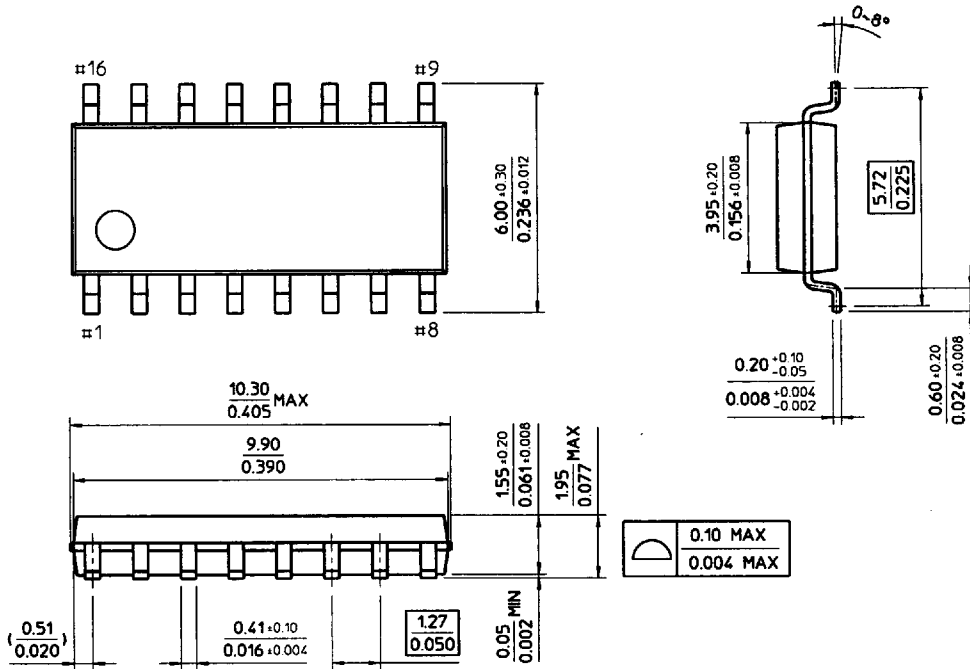

16-SOP-225A

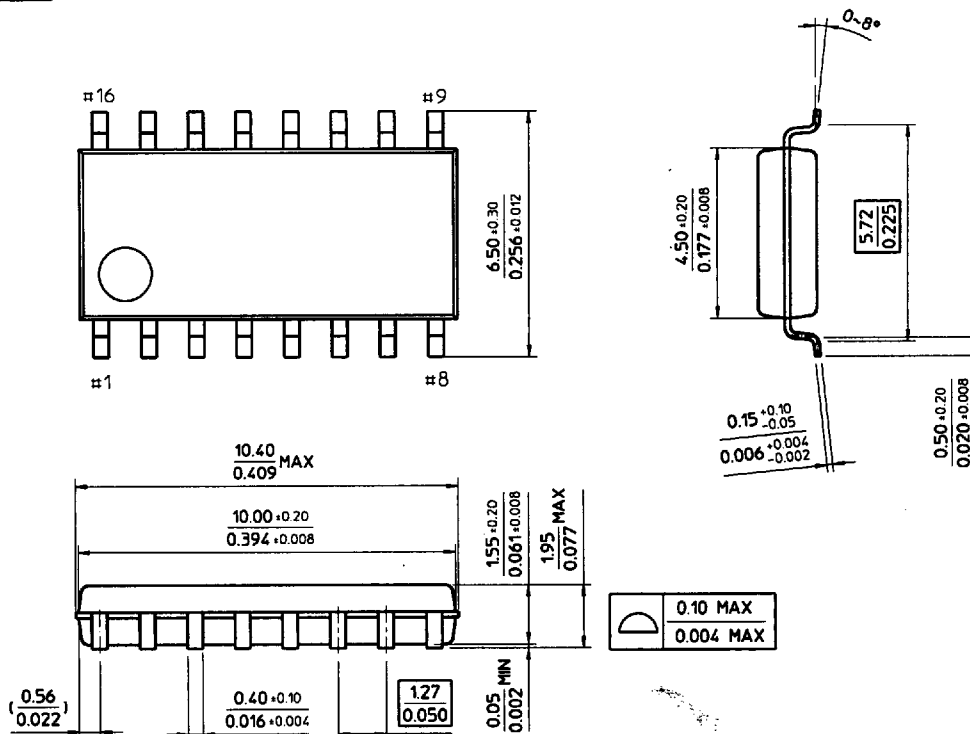

16-SOP-BD300-SG

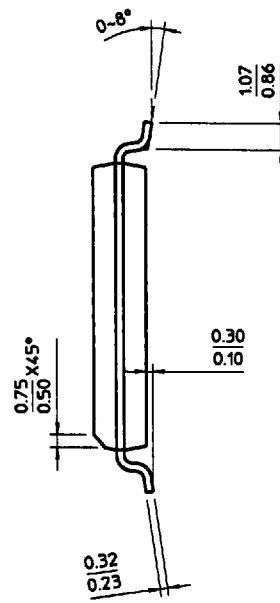
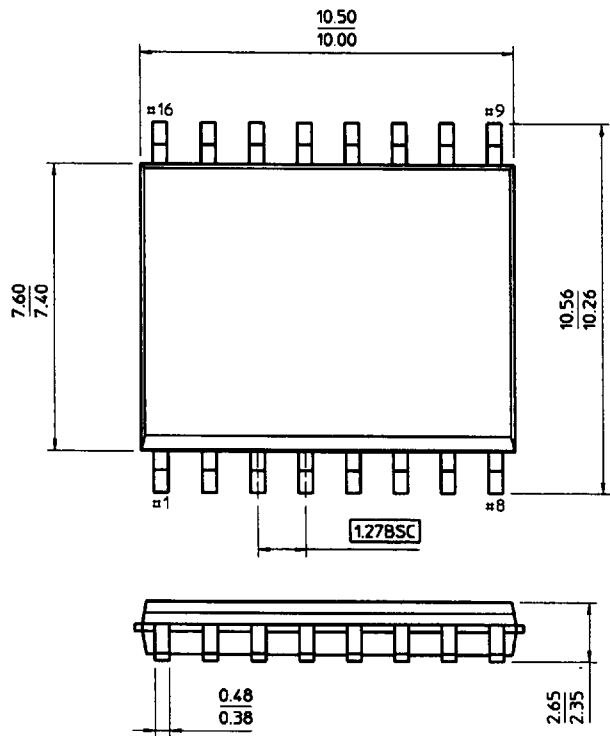

20-SOP-BD300-SG

