

SPECIFICATIONS:

1. CONTACT RESISTANCE : 20m OHM.
2. INSULATION RESISTANCE : DC 500V 100M OHM MIN.
3. VOLTAGE WITHSTANDING : AC 500V 1 MINUTE.
4. INSERTION FORCE : 6.5 KG MAX.
5. WITHDRAWAL FORCE : 1 - 5 KG.
6. LIFE TEST : 5,000 CYCLES MIN. AFTER TESTING , CONTACT RESISTANCE SHALL NOT EXCEED 100m OHM.
7. CURRENT RATING : AC : 100V 2A.
DC : 24V 1A.

DJ-S-08B-LF
LEADFREE
RoHS Compliant

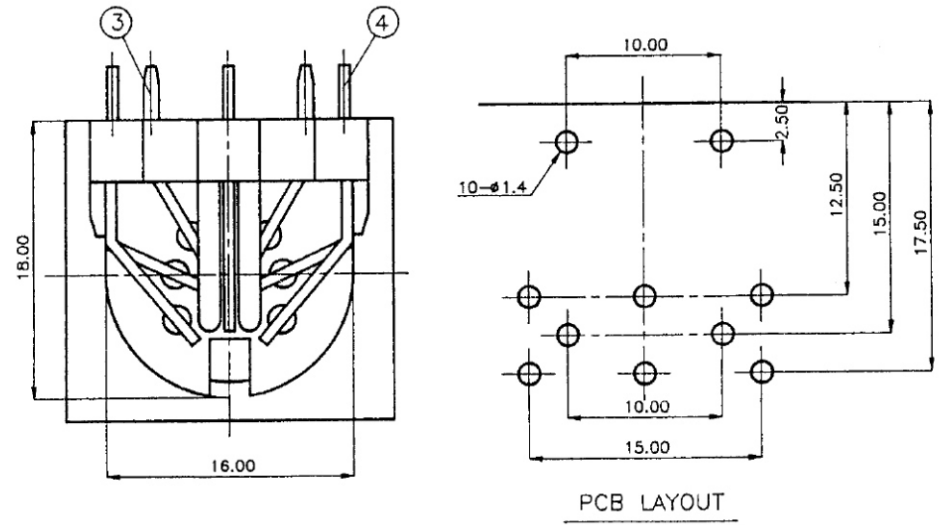

未指定尺寸公差為±0.2mm

4.	CONTACT TERMINAL	8	BSR-H/2 0.7t	TIN	
3.	EARTH TERMINAL	1	PBSR 0.25t	TIN	
2.	COVER	1	P.B.T.		UL94V-0
1.	BODY	1	P.B.T.		UL94V-0
P/N	PART NAME	Q'TY	MATERIAL	PLATING	REMARKS



PART NO. DJ-S-08B
DWG NO. DJ-S-08B
FILE NO.
UNIT / mm SCALE 1:1

CHECKED BY CY
DRAWING BY
PROJECTION

TOLERANCES ARE
.X ± 0.2
.XX ±
.XXX ±
AWG

DESCRIP TION:				
AREA	REVISIONS	HK	DATE	

焜倫股份有限公司