

SN100KT5538 OCTAL ECL-TO-TTL TRANSLATOR WITH OPEN-COLLECTOR OUTPUTS

D3493, APRIL 1990

- 100K Compatible
- Open-Collector Outputs Drive Bus Lines or Buffer Memory Address Registers
- ECL and TTL Control Inputs
- Flow-Through Architecture Optimizes PCB Layout
- Center-Pin V_{CC} , V_{EE} , and GND Configurations Minimize High-Speed Switching Noise
- Package Options Include "Small Outline" Packages and Standard Plastic 300-mil DIPs

DW OR NT PACKAGE
(TOP VIEW)

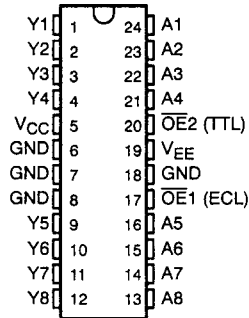

description

This octal ECL-to-TTL translator is designed to provide efficient translation between a 100K signal environment and a TTL signal environment. This device is designed specifically to improve the performance and density of ECL-to-TTL CPU/bus oriented functions such as memory address drivers, clock drivers, and bus-oriented receivers and transmitters while eliminating the need for three-state overlap protection.

Two output enables, $\overline{OE1}$ and $\overline{OE2}$, are provided. These enable inputs are ANDed together with $\overline{OE1}$ being ECL-compatible and $\overline{OE2}$ being TTL-compatible. This offers the choice of controlling the outputs of the device from either a TTL or ECL signal environment.

The SN100KT5538 is characterized for operation from 0°C to 85°C.

logic symbol†

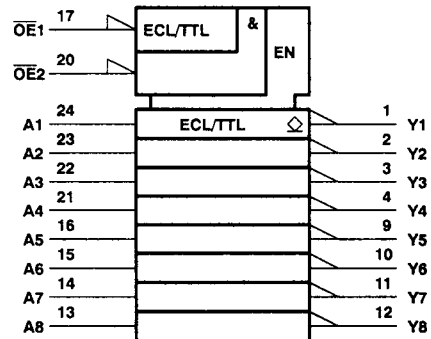

† This symbol is in accordance with ANSI/IEEE Std 91-1984 and IEC Publication 617-12.

FUNCTION TABLE

OUTPUT ENABLE		DATA INPUT	OUTPUT (TTL)	
$\overline{OE1}$	$\overline{OE2}$	A	X	Y
H	X	X	X	H
X	H	X	X	H
L	L	L	L	H
L	L	H	L	L

SN100KT538 OCTAL ECL-TO-TTL TRANSLATOR WITH OPEN-COLLECTOR OUTPUTS

D3493, APRIL 1990

logic diagram (positive logic)

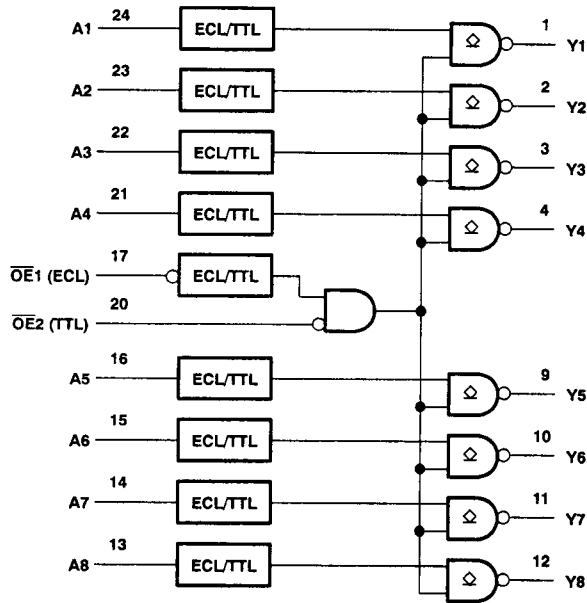

absolute maximum ratings over operating free-air temperature range (unless otherwise noted)[†]

Supply voltage range, V_{CC}	-0.5 V to 7 V
Supply voltage range, V_{EE}	-8 V to 0 V
Input voltage range (TTL) (see Note 1)	-1.2 V to 7 V
Input voltage range (ECL)	V_{EE} to 0 V
Input current range (TTL)	-30 mA to 5 mA
Current into any output in the low state	96 mA
Voltage applied to any output in the high state	-0.5 V to V_{CC}
Operating temperature range	0°C to 85°C
Storage temperature range	-65°C to 150°C

[†] Stresses beyond those listed under "absolute maximum ratings" may cause permanent damage to the device. These are stress ratings only and functional operation of the device at these or any other conditions beyond those indicated under "recommended operating conditions" is not implied. Exposure to absolute-maximum-rated conditions for extended periods may affect device reliability.

NOTE 1: The TTL input voltage ratings may be exceeded provided the input current ratings are observed.



POST OFFICE BOX 655303 • DALLAS, TEXAS 75265

SN100KT5538
OCTAL ECL-TO-TTL TRANSLATOR
WITH OPEN-COLLECTOR OUTPUTS

D3493, APRIL 1990

recommended operating conditions

		MIN	NOM	MAX	UNIT
V _{CC}	TTL supply voltage	4.5	5	5.5	V
V _{EE}	ECL supply voltage	-4.2	-4.5	-4.8	V
V _{IH}	High-level input voltage	TTL		2	V
		ECL (see Note 2)		-1150	-840
V _{IL}	Low-level input voltage	TTL		0.8	V
		ECL (see Note 2)		-1810	-1490
V _{OH}	TTL high-level output voltage		5.5	V	
I _{OL}	TTL low-level output current		48	mA	
I _{IK}	TTL input clamp current		-18	mA	
T _A	Operating free-air temperature	0	85	°C	

NOTE 2: The algebraic convention, in which the least positive (most negative) value is designated minimum, is used in this data sheet for logic levels only.

electrical characteristics over recommended operating free-air temperature range (unless otherwise noted)

PARAMETER		TEST CONDITIONS			MIN	TYP†	MAX	UNIT
V _{IK}	OE2 only	V _{CC} = 4.5 V,	V _{EE} = -4.2 V,	I _I = -18 mA			-1.2	V
V _{OL}		V _{CC} = 4.5 V,	V _{EE} = -4.5 V ± 0.3 V,	I _{OL} = 48 mA	0.38		0.55	V
I _I	OE2 only	V _{CC} = 5.5 V,	V _{EE} = -4.8 V,	V _I = 7 V			0.1	mA
I _{IH}	OE2 only	V _{CC} = 5.5 V,	V _{EE} = -4.8 V,	V _I = 2.7 V			20	μA
	A inputs and OE1	V _{CC} = 5.5 V,	V _{EE} = -4.8 V,	V _I = -840 mV			350	
I _{IL}	OE2 only	V _{CC} = 5.5 V,	V _{EE} = -4.8 V,	V _I = 0.5 V			-0.5	mA
	A inputs and OE1	V _{CC} = 5.5 V,	V _{EE} = -4.8 V,	V _I = -1810 mV	0.5			
I _{OH}		V _{CC} = 4.5 V,	V _{EE} = -4.2 V,	V _{OH} = 5.5 V			250	μA
I _{CCH}		V _{CC} = 5.5 V,	V _{EE} = -4.8 V		66	95		mA
I _{CCL}		V _{CC} = 5.5 V,	V _{EE} = -4.8 V		79.5	114		mA
I _{EE}		V _{CC} = 5.5 V,	V _{EE} = -4.2 V		-23	-33		mA
C _i		V _{CC} = 5.5 V,	V _{EE} = -4.5 V		5			pF
C _o		V _{CC} = 5.5 V,	V _{EE} = -4.5 V		5			pF

switching characteristics over recommended ranges of supply voltage and operating free-air temperature (unless otherwise noted) (see Note 3)

PARAMETER	FROM (INPUT)	TO (OUTPUT)	C _L = 50 pF, R ₁ = 500 Ω, R ₂ = 500 Ω			UNIT
			MIN	TYP†	MAX	
t _{PLH}	Any A	Y	6.4	9.1	11.7	ns
t _{PHL}			2.7	4.9	7.2	
t _{PLH}	OE1 (ECL)	Y	7	10.1	13.3	ns
t _{PHL}			3.6	6.2	8.8	
t _{PLH}	OE2 (TTL)	Y	6.5	9.1	11.6	ns
t _{PHL}			2.8	5.3	7.9	

† All typical values are at V_{CC} = 5 V, V_{EE} = -4.5 V, T_A = 25°C.

NOTE 3: Load circuit and voltage waveforms are shown in Section 1.

