

■ General Description

The S-75V02ANC is a single 2-input NOR gate fabricated by utilizing advanced silicon-gate CMOS technology which provides the inherent benefit of CMOS low power consumption to achieve ultra high speed operation correspond to LSTTL IC's.

All gates of the internal circuitry have buffered outputs to ensure high noise immunity and output stability.

Input voltage is allowed to be applied even if power voltage is not supplied because no diode is inserted between an input pin and V_{CC} .

This allows for interfaces between power supplies of different voltage, output level conversion from 5 V to 3 V and battery backup applications.

■ Features

- Wide power supply range: 2 V to 5.5 V
- Low current consumption: 1.0 μ A max. (at 5.5 V, 25°C)
- Typical propagation delay: tpd = 3.6 ns (at 5 V)
- High noise immunity: $V_{NIH}=V_{NIL}=28\% V_{CC}$ min.
- Power down protection: All pins
- Very small plastic package: SC-88A

■ Applications

- Personal computers, peripherals
- Cellular phones
- Cameras
- Games

■ Pin Assignment

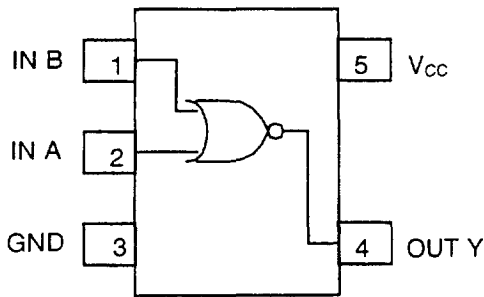

(Top view)

■ Marking

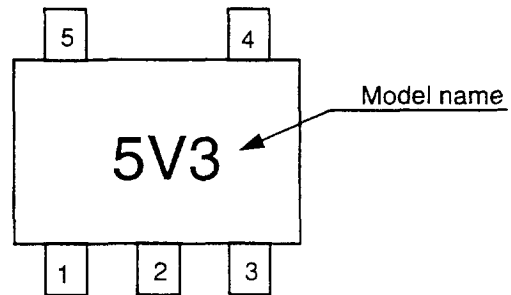

(Top view)

■ Logic Diagram

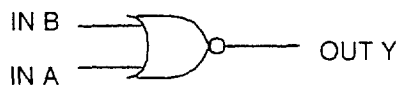

True Values

A	B	Y
L	L	H
L	H	L
H	L	L
H	H	L

■ Ordering

 Delivery form: Taping only
 Model name: S-75V02ANC-5V3-T2

■ Absolute Maximum Ratings

Ta=25°C

Item	Symbol	Ratings	Unit
Power Supply Voltage	V _{CC}	-0.5 to +7.0	V
Input Voltage	V _{IN}	-0.5 to +7.0	V
Output Voltage	V _{OUT}	-0.5 to V _{CC} +0.5	V
Input Parasitic Diode Current	I _{IK}	-20	mA
Output Parasitic Diode Current	I _{OK}	±20	mA
Output Current	I _{OUT}	±25	mA
V _{CC} /GND Current	I _{CC}	±50	mA
Power Dissipation	P _D	200	mW
Storage Temp. Range	T _{stg}	-65 to +150	°C
Lead Temperature (10 sec.)	TL	260	°C

■ Recommended Operating Conditions

Parameter	Symbol	Standard	Unit
Power Voltage	V _{CC}	2 to 5.5	V
Input Voltage	V _{IN}	0 to 5.5	V
Output Voltage	V _{OUT}	0 to V _{CC}	V
Op. Temp. Range	T _{opr}	-40 to +85	°C
Input Rise and Fall Time	dt/dv	0 to 100 (V _{CC} =3.3±0.3V)	ns/V
		0 to 20 (V _{CC} =5±0.5V)	

■ DC Characteristics

Parameter	Sym.	Conditions	Ta=25°C			Ta=-40 to 85°C		Unit				
			V _{CC}	MIN.	TYP.	MAX.	MIN.		MAX.			
Input Voltage	"H" level	V _{IH}	2.0	1.5	—	—	1.5	—	V			
			3 to 5.5	V _{CC} X0.7	—	—	V _{CC} X0.7	—				
	"L" level	V _{IL}	2.0	—	—	0.5	—	0.5				
			3 to 5.5	—	—	V _{CC} X0.3	—	V _{CC} X0.3				
Output Voltage	"H" level	V _{OH}	V _{IN} =V _{IL}	I _{OH} =-50μA	2.0	1.9	2.0	—	1.9	—	V	
					3.0	2.9	3.0	—	2.9	—		
					4.5	4.4	4.5	—	4.4	—		
					I _{OH} =-4mA	3.0	2.58	—	—	2.48		—
					I _{OH} =-8mA	4.5	3.94	—	—	3.80		—
					2.0	—	0	0.1	—	0.1		
	"L" level	V _{OL}	V _{IN} =V _{IH} or V _{IL}	I _{OL} =50μA	3.0	—	0	0.1	—	0.1		
					4.5	—	0	0.1	—	0.1		
					I _{OL} =4mA	3.0	—	—	0.36	—		0.44
					I _{OL} =8mA	4.5	—	—	0.36	—		0.44
Input Current	I _{IN}	V _{IN} =5.5V or GND	0 to 5.5	—	—	±0.1	—	±1.0	μA			
Current Consump.	I _{CC}	V _{IN} =V _{CC} or GND	5.5	—	—	1.0	—	10.0	μA			

■ **AC Characteristics**

Input $t_r = t_f = 3 \text{ ns}$ (unless otherwise specified)

Parameter	Sym.	Measurement Conditions		Ta=25°C			Ta=-40 to 85°C		Unit
		V _{CC} (V)	C _L (pF)	MIN.	TYP.	MAX.	MIN.	MAX.	
Output Rise/Fall time	t _{pLH}	3.3±0.3	15	—	5.6	7.9	1.0	9.5	ns
			50	—	10.0	14.0	1.0	15.0	
	5.0±0.5	15	—	3.6	5.5	1.0	6.5		
		50	—	5.7	8.0	1.0	9.0		
Input Capacitance	C _{IN}			—	4	10	—	10	pF
Equiv. Int. Capacitance	C _{PD}	Note ¹		—	15	—	—	—	pF

Note¹ C_{PD} is the no-load equivalent capacitance inside the circuitry. Refer to the measurement circuit shown below.

Current consumption is averaged by the following equation.

$$I_{CC(ave)} = C_{PD} \cdot V_{CC} \cdot f_{in} + I_{CC}$$

Measurement Circuit

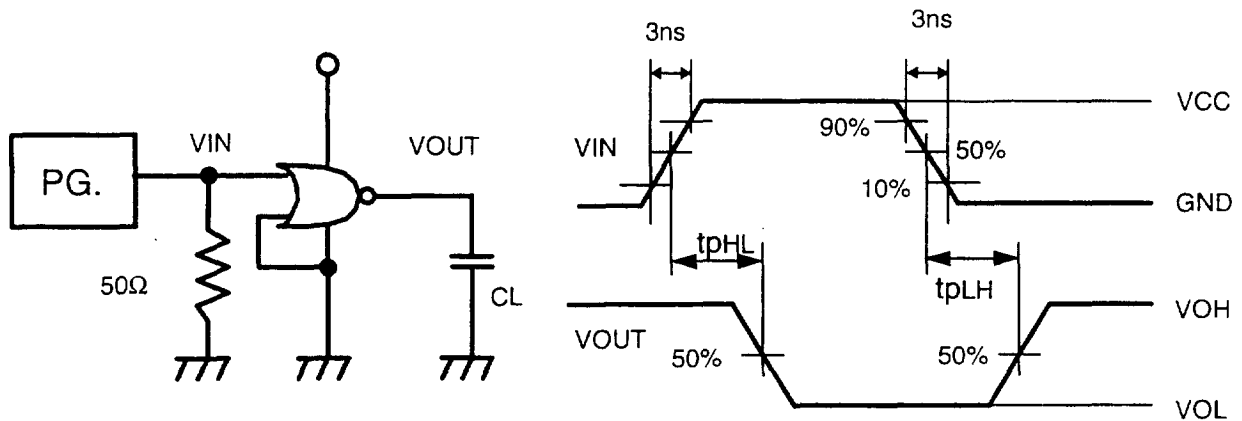

Remark: No-load output during measurement of current consumption.

■ **Input Pin Equivalent Circuit**

