

Silizium-Fotoelement Silicon Photovoltaic Cell

BPY 11 P

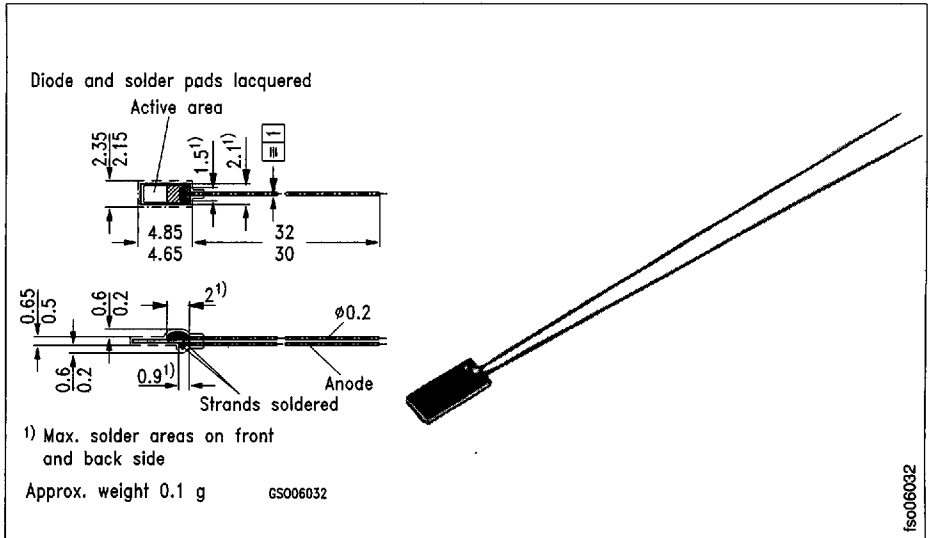

Maße in mm, wenn nicht anders angegeben/Dimensions in mm, unless otherwise specified.

Wesentliche Merkmale

- Speziell geeignet für Anwendungen im Bereich von 420 nm bis 1060 nm
- Kathode = Chipunterseite
- Mit feuchtigkeitsabweisender Schutzschicht überzogen

Anwendungen

- für Meß-, Steuer- und Regelzwecke
- zur Abtastung von Lichtimpulsen
- quantitative Lichtmessung im sichtbaren Licht- und nahen Infrarotbereich

Features

- Especially suitable for applications from 420 nm to 1060 nm
- Cathode = back contact
- Coated with a humidity-proof protective layer

Applications

- For control and drive circuits
- Light pulse scanning
- Quantitative light measurements in the visible light and near infrared range

Typ Type	Bestellnummer Ordering Code
BPY 11 P V	Q60215-Y111-S5

■ 8235605 0088203 558 ■

Grenzwerte
Maximum Ratings

Bezeichnung Description	Symbol Symbol	Wert Value	Einheit Unit
Betriebs- und Lagertemperatur Operating and storage temperature range	$T_{op}; T_{stg}$	- 55 ... + 100	°C
Sperrspannung Reverse voltage	V_R	1	V

Kennwerte ($T_A = 25\text{ °C}$, Normlicht A, $T = 2856\text{ K}$)

Characteristics ($T_A = 25\text{ °C}$, standard light A, $T = 2856\text{ K}$)

Bezeichnung Description	Symbol Symbol	Wert Value	Einheit Unit
Fotoempfindlichkeit, $V_R = 0\text{ V}$ Spectral sensitivity	S	60 (≥ 56)	nA/lx
Wellenlänge der max. Fotoempfindlichkeit Wavelength of max. sensitivity	$\lambda_{S\max}$	850	nm
Spektraler Bereich der Fotoempfindlichkeit $S = 10\%$ von S_{\max} Spectral range of sensitivity $S = 10\%$ of S_{\max}	λ	420 ... 1060	nm
Bestrahlungsempfindliche Fläche Radiant sensitive area	A	7.6	mm ²
Abmessungen der bestrahlungsempfindlichen Fläche Dimensions of radiant sensitive area	$L \times B$ $L \times W$	1.95 × 4.45	mm × mm
Halbwinkel Half angle	φ	± 60	Grad deg.
Dunkelstrom, $V_R = 1\text{ V}; E = 0$ Dark current	I_R	1 (≤ 10)	µA
Spektrale Fotoempfindlichkeit, $\lambda = 850\text{ nm}$ Spectral sensitivity	S_λ	0.55	A/W
Quantenausbeute, $\lambda = 850\text{ nm}$ Quantum yield	η	0.80	Electrons Photon
Leerlaufspannung, $E_v = 1000\text{ lx}$ Open-circuit voltage	V_O	440 (≥ 260)	mV
Kurzschlußstrom, $E_v = 1000\text{ lx}$ Short-circuit current	I_{SC}	60 (≥ 47)	µA

Kennwerte ($T_A = 25\text{ °C}$, Normlicht A, $T = 2856\text{ K}$)

Characteristics ($T_A = 25\text{ °C}$, standard light A, $T = 2856\text{ K}$)

Bezeichnung Description	Symbol Symbol	Wert Value	Einheit Unit
Anstiegs- und Abfallzeit des Fotostromes Rise and fall time of the photocurrent $R_L = 1\text{ k}\Omega$; $V_R = 1\text{ V}$; $\lambda = 850\text{ nm}$; $I_p = 50\text{ }\mu\text{A}$	t_r, t_f	3	μs
Temperaturkoeffizient von V_O Temperature coefficient of V_O	TC_V	-2.6	mV/K
Temperaturkoeffizient von I_{SC} Temperature coefficient of I_{SC}	TC_I	0.12	%/K
Kapazität, $V_R = 1\text{ V}$, $f = 1\text{ MHz}$, $E = 0$ Capacitance	C_0	0.8	nF

Fotoempfindlichkeitsgruppen Spectral sensitivity groups

Typ Type	$I_{SC} (E_v = 1000\text{ lx})$
BPY 11 P V	$\geq 56\text{ }\mu\text{A}$

Relative spectral sensitivity
 $S_{rel} = f(\lambda)$

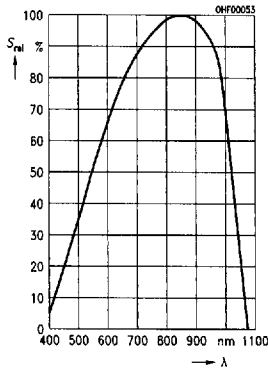

Open-circuit voltage $V_O = f(E_V)$
Short-circuit current $I_{SC} = f(E_V)$

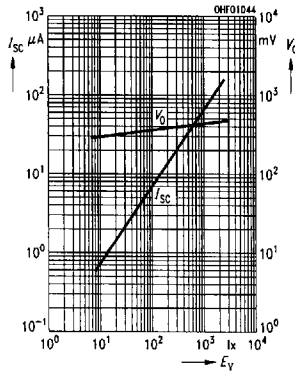

Capacitance
 $C = f(V_R), f = 1 \text{ MHz}, E = 0$

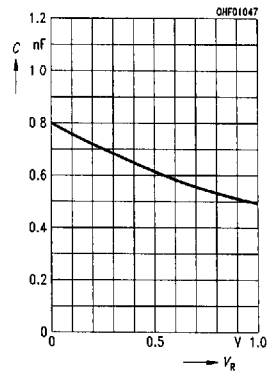

Dark current
 $I_R = f(T_A), V_R = 1 \text{ V}, E = 0$

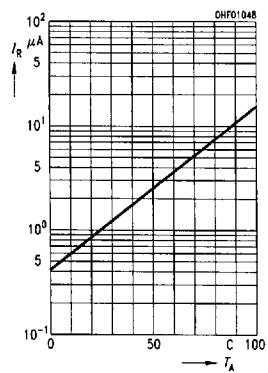

Dark current
 $I_R = f(V_R), E = 0$

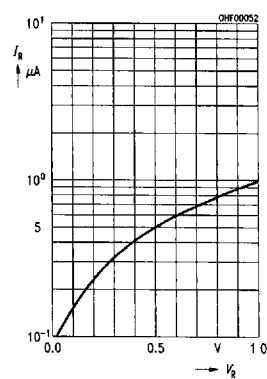

Directional characteristics $S_{rel} = f(\varphi)$

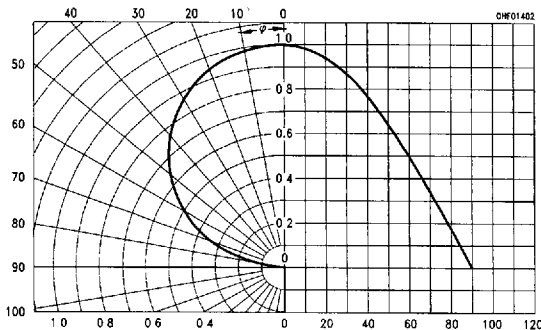

8235605 0088206 267