

LINEAR BUILDING BLOCK – QUAD LOW-POWER COMPARATOR AND VOLTAGE REFERENCE

FEATURES

- Combines Four Comparators and a Voltage Reference in a Single Package
- Optimized for Single-Supply Operation
- Small Package 16-Pin SOIC, QSOP, or DIP (Narrow) 16-Pin SOIC, QSOP, or DIP (Narrow)
- Ultra Low Input Bias Current Less than 100 pA
- Low Quiescent Current 18 μ A, Max
- Rail-to-Rail Inputs and Outputs
- Operates Down to $V_{DD} = 1.8V$, Min

APPLICATIONS

- Power Management Circuits
- Battery Operated Equipment
- Consumer Products

FUNCTIONAL BLOCK DIAGRAM

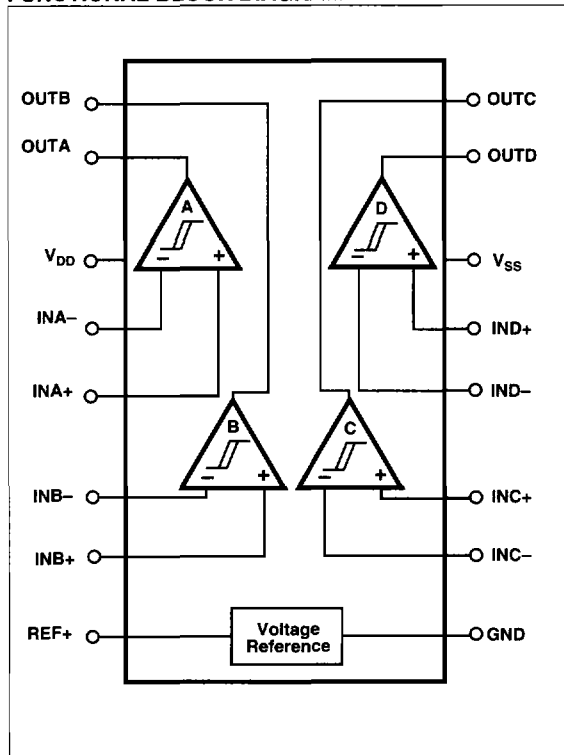

GENERAL DESCRIPTION

The TC1027 is a mixed-function device combining four general purpose comparators (complementary or open drain outputs) and a voltage reference in a single 16-pin package.

This increased integration allows the user to replace two packages, which saves space, lowers supply current, and increases system performance.

The TC1027 is designed specifically for operation from a single supply, however, operation from dual supplies also is possible. The power supply current drain is independent of the magnitude of the power supply voltage. The TC1027 is optimized for low supply voltage and very low supply current operation (18 μ A max), making it ideal for battery-operated applications.

Packaged in a 16-pin QSOP, SOIC (0.150 wide) or 16-pin DIP, the TC1027 is ideal for applications requiring high integration, small size, and low power.

3

PIN CONFIGURATIONS (DIP, QSOP, and SOIC)

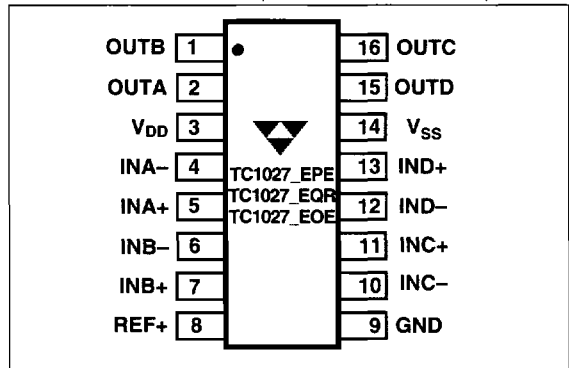

ORDERING INFORMATION

Part No.	Package	Comparator Outputs	Temp. Range
TC1027NEPE	16-Pin DIP	Open Drain	-40°C to +85°C
TC1027NEQR	16-Pin QSOP	Open Drain	-40°C to +85°C
TC1027NEOE	16-Pin SOIC	Open Drain	-40°C to +85°C
TC1027CEPE	16-Pin DIP	Complementary	-40°C to +85°C
TC1027CEQR	16-Pin QSOP	Complementary	-40°C to +85°C
TC1027CEOE	16-Pin SOIC	Complementary	-40°C to +85°C

TC1043EV Evaluation Kit for Linear Building Block Family