

Features

- Complete UHF ASK transmitter
- Frequency range 300MHz to 450MHz
- Data rates higher than 10kbps
- Output Power up to 10dBm
- Low voltage operation - down to 2.0V
- Data tracking function for device wake-up
- Reference clock output
- 8-pin SOP packages

Applications

- Car alarm Remote control
- Wireless PIR
- Remote Power Switches
- Multi-Media Remote Control
- Remote Sensor Data Links
- Infrared Transmitter Replacement

General Description

The HT9831 is a highly integrated ASK transmitter IC for remote wireless applications in the 300 to 450MHz frequency band. This transmitter IC is a true "data-in, antenna-out" monolithic device making it very easy for users to implement a wireless system. It is only necessary to supply a crystal generated reference frequency, which is the RF carrier frequency divided by 32, and a few additional external parts to create a complete and versatile transmitter. The HT9831 is capable of delivering +9.5dBm into a 50Ω load. This power level is possible due to a small form factor transmitter (lossy antenna) which can operate near the maximum transmission regulation limit. The HT9831 utilises ASK/OOK - Amplitude Shift Keying/On-Off Keying- UHF receiver types from wide-band super-regenerative radios to narrow-band, high performance super-heterodyne receivers. The

HT9831 minimum ASK data rate is 10kbps which supports a more complicated control protocol.

To minimise power consumption, the HT9831 provides a data tracking function. In the Idle Mode, the internal PLL will be switched off, but when high to low data is received the PLL will be switched on and data will be transmitted without delay. The PLL will be turned off automatically and the HT9831 will return to the Idle Mode after no data input transients have been received for more than 300ms. As there is a reference clock output for the MCU, the MCU can use its internal RC clock rather than using an additional crystal for precise timing. With these combined features the HT9831 can provide a power-saving and cost effective solution for a huge range of remote wireless applications.

Block Diagram

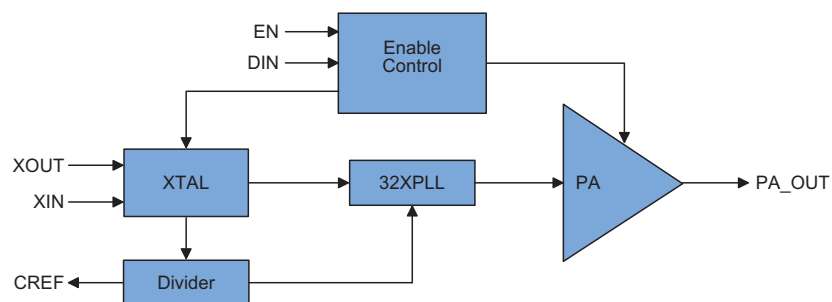

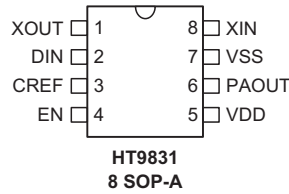
Pin Assignment

Pin Description

Pin No.	Pin Name	External Components	Description
1	XOUT	For 433.92MHz add 18pF capacitor For 315MHz add 15pF capacitor	Crystal Fs output
2	DIN		ASK data input
3	CREF	Output clock (Fs/65536) to MCU I/O 433.92MHz: Typ 207Hz 315MHz: Typ 150Hz	
4	EN	Pull high resistor	High: RF always on Low: DIN high trigger RF on
5	VDD	10 μ F decoupling capacitor	Power supply
6	PA_OUT	L/C matched circuit	Power amplifier output
7	VSS		Ground
8	XIN	For 433.92MHz add 18pF capacitor For 315MHz add 15pF capacitor	Crystal Fs input

Absolute Maximum Ratings

Operating Supply Voltage	$V_{DD}=2.0V\sim 3.6V$
Voltage on I/O Pins	$V_{SS}-0.3$ to $V_{DD}+0.3V$
Storage Temperature Range	$-50^{\circ}C$ to $+125^{\circ}C$
Lead Temperature (soldering, 10 seconds).....	$+300^{\circ}C$
ESD HBM.....	$\pm 5KV$
ESD MM	$\pm 400V$
Ambient Operating Temperature (TA)	$-40^{\circ}C$ to $+85^{\circ}C$
Programmable Transmitter Frequency Ran.....	300MHz to 450MHz

Note: These are stress ratings only. Stresses exceeding the range specified under "Absolute Maximum Ratings" may cause substantial damage to the device. Functional operation of this device at other conditions beyond those listed in the specification is not implied and prolonged exposure to extreme conditions may affect device reliability.

Electrical Characteristics

Ta = 25°C, Freq REFOSC=13.560MHz, EN=VDD. Bold values indicate -40°C to +85°C unless otherwise noted. 1kbps data rate 50% duty cycle. RL 50Ω load (matched)

Symbol	Parameter	Test Conditions		Min.	Typ.	Max.	Unit
		V _{DD}	Conditions				
I _H	Data High Current	3V	@315MHz, POUT=+10dBm	—	13.5	—	mA
			@433.92MHz	—	13.5	—	mA
I _L	Data Low Current	3V	@315MHz	—	3.0	—	mA
			@433.92 MHz	—	3.0	—	mA
I _{STB}	EN Low & DIN Low Current	3V	@315MHz	—	1.0	—	μA
			@433.92 MHz	—	1.0	—	μA
RF and Crystal							
	Output power level	3.3V	@315MHz *	—	9.5	—	dBm
			@433.92MHz *	—	9.5	—	dBm
	Harmonics output for 315 MHz	3V	@630MHz, 2nd harm	—	-48	—	dBc
			@945MHz, 3rd harm	—	-60	—	dBc
	Harmonics output for 433.92MHz	3V	@867.84MHz, 2nd harm	—	-45	—	dBc
			@1301.76MHz, 3rd harm	—	-55	—	dBc
	Extinction ratio for ASK 10Kbps	3V	—	—	-70	—	dBc
	Data Rate	3V	—	—	50	—	kbps
	Occupied Bandwidth	3V	@315MHz	—	<900	—	kHz
			@433.92MHz	—	<1000	—	kHz
	315MHz Single Side Band Phase Noise	3V	100kHz from Carrier	—	-78	—	dBc/Hz
			1000kHz from Carrier	—	-77	—	dBc/Hz
	433.92MHz Single Side Band Phase Noise	3V	100kHz from Carrier	—	-78	—	dBc/Hz
			1000kHz from Carrier	—	-76	—	dBc/Hz
	XTLIN, XTLOUT	3V	Pin capacitance	—	2	—	pF
	External Capacitance	3V	See application circuit C3,C4 @315MHz	—	15	—	pF
			@433.92MHz	—	18	—	pF
	Output Blanking	3V	Standby transition from low to high **	—	500	—	μs
	ASK to RF Out Response Time	3V	Delta between ASK input transition from Low To High to RF output transition from low to high	—	1	—	μs
	CREF clock output frequency	3V	@315MHz	—	150	—	Hz
			@433.92MHz	—	207	—	Hz

Note: * Depend on PC board layout

** Generally limited by crystal

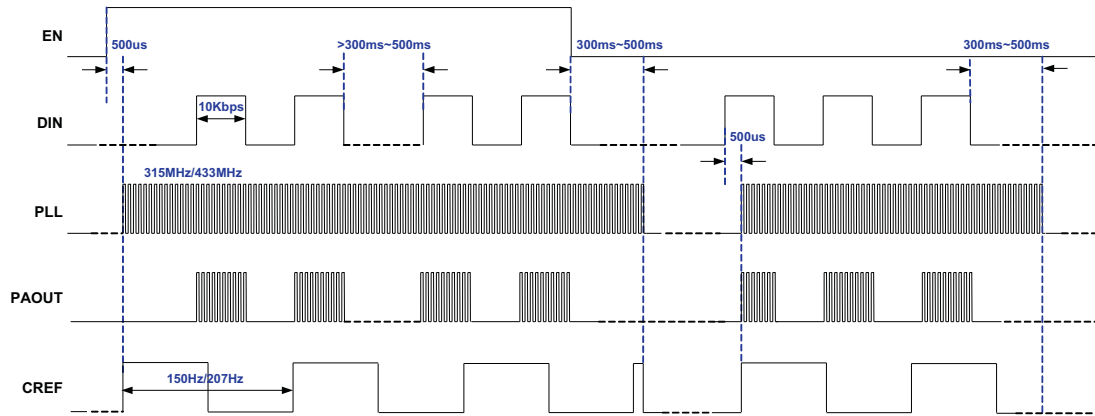
Timing Diagram

Note: CREF output clock frequency is much lower than PLL output frequency. The figure shown above is just for presentation.

State table:

EN	DIN	PAOUT	CREF
0	0	0	0
0	1	300~450MHz	143~215Hz
1	0	0	143~215Hz
1	1	300~450MHz	143~215Hz

Note: PAOUT output frequency is $f_{OSC} \times 32$ and CREF output clock frequency is $f_{OSC} / 2^{16}$. For example: PAOUT output frequency is $13.56\text{MHz} \times 32 = 433.92\text{MHz}$ and CREF output clock frequency is $13.56\text{MHz} / 2^{16} \approx 207\text{Hz}$.

Application Circuits – 315MHz (433MHz) TX

Test Circuits

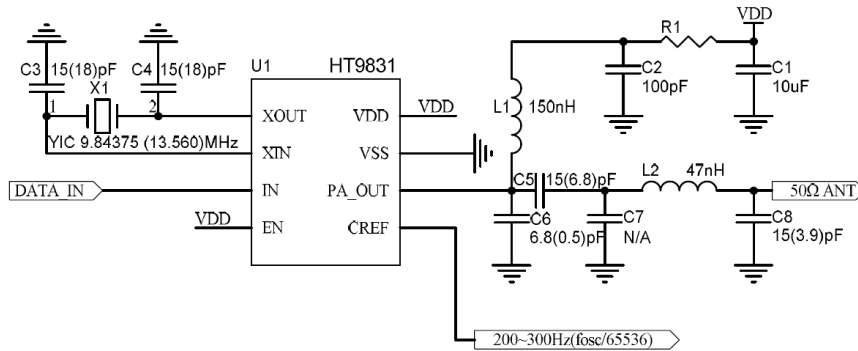

Low Cost Application Circuit

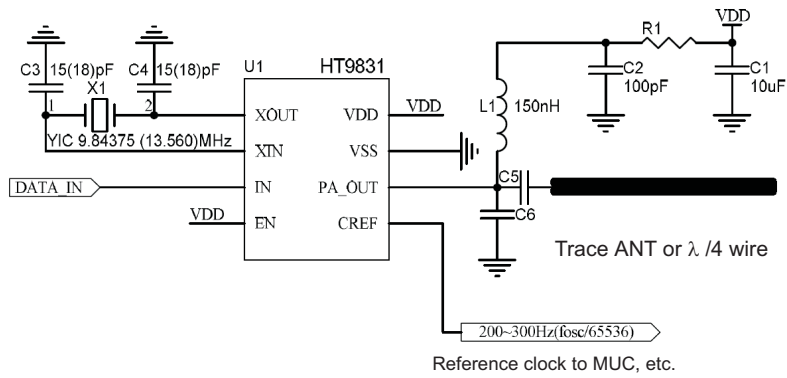

Package Information

Note that the package information provided here is for consultation purposes only. As this information may be updated at regular intervals users are reminded to consult the [Holtek website](#) for the latest version of the [Package/Carton Information](#).

Additional supplementary information with regard to packaging is listed below. Click on the relevant section to be transferred to the relevant website page.

- [Further Package Information \(include Outline Dimensions, Product Tape and Reel Specifications\)](#)
- [Packing Materials Information](#)
- [Carton Information](#)

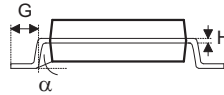
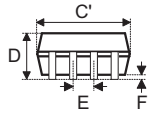
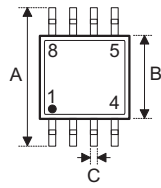
8-pin SOP (150mil) Outline Dimensions

Symbol	Dimensions in inch		
	Min.	Nom.	Max.
A	—	0.236 BSC	—
B	—	0.154 BSC	—
C	0.012	—	0.020
C'	—	0.193 BSC	—
D	—	—	0.069
E	—	0.050 BSC	—
F	0.004	—	0.010
G	0.016	—	0.050
H	0.004	—	0.010
α	0°	—	8°

Symbol	Dimensions in mm		
	Min.	Nom.	Max.
A	—	6.00 BSC	—
B	—	3.90 BSC	—
C	0.31	—	0.51
C'	—	4.90 BSC	—
D	—	—	1.75
E	—	1.27 BSC	—
F	0.10	—	0.25
G	0.40	—	1.27
H	0.10	—	0.25
α	0°	—	8°

Copyright © 2021 by HOLTEK SEMICONDUCTOR INC.

The information appearing in this Data Sheet is believed to be accurate at the time of publication. However, Holtek assumes no responsibility arising from the use of the specifications described. The applications mentioned herein are used solely for the purpose of illustration and Holtek makes no warranty or representation that such applications will be suitable without further modification, nor recommends the use of its products for application that may present a risk to human life due to malfunction or otherwise. Holtek's products are not authorized for use as critical components in life support devices or systems. Holtek reserves the right to alter its products without prior notification. For the most up-to-date information, please visit our web site at <http://www.holtek.com>.