

KFG4GH6x4M
KFH8GH6x4M
KFWAGH6x4M

4Gb Flex-OneNAND M-die

INFORMATION IN THIS DOCUMENT IS PROVIDED IN RELATION TO SAMSUNG PRODUCTS, AND IS SUBJECT TO CHANGE WITHOUT NOTICE.

NOTHING IN THIS DOCUMENT SHALL BE CONSTRUED AS GRANTING ANY LICENSE, EXPRESS OR IMPLIED, BY ESTOPPEL OR OTHERWISE,

TO ANY INTELLECTUAL PROPERTY RIGHTS IN SAMSUNG PRODUCTS OR TECHNOLOGY. ALL INFORMATION IN THIS DOCUMENT IS PROVIDED

ON AS "AS IS" BASIS WITHOUT GUARANTEE OR WARRANTY OF ANY KIND.

1. For updates or additional information about Samsung products, contact your nearest Samsung office.
2. Samsung products are not intended for use in life support, critical care, medical, safety equipment, or similar applications where Product failure could result in loss of life or personal or physical harm, or any military or defense application, or any governmental procurement to which special terms or provisions may apply.

Flex-OneNAND™, is a trademark of Samsung Electronics Company, Ltd. Other names and brands may be claimed as the property of their rightful owners.

* Samsung Electronics reserves the right to change products or specification without notice.

Revision History

Document Title

Flex-OneNAND

Revision History

<u>Revision No.</u>	<u>History</u>	<u>Draft Date</u>	<u>Remark</u>
0.0	1. Initial issue.	Aug. 22, 2007	Preliminary
0.1	1. Corrected errata. 2. Chapter 2.1 Detailed Product Description revised. 3. Chapter 2.2 Definitions revised. 4. Chapter 2.8.3 Device ID Register F001h(R) revised. 5. Chapter 2.8.8 Technology Register F006h(R) revised. 6. Chapter 2.8.10 Start Address2 Register F101h(R/W) revised. 7. Chapter 2.8.16 Start Address8 Register F107h(R/W) revised. 8. Chapter 2.8.17 Start Buffer Register F200h (R/W) revised. 9. Chapter 2.8.18 Command Register F220h(R/W) revised. 10. Chapter 2.8.22 Interrupt Status Register F241h(R/W) revised. 11. Chapter 3.1 Command Based Operation revised. 12. Chapter 3.1.2 Load Data Into Buffer Command revised. 13. Chapter 3.3 Reset Mode Operation revised. 14. Chapter 3.4.3 NAND Array Write Protection States revised. 15. Chapter 3.4.3.1 Unlocked NAND Array Write Protection State revised. 16. Chapter 3.4.3.3 Locked-tight NAND Array Write Protection State revised. 17. Chapter 3.4.4 NAND Flash Array Write Protection State Diagram revised. 18. Chapter 3.6.2 LSB Page Recovery Read revised. 19. Chapter 3.7.2 Synchronous Read Mode Operation revised. 20. Chapter 3.7.2.1 Continuous Linear Burst Read Operation revised. 21. Chapter 3.9 Program Operation revised. 22. Chapter 3.9.1 Cache Program Operation revised. 23. Chapter 3.9.2 Interleave Cache Program Operation revised. 24. Chapter 3.11.1 Block Erase Operation revised. 25. Chapter 3.11.2 Erase Suspend / Erase Resume Operation revised. 26. Chapter 3.12 Partition Information (PI) Block(SLC Only) revised. 27. Chapter 3.12.1 PI Block Boundary Information setting revised. 28. Chapter 3.12.1.1 PI Block Access mode entry revised. 29. Chapter 3.12.1.2 PI Block Erase revised. 30. Chapter 3.12.1.3 PI Block Program Operation revised. 31. Chapter 3.12.1.4 PI Update revised. 32. Chapter 3.13 OTP Operation (SLC only) revised. 33. Chapter 3.13.1 OTP Block Load Operation revised. 34. Chapter 3.15.2 Invalid Block Replacement Operation revised. 35. Chapter 5.5 AC Characteristics for Asynchronous Read revised. 36. Chapter 6.11 Superload Operation Timing revised. 37. Chapter 6.12 Program Operation Timing tINTW removed. 38. Chapter 6.15 Block Erase Operation Timing tINTW removed. 39. Chapter 7.4 DDP and QDP Description inserted.	Nov. 02, 2007	Preliminary
1.0	1. New Format(font size, color etc.) 2. Corrected errata. 3. Added a comment(Chapter 3.11.1 & 3.12.1.2 & 3.12.1.3 & 3.12.1.4) 4. Chapter 1.0 INTRODUCTION revised. 5. Chapter 2.8.17 Start Buffer Register F200h (R/W) revised. 6. Chapter 3.12.2 PI Block Load Operation revised. 7. Chapter 4.3 DC Characteristics revised.	Feb. 04, 2008	Final

<u>Revision No.</u>	<u>History</u>	<u>Draft Date</u>	<u>Remark</u>
1.1	<ol style="list-style-type: none">Chapter 3.5 Data Protection During Power Down Operation revised.Chapter 3.6.2 LSB Page Recovery read flow chart revised.Chapter 3.9.1 Cache Program Operation revised.Chapter 3.13.1 OTP Block Read Operation Flow Chart revised.Chapter 3.13.2 OTP Block Program Operation Flow Chart revised.Chapter 3.13.3 OTP Block Lock Operation Flow Chart revised.Chapter 3.13.4 1st Block OTP Lock Operation revised.Chapter 3.13.5 OTP and 1st Block OTP Lock Operation Flow Chart revised.Chapter 5.7 AC Characteristics for Asynchronous Write revised.Chapter 6.20 Data Protection Timing During Power Down revised.	Aug. 14, 2008	Final

1.0 INTRODUCTION

This specification contains information about the Samsung Electronics Company Flex-OneNAND™, Flash memory product family. Section 1.0 includes a general overview, revision history, and product ordering information.

Section 2.0 describes the Flex-OneNAND device. Section 3.0 provides information about device operation. Electrical specifications and timing waveforms are in Sections 4.0 through 6.0. Section 7.0 provides additional application and technical notes pertaining to use of the Flex-OneNAND. Package dimensions are found in Section 8.0

Density	Part No.	Vcc(core & IO)	Temperature	PKG
4Gb	KFG4GH6Q4M-DEBx	1.8V(1.7V~1.95V)	Extended	63FBGA(LF)
	KFG4GH6U4M-DIB6	3.3V(2.7V~3.6V)	Industrial	63FBGA(LF)
8Gb	KFH8GH6Q4M-DEBx	1.8V(1.7V~1.95V)	Extended	63FBGA(LF)
	KFH8GH6U4M-DIB6	3.3V(2.7V~3.6V)	Industrial	63FBGA(LF)
16Gb(TBD)	KFWAGH6Q4M-DEBx	1.8V(1.7V~1.95V)	Extended	63FBGA(LF)
	KFWAGH6U4M-DIB6	3.3V(2.7V~3.6V)	Industrial	63FBGA(LF)

1.1 Ordering Information

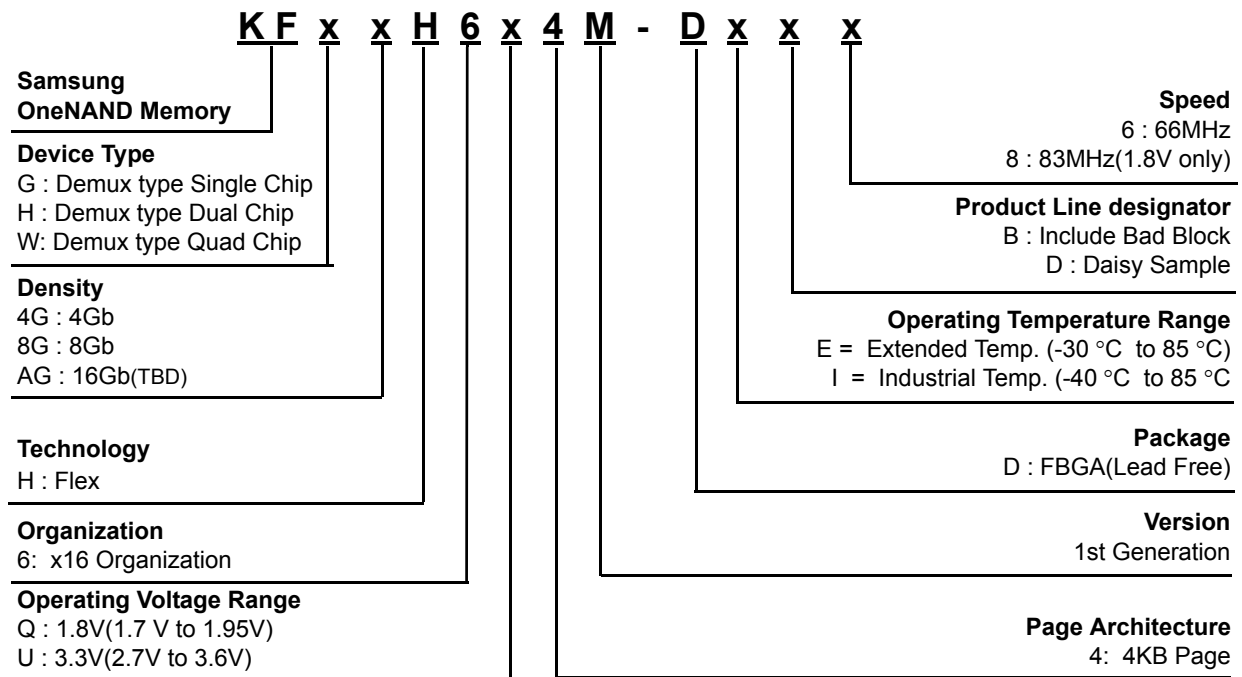

1.2 General Overview

Flex-OneNAND™ is a monolithic integrated circuit with a NAND Flash array using a NOR Flash interface.

The chip integrates system features including:

- A BootRAM(1KB) and bootloader
- 4KB DataRAM buffers
- A High-Speed x16 Host Interface
- On-chip Error Correction
- On-chip NOR interface controller

This on-chip integration enables system designers to reduce external system logic and use high-density NAND Flash in applications that would otherwise have to use more NOR components.

Flex-OneNAND takes advantage of the higher performance NAND program time, low power, and high density and combines it with the synchronous read performance of NOR. The NOR Flash host interface makes Flex-OneNAND an ideal solution for mobile applications that have large, advanced multimedia applications and operating systems and need high performance.

When integrated into a Samsung Multi-Chip-Package with Samsung Mobile DDR SDRAM, designers can complete a high-performance, small footprint solution.

The device operates up to a maximum host-driven clock frequency of 66MHz / 83MHz for synchronous reads at Vcc(or Vccq. Refer to chapter 4.2) with 4~7-clock latency. Appropriate wait cycles are determined by programmable read latency.

Flex-OneNAND provides for multiple sector read operations by assigning the number of sectors to be read in the sector counter register. The device includes one block-sized OTP (One Time Programmable) area and user-controlled 1st block OTP(Block 0) that can be used to increase system security or to provide identification capabilities.

1.3 Product Features

Difference between 1.8V product and 3.3V product in terms of functions.

	1.8V	3.3V
Synchronous Read	up to 83Mhz	up to 66Mhz
SuperLoad (Sync. read mode only)	○ (83Mhz)	○ (66Mhz)
Synchronous Write	up to 83Mhz	Async Only
Cache Program	○	X
Interleaving Cache Program	○	X
Interleaving Erase	○	○
Interleaving Program	○	○

Device Architecture

- Design Technology:
- Supply Voltage:
- Host Interface:
- 5KB Internal BufferRAM:
- NAND Array:

M die
1.8V (1.7V ~ 1.95V), 3.3V(2.7V~3.6V)
16 bit
1KB BootRAM, 4KB DataRAM
SLC : (4K+128)B Page Size
(256K+8K)B Block Size (64pages)
MLC : (4K+128)B Page Size
(512K+16K)B Block Size (128pages)

Device Performance

- Host Interface Type:

Synchronous Burst Read
- Up to 66MHz / 83MHz(1.8V only) clock frequency
- Linear Burst 4-, 8-, 16-, 32-words with wrap around
- Continuous 1K words Sequential Burst
Synchronous Write (1.8V only)
- Up to 66MHz / 83MHz clock frequency
- Linear Burst 4-, 8-, 16-, 32-, 1K-words with wrap around
- Continuous 1K words Sequential Burst

Asynchronous Random Read

- 76ns access time

Asynchronous Random Write

Latency 3,4(Default),5,6 and 7.
1~40MHz : Latency 3 available
1~66MHz : Latency 4,5,6 and 7 available
Over 66MHz : Latency 6,7 available.

Cold/Warm/Hot/NAND Flash Core Reset

Typical Power (Single chip),

- Standby current : 10uA@1.8V, 35uA@3.3V
- Synchronous Burst Read current(66MHz) : 20mA@1.8V, 30mA@3.3V
- Synchronous Burst Read current(83MHz) : 25mA@1.8V
- Synchronous Burst Write current(66MHz/83MHz) : 20/25mA@1.8V
- Load current : 50mA@1.8V, 55mA@3.3V
- Program current : 35mA@1.8V, 40mA@3.3V
- Erase current : 40mA@1.8V, 40mA@3.3V

- Programmable Burst Read Latency:

- Multiple Reset Modes:
- Low Power Dissipation:

- Reliable CMOS Floating-Gate Technology

- Endurance : 50K Program/Erase Cycles (SLC)
10K Program/Erase Cycles (MLC)
- Data Retention : 10 Years(SLC) /10 Years(MLC)

System Hardware

- Voltage detector generating internal reset signal from Vcc
- Hardware reset input (\overline{RP})
- Data Protection Modes

- Write Protection for BootRAM
- Write Protection for NAND Flash Array
- Write Protection during power-up
- Write Protection during power-down

- User-controlled One Time Programmable(OTP) area
- Internal 4bit ECC
- Internal Bootloader supports Booting Solution in system
- Handshaking Feature

- INT pin indicates Ready / Busy
- Polling the interrupt register status bit
- by ID register

- Detailed chip information

Package size

- 4G products
- 8G products
- 16G products(TBD)

63ball, 10mm x 13mm x max 1.0mmt , 0.8mm ball pitch FBGA
63ball, 10mm x 13mm x max 1.2mmt , 0.8mm ball pitch FBGA
63ball, 10mm x 13mm x max 1.4mmt , 0.8mm ball pitch FBGA (TBD)

2.0 DEVICE DESCRIPTION

2.1 Detailed Product Description

The Flex-OneNAND is an advanced generation, high-performance MLC NAND-based Flash memory(Which can be programmed as both SLC and MLC).

It integrates on-chip a convertible(SLC and MLC) NAND Flash Array memory with two independent data buffers, boot RAM buffer, a page buffer for the Flash array, and a one-time-programmable block.

The combination of these memory areas enable high-speed pipelining of reads from host, BufferRAM, Page Buffer, and NAND Flash Array.

Clock speeds up to 66MHz / 83MHz with a x16 wide I/O yields a 83MByte/second in SLC and 71MByte/second in MLC read bandwidth

The Flex-OneNAND also includes a Boot RAM and boot loader. This enables the device to efficiently load boot code at device startup from the NAND Array without the need for off-chip boot device.

One block of the NAND Array is set aside as an OTP memory area, and 1st Block (Block 0) can be used as OTP area. This area, available to the user, can be configured and locked with secured user information.

On-chip controller interfaces enable the device to operate in systems without NAND Host controllers.

2.2 Definitions

B (capital letter)	Byte, 8bits
W (capital letter)	Word, 16bits
b (lower-case letter)	Bit
ECC	Error Correction Code
Calculated ECC	ECC that has been calculated during a load or program access
Written ECC	ECC that has been stored as data in the NAND Flash array or in the BufferRAM
BufferRAM	On-chip internal buffer consisting of BootRAM and DataRAM
BootRAM	A 1KB portion of the BufferRAM reserved for Boot Code buffering
DataRAM	A 4KB portion of the BufferRAM reserved for Data buffering (2KB x2)
Sector	Part of a Page of which 512B is the main data area and 16B is the spare data area.
Data unit	Possible data unit to be read from memory to BufferRAM or to be programmed to memory. - 4224B of which 4096 is in main area and 128B in spare area
DDP	Dual Die Package
QDP	Quad Die Package
OTP	One Time Programmable

2.3 Pin Configuration

2.3.1 4Gb (KFG4GH6x4M) / 8Gb (KFH8GH6x4M)

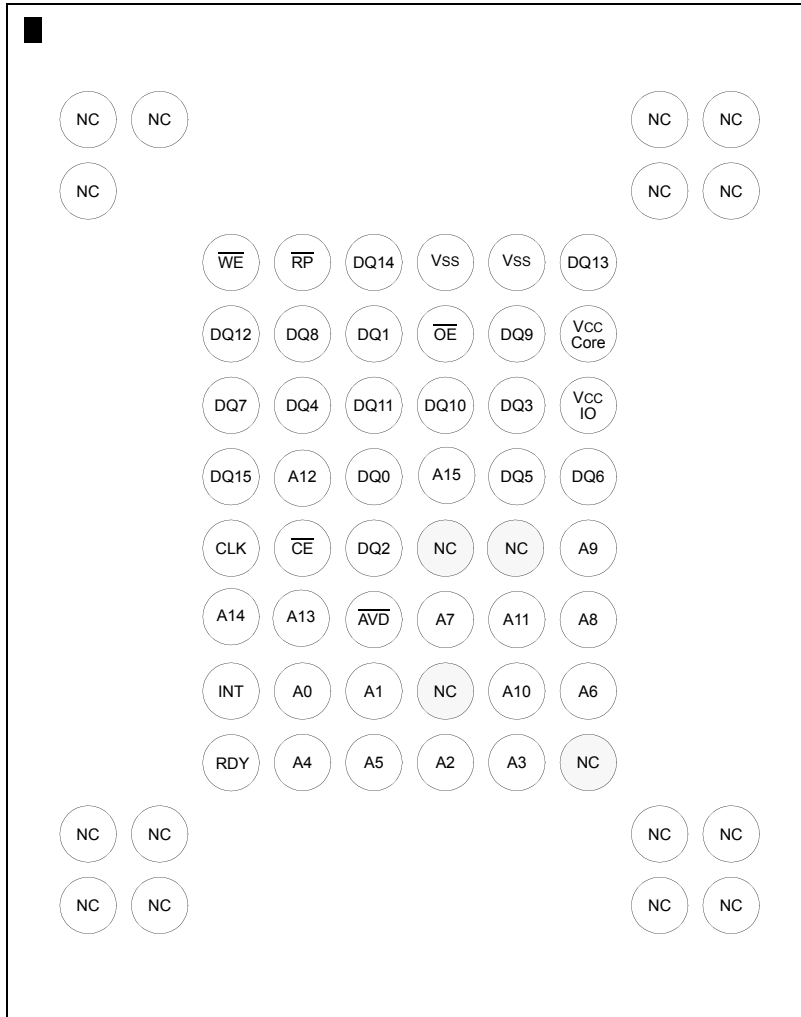

(TOP VIEW, Balls Facing Down)

63ball FBGA Flex-OneNAND Chip

63ball, 10mm x 13mm x max 1.0mmt , 0.8mm ball pitch FBGA(4Gb)

63ball, 10mm x 13mm x max 1.2mmt , 0.8mm ball pitch FBGA (8Gb)

2.3.2 16Gb Product (KFWAGH6x4M) (TBD)

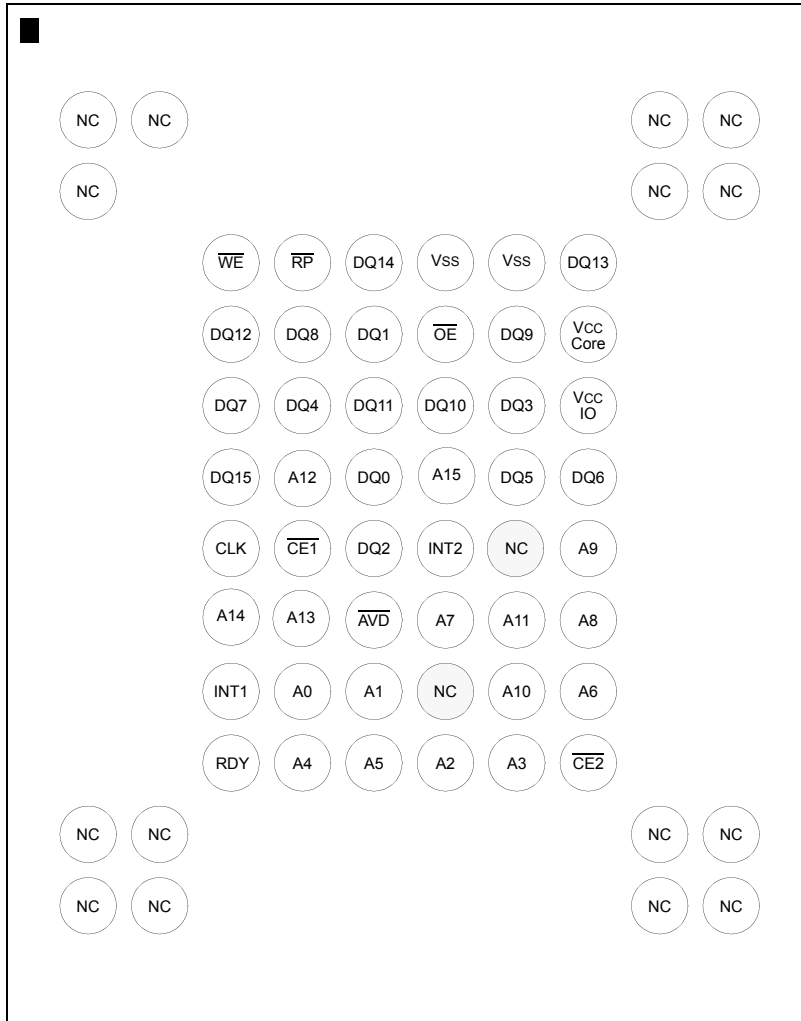

(TOP VIEW, Balls Facing Down)
 63ball FBGA OneNAND Chip
 63ball, 10mm x 13mm x max 1.4mmt , 0.8mm ball pitch FBGA

2.4 Pin Description

Pin Name	Type	Name and Description
Host Interface		
A15~A0	I	Address Inputs - Inputs for addresses during read and write operation, which are for addressing BufferRAM & Register.
DQ15~DQ0	I/O	Data Inputs/Outputs - Inputs data during program and commands for all operations, outputs data during memory array/register read cycles. Data pins float to high-impedance when the chip is deselected or outputs are disabled.
INT / INT1	O	Interrupt Notifies the Host when a command is completed. After power-up, it is at hi-z condition. Once IOBE is set to 1, it does not float to hi-z condition even when \overline{CE} is disabled or \overline{OE} is disabled. Especially, only when reset(Cold, Warm, Hot, NAND Flash Core) command in DDP are issued, it operates as open drain output with internal resistor (~50Kohm). The INT is the interrupt for Single or DDP device. The INT1 is the interrupt for the first DDP device(KFH8GH6x4M) in QDP(KFWAGH6x4M)
INT2	O	Interrupt The INT2 is the interrupt for the second DDP device(KFH8GH6x4M) in QDP(KFWAGH6x4M)
RDY	O	Ready Indicates data valid in synchronous read modes and is activated while \overline{CE} is low
CLK	I	Clock CLK synchronizes the device to the system bus frequency in synchronous read mode. The first rising edge of CLK in conjunction with \overline{AVD} low latches address input.
\overline{WE}	I	Write Enable \overline{WE} controls writes to the bufferRAM and registers. Data are latched on the \overline{WE} pulse's rising edge
\overline{AVD}	I	Address Valid Detect Indicates valid address presence on address inputs. During asynchronous read operation, all addresses are valid while \overline{AVD} is low, and during synchronous read operation, all addresses are latched on CLK's rising edge while \overline{AVD} is held low for one clock cycle. > Low : for asynchronous mode, indicates valid address; for burst mode, causes starting address to be latched on rising edge on CLK > High : device ignores address inputs
\overline{RP}	I	Reset Pin When low, \overline{RP} resets internal operation of Flex-OneNAND. \overline{RP} status is do not care during power-up and bootloading. When high, \overline{RP} level must be equivalent to Vcc-IO / Vccq level.
$\overline{CE} / \overline{CE1}$	I	Chip Enable \overline{CE} -low activates internal control logic, and \overline{CE} -high deselected the device, places it in standby state, and places DQ in Hi-Z. The \overline{CE} input enables device for Single or DDP . The $\overline{CE1}$ input enables the first DDP device(KFH8GH6x4M) in QDP(KFWAGH6x4M)
$\overline{CE2}$	I	Chip Enable The $\overline{CE2}$ input enables the second DDP device(KFH8GH6x4M) in QDP(KFWAGH6x4M)
\overline{OE}	I	Output Enable \overline{OE} -low enables the device's output data buffers during a read cycle.
Power Supply		
VCC-Core / Vcc		Power for Flex-OneNAND Core This is the power supply for Flex-OneNAND Core.
VCC-IO / Vccq		Power for Flex-OneNAND I/O This is the power supply for Flex-OneNAND I/O Vcc-IO / Vccq is internally separated from Vcc-Core / Vcc.
VSS		Ground for Flex-OneNAND
etc.		
DNU		Do Not Use Leave it disconnected. These pins are used for testing.
NC		No Connection Lead is not internally connected.

NOTE :
Do not leave power supply(Vcc-Core/Vcc-IO, VSS) disconnected.

2.5 Block Diagram

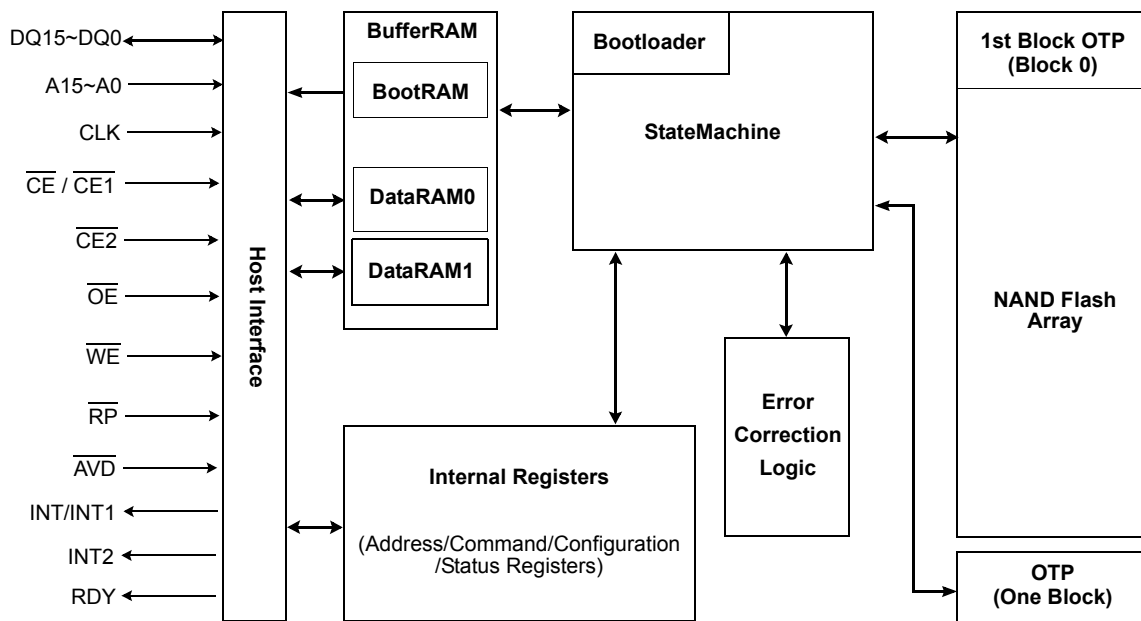

2.6 Memory Array Organization

The Flex-OneNAND architecture integrates several memory areas on a single chip.

2.6.1 Internal (NAND Array) Memory Organization

The on-chip internal memory is a convertible(SLC and MLC) NAND array used for data storage and code. The internal memory is divided into a main area and a spare area.

Main Area

The main area is the primary memory array. A block incorporates 64pages(SLC) or 128pages(MLC). A main page size is 4KB and a main page is comprised of 8 sectors each size of which is 512Byte.

Spare Area

The spare area is used for invalid block information and ECC storage. Spare area internal memory is associated with corresponding main area memory. A spare page size is 128B and a spare page is comprised of 8 sectors each size of which is 16Byte.

Internal Memory Array Information

Area	Block	Page	Sector
Main(SLC)	256KB	4KB	512B
Main(MLC)	512KB		
Spare(SLC)	8KB	128B	16B
Spare(MLC)	16KB		

Internal Memory Array Organizatio

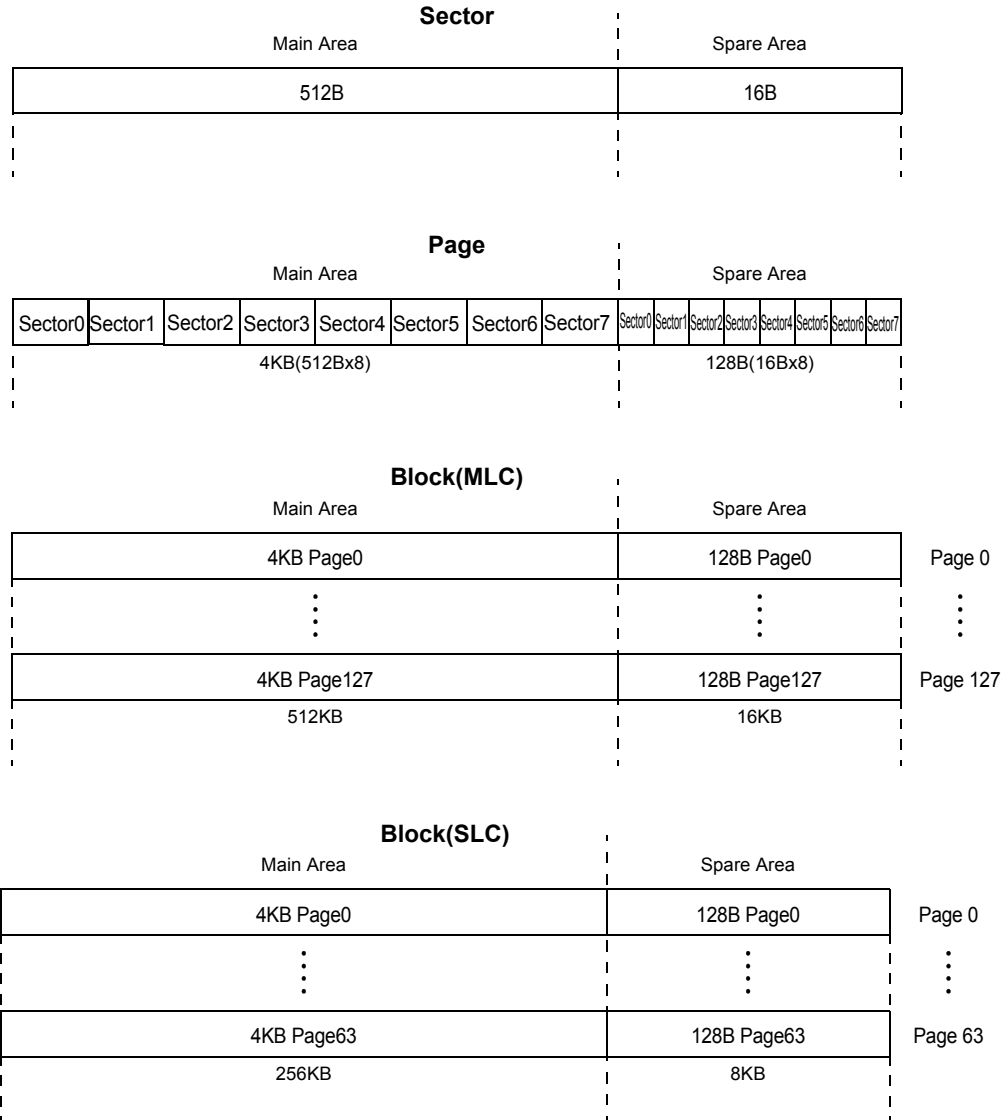

2.6.2 External (BufferRAM) Memory Organization

The on-chip external memory is comprised of 3 buffers used for Boot Code storage and data buffering.

The BootRAM is a buffer that receives Boot Code from the internal memory and makes it available to the host at start up.

There are 4KB bi-directional data buffers(2KB x2), DataRAM0 and DataRAM1. During Boot Up, the BootRam is used by the host to initialize the main memory, and deliver boot code from NAND Flash core to host.

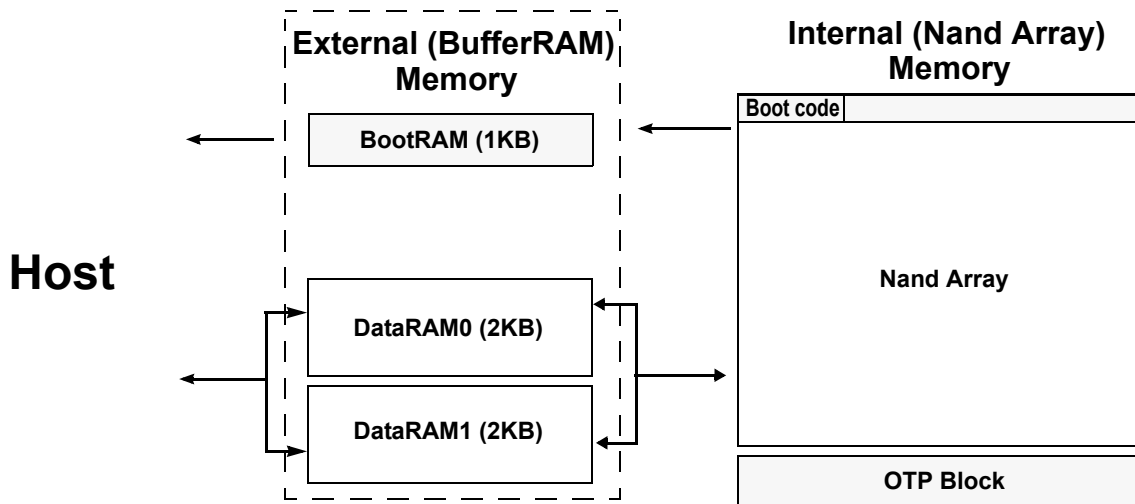

The external memory is divided into a main area and a spare area. Each buffer is the equivalent size of a Sector. The main area data is 512B. The spare area data is 16B.

External Memory Array Information

Area		BootRAM	DataRAM0	DataRAM1
Total Size		1KB+32B	2KB+64B	2KB+64B
Number of Sectors		2	4	4
Sector	Main	512B	512B	512B
	Spare	16B	16B	16B

External Memory Array Organization

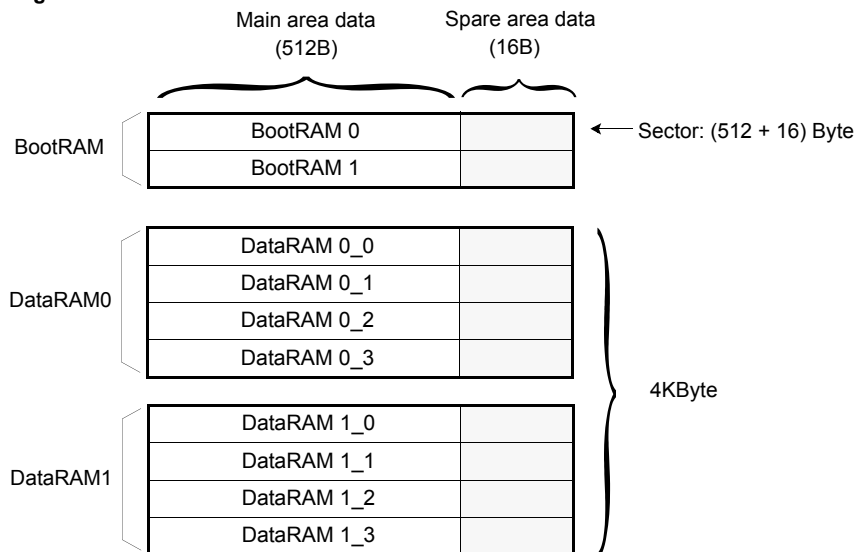

2.7 Memory Map

The following tables are the memory maps for the Flex-OneNAND.

2.7.1 Internal (NAND Array) Memory Organization

The following tables show the Internal Memory address map in word order.

Block	Block Address [F100h]	Page Address [F107h]	Size	Block	Block Address [F100h]	Page Address [F107h]	Size
Block0	0000h	0000h~00FCh	256KB	Block32	0020h	SLC: 0000h~00FCh*, MLC: 0000h~01FCh*	SLC: 256KB, MLC: 512KB
Block1	0001h	SLC: 0000h~00FCh*, MLC: 0000h~01FCh*	256KB, MLC: 512KB	Block33	0021h		
Block2	0002h			Block34	0022h		
Block3	0003h			Block35	0023h		
Block4	0004h			Block36	0024h		
Block5	0005h			Block37	0025h		
Block6	0006h			Block38	0026h		
Block7	0007h			Block39	0027h		
Block8	0008h			Block40	0028h		
Block9	0009h			Block41	0029h		
Block10	000Ah			Block42	002Ah		
Block11	000Bh			Block43	002Bh		
Block12	000Ch			Block44	002Ch		
Block13	000Dh			Block45	002Dh		
Block14	000Eh			Block46	002Eh		
Block15	000Fh			Block47	002Fh		
Block16	0010h			Block48	0030h		
Block17	0011h			Block49	0031h		
Block18	0012h			Block50	0032h		
Block19	0013h			Block51	0033h		
Block20	0014h			Block52	0034h		
Block21	0015h			Block53	0035h		
Block22	0016h			Block54	0036h		
Block23	0017h			Block55	0037h		
Block24	0018h			Block56	0038h		
Block25	0019h			Block57	0039h		
Block26	001Ah			Block58	003Ah		
Block27	001Bh			Block59	003Bh		
Block28	001Ch			Block60	003Ch		
Block29	001Dh			Block61	003Dh		
Block30	001Eh			Block62	003Eh		
Block31	001Fh			Block63	003Fh		

* Only four sectors are addressable, see Start Address Register .

Block	Block Address [F100h]	Page Address [F107h]	Size	Block	Block Address [F100h]	Page Address [F107h]	Size
Block64	0040h	SLC: 0000h~00FCh, MLC: 0000h~01FCh	SLC: 256KB, MLC: 512KB	Block96	0060h	SLC: 0000h~00FCh, MLC: 0000h~01FCh	SLC: 256KB, MLC: 512KB
Block65	0041h			Block97	0061h		
Block66	0042h			Block98	0062h		
Block67	0043h			Block99	0063h		
Block68	0044h			Block100	0064h		
Block69	0045h			Block101	0065h		
Block70	0046h			Block102	0066h		
Block71	0047h			Block103	0067h		
Block72	0048h			Block104	0068h		
Block73	0049h			Block105	0069h		
Block74	004Ah			Block106	006Ah		
Block75	004Bh			Block107	006Bh		
Block76	004Ch			Block108	006Ch		
Block77	004Dh			Block109	006Dh		
Block78	004Eh			Block110	006Eh		
Block79	004Fh			Block111	006Fh		
Block80	0050h			Block112	0070h		
Block81	0051h			Block113	0071h		
Block82	0052h			Block114	0072h		
Block83	0053h			Block115	0073h		
Block84	0054h			Block116	0074h		
Block85	0055h			Block117	0075h		
Block86	0056h			Block118	0076h		
Block87	0057h			Block119	0077h		
Block88	0058h			Block120	0078h		
Block89	0059h			Block121	0079h		
Block90	005Ah			Block122	007Ah		
Block91	005Bh			Block123	007Bh		
Block92	005Ch			Block124	007Ch		
Block93	005Dh			Block125	007Dh		
Block94	005Eh			Block126	007Eh		
Block95	005Fh			Block127	007Fh		

Block	Block Address [F100h]	Page Address [F107h]	Size	Block	Block Address [F100h]	Page Address [F107h]	Size
Block128	0080h	SLC: 0000h~00FCh, MLC: 0000h~01FCh	SLC: 256KB, MLC: 512KB	Block160	00A0h	SLC: 0000h~00FCh, MLC: 0000h~01FCh	SLC: 256KB, MLC: 512KB
Block129	0081h			Block161	00A1h		
Block130	0082h			Block162	00A2h		
Block131	0083h			Block163	00A3h		
Block132	0084h			Block164	00A4h		
Block133	0085h			Block165	00A5h		
Block134	0086h			Block166	00A6h		
Block135	0087h			Block167	00A7h		
Block136	0088h			Block168	00A8h		
Block137	0089h			Block169	00A9h		
Block138	008Ah			Block170	00AAh		
Block139	008Bh			Block171	00ABh		
Block140	008Ch			Block172	00ACh		
Block141	008Dh			Block173	00ADh		
Block142	008Eh			Block174	00AEh		
Block143	008Fh			Block175	00AFh		
Block144	0090h			Block176	00B0h		
Block145	0091h			Block177	00B1h		
Block146	0092h			Block178	00B2h		
Block147	0093h			Block179	00B3h		
Block148	0094h			Block180	00B4h		
Block149	0095h			Block181	00B5h		
Block150	0096h			Block182	00B6h		
Block151	0097h			Block183	00B7h		
Block152	0098h			Block184	00B8h		
Block153	0099h			Block185	00B9h		
Block154	009Ah			Block186	00BAh		
Block155	009Bh			Block187	00BBh		
Block156	009Ch			Block188	00BCh		
Block157	009Dh			Block189	00BDh		
Block158	009Eh			Block190	00BEh		
Block159	009Fh			Block191	00BFh		

Block	Block Address [F100h]	Page Address [F107h]	Size	Block	Block Address [F100h]	Page Address [F107h]	Size
Block192	00C0h			Block224	00E0h		
Block193	00C1h			Block225	00E1h		
Block194	00C2h			Block226	00E2h		
Block195	00C3h			Block227	00E3h		
Block196	00C4h			Block228	00E4h		
Block197	00C5h			Block229	00E5h		
Block198	00C6h			Block230	00E6h		
Block199	00C7h			Block231	00E7h		
Block200	00C8h			Block232	00E8h		
Block201	00C9h			Block233	00E9h		
Block202	00CAh			Block234	00EAh		
Block203	00CBh			Block235	00EBh		
Block204	00CCh			Block236	00ECh		
Block205	00CDh			Block237	00EDh		
Block206	00CEh			Block238	00EEh		
Block207	00CFh			Block239	00EFh		
Block208	00D0h			Block240	00F0h		
Block209	00D1h			Block241	00F1h		
Block210	00D2h			Block242	00F2h		
Block211	00D3h			Block243	00F3h		
Block212	00D4h			Block244	00F4h		
Block213	00D5h			Block245	00F5h		
Block214	00D6h			Block246	00F6h		
Block215	00D7h	Block247	00F7h				
Block216	00D8h	Block248	00F8h				
Block217	00D9h	Block249	00F9h				
Block218	00DAh	Block250	00FAh				
Block219	00DBh	Block251	00FBh				
Block220	00DCh	Block252	00FCh				
Block221	00DDh	Block253	00FDh				
Block222	00DEh	Block254	00FEh				
Block223	00DFh	Block255	00FFh				

SLC:
0000h~00FCh,

MLC:
0000h~01FCh

SLC:
256KB,

MLC:
512KB

SLC:
0000h~00FCh,

MLC:
0000h~01FCh

SLC:
256KB,

MLC:
512KB

Flex-OneNAND4G(KFG4GH6x4M-DxBx)
Flex-OneNAND8G(KFH8GH6x4M-DxBx)
Flex-OneNAND16G(KFWAGH6x4M-DxBx)

FLASH MEMORY

Block	Block Address [F100h]	Page Address [F107h]	Size	Block	Block Address [F100h]	Page Address [F107h]	Size
Block256	0100h	SLC: 0000h~00FCh, MLC: 0000h~01FCh	SLC: 256KB, MLC: 512KB	Block288	0120h	SLC: 0000h~00FCh, MLC: 0000h~01FCh	SLC: 256KB, MLC: 512KB
Block257	0101h			Block289	0121h		
Block258	0102h			Block290	0122h		
Block259	0103h			Block291	0123h		
Block260	0104h			Block292	0124h		
Block261	0105h			Block293	0125h		
Block262	0106h			Block294	0126h		
Block263	0107h			Block295	0127h		
Block264	0108h			Block296	0128h		
Block265	0109h			Block297	0129h		
Block266	010Ah			Block298	012Ah		
Block267	010Bh			Block299	012Bh		
Block268	010Ch			Block300	012Ch		
Block269	010Dh			Block301	012Dh		
Block270	010Eh			Block302	012Eh		
Block271	010Fh			Block303	012Fh		
Block272	0110h			Block304	0130h		
Block273	0111h			Block305	0131h		
Block274	0112h			Block306	0132h		
Block275	0113h			Block307	0133h		
Block276	0114h			Block308	0134h		
Block277	0115h			Block309	0135h		
Block278	0116h			Block310	0136h		
Block279	0117h			Block311	0137h		
Block280	0118h			Block312	0138h		
Block281	0119h			Block313	0139h		
Block282	011Ah			Block314	013Ah		
Block283	011Bh			Block315	013Bh		
Block284	011Ch	Block316	013Ch				
Block285	011Dh	Block317	013Dh				
Block286	011Eh	Block318	013Eh				
Block287	011Fh	Block319	013Fh				

Block	Block Address [F100h]	Page Address [F107h]	Size	Block	Block Address [F100h]	Page Address [F107h]	Size
Block320	0140h	SLC: 0000h~00FCh, MLC: 0000h~01FCh	SLC: 256KB, MLC: 512KB	Block352	0160h	SLC: 0000h~00FCh, MLC: 0000h~01FCh	SLC: 256KB, MLC: 512KB
Block321	0141h			Block353	0161h		
Block322	0142h			Block354	0162h		
Block323	0143h			Block355	0163h		
Block324	0144h			Block356	0164h		
Block325	0145h			Block357	0165h		
Block326	0146h			Block358	0166h		
Block327	0147h			Block359	0167h		
Block328	0148h			Block360	0168h		
Block329	0149h			Block361	0169h		
Block330	014Ah			Block362	016Ah		
Block331	014Bh			Block363	016Bh		
Block332	014Ch			Block364	016Ch		
Block333	014Dh			Block365	016Dh		
Block334	014Eh			Block366	016Eh		
Block335	014Fh			Block367	016Fh		
Block336	0150h			Block368	0170h		
Block337	0151h			Block369	0171h		
Block338	0152h			Block370	0172h		
Block339	0153h			Block371	0173h		
Block340	0154h			Block372	0174h		
Block341	0155h			Block373	0175h		
Block342	0156h			Block374	0176h		
Block343	0157h			Block375	0177h		
Block344	0158h			Block376	0178h		
Block345	0159h			Block377	0179h		
Block346	015Ah			Block378	017Ah		
Block347	015Bh			Block379	017Bh		
Block348	015Ch			Block380	017Ch		
Block349	015Dh			Block381	017Dh		
Block350	015Eh			Block382	017Eh		
Block351	015Fh			Block383	017Fh		

Block	Block Address [F100h]	Page Address [F107h]	Size	Block	Block Address [F100h]	Page Address [F107h]	Size
Block384	0180h	SLC: 0000h~00FCh, MLC: 0000h~01FCh	SLC: 256KB, MLC: 512KB	Block416	01A0h	SLC: 0000h~00FCh, MLC: 0000h~01FCh	SLC: 256KB, MLC: 512KB
Block385	0181h			Block417	01A1h		
Block386	0182h			Block418	01A2h		
Block387	0183h			Block419	01A3h		
Block388	0184h			Block420	01A4h		
Block389	0185h			Block421	01A5h		
Block390	0186h			Block422	01A6h		
Block391	0187h			Block423	01A7h		
Block392	0188h			Block424	01A8h		
Block393	0189h			Block425	01A9h		
Block394	018Ah			Block426	01AAh		
Block395	018Bh			Block427	01ABh		
Block396	018Ch			Block428	01ACh		
Block397	018Dh			Block429	01ADh		
Block398	018Eh			Block430	01AEh		
Block399	018Fh			Block431	01AFh		
Block400	0190h			Block432	01B0h		
Block401	0191h			Block433	01B1h		
Block402	0192h			Block434	01B2h		
Block403	0193h			Block435	01B3h		
Block404	0194h			Block436	01B4h		
Block405	0195h			Block437	01B5h		
Block406	0196h			Block438	01B6h		
Block407	0197h			Block439	01B7h		
Block408	0198h			Block440	01B8h		
Block409	0199h			Block441	01B9h		
Block410	019Ah			Block442	01BAh		
Block411	019Bh			Block443	01BBh		
Block412	019Ch			Block444	01BCh		
Block413	019Dh			Block445	01BDh		
Block414	019Eh			Block446	01BEh		
Block415	019Fh			Block447	01BFh		

Block	Block Address [F100h]	Page Address [F107h]	Size	Block	Block Address [F100h]	Page Address [F107h]	Size
Block448	01C0h	SLC: 0000h~00FCh, MLC: 0000h~01FCh	SLC: 256KB, MLC: 512KB	Block480	01E0h	SLC: 0000h~00FCh, MLC: 0000h~01FCh	SLC: 256KB, MLC: 512KB
Block449	01C1h			Block481	01E1h		
Block450	01C2h			Block482	01E2h		
Block451	01C3h			Block483	01E3h		
Block452	01C4h			Block484	01E4h		
Block453	01C5h			Block485	01E5h		
Block454	01C6h			Block486	01E6h		
Block455	01C7h			Block487	01E7h		
Block456	01C8h			Block488	01E8h		
Block457	01C9h			Block489	01E9h		
Block458	01CAh			Block490	01EAh		
Block459	01CBh			Block491	01EBh		
Block460	01CCh			Block492	01ECh		
Block461	01CDh			Block493	01EDh		
Block462	01CEh			Block494	01EEh		
Block463	01CFh			Block495	01EFh		
Block464	01D0h			Block496	01F0h		
Block465	01D1h			Block497	01F1h		
Block466	01D2h			Block498	01F2h		
Block467	01D3h			Block499	01F3h		
Block468	01D4h			Block500	01F4h		
Block469	01D5h			Block501	01F5h		
Block470	01D6h			Block502	01F6h		
Block471	01D7h			Block503	01F7h		
Block472	01D8h			Block504	01F8h		
Block473	01D9h			Block505	01F9h		
Block474	01DAh			Block506	01FAh		
Block475	01DBh			Block507	01FBh		
Block476	01DCh			Block508	01FCh		
Block477	01DDh			Block509	01FDh		
Block478	01DEh			Block510	01FEh		
Block479	01DFh			Block511	01FFh		

Block	Block Address [F100h]	Page Address [F107h]	Size	Block	Block Address [F100h]	Page Address [F107h]	Size
Block512	0200h	SLC: 0000h~00FCh, MLC: 0000h~01FCh	SLC: 256KB, MLC: 512KB	Block544	0220h	SLC: 0000h~00FCh, MLC: 0000h~01FCh	SLC: 256KB, MLC: 512KB
Block513	0201h			Block545	0221h		
Block514	0202h			Block546	0222h		
Block515	0203h			Block547	0223h		
Block516	0204h			Block548	0224h		
Block517	0205h			Block549	0225h		
Block518	0206h			Block550	0226h		
Block519	0207h			Block551	0227h		
Block520	0208h			Block552	0228h		
Block521	0209h			Block553	0229h		
Block522	020Ah			Block554	022Ah		
Block523	020Bh			Block555	022Bh		
Block524	020Ch			Block556	022Ch		
Block525	020Dh			Block557	022Dh		
Block526	020Eh			Block558	022Eh		
Block527	020Fh			Block559	022Fh		
Block528	0210h			Block560	0230h		
Block529	0211h			Block561	0231h		
Block530	0212h			Block562	0232h		
Block531	0213h			Block563	0233h		
Block532	0214h			Block564	0234h		
Block533	0215h			Block565	0235h		
Block534	0216h			Block566	0236h		
Block535	0217h			Block567	0237h		
Block536	0218h			Block568	0238h		
Block537	0219h			Block569	0239h		
Block538	021Ah			Block570	023Ah		
Block539	021Bh			Block571	023Bh		
Block540	021Ch			Block572	023Ch		
Block541	021Dh			Block573	023Dh		
Block542	021Eh			Block574	023Eh		
Block543	021Fh			Block575	023Fh		

Flex-OneNAND4G(KFG4GH6x4M-DxBx)
Flex-OneNAND8G(KFH8GH6x4M-DxBx)
Flex-OneNAND16G(KFWAGH6x4M-DxBx)

FLASH MEMORY

Block	Block Address [F100h]	Page Address [F107h]	Size	Block	Block Address [F100h]	Page Address [F107h]	Size
Block576	0240h	SLC: 0000h~00FCh, MLC: 0000h~01FCh	SLC: 256KB, MLC: 512KB	Block608	0260h	SLC: 0000h~00FCh, MLC: 0000h~01FCh	SLC: 256KB, MLC: 512KB
Block577	0241h			Block609	0261h		
Block578	0242h			Block610	0262h		
Block579	0243h			Block611	0263h		
Block580	0244h			Block612	0264h		
Block581	0245h			Block613	0265h		
Block582	0246h			Block614	0266h		
Block583	0247h			Block615	0267h		
Block584	0248h			Block616	0268h		
Block585	0249h			Block617	0269h		
Block586	024Ah			Block618	026Ah		
Block587	024Bh			Block619	026Bh		
Block588	024Ch			Block620	026Ch		
Block589	024Dh			Block621	026Dh		
Block590	024Eh			Block622	026Eh		
Block591	024Fh			Block623	026Fh		
Block592	0250h			Block624	0270h		
Block593	0251h			Block625	0271h		
Block594	0252h			Block626	0272h		
Block595	0253h			Block627	0273h		
Block596	0254h			Block628	0274h		
Block597	0255h			Block629	0275h		
Block598	0256h			Block630	0276h		
Block599	0257h			Block631	0277h		
Block600	0258h			Block632	0278h		
Block601	0259h			Block633	0279h		
Block602	025Ah			Block634	027Ah		
Block603	025Bh			Block635	027Bh		
Block604	025Ch			Block636	027Ch		
Block605	025Dh			Block637	027Dh		
Block606	025Eh			Block638	027Eh		
Block607	025Fh			Block639	027Fh		

Block	Block Address [F100h]	Page Address [F107h]	Size	Block	Block Address [F100h]	Page Address [F107h]	Size
Block640	0280h	SLC: 0000h~00FCh, MLC: 0000h~01FCh	SLC: 256KB, MLC: 512KB	Block672	02A0h	SLC: 0000h~00FCh, MLC: 0000h~01FCh	SLC: 256KB, MLC: 512KB
Block641	0281h			Block673	02A1h		
Block642	0282h			Block674	02A2h		
Block643	0283h			Block675	02A3h		
Block644	0284h			Block676	02A4h		
Block645	0285h			Block677	02A5h		
Block646	0286h			Block678	02A6h		
Block647	0287h			Block679	02A7h		
Block648	0288h			Block680	02A8h		
Block649	0289h			Block681	02A9h		
Block650	028Ah			Block682	02AAh		
Block651	028Bh			Block683	02ABh		
Block652	028Ch			Block684	02ACh		
Block653	028Dh			Block685	02ADh		
Block654	028Eh			Block686	02AEh		
Block655	028Fh			Block687	02AFh		
Block656	0290h			Block688	02B0h		
Block657	0291h			Block689	02B1h		
Block658	0292h			Block690	02B2h		
Block659	0293h			Block691	02B3h		
Block660	0294h			Block692	02B4h		
Block661	0295h			Block693	02B5h		
Block662	0296h			Block694	02B6h		
Block663	0297h			Block695	02B7h		
Block664	0298h			Block696	02B8h		
Block665	0299h			Block697	02B9h		
Block666	029Ah			Block698	02BAh		
Block667	029Bh			Block699	02BBh		
Block668	029Ch			Block700	02BCh		
Block669	029Dh			Block701	02BDh		
Block670	029Eh			Block702	02BEh		
Block671	029Fh			Block703	02BFh		

**Flex-OneNAND4G(KFG4GH6x4M-DxBx)
 Flex-OneNAND8G(KFH8GH6x4M-DxBx)
 Flex-OneNAND16G(KFWAGH6x4M-DxBx)**

FLASH MEMORY

Block	Block Address [F100h]	Page Address [F107h]	Size	Block	Block Address [F100h]	Page Address [F107h]	Size
Block704	02C0h	SLC: 0000h~00FCh, MLC: 0000h~01FCh	SLC: 256KB, MLC: 512KB	Block736	02E0h	SLC: 0000h~00FCh, MLC: 0000h~01FCh	SLC: 256KB, MLC: 512KB
Block705	02C1h			Block737	02E1h		
Block706	02C2h			Block738	02E2h		
Block707	02C3h			Block739	02E3h		
Block708	02C4h			Block740	02E4h		
Block709	02C5h			Block741	02E5h		
Block710	02C6h			Block742	02E6h		
Block711	02C7h			Block743	02E7h		
Block712	02C8h			Block744	02E8h		
Block713	02C9h			Block745	02E9h		
Block714	02CAh			Block746	02EAh		
Block715	02CBh			Block747	02EBh		
Block716	02CCh			Block748	02ECh		
Block717	02CDh			Block749	02EDh		
Block718	02CEh			Block750	02EEh		
Block719	02CFh			Block751	02EFh		
Block720	02D0h			Block752	02F0h		
Block721	02D1h			Block753	02F1h		
Block722	02D2h			Block754	02F2h		
Block723	02D3h			Block755	02F3h		
Block724	02D4h			Block756	02F4h		
Block725	02D5h			Block757	02F5h		
Block726	02D6h			Block758	02F6h		
Block727	02D7h			Block759	02F7h		
Block728	02D8h			Block760	02F8h		
Block729	02D9h			Block761	02F9h		
Block730	02DAh			Block762	02FAh		
Block731	02DBh			Block763	02FBh		
Block732	02DCh			Block764	02FCh		
Block733	02DDh			Block765	02FDh		
Block734	02DEh			Block766	02FEh		
Block735	02DFh			Block767	02FFh		

**Flex-OneNAND4G(KFG4GH6x4M-DxBx)
 Flex-OneNAND8G(KFH8GH6x4M-DxBx)
 Flex-OneNAND16G(KFWAGH6x4M-DxBx)**

FLASH MEMORY

Block	Block Address [F100h]	Page Address [F107h]	Size	Block	Block Address [F100h]	Page Address [F107h]	Size
Block768	0300h	SLC: 0000h~00FCh, MLC: 0000h~01FCh	SLC: 256KB, MLC: 512KB	Block800	0320h	SLC: 0000h~00FCh, MLC: 0000h~01FCh	SLC: 256KB, MLC: 512KB
Block769	0301h			Block801	0321h		
Block770	0302h			Block802	0322h		
Block771	0303h			Block803	0323h		
Block772	0304h			Block804	0324h		
Block773	0305h			Block805	0325h		
Block774	0306h			Block806	0326h		
Block775	0307h			Block807	0327h		
Block776	0308h			Block808	0328h		
Block777	0309h			Block809	0329h		
Block778	030Ah			Block810	032Ah		
Block779	030Bh			Block811	032Bh		
Block780	030Ch			Block812	032Ch		
Block781	030Dh			Block813	032Dh		
Block782	030Eh			Block814	032Eh		
Block783	030Fh			Block815	032Fh		
Block784	0310h			Block816	0330h		
Block785	0311h			Block817	0331h		
Block786	0312h			Block818	0332h		
Block787	0313h			Block819	0333h		
Block788	0314h			Block820	0334h		
Block789	0315h			Block821	0335h		
Block790	0316h			Block822	0336h		
Block791	0317h			Block823	0337h		
Block792	0318h			Block824	0338h		
Block793	0319h			Block825	0339h		
Block794	031Ah			Block826	033Ah		
Block795	031Bh			Block827	033Bh		
Block796	031Ch			Block828	033Ch		
Block797	031Dh			Block829	033Dh		
Block798	031Eh			Block830	033Eh		
Block799	031Fh			Block831	033Fh		

Flex-OneNAND4G(KFG4GH6x4M-DxBx)
Flex-OneNAND8G(KFH8GH6x4M-DxBx)
Flex-OneNAND16G(KFWAGH6x4M-DxBx)

FLASH MEMORY

Block	Block Address [F100h]	Page Address [F107h]	Size	Block	Block Address [F100h]	Page Address [F107h]	Size
Block832	0340h	SLC: 0000h~00FCh, MLC: 0000h~01FCh	SLC: 256KB, MLC: 512KB	Block864	0360h	SLC: 0000h~00FCh, MLC: 0000h~01FCh	SLC: 256KB, MLC: 512KB
Block833	0341h			Block865	0361h		
Block834	0342h			Block866	0362h		
Block835	0343h			Block867	0363h		
Block836	0344h			Block868	0364h		
Block837	0345h			Block869	0365h		
Block838	0346h			Block870	0366h		
Block839	0347h			Block871	0367h		
Block840	0348h			Block872	0368h		
Block841	0349h			Block873	0369h		
Block842	034Ah			Block874	036Ah		
Block843	034Bh			Block875	036Bh		
Block844	034Ch			Block876	036Ch		
Block845	034Dh			Block877	036Dh		
Block846	034Eh			Block878	036Eh		
Block847	034Fh			Block879	036Fh		
Block848	0350h			Block880	0370h		
Block849	0351h			Block881	0371h		
Block850	0352h			Block882	0372h		
Block851	0353h			Block883	0373h		
Block852	0354h			Block884	0374h		
Block853	0355h			Block885	0375h		
Block854	0356h			Block886	0376h		
Block855	0357h			Block887	0377h		
Block856	0358h			Block888	0378h		
Block857	0359h			Block889	0379h		
Block858	035Ah			Block890	037Ah		
Block859	035Bh			Block891	037Bh		
Block860	035Ch			Block892	037Ch		
Block861	035Dh			Block893	037Dh		
Block862	035Eh			Block894	037Eh		
Block863	035Fh			Block895	037Fh		

Flex-OneNAND4G(KFG4GH6x4M-DxBx)
Flex-OneNAND8G(KFH8GH6x4M-DxBx)
Flex-OneNAND16G(KFWAGH6x4M-DxBx)

FLASH MEMORY

Block	Block Address [F100h]	Page Address [F107h]	Size	Block	Block Address [F100h]	Page Address [F107h]	Size
Block896	0380h	SLC: 0000h~00FCh, MLC: 0000h~01FCh	SLC: 256KB, MLC: 512KB	Block928	03A0h	SLC: 0000h~00FCh, MLC: 0000h~01FCh	SLC: 256KB, MLC: 512KB
Block897	0381h			Block929	03A1h		
Block898	0382h			Block930	03A2h		
Block899	0383h			Block931	03A3h		
Block900	0384h			Block932	03A4h		
Block901	0385h			Block933	03A5h		
Block902	0386h			Block934	03A6h		
Block903	0387h			Block935	03A7h		
Block904	0388h			Block936	03A8h		
Block905	0389h			Block937	03A9h		
Block906	038Ah			Block938	03AAh		
Block907	038Bh			Block939	03ABh		
Block908	038Ch			Block940	03ACh		
Block909	038Dh			Block941	03ADh		
Block910	038Eh			Block942	03AEh		
Block911	038Fh			Block943	03AFh		
Block912	0390h			Block944	03B0h		
Block913	0391h			Block945	03B1h		
Block914	0392h			Block946	03B2h		
Block915	0393h			Block947	03B3h		
Block916	0394h			Block948	03B4h		
Block917	0395h			Block949	03B5h		
Block918	0396h			Block950	03B6h		
Block919	0397h			Block951	03B7h		
Block920	0398h			Block952	03B8h		
Block921	0399h			Block953	03B9h		
Block922	039Ah			Block954	03BAh		
Block923	039Bh	Block955	03BBh				
Block924	039Ch	Block956	03BCh				
Block925	039Dh	Block957	03BDh				
Block926	039Eh	Block958	03BEh				
Block927	039Fh	Block959	03BFh				

**Flex-OneNAND4G(KFG4GH6x4M-DxBx)
 Flex-OneNAND8G(KFH8GH6x4M-DxBx)
 Flex-OneNAND16G(KFWAGH6x4M-DxBx)**

FLASH MEMORY

Block	Block Address [F100h]	Page Address [F107h]	Size	Block	Block Address [F100h]	Page Address [F107h]	Size
Block960	03C0h	SLC: 0000h~00FCh, MLC: 0000h~01FCh	SLC: 256KB, MLC: 512KB	Block992	03E0h	SLC: 0000h~00FCh, MLC: 0000h~01FCh	SLC: 256KB, MLC: 512KB
Block961	03C1h			Block993	03E1h		
Block962	03C2h			Block994	03E2h		
Block963	03C3h			Block995	03E3h		
Block964	03C4h			Block996	03E4h		
Block965	03C5h			Block997	03E5h		
Block966	03C6h			Block998	03E6h		
Block967	03C7h			Block999	03E7h		
Block968	03C8h			Block1000	03E8h		
Block969	03C9h			Block1001	03E9h		
Block970	03CAh			Block1002	03EAh		
Block971	03CBh			Block1003	03EBh		
Block972	03CCh			Block1004	03ECh		
Block973	03CDh			Block1005	03EDh		
Block974	03CEh			Block1006	03EEh		
Block975	03CFh			Block1007	03EFh		
Block976	03D0h			Block1008	03F0h		
Block977	03D1h			Block1009	03F1h		
Block978	03D2h			Block1010	03F2h		
Block979	03D3h			Block1011	03F3h		
Block980	03D4h			Block1012	03F4h		
Block981	03D5h			Block1013	03F5h		
Block982	03D6h			Block1014	03F6h		
Block983	03D7h			Block1015	03F7h		
Block984	03D8h			Block1016	03F8h		
Block985	03D9h			Block1017	03F9h		
Block986	03DAh			Block1018	03FAh		
Block987	03DBh			Block1019	03FBh		
Block988	03DCh			Block1020	03FCh		
Block989	03DDh			Block1021	03FDh		
Block990	03DEh			Block1022	03FEh		
Block991	03DFh			Block1023	03FFh		

2.7.2 Internal Memory Spare Area Assignment

The figure below shows the assignment of the spare area in the Internal Memory NAND Array.

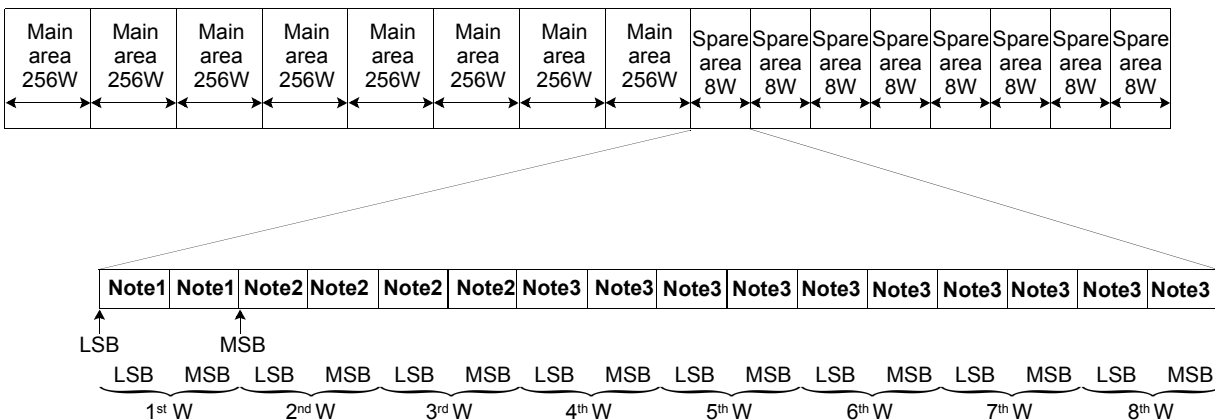

Spare Area Assignment in the Internal Memory NAND Array Information

Word	Byte	Note	Description
1	LSB	1	Invalid Block information in 1st and 2nd page of an invalid block
	MSB		
2	LSB	2	Managed by internal ECC logic for Logical Sector Number area
	MSB		
3	LSB	2	Managed by internal ECC logic for Logical Sector Number area
	MSB		
4	LSB	3	4bit ECC parity values
	MSB		
5	LSB	3	
	MSB		
6	LSB	3	
	MSB		
7	LSB	3	
	MSB		
8	LSB	3	
	MSB		

2.7.3 External Memory (BufferRAM) Address Map

The following table shows the External Memory address map in Word and Byte Order.

Note that the data output is unknown while host reads a register bit of reserved area and dual buffering is not applicable.

Division	Address (word order)	Address (byte order)	Size (total 128KB)		Usage	Description			
Main area (64KB)	0000h~00FFh	00000h~001FEh	512B	1KB	R	BootM 0	BootRAM, Main, block0/page0/sector0		
	0100h~01FFh	00200h~003FEh	512B			BootM 1	BootRAM, Main, block0/page0/sector1		
	0200h~02FFh	00400h~005FEh	512B	4KB	R/W	DataM 0_0	DataRAM, Main, nth page/sector0		
	0300h~03FFh	00600h~007FEh	512B			DataM 0_1	DataRAM, Main, nth page/sector1		
	0400h~04FFh	00800h~009FEh	512B			DataM 0_2	DataRAM, Main, nth page/sector2		
	0500h~05FFh	00A00h~00BFEh	512B			DataM 0_3	DataRAM, Main, nth page/sector3		
	0600h~06FFh	00C00h~00DFEh	512B			DataM 1_0	DataRAM, Main, nth page/sector4		
	0700h~07FFh	00E00h~00FFEh	512B			DataM 1_1	DataRAM, Main, nth page/sector5		
	0800h~08FFh	01000h~011FEh	512B			DataM 1_2	DataRAM, Main, nth page/sector6		
	0900h~09FFh	01200h~013FEh	512B			DataM 1_3	DataRAM, Main, nth page/sector7		
	0A00h~7FFFh	01400h~0FFFEh	59K			59K	-	Reserved	Reserved
	Spare area (8KB)	8000h~8007h	10000h~1000Eh			16B	32B	R	BootS 0
8008h~800Fh		10010h~1001Eh	16B	BootS 1	BootRAM, Spare, block0/page0/sector1				
8010h~8017h		10020h~1002Eh	16B	128B	R/W	DataS 0_0	DataRAM, Spare, nth page/sector0		
8018h~801Fh		10030h~1003Eh	16B			DataS 0_1	DataRAM, Spare, nth page/sector1		
8020h~8027h		10040h~1004Eh	16B			DataS 0_2	DataRAM, Spare, nth page/sector2		
8028h~802Fh		10050h~1005Eh	16B			DataS 0_3	DataRAM, Spare, nth page/sector3		
8030h~8037h		10060h~1006Eh	16B			DataS 1_0	DataRAM, Spare, nth page/sector4		
8038h~803Fh		10070h~1007Eh	16B			DataS 1_1	DataRAM, Spare, nth page/sector5		
8040h~8047h		10080h~1008Eh	16B			DataS 1_2	DataRAM, Spare, nth page/sector6		
8048h~804Fh		10090h~1009Eh	16B			DataS 1_3	DataRAM, Spare, nth page/sector7		
8050h~8FFFh		100A0h~11FFEh	8032B			8032B	-	Reserved	Reserved
Reserved (24KB)		9000h~BFFFh	12000h~17FFEh			24KB	24KB	-	Reserved
Reserved (8KB)	C000h~CFFFh	18000h~19FFEh	8KB	8KB	-	Reserved	Reserved		
Reserved (16KB)	D000h~EFFFh	1A000h~1DFFEh	16KB	16KB	-	Reserved	Reserved		
Registers (8KB)	F000h~FFFFh	1E000h~1FFFEh	8KB	8KB	R or R/W	Registers	Registers		

2.7.4 External Memory Map Detail Information

The tables below show Word Order Address Map information for the BootRAM and DataRAM main and spare areas.

• BootRAM(Main area)

-0000h~01FFh: 2(sector) x 512byte(NAND main area) = 1KB

0000h~00FFh(512B) BootM 0 (sector 0 of page 0/block 0)	0100h~01FFh(512B) BootM 1 (sector 1 of page 0/block 0)
--	--

• DataRAM(Main area)

-0200h~09FFh: 8(sector) x 512byte(NAND main area) = 4KB

0200h~02FFh(512B) DataM 0_0 (sector 0 of nth page)	0300h~03FFh(512B) DataM 0_1 (sector 1 of nth page)	0400h~04FFh(512B) DataM 0_2 (sector 2 of nth page)	0500h~05FFh(512B) DataM 0_3 (sector 3 of nth page)
0600h~06FFh(512B) DataM 1_0 (sector 4 of nth page)	0700h~07FFh(512B) DataM 1_1 (sector 5 of nth page)	0800h~08FFh(512B) DataM 1_2 (sector 6 of nth page)	0900h~09FFh(512B) DataM 1_3 (sector 7 of nth page)

• BootRAM(Spare area)

-8000h~800Fh: 2(sector) x 16byte(NAND spare area) = 32B

8000h~8007h(16B) BootS 0 (sector 0 of page 0/block 0)	8008h~800Fh(16B) BootS 1 (sector 1 of page 0/block 0)
---	---

• DataRAM(Spare area)

-8010h~804Fh: 8(sector) x 16byte(NAND spare area) = 128B

8010h~8017h(16B) DataS 0_0 (sector 0 of nth page)	8018h~801Fh(16B) DataS 0_1 (sector 1 of nth page)	8020h~8027h(16B) DataS 0_2 (sector 2 of nth page)	8028h~802Fh(16B) DataS 0_3 (sector 3 of nth page)
8030h~8037h(16B) DataS 1_0 (sector 4 of nth page)	8038h~803Fh(16B) DataS 1_1 (sector 5 of nth page)	8040h~8047h(16B) DataS 1_2 (sector 6 of nth page)	8048h~804Fh(16B) DataS 1_3 (sector 7 of nth page)

*NAND Flash array consists of 4KB page size and 256KB(SLC)/512KB(MLC) block size.

2.7.5 External Memory Spare Area Assignment

← Equivalent to 1word of NAND Flash →

Buf.	Word Address	Byte Address	F	E	D	C	B	A	9	8	7	6	5	4	3	2	1	0
BootS 0	8000h	10000h	BI(Bad block Information)															
	8001h	10002h	Managed by internal ECC logic															
	8002h	10004h																
	8003h	10006h																
	8004h	10008h																
	8005h	1000Ah	4bit ECC parity values															
	8006h	1000Ch																
BootS 1	8007h	1000Eh																
	8008h	10010h	BI(Bad block Information)															
	8009h	10012h	Managed by internal ECC logic															
	800Ah	10014h																
	800Bh	10016h																
	800Ch	10018h																
	800Dh	1001Ah	4bit ECC parity values															
DataS 0_0	800Eh	1001Ch																
	800Fh	1001Eh																
	8010h	10020h	BI(Bad block Information)															
	8011h	10022h	Managed by internal ECC logic															
	8012h	10024h																
	8013h	10026h																
	8014h	10028h																
8015h	1002Ah	4bit ECC parity values																
DataS 0_1	8016h	1002Ch																
	8017h	1002Eh																
	8018h	10030h	BI(Bad block Information)															
	8019h	10032h	Managed by internal ECC logic															
	801Ah	10034h																
	801Bh	10036h																
	801Ch	10038h																
801Dh	1003Ah	4bit ECC parity values																
	801Eh	1003Ch																
	801Fh	1003Eh																

Buf.	Word Address	Byte Address	F	E	D	C	B	A	9	8	7	6	5	4	3	2	1	0
DataS 0_2	8020h	10040h	BI(Bad block Information)															
	8021h	10042h	Managed by internal ECC logic															
	8022h	10044h																
	8023h	10046h																
	8024h	10048h																
	8025h	1004Ah	4bit ECC parity values															
	8026h	1004Ch																
	8027h	1004Eh																
DataS 0_3	8028h	10050h	BI(Bad block Information)															
	8029h	10052h	Managed by internal ECC logic															
	802Ah	10054h																
	802Bh	10056h																
	802Ch	10058h																
	802Dh	1005Ah	4bit ECC parity values															
	802Eh	1005Ch																
	802Fh	1005Eh																
DataS 1_0	8030h	10060h	BI(Bad block Information)															
	8031h	10062h	Managed by internal ECC logic															
	8032h	10064h																
	8033h	10066h																
	8034h	10068h																
	8035h	1006Ah	4bit ECC parity values															
	8036h	1006Ch																
	8037h	1006Eh																
DataS 1_1	8038h	10070h	BI(Bad block Information)															
	8039h	10072h	Managed by internal ECC logic															
	803Ah	10074h																
	803Bh	10076h																
	803Ch	10078h																
	803Dh	1007Ah	4bit ECC parity values															
	803Eh	1007Ch																
	803Fh	1007Eh																
DataS 1_2	8040h	10080h	BI(Bad block Information)															
	8041h	10082h	Managed by internal ECC logic															
	8042h	10084h																
	8043h	10086h																
	8044h	10088h																
	8045h	1008Ah	4bit ECC parity values															
	8046h	1008Ch																
	8047h	1008Eh																

← Equivalent to 1word of NAND Flash →

Buf.	Word Address	Byte Address	F	E	D	C	B	A	9	8	7	6	5	4	3	2	1	0
DataS 1_3	8048h	10090h	BI(Bad block Information)															
	8049h	10092h	Managed by internal ECC logic															
	804Ah	10094h																
	804Bh	10096h	4bit ECC parity values															
	804Ch	10098h																
	804Dh	1009Ah																
	804Eh	1009Ch																
	804Fh	1009Eh																

NOTE :

In case of 'with ECC' mode, Flex-OneNAND automatically generates ECC code for both main and spare data of memory during program operation, but does not update ECC code to spare bufferRAM during load operation.

2.8 Registers

Section 2.8 of this specification provides information about the Flex-OneNAND4G registers.

2.8.1 Register Address Map

This map describes the register addresses, register name, register description, and host accessibility.

Address (word order)	Address (byte order)	Name	Host Access	Description
F000h	1E000h	Manufacturer ID	R	Manufacturer identification
F001h	1E002h	Device ID	R	Device identification
F002h	1E004h	Version ID	R	N/A
F003h	1E006h	Data Buffer size	R	Data buffer size
F004h	1E008h	Boot Buffer size	R	Boot buffer size
F005h	1E00Ah	Amount of buffers	R	Amount of data/boot buffers
F006h	1E00Ch	Technology	R	Info about technology
F007h~F0FFh	1E00Eh~1E1FEh	Reserved	-	Reserved for user
F100h	1E200h	Start address 1	R/W	Chip address for selection of NAND Core in DDP & Block address
F101h	1E202h	Start address 2	R/W	Chip address for selection of BufferRAM in DDP
F102h~F106h	1E204h~1E20Ch	Reserved	-	Reserved for user
F107h	1E20Eh	Start address 8	R/W	NAND Flash Page & Sector Address
F108h~F1FFh	1E210h~1E3FEh	Reserved	-	Reserved for user
F200h	1E400h	Sector Count	R/W	Sector Number for the page data transfer from the memory and the BufferRAM
F201h~F21Fh	1E402h~1E43Eh	Reserved	-	Reserved for vendor specific purposes
F220h	1E440h	Command	R/W	Host control and memory operation commands
F221h	1E442h	System Configuration 1	R, R/W	memory and Host Interface Configuration
F222h~F22Fh	1E444h~1E45Eh	Reserved	-	Reserved for user
F230h~F23Fh	1E460h~1E47Eh	Reserved	-	Reserved for vendor specific purposes
F240h	1E480h	Controller Status	R	Controller Status and result of memory operation
F241h	1E482h	Interrupt	R/W	Memory Command Completion Interrupt Status
F242h~F24Bh	1E484h~1E496h	Reserved	-	Reserved for user
F24Ch	1E498h	Start Block Address	R/W	Start memory block address in Write Protection mode
F24Dh	1E49Ah	Reserved	-	Reserved for user
F24Eh	1E49Ch	Write Protection Status	R	Current memory Write Protection status (unlocked/locked/tight-locked)
F24Fh~FEFFh	1E49Eh~1FDfEh	Reserved	-	Reserved for user
FF00h	1FE00h	ECC Status Register 1	R	ECC status of sector0 and sector 1
FF01h	1FE02h	ECC Status Register 2	R	ECC status of sector2 and sector 3
FF02h	1FE04h	ECC Status Register 3	R	ECC status of sector4 and sector 5
FF03h	1FE06h	ECC Status Register 4	R	ECC status of sector6 and sector 7
FF04h~FFFFh	1FE08h~1FFFEh	Reserved	-	Reserved for vendor specific purposes

2.8.2 Manufacturer ID Register F000h (R)

This Read register describes the manufacturer's identification.
 Samsung Electronics Company manufacturer's ID is 00ECh.

F000h, default = 00ECh

15	14	13	12	11	10	9	8	7	6	5	4	3	2	1	0
ManufID															

2.8.3 Device ID Register F001h (R)

This Read register describes the device.

F001h, see table for default.

15	14	13	12	11	10	9	8	7	6	5	4	3	2	1	0
DeviceID															

Device Identification

Device Identification	Description
DeviceID [1:0] Vcc	00 = 1.8V, 01 = 3.3V, 10/11 = reserved
DeviceID [2] Muxed/Demuxed	0 = Muxed, 1 = Demuxed
DeviceID [3] Single/DDP	0 = Single, 1 = DDP/QDP
DeviceID [7:4] Density	0000 = 128Mb, 0001 = 256Mb, 0010 = 512Mb, 0011 = 1Gb, 0100 = 2Gb, 0101=4Gb, 0110=8Gb, 0111=16Gb
DeviceID [9:8] Separation	10=Flex[SLC&MLC], 01=MLC, 00=SLC, 11=reserved

Device ID Default

Device	DeviceID[15:0]
KFG4GH6Q4M	0254h
KFG4GH6U4M	0255H
KFH8GH6Q4M	026Ch
KFH8GH6U4M	026Dh
KFWAGH6Q4M	026Ch ¹⁾
KFWAGH6U4M	026Dh ¹⁾

NOTE :

1) The base density of all the three device is 4Gb, DDP and QDP use 2 and 4 multiplexed chips respectively, hence DDP and QDP device ID is same.

2.8.4 Version ID Register F002h

This register is reserved for future use.

2.8.5 Data Buffer Size Register F003h (R)

This Read register describes the size of the Data Buffer.

F003h, default = 0800h

15	14	13	12	11	10	9	8	7	6	5	4	3	2	1	0
DataBufSize															

Data Buffer Size Information

Version Identification	Description
DataBufSize	Total data buffer size in Words equal to 2 buffers of 1024 Words each (2 x 1024 = 2 ¹¹) in the memory interface

2.8.6 Boot Buffer Size Register F004h (R)

This Read register describes the size of the Boot Buffer.

F004h, default = 0200h

15	14	13	12	11	10	9	8	7	6	5	4	3	2	1	0
BootBufSize															

Register Information	Description
BootBufSize	Total boot buffer size in Words equal to 1 buffer of 512 Words (1 x 512 = 2 ⁹) in the memory interface

2.8.7 Amount of Buffers Register F005h (R)

This Read register describes the number of each Buffer.

F005h, default = 0201h

15	14	13	12	11	10	9	8	7	6	5	4	3	2	1	0
DataBufAmount								BootBufAmount							

Number of Buffers Information

Register Information	Description
DataBufAmount	The number of data buffers = 2 (2 ^N , N=1)
BootBufAmount	The number of boot buffers = 1 (2 ^N , N=0)

2.8.8 Technology Register F006h (R)

This Read register describes the internal NAND array technology.

F006h, default = 0001h

15	14	13	12	11	10	9	8	7	6	5	4	3	2	1	0
Tech															

Technology Information

Technology	Register Setting
NAND SLC	0000h
NAND MLC	0001h
Reserved	0002h ~ FFFFh

NOTE :
 Flex-OneNAND has underlying MLC technology.

2.8.9 Start Address1 Register F100h (R/W)

This Read/Write register describes the NAND Flash block address which will be loaded, programmed, or erased.

F100h, default = 0000h

15	14	13	12	11	10	9	8	7	6	5	4	3	2	1	0
DFS	Reserved(00000)					FBA									

Device	Number of Block	FBA
4Gb	1024	FBA[9:0]
8Gb DDP	2048	DFS[15] & FBA[9:0]

NOTE :
 For QDP, See Section 7.4

Start Address1 Information

Register Information	Description
FBA	NAND Flash Block Address
DFS	Flash Core of DDP (Device Flash Core Select)

2.8.10 Start Address2 Register F101h (R/W)

This Read/Write register describes the method to select the BufferRAM of DDP (Device BufferRAM Select)

F101h, default = 0000h

15	14	13	12	11	10	9	8	7	6	5	4	3	2	1	0
DBS	Reserved(0000000000000000)														

Start Address2 Information

Register Information	Description
DBS	BufferRAM and Register of DDP (Device BufferRAM Select)

- >DBS should be set to 1 when accessing the BufferRAM of the second chip(MSB chip) in a DDP.
- >Since DDP chip has 2 BufferRAMs multiplexed, the BufferRAM which corresponds to the Flash core that is intended to be accessed must be selected using DBS.
- >Data in BufferRAM of one chip is not accessible to the Flash Core of the other chip in a DDP See Section 7.4.

2.8.11~15 Start Address3~7 Register F102h~F106h

This Register is reserved for future use.

2.8.16 Start Address8 Register F107h (R/W)

This Read/Write register describes the NAND Flash start page address in a block for a page load, program operation and the NAND Flash start sector address in a page for a load, or program operation.

F107h, default = 0000h

15	14	13	12	11	10	9	8	7	6	5	4	3	2	1	0
Reserved (0000000)							FPA					FSA			

Start Address8 Information

Item	Description	Default Value	Range
FPA	NAND Flash Page Address	0000000	0000000 ~ 1111111, 7 bits for 128 pages ¹⁾
FSA	NAND Flash Sector Address	00	00 (sector0), 01 (sector1), 10 (Sector2), 11 (sector3)

NOTE :

- 1) Only 6bits must be used for 64pages in SLC area. (SLC:64pages, MLC:128pages)
- 2) Sectors 4-7 in a page are not directly addressable using FSA. However, they can be accessed using BSA and BSC (See Below).FSA must be 00 in program operation.

2.8.17 Start Buffer Register F200h (R/W)

This Buffer Sector Count(BSC) specifies the number of sectors to be loaded.

F200h, default = 0000h

15	14	13	12	11	10	9	8	7	6	5	4	3	2	1	0
Reserved(0000)				BSA ¹⁾				Reserved(00000)				BSC			

The BufferRAM Sector Address (BSA) is the sector 0~3 address in the internal BootRAM and DataRAM where data is placed.

NOTE :

- 1) In case of 'Program' and 'Load', Internally BSA fix first sector of DataRAM0(BSA=1000).

Item	Description	BSC Value	Number of Sectors
BSC (CASE1 : FSA=00)	Buffer Sector Count	000 (Default)	8 sectors
		001	1 sectors
		010	2 sectors
		011	3 sectors
		100	4 sectors
		101	5 sectors
		110	6 sectors
BSC (CASE2 : FSA=01)	Buffer Sector Count	001	1 sectors
		010	2 sectors
		011	3 sectors
BSC (CASE3 : FSA=10)	Buffer Sector Count	001	1 sectors
		010	2 sectors
BSC (CASE4 : FSA=11)	Buffer Sector Count	001	1 sectors

NOTE :

- 1) BSC is used only on load operation.
- 2) Operation not guaranteed for cases not defined in above table(CASE1, CASE2, CASE3,CASE4).

Sector allocation according to BSC(CASE1 : FSA=00)

BSC = 000	Sector0	Sector1	Sector2	Sector3	Sector4	Sector5	Sector6	Sector7
BSC = 001	Sector0							
BSC = 010	Sector0	Sector1						
BSC = 011	Sector0	Sector1	Sector2					
BSC = 100	Sector0	Sector1	Sector2	Sector3				
BSC = 101	Sector0	Sector1	Sector2	Sector3	Sector4			
BSC = 110	Sector0	Sector1	Sector2	Sector3	Sector4	Sector5		
BSC = 111	Sector0	Sector1	Sector2	Sector3	Sector4	Sector5	Sector6	

Sector allocation according to BSC(CASE2 : FSA=01)

BSC = 001	Sector1							
BSC = 010	Sector1	Sector2						
BSC = 011	Sector1	Sector2	Sector3					

Sector allocation according to BSC(CASE3 : FSA=10)

BSC = 001	Sector2							
BSC = 010	Sector2	Sector3						

Sector allocation according to BSC(CASE4 : FSA=11)

BSC = 001	Sector3							
-----------	---------	--	--	--	--	--	--	--

* The first sector from Flash(The first sector is determined by FSA. In case of FSA=01[CASE2], the first sector is Sector1.) is transferred to the 1st sector(sector0) of DataRAM0, and the other sectors are transferred sequentially.

2.8.18 Command Register F220h (R/W)

Command can be issued by two following methods, and user may select one way or the other to issue appropriate command;

1. Write command into Command Register when INT is at ready state. INT will automatically turn to busy state as command is issued. Once the desired operation is completed, INT will go back ready state.
2. Write 0000h to INT bit of Interrupt Status Register, and then write command into Command Register. Once the desired operation is completed, INT will go back to ready state.
 (00F0h and 00F3h may be accepted during busy state of some operations. Refer to the right most column of the command register table below.)

F220h, default = 0000h

15	14	13	12	11	10	9	8	7	6	5	4	3	2	1	0
Command															

CMD	Operation	Acceptable command during busy
0000h	Load a page unit into buffer	00F0h, 00F3h
0003h	Superload a page unit from buffer	00F0h, 00F3h
0005h	LSB page recovery Read ¹⁾ PI update ²⁾	00F0h, 00F3h
0080h	Program a page unit from buffer & Finish Program operation at Cache Program operation	00F0h, 00F3h
007Fh	Cache Program operation	00F0h, 00F3h
0023h	Unlock NAND array a block	00F0h, 00F3h
002Ah	Lock NAND array a block	00F0h, 00F3h
002Ch	Lock-tight NAND array a block	00F0h, 00F3h
0027h	All Block Unlock	00F0h, 00F3h
0094h	Block Erase	00F0h, 00F3h
00B0h	Erase Suspend	00F0h, 00F3h
0030h	Erase Resume	00F0h, 00F3h
00F0h	Reset NAND Flash Core	-
00F3h	Reset Flex-OneNAND ³⁾	-
0065h	OTP Access	00F0h, 00F3h
0066h	Access to Partition Information(PI) Block	00F0h, 00F3h

NOTE :

- 1) LSB page recovery Read command can always be issued but not in the PI Block access mode.
- 2) In PI Block Access mode, PI update can be issued.
- 3) 'Reset Flex-OneNAND'(=Hot reset) command makes the registers and NAND Flash core into default state.

2.8.18.1 Two Methods to Clear Interrupt Register in Command Input

To clear Interrupt Register in command input, user may select one from either following methods.

First method is to turn INT to low by manually writing 0000h to INT bit of Interrupt Register. ¹⁾

Second method is to input command while INT is high, and the device will automatically turn INT to low. ¹⁾
 (Second method is equivalent with method used in general NAND Flash)

User may choose the desirable method to clear Interrupt Register.

Method 1: Manually set INT=0 before writing command into Command Register: Manual INT Mode

(1) Clear Interrupt Register (F241h) by writing 0000h into INT bit of Interrupt Register. This operation will make INT pin turn low. ¹⁾

(2) Write command into Command Register. This will make the device to perform the designated operation.

(3) INT pin will turn back to high once the operation is completed. ¹⁾

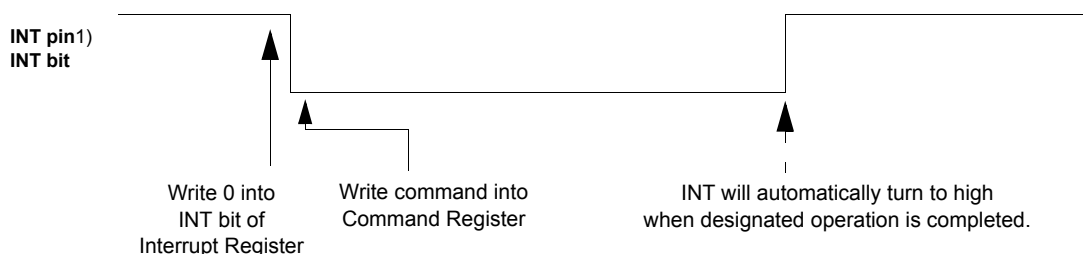

NOTE : 1) INT pin polarity is based on 'IOBE=1 and INT pol=1 (default)' setting

Method 2: Write command into Command Register at INT ready state: Auto INT Mode

(1) Write command into Command Register. This will automatically turn INT from high to low. ¹⁾

(2) INT pin will turn back to high once the operation is completed. ¹⁾

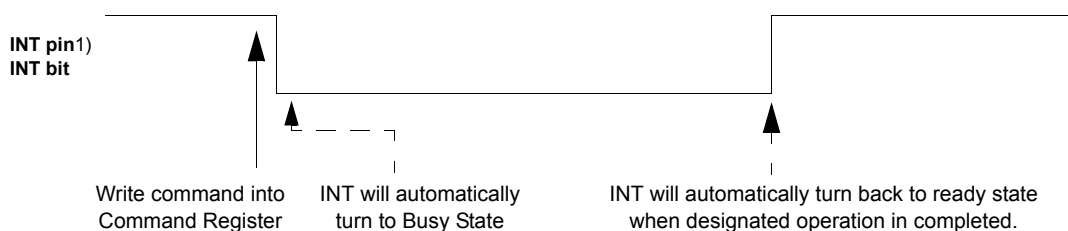

NOTE : 1) INT pin polarity is based on 'IOBE=1 and INT pol=1 (default)' setting

2.8.19 System Configuration 1 Register F221h (R, R/W)

This Read/Write register describes the system configuration.

F221h, default =40C0h

15	14	13	12	11	10	9	8	7	6	5	4	3	2	1	0
R/W	R/W			R/W			R/W	R/W	R/W	R/W	R/W	R	R/W	R/W	R
RM	BRWL			BL			ECC	RDY pol	INT pol	IOBE	RDY Conf	Reserv ed	HF	WM	BWPS

Read Mode (RM)

RM	Read Mode
0	Asynchronous read(default)
1	Synchronous read

Read Mode Information[15]

Item	Definition	Description
RM	Read Mode	Selects between asynchronous read mode and synchronous read mode

Burst Read Write Latency (BRWL)

BRWL	Latency Cycles (Read/Write)		
	under 40MHz (HF=0)	40MHz~66MHz (HF=0)	over 66MHz (HF=1)
000~010	Reserved		
011	3(up to 40MHz. min)	3(N/A)	3(N/A)
100 (default)	4	4(min.)	4(N/A)
101	5	5	5(N/A)
110	6	6	6(min.)
111	7	7	7

* Default value of BRWL and HF value is BRWL=4, HF=0.

For host frequency over 66MHz, BRWL should be 6 or 7 while HF is 1.

For host frequency range of 40MHz~66MHz, BRWL should be set to 4~7 while HF is 0.

For host frequency under 40MHz, BRWL should be set to 3~7 while HF is 0.

Burst Read Write Latency (BRWL) Information[14:12]

Item	Definition	Description
BRWL	Burst Read Latency / Burst Write Latency	Specifies the access latency in the burst read / write transfer for the initial access

Burst Length (BL)

Host must follow burst length set by BL when reading data in synchronous burst read.

BL	Burst Length(Main)	Burst Length(Spare)
000	Continuous(Default) ¹⁾	
001	4 words	
010	8 words	
011	16 words	
100	32 words	N/A
101~111	Reserved	

NOTE :

1) In case of BootRAM : Main=512word, Spare=16word
 In case of DataRAM : Main=1Kword, Spare=32word

Burst Length (BL) Information[11:9]

Item	Definition	Description
BL	Burst Length	Specifies the size of the burst length during a synchronous linear burst read and wrap around. And also burst length during a synchronous linear burst write

Error Correction Code (ECC) Information[8]

Item	Definition	Description
ECC	Error Correction Code Operation	0 = with correction (default) 1 = without correction (bypassed)

RDY Polarity (RDYpol) Information[7]

Item	Definition	Description
RDYpol	RDY signal polarity	1 = high for ready (default) 0 = low for ready

INT Polarity (INTpol) Information[6]

INTpol	INT bit of Interrupt Status Register	INT Pin output
0	0 (busy)	High
	1 (ready)	Low
1 (default)	0 (busy)	Low
	1 (ready)	High

I/O Buffer Enable (IOBE)

IOBE is the I/O Buffer Enable for the INT and RDY signals. At startup, INT and RDY outputs are High-Z. Bits 6 and 7 become valid after IOBE is set to "1". IOBE can be reset by a Cold Reset or by writing "0" to bit 5 of System Configuration1 Register.

I/O Buffer Enable Information[5]

Item	Definition	Description
IOBE	I/O Buffer Enable for INT and RDY signals	0 = disable (default) 1 = enable

RDY Configuration (RDY conf)

RDY Configuration Information[4]

Item	Definition	Description
RDY conf	RDY configuration	0=active one clock before valid data (default) 1=active with valid data

HF Enable (HF)

HF	Description
0	HF Disable (default, under 66MHz)
1	HF Enable (over 66MHz)

HF Information[2]

Item	Definition	Description
HF	High Frequency	Selects between HF Disable and HF Enable

Write Mode (WM)

Synchronous write operation is applicable only on 1.8V device

WM	Write Mode
0	Asynchronous Write(default)
1	Synchronous Write

Write Mode Information[1]

Item	Definition	Description
WM	Write Mode	Selects between asynchronous Write Mode and synchronous Write Mode

MRS(Mode Register Setting) Description

RM	WM	Mode Description
0	0	Asynch Read & Asynch Write (Default)
1	0	Sync Read & Asynch Write
1	1	Sync Read & Synch Write
Other Cases		Reserved ¹⁾

NOTE :

1) Operation not guaranteed for cases not defined in above table.

Boot Buffer Write Protect Status(BWPS)

Boot Buffer Write Protect Status Information[0]

Item	Definition	Description
BWPS	Boot Buffer Write Protect Status	0=locked(fixed)

2.8.20 System Configuration 2 Register F222h

This register is reserved for future use.

2.8.21 Controller Status Register F240h (R)

This Read register shows the overall internal status of the Flex-OneNAND and the controller.

F240h, default = 0000h

15	14	13	12	11	10	9	8	7	6	5	4	3	2	1	0
OnGo	Reserved(0000)				Error	Reser ved(0)	PI _L	Reser ved(0)	OTPL	OTP _{BL}	Reserved(00)		Previous	Current	TO (0)

OnGo

This bit shows the overall internal status of the Flex-OneNAND device.
 In Cache Program Operation, OnGo bit shows the overall status of Cache Program process.

OnGo Information[15]

Item	Definition	Description
OnGo	Internal Device Status	0 = ready 1 = busy

Error

This bit shows the overall Error status.
 In case of Cache Program, Error bit will show the accumulative error status of Cache Program operation, so that if an error occurs during Cache Program, this bit will stay as Fail status, until the end of Cache Program.

Error Information[10]

Error	Load Program, Cache Program, and Erase Result
0	Pass
1	Fail

PI Lock Status (PI_L)

This bit shows whether the PI block is locked or unlocked. Locking the PI has the effect of a 'Program/Erase protect' to guard against accidental re-programming of data stored in the PI block.
 The PI status bit is automatically updated at power-on and PI update operation by PI Update command.

OTP Lock Status (OTPL)

This bit shows whether the OTP block is locked or unlocked. Locking the OTP has the effect of a 'write-protect' to guard against accidental re-programming of data stored in the OTP block. The OTPL status bit is automatically updated at power-on.

OTP Lock Information[6]

OTPL	OTP Locked/Unlocked Status
0	OTP Block Unlock Status(Default)
1	OTP Block Lock Status(Disable OTP Program/Erase)

1st Block OTP Lock Status (OTPLBL)

This bit shows whether the 1st Block OTP is locked or unlocked. Locking the 1st Block OTP has the effect of a 'Program/Erase protect' to guard against accidental re-programming of data stored in the 1st block. The OTPLBL status bit is automatically updated at power-on.

OTP Lock Information[5]

OTPLBL	1st Block OTP Locked/Unlocked Status
0	1st Block OTP Unlock Status(Default)
1	1st Block OTPLock Status(Disable 1st Block OTP Program/Erase)

Previous Cache Program status (Previous)

This bit shows the previous program status of Cache Program. This value is invalid only at the first 'Read Controller Status Register' step of Cache Program operation. (Refer to 6.12 and 6.13)

Previous [2]

Previous	Status of previous program
0	Pass
1	Fail

Current Cache Program Status (Current)

This bit shows the current program status only at Final Cache Program.

Current Information[1]

Current	Status of current program
0	Pass
1	Fail

Time Out (TO)

This bit determines if there is a time out for load, program, and erase operations. It is fixed at 'no time out'.

TO Information[0]

Item	Definition	Description
TO	Time Out	0 = no time out

Controller Status Register Output Modes

Mode	Controller Status Register [15:0]													[2]	[1]	[0]
	[15]	[14]	[13]	[12]	[11]	[10]	[9]	[8]	[7]	[6]	[5]	[4]	[3]			
	OnGo	Reserved			Error	Reserved	PI _L ¹⁾	Reserved	OTP _L ²⁾	OTP _B _L ³⁾	Reserved	Previous	Current			
Operation Ongoing	1				0	0	0/1	0	0/1	0/1	00	0	0	0		
Operation OK	0				0		0/1		0/1	0/1		0	0	0		
Operation Fail	0				1		0/1		0/1	0		0	0	0		
Program fail on Cache Program	0				1		0/1		0/1	0		0	1	0		
Previous program fail during Cache Program	0				1		0/1		0/1	0		0	1	0		
Program fail after Finish Cache Program	0	0000			1		0/1		0/1	0		0/1	0/1	(Note 4)	(Note 4)	0
Reset during Program/Erase/Load	0				0		0/1		0/1	0		0/1	0/1	0	0	0
Program/Erase to the locked block, Load to the BootRAM	0				1		0/1		0/1	0		0/1	0/1	0	0	0
OTP Program Fail(Lock)	0				1		0/1		0/1	0		1	1	0	0	0
OTP Program Fail	0				1		0/1		0/1	0		0	0	0	0	0

NOTE :

- 1) "1" for PI_L Block Lock, "0" for PI_L Block Unlock.
- 2) "1" for 1st Block OTP Lock, "0" for 1st Block OTP Unlock.
- 3) "1" for OTP Block Lock, "0" for OTP Block Unlock.
- 4) After Finish Cache Program operation, pass/fail status of Current Cache Program and Previous Cache Program will be updated.

2.8.22 Interrupt Status Register F241h (R/W)

This Read/Write register shows status of the Flex-OneNAND interrupts.

F241h, defaults = 8080h after Cold Reset; 8010h after Warm/Hot Reset

15	14	13	12	11	10	9	8	7	6	5	4	3	2	1	0	
INT	Reserved(0000000)							RI	WI	EI	RSTI	Reserved(0000)				

Interrupt (INT)

This is the master interrupt bit. The INT bit is wired directly to the INT pin on the chip. Upon writing '0' to the INT bit, the INT pin goes low if INTpol is high and goes high if INTpol is low.

INT Interrupt [15]

Status	Conditions	Default State		Valid State	Interrupt Function
		Cold	Warm/hot		
		1	1	0	off
sets itself to '1'	Commands in the command table in page43 (Refer to Chapter 2.8.18) are completed.			0→1	Pending
clears to '0'	'0' is written to this bit, Cold/Warm/Hot reset is being performed, or command is written to Command Register in INT auto mode			1→0	off

Read Interrupt (RI)

This is the Read interrupt bit.

RI Interrupt [7]

Status	Conditions	Default State		Valid State	Interrupt Function
		Cold	Warm/hot		
		1	0	0	off
sets itself to '1'	At the completion of a Load, Superload or LSB Page Recovery Read Operation. (0000h, 0003h or 0005h)			0→1	Pending
clears to '0'	'0' is written to this bit, Cold/Warm/Hot reset is being performed, or command is written to Command Register in INT auto mode			1→0	off

Write Interrupt (WI)

This is the Write interrupt bit.

WI Interrupt [6]

Status	Conditions	Default State		Valid State	Interrupt Function
		Cold	Warm/hot		
		0	0	0	off
sets itself to '1'	At the completion of an Program Operation (0080h and 007Fh)			0→1	Pending
clears to '0'	'0' is written to this bit, Cold/Warm/Hot reset is being performed, or command is written to Command Register in INT auto mode			1→0	off

Erase Interrupt (EI)

This is the Erase interrupt bit.

EI Interrupt [5]

Status	Conditions	Default State		Valid State	Interrupt Function
		Cold	Warm/hot		
		0	0	0	off
sets itself to '1'	At the completion of an Erase Operation (0094h and 0030h)			0→1	Pending
clears to '0'	'0' is written to this bit, Cold/Warm/Hot reset is being performed, or command is written to Command Register in INT auto mode			1→0	off

Reset Interrupt (RSTI)

This is the Reset interrupt bit.

RSTI Interrupt [4]

Status	Conditions	Default State		Valid State	Interrupt Function
		Cold	Warm/hot		
		0	1	0	off
sets itself to '1'	At the completion of an Reset Operation (00B0h, 00F0h, 00F3h or warm reset is released)			0→1	Pending
clears to '0'	'0' is written to this bit, or command is written to Command Register in INT auto mode			1→0	off

2.8.23 Start Block Address Register F24Ch (R/W)

This Read/Write register shows the NAND Flash block address in the Write Protection mode. Setting this register precedes a 'Lock Block' command, 'Unlock Block' command, or 'Lock-Tight' Command.

F24Ch, default = 0000h

15	14	13	12	11	10	9	8	7	6	5	4	3	2	1	0
Reserved(000000)						SBA									

Device	Number of Block	SBA
4Gb	1024	[9:0]

2.8.24 Start Block Address Register F24Dh (R/W)

This register is reserved for future use.

2.8.25 NAND Flash Write Protection Status Register F24Eh (R)

This Read register shows the Write Protection Status of the NAND Flash memory array. To read the write protection status, FBA(DFS and DBS also in case of DDP) has to be set before reading the register.

F24Eh, default = 0002h

15	14	13	12	11	10	9	8	7	6	5	4	3	2	1	0
Reserved(00000000000000)													US	LS	LTS

Write Protection Status Information[2:0]

Item	Bit	Definition	Description
US	2	Unlocked Status	1 = current NAND Flash block is unlocked
LS	1	Locked Status	1 = current NAND Flash block is locked Or First Block of NAND Flash Array is Locked to be OTP
LTS	0	Locked-Tight Status	1 = current NAND Flash block is locked-tight

2.8.26 ECC Status Register 1 FF00h (R)

This Read register shows the Error Correction Status. The Flex-OneNAND can correct up to 4-bit errors. ECC can be performed on the NAND Flash main and spare memory areas. The ECC status register can also show the number of errors in a sector as a result of an ECC check in during a load operation. ECC status bits are also updated during a boot loading operation.

FF00h, default = 0000h

15	14	13	12	11	10	9	8	7	6	5	4	3	2	1	0
Reserved			ER1					Reserved			ER0				

2.8.27 ECC Status Register 2 FF01h (R)

FF01h, default = 0000h

15	14	13	12	11	10	9	8	7	6	5	4	3	2	1	0
Reserved			ER3					Reserved			ER2				

2.8.28 ECC Status Register 3 FF02h (R)

FF02h, default = 0000h

15	14	13	12	11	10	9	8	7	6	5	4	3	2	1	0
Reserved			ER5					Reserved			ER4				

2.8.29 ECC Status Register 4 FF03h (R)

FF03h, default = 0000h

15	14	13	12	11	10	9	8	7	6	5	4	3	2	1	0
Reserved			ER7					Reserved			ER6				

Error Status

ER	ECC Status
00000	No Error
00001	1bit error(correctable)
00010	2bit error(correctable)
00100	3bit error(correctable)
01000	4bit error(correctable)
10000	Uncorrectable

ECC location Information

Item	Definition
ER0	Error status of 1st selected sector (Main and Spare area)
ER1	Error status of 2nd selected sector (Main and Spare area)
ER2	Error status of 3rd selected sector (Main and Spare area)
ER3	Error status of 4th selected sector (Main and Spare area)
ER4	Error status of 5th selected sector (Main and Spare area)
ER5	Error status of 6th selected sector (Main and Spare area)
ER6	Error status of 7th selected sector (Main and Spare area)
ER7	Error status of 8th selected sector (Main and Spare area)

3.0 DEVICE OPERATION

This section of the data sheet discusses the operation of the Flex-OneNAND device. It is followed by AC/DC Characteristics and Timing Diagrams which may be consulted for further information.

The Flex-OneNAND supports a limited command-based interface in addition to a register-based interface for performing operations on the device.

3.1 Command Based Operation

Flex-OneNAND supports a limited command based interface. The address range of BootRAM ([0000h - 01FFh, 8000h - 800Fh]), called the Boot Partition is actually a read only area. This is because it contains boot-loader code which must not be overwritten.

Therefore any attempt of data write to the Boot Partition is interpreted by Flex-OneNAND as a "Command based operation".

Commands can only be written with a Boot Partition address. Thus, the command-based interface is active only in the boot partition.

The remaining address range, except for the boot area, (address range [0200h - FFFFh]) can be used as a read/write data buffer.(with a few exceptions like ID registers). Writes outside the boot partition are treated as normal writes to the buffers or registers.

The command consists of one or more cycles depending on the command. After completion of the command the device starts its execution. Writing incorrect information including address and data to the boot partition or writing an improper command will terminate the previous command sequence and make the device enter the ready status.

The defined valid command sequences are stated in Command Sequences Table. Command based operations are mainly used when Flex-OneNAND is used as Booting device, and all command based operations only supports asynchronous reads and writes. With DDP, command based operation except reset is applicable only on chip1.

Command Sequences

Command Definition		Cycles	1st cycle	2nd cycle
Reset Flex-OneNAND	Add	1	BP ¹⁾	
	Data		00F0h	
Load Data into Buffer ²⁾	Add	2	BP	BP
	Data		00E0h	0000h ³⁾
Read Identification Data ⁵⁾	Add	2	BP	XXXXh ⁴⁾
	Data		0090h	Data

NOTE :

1) BP(Boot Partition) : BootRAM Area [0000h ~ 01FFh, 8000h ~ 800Fh].

2) Load Data into Buffer operation is available within a block(128KB(SLC), 256KB(MLC)) (Chip1 only in case of DDP)

3) Load 4KB unit into DataRAM0, DataRAM1. Current Start address(FPA) is automatically increased by 4KB unit after the load.

4) 0000h -> Data is Manufacturer ID (Chip1 only in case of DDP)

0001h -> Data is Device ID (Chip1 only in case of DDP)

0002h -> Current Block Write Protection Status (Chip1 only in case of DDP)

5) WE toggling can terminate 'Read Identification Data' operation.

3.1.1 Reset Flex-OneNAND Command

The Reset command is given by writing 00F0h to the boot partition address. Reset will return all default values into the device.

3.1.2 Load Data Into Buffer Command

Load Data into Buffer command is a two-cycle command. Two sequential designated command activates this operation. Sequentially writing 00E0h and 0000h to the boot partition [0000h~01FFh, 8000h~800Fh] will load one page to DataRAM0 and DataRAM1. This operation refers to FBA. FSA must be 00 and BSA must be 1000.

At the end of this operation, FPA will be automatically increased by 1. So continuous issue of this command will sequentially load data in next page to DataRAM0, DataRAM1. This page address increment is restricted within a block.

The default value of FBA and FPA is 0. Therefore, initial issue of this command after power on will load the first page of memory, which is usually boot code.

3.1.3 Read Identification Data Command

The Read Identification Data command consists of two cycles. It gives out the devices identification data according to the given address. The first cycle is 0090h to the boot partition address and second cycle is read from the addresses specified in Identification Data Description Table.

Identification Data Description

Address	Data Out
0000h	Manufacturer ID (00ECh)
0001h	Device ID ¹⁾
0002h	Current Block Write Protection Status ²⁾













NOTE :

1) Refer to Device ID Register (Chapter 2.8.3)

2) To read the write protection status, FBA has to be set before issuing this command.

3.2 Device Bus Operation

The device bus operations are shown in the table below.

Operation	\overline{CE}	\overline{OE}	\overline{WE}	ADD0~15	DQ0~15	\overline{RP}	CLK	\overline{AVD}
Standby	H	X	X	X	High-Z	H	X	X
Warm Reset	X	X	X	X	High-Z	L	X	X
Asynchronous Write	L	H	L	Add. In	Data In	H	L	X
Asynchronous Read	L	L	H	Add. In	Data Out	H	L	 or L
Load Initial Burst Read	L	H	H	Add. In	X	H		
Burst Read	L	L	H	X	Burst Data Out	H		X
Terminate Burst Read Cycle	H	X	H	X	High-Z	H	X	X
Terminate Burst Read Cycle via \overline{RP}	X	X	X	X	High-Z	L	X	X
Terminate Current Burst Read Cycle and Start New Burst Read Cycle		H	H	Add In	High-Z	H		
Load Initial Burst Write	L	H	L	Add. In	X	H		
Burst Write	L	H	X	X	Burst Data In	H		X
Terminate Burst Write Cycle	H	X	X	X	High-Z	H	X	X
Terminate Burst Write Cycle via \overline{RP}	X	X	X	X	High-Z	L	X	X
Terminate Current Burst Write Cycle and Start New Burst Write Cycle		H	L	Add In	High-Z	H		

NOTE :
 L=VIL (Low), H=VIH (High), X=Don't Care.

3.3 Reset Mode Operation

The Flex-OneNAND has 4 reset modes: Cold/Warm/Hot Reset, and NAND Flash Array Reset. Section 3.3 discusses the operation of these reset modes.

The Register Reset Table shows the which registers are affected by the various types of Reset operations.

Internal Register Reset Table

	Internal Registers	Cold Reset (Default)	Warm Reset (RP)	Hot Reset (00F3h)	Hot Reset (BP-F0h)	NAND Flash Core Reset (00F0h)
F000h	Manufacturer ID Register (R)	00ECh	00EC	00ECh		00ECh
F001h	Device ID Register (R): Flex-OneNAND	(Note 3)	N/A	N/A		N/A
F002h	Version ID Register (R)	N/A	N/A	N/A		N/A
F003h	Data Buffer size Register (R)	0800h	N/A	N/A		N/A
F004h	Boot Buffer size Register (R)	0200h	N/A	N/A		N/A
F005h	Amount of Buffers Register (R)	0201h	N/A	N/A		N/A
F006h	Technology Register (R)	0001h	N/A	N/A		N/A
F100h	Start Address1 Register (R/W): DFS, FBA	0000h	0000h	0000h		N/A
F101h	Start Address2 Register (R/W): DBS	0000h	0000h	0000h		N/A
F107h	Start Address8 Register (R/W): FPA	0000h	0000h	0000h		N/A
F200h	Start Buffer Register (R/W): BSC, BSA	0000h	0000h	0000h		N/A
F220h	Command Register (R/W)	0000h	0000h	0000h		N/A
F221h	System Configuration 1 Register (R/W)	40C0h	(Note 1a)	(Note 1a)		N/A
F240h	Controller Status Register (R) (Note 1b) (Note 4)	0000h	0000h	0000h		N/A
F241h	Interrupt Status Register (R/W)	8080h	8010h	8010h		N/A
F24Ch	Start Block Address (R/W)	0000h	0000h	N/A		N/A
F24Eh	NAND Flash Write Protection Status (R) (Note 5)	0002h	0002h	N/A		N/A
FF00h	ECC Status Register 1 (R) (Note 2)	0000h	0000h	0000h		N/A
FF01h	ECC Status Register 2 (R) (Note 2)	0000h	0000h	0000h		N/A
FF02h	ECC Status Register 3 (R) (Note 2)	0000h	0000h	0000h		N/A
FF03h	ECC Status Register 4 (R) (Note 2)	0000h	0000h	0000h		N/A

NOTE :

- 1a) RDYpol, RDYconf, INTpol, IOBE are reset by Cold reset. The other bits are reset by cold/warm/hot reset
- 1b) The other bits except OTPL and OTPBL are reset by cold/warm/hot reset.
- 2) ECC Status Register 1~4 are reset when any command is issued.
- 3) Refer to Device ID Register F001h.
- 4) Resetting during IDLE state, this is valid. But resetting during BUSY state, refer to Chapter 2.8.21.
- 5) To read NAND Flash Write Protection status, Block Address register must be written before.

3.3.1 Cold Reset Mode Operation

See Timing Diagram 6.16

At system power-up, the voltage detector in the device detects the rising edge of Vcc and releases an internal power-up reset signal. This triggers boot code loading. Bootcode loading means that the boot loader in the device copies designated sized data (1KB) from the beginning of memory into the BootRAM. This sequence is the Cold Reset of Flex-OneNAND.

The POR(Power On Reset) triggering level is typically 1.5V(@1.8V), 1.8V(@3.3V). Boot code copy operation activates 400us after POR. Therefore, the system power should reach 1.7V(@1.8V), 2.2V(@3.3V) within 400us from the POR triggering level for bootcode data to be valid.

It takes approximately 250us to copy 1KB of boot code. Upon completion of loading into the BootRAM, it is available to be read by the host. The INT pin is not available until after IOBE = 1 and IOBE bit can be changed by host.

3.3.2 Warm Reset Mode Operation

See Timing Diagrams 6.17

A Warm Reset means that the host resets the device by using the \overline{RP} pin. When the a \overline{RP} low is issued, the device logic stops all current operations and executes internal reset operation and resets current NAND Flash core operation synchronized with the falling edge of \overline{RP} .

During an Internal Reset Operation, the device initializes internal registers and makes output signals go to default status. The BufferRAM data is kept unchanged after Warm/Hot reset operations.

The device guarantees the logic reset operation in case \overline{RP} pulse is longer than tRP min(200ns). The device may reset if tRP < tRP min(200ns), but this is not guaranteed.

Warm reset will abort the current NAND Flash core operation. During a warm reset, the content of memory cells being altered is no longer valid as the data will be partially programmed or erased.

Warm reset has no effect on contents of BootRAM and DataRAM.

3.3.3 Hot Reset Mode Operation

See Timing Diagram 6.18

A Hot Reset means that the host resets the device by Reset command. The reset command can be either Command based or Register Based. Upon receiving the Reset command, the device logic stops all current operation and executes an internal reset operation and resets the current NAND Flash core operation.

During an Internal Reset Operation, the device initializes internal registers and makes output signals go to default status. The BufferRAM data is kept unchanged after Warm/Hot reset operations.

Hot reset has no effect on contents of BootRAM and DataRAM.

3.3.4 NAND Flash Core Reset Mode Operation

See Timing Diagram 6.19

The Host can reset the NAND Flash Core operation by issuing a NAND Flash Core reset command. NAND Flash core reset will abort the current NAND Flash core operation. During a NAND Flash core reset, the content of memory cells being altered is no longer valid as the data will be partially programmed or erased.

NAND Flash Core Reset has an effect on neither contents of BootRAM and DataRAM nor register values.

3.4 Write Protection Operation

The Flex-OneNAND can be write-protected to prevent re-programming or erasure of data. The areas of write-protection are the BootRAM, and the NAND Flash Array.

3.4.1 BootRAM Write Protection Operation

At system power-up, voltage detector in the device detects the rising edge of Vcc and releases the internal power-up reset signal which triggers boot code loading. And the designated size data(1KB) is copied from the first page of the first block in the NAND flash array to the BootRAM.

After the bootcode loading is completed, the BootRAM is always locked to protect the boot code from the accidental write.

3.4.2 NAND Flash Array Write Protection Operation

The device has both hardware and software write protection of the NAND Flash array.

Hardware Write Protection Operation

The hardware write protection operation is implemented by executing a Cold or Warm Reset. On power up, the NAND Flash Array is in its default, locked state. The entire NAND Flash array goes to a locked state after a Cold or Warm Reset.

Software Write Protection Operation

The software write protection operation is implemented by writing a Lock command (002Ah) or a Lock-tight command (002Ch) to command register (F220h).

Lock (002Ah) and Lock-tight (002Ch) commands write protects the block defined in the Start Block Address Register F24Ch.

3.4.3 NAND Array Write Protection States

There are three lock states in the NAND Array: unlocked, locked, and locked-tight. On power up, all blocks in the NAND array go to Locked state. The lock status is maintained for each block in the NAND array. Any changes made to lock status of blocks are lost when Cold/warm reset occurs.

Flex-OneNAND supports 4 commands for changing Write Protection states of the blocks: lock/unlock/lock-tight by one block, and All Block Unlock at once.

All Block Unlock command fails if there are lock-tight blocks in flash.

Write Protection Status

The current block Write Protection status can be read in NAND Flash Write Protection Status Register(F24Eh). There are three bits - US, LS, LTS -, which are not cleared by hot reset and NAND Flash Core Reset. These Write Protection status registers are updated when FBA is set, and when Write Protection command is entered.

The followings summarize locking status.

By default, [2:0] values are 010. For example:

- > If host executes unlock block operation, then [2:0] values turn to 100.
- > If host executes lock-tight block operation, then [2:0] values turn to 001.

3.4.3.1 Unlocked NAND Array Write Protection State

An Unlocked block can be programmed or erased. The status of an unlocked block can be changed to locked or locked-tight using the appropriate software command(Locked-tight state can be achieved in 2 steps. First, the block should be locked via the lock command. Then, Lock tight command must be issued.).

Only one block can be released from lock state to unlock state with Unlock command and addresses. The unlocked block can be changed with new lock command. Therefore, each block has its own lock/unlock/lock-tight state.

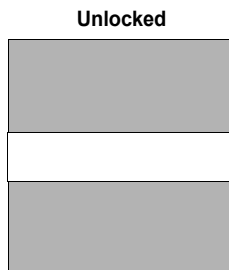

Unlock Command Sequence:
Start block address+Unlock block command (0023h)

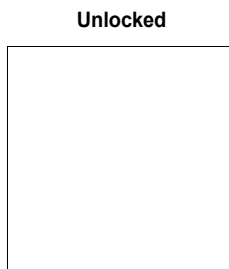

All Block Unlock Command Sequence:
Start block address(000h)+All Block Unlock command (0027h)

NOTE :
Even though SBA is fixed to 000h, Unlock will be done for all block. All block unlock is not valid if there is a lock-tight block. With DDP, all block unlock command must be issued on each chip.

3.4.3.2 Locked NAND Array Write Protection State

A Locked block cannot be programmed or erased. All blocks default to a locked state following a Cold or Warm Reset. Unlocked blocks can be changed to locked using the Lock block command. The status of a locked block can be changed to unlocked or locked-tight using the appropriate software command.

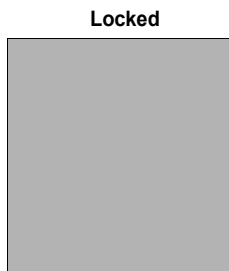

Lock Command Sequence:
Start block address+Lock block command (002Ah)

3.4.3.3 Locked-tight NAND Array Write Protection State

A block that is in a locked-tight state can only be changed to locked state after a Cold or Warm Reset. Unlock and Lock command sequences will not affect its state. This is an added level of write protection security.

A block must first be set to a locked state before it can be changed to locked-tight using the Lock-tight command. locked-tight blocks will revert to a locked state following a Cold or Warm Reset.

When there are Lock-tight blocks in the flash array, All Block Unlock Command will fail and there will be no change in the lock status of the blocks of the Flash array.

Thus, All Block Unlock command succeeds only when there are no tightly-locked blocks in Flash.

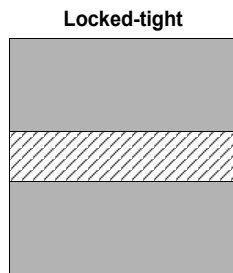

Lock-Tight Command Sequence:

Start block address+Lock-tight block command (002Ch)

3.4.4 NAND Flash Array Write Protection State Diagram

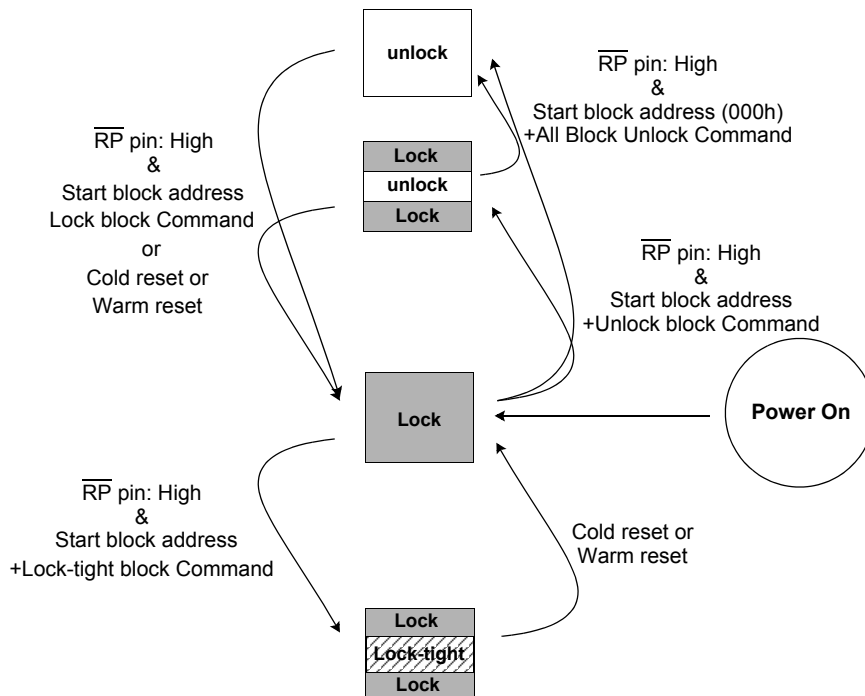

*NOTE : If the 1st Block is set to be OTP, Block 0 will always be Lock Status

Data Protection Operation Flow Diagram

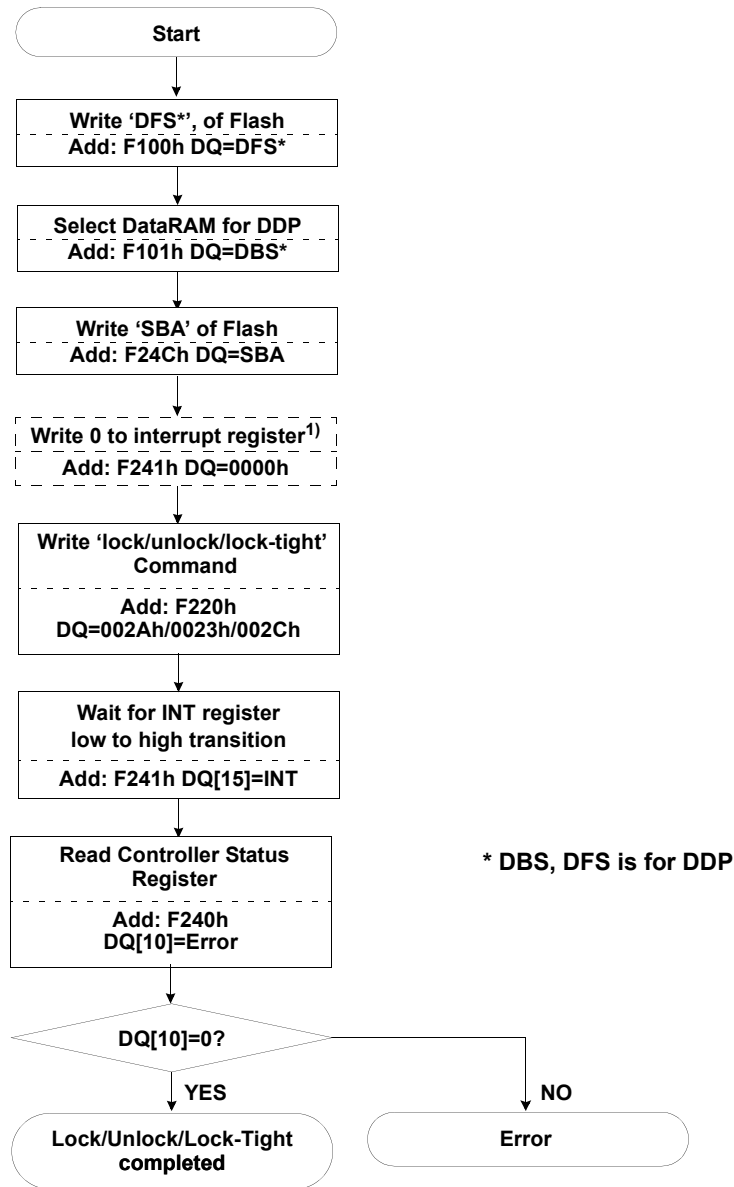

NOTE :

1) 'Write 0 to interrupt register' step may be ignored when using INT auto mode. Refer to chapter 2.8.18.1

* Samsung strongly recommends to follow the above flow chart

All Block Unlock Flow Diagram

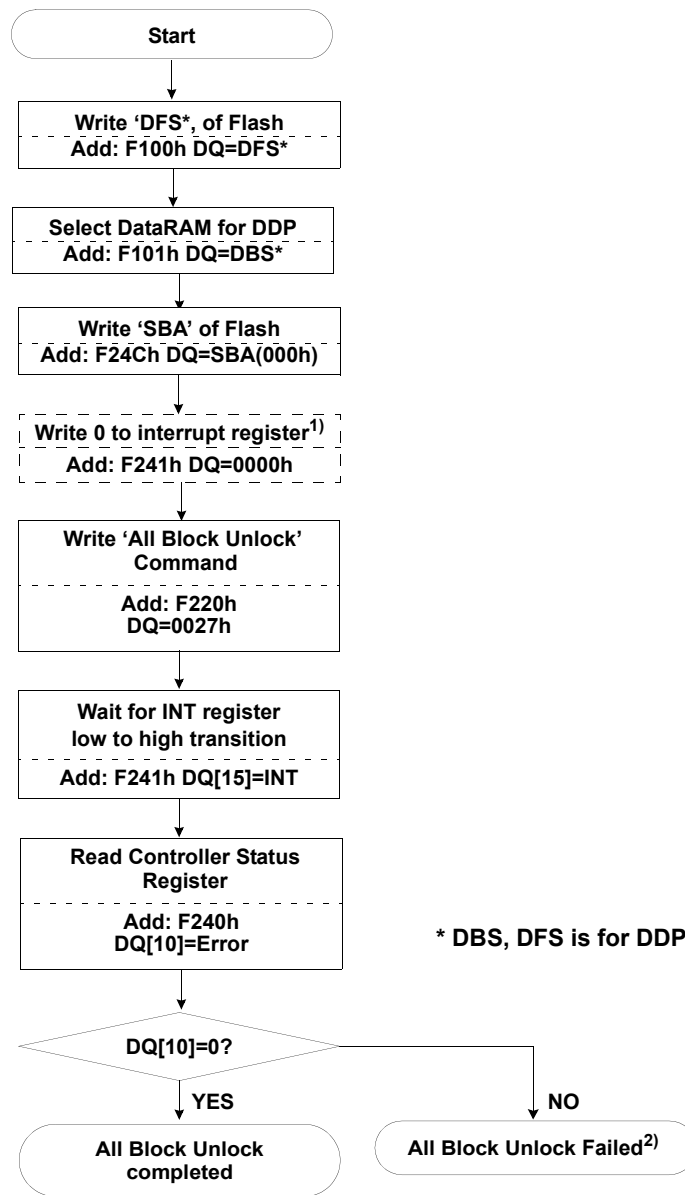

NOTE :

- 1) 'Write 0 to interrupt register' step may be ignored when using INT auto mode. Refer to chapter 2.8.18.1
- 2) All Block Unlock command fails if there are lock-tight blocks in flash.

*Samsung strongly recommends to follow the above flow chart

3.5 Data Protection During Power Down Operation

See Timing Diagram 6.20

The device is designed to offer protection from any involuntary program/erase during power-transitions. RP pin which provides hardware protection is recommended to be kept at VIL before Vcc drops to 1.5V(@1.8V), 1.8V(@3.3V).

3.6 Load Operation

See Timing Diagrams 6.10

The Load operation is initiated by setting up the start address from which the data is to be loaded. The Load command is issued in order to initiate the load.

During a Load operation, the device:

- Transfers the data from NAND Flash array into the BufferRAM
- ECC is checked and any detected and corrected error is reported in the status response as well as any unrecoverable error.

Once the BufferRAM has been filled, an interrupt is issued to the host so that the contents of the BufferRAM can be read. The read from the BufferRAM can be an asynchronous read mode or synchronous read mode. The status information related to load operation can be checked by the host if required.

Load Operation Flow Chart Diagram

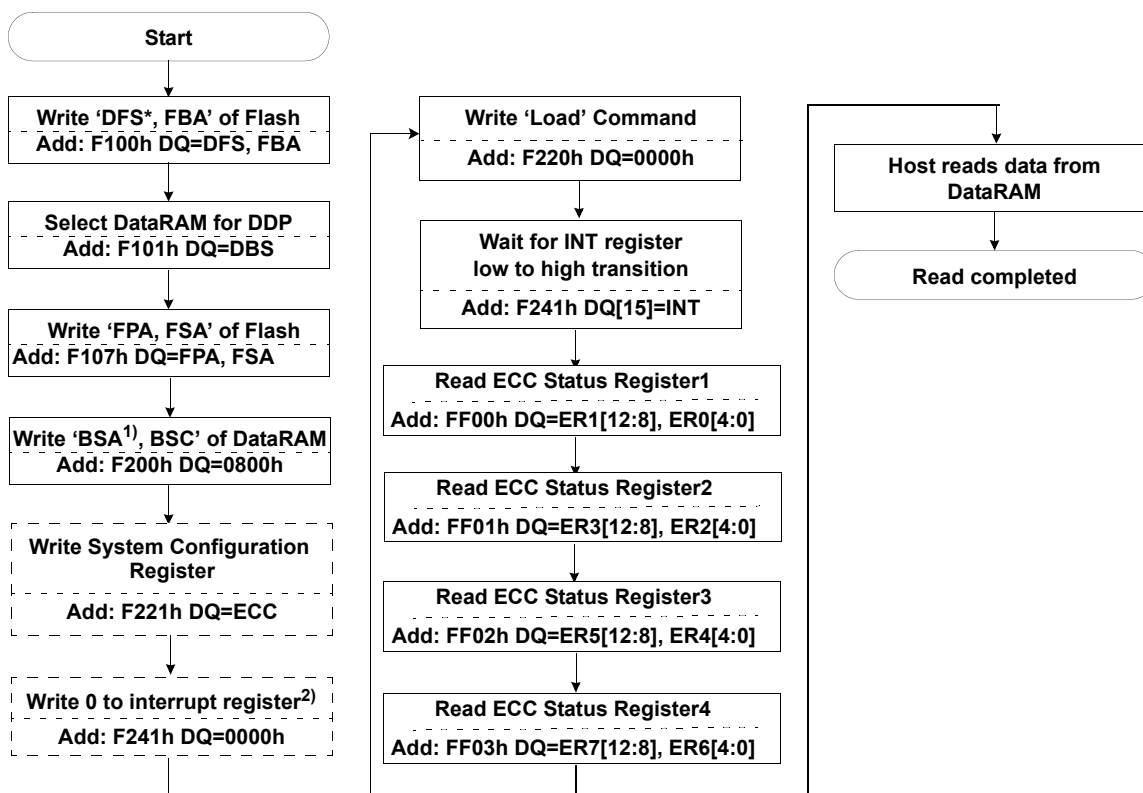

* DBS, DFS is for DDP

NOTE :

- 1) BSA must be 1000.
- 2) 'Write 0 to interrupt register' step may be ignored when using INT auto mode. Refer to chapter 2.8.18.1

3.6.1 Superload Operation

See Timing Diagrams 6.11

The Superload operation is used to read multiple pages. During Superload operation, up to 4bit errors are corrected. Once the first data is loaded, an interrupt status returns to ready. The data in DataRAM should be read after next Superload command is issued. Data is being loaded from NAND to page buffer until **whole data in DataRAM** is read. The read from the DataRAM can be only synchronous read mode. The status information related to load operation can be checked by the host if required. When host accesses DataRAM, the address of DataRAM must be a multiple of 4.

Superload operation must be utilized within a same area partitioned as SLC or MLC.

Superload Operation Flow Chart Diagram

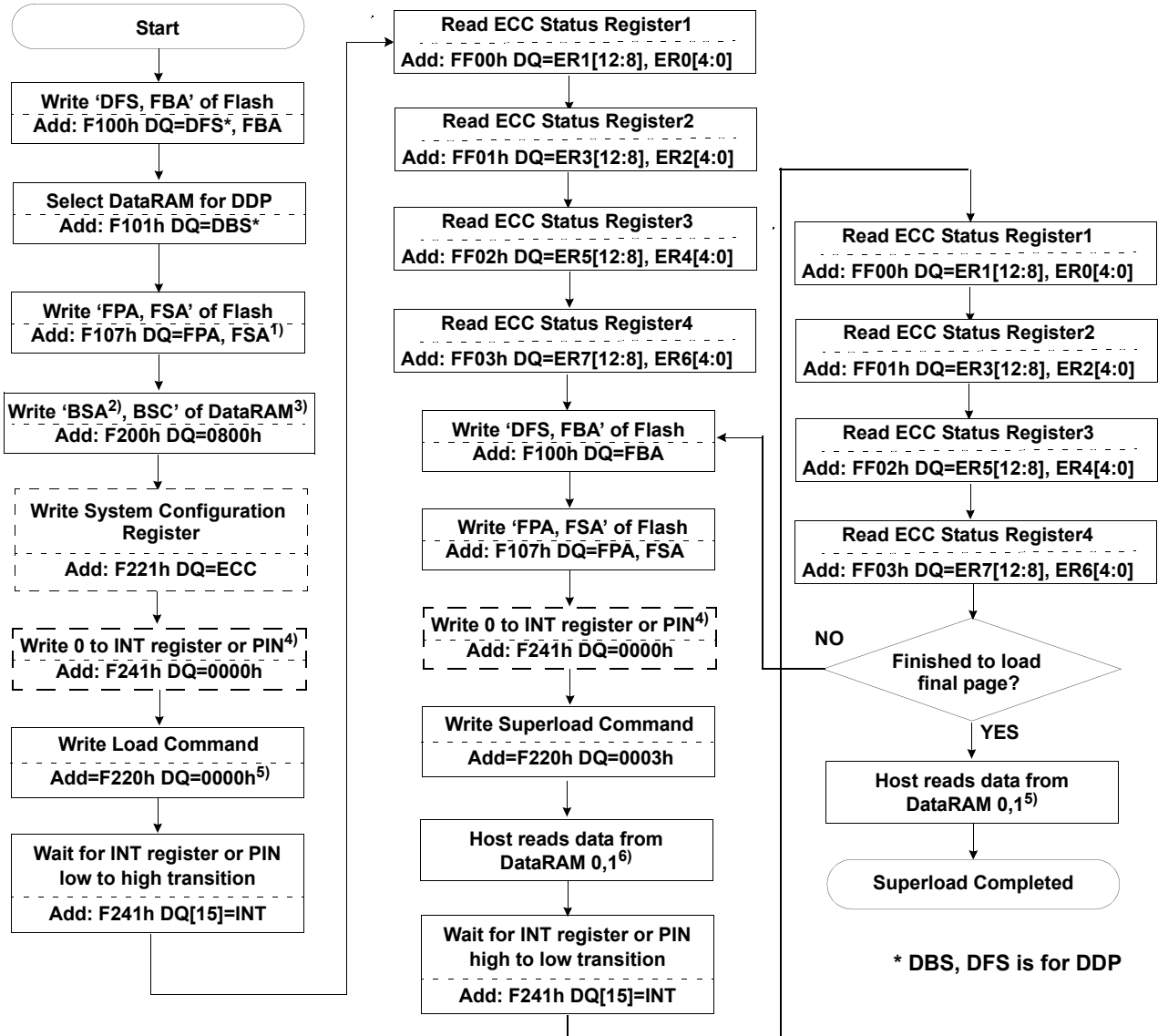

* DBS, DFS is for DDP

NOTE :

- 1) FSA must be 00 and BSC must be 000 always for Superload operation.
- 2) BSA must be 1000.
- 3) In case of Superload operation, the number of sectors to be loaded is 8 sectors.
- 4) 'Write 0 to interrupt register' step may be ignored when using INT auto mode. Refer to chapter 2.8.18
- 5) For the first load, hosts must issue 'Load(0000h)' command.
- 6) In case of Superload operation, only synchronous read mode is valid.
 Host should read data out until end of DataRAM(804FH).
 After Reading out the last data(Add:804F), Additional clock should not be asserted.

3.6.2 LSB Page Recovery Read

MLC NAND Flash cell has paired pages - LSB page and MSB page. LSB page has lower page address and MSB page has higher page address in paired pages. If power off occurs during MSB page program, the paired LSB page data can become corrupt. LSB page recovery read is a way to read LSB page though page data are corrupted. When uncorrectable error occurs as a result of LSB page read after power up, issue LSB page recovery read. Its command is '0005h'. Flow chart below shows LSB page read sequence.

LSB Page Recovery read flow chart

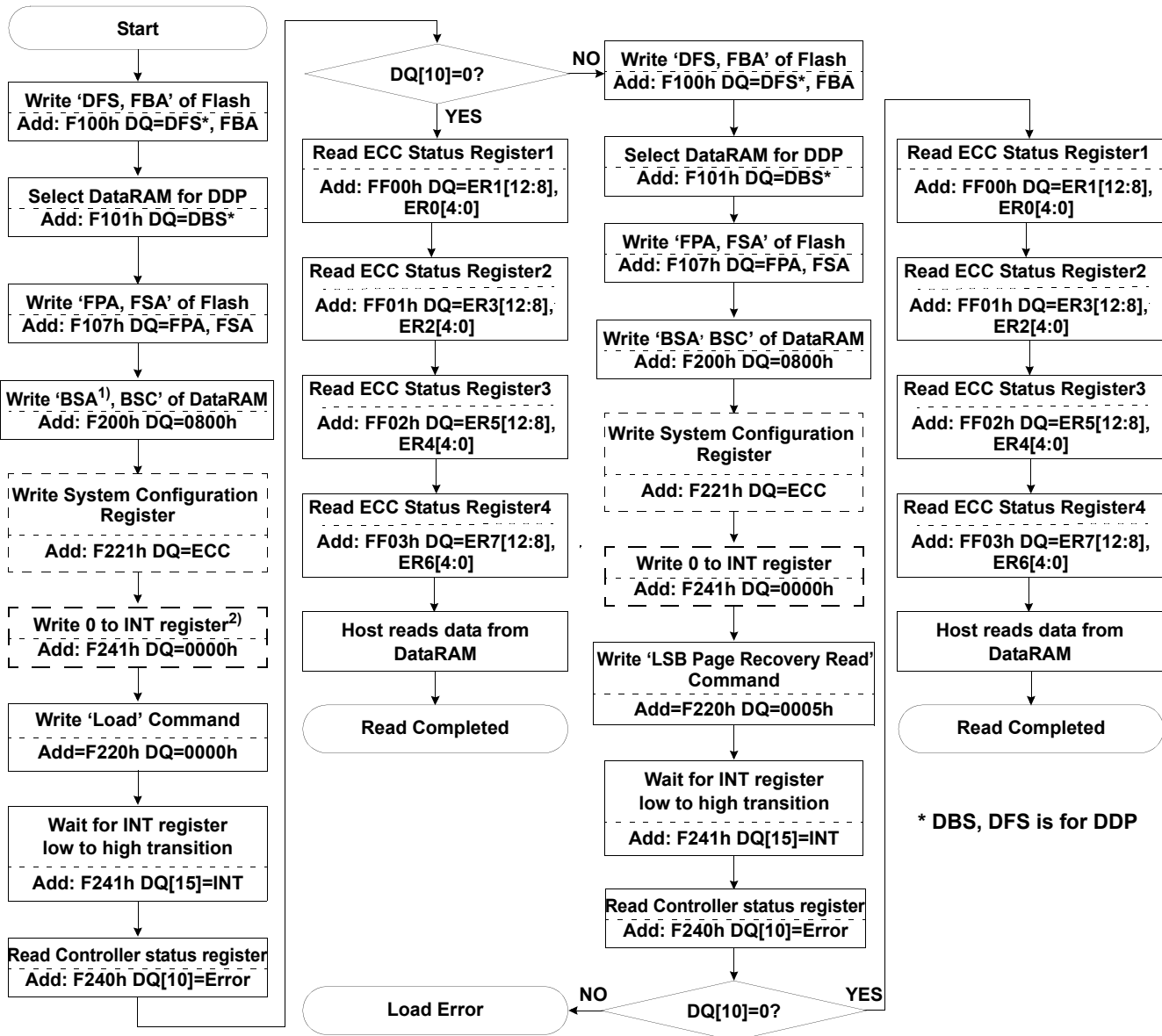

* DBS, DFS is for DDP

NOTE :

1) BSA must be 1000.

2) 'Write 0 to interrupt register' step may be ignored when using INT auto mode. Refer to chapter 2.8.18.1

3.7 Read Operation

See Timing Diagrams 6.1,6.2, 6.3 and 6.4.

The device has two read modes; Asynchronous Read and Synchronous Burst Read.

The initial state machine automatically sets the device into the Asynchronous Read Mode (RM=0) to prevent the spurious altering of memory content upon device power up or after a Hardware reset. No commands are required to retrieve data in Asynchronous Read Mode.

The Synchronous Read Mode is enabled by setting RM bit of System Configuration1 Register (F221h) to Synchronous Read Mode (RM=1). See section 2.8.19 for more information about System Configuration1 Register.

3.7.1 Asynchronous Read Mode Operation (RM=0, WM=0)

See Timing Diagrams 6.3 and 6.4

In an Asynchronous Read Mode, data is output with respect to a logic input, \overline{AVD} .

Output data will appear on DQ15-DQ0 when a valid address is asserted on A15-A0 while driving \overline{AVD} and \overline{CE} to VIL. \overline{WE} is held at VIH. The function of the \overline{AVD} signal is to latch the valid address.

Address access time from \overline{AVD} low (tAA) is equal to the delay from valid addresses to valid output data.

The Chip Enable access time (tCE) is equal to the delay from the falling edge of \overline{CE} to valid data at the outputs.

The Output Enable access time (tOE) is the delay from the falling edge of \overline{OE} to valid data at the output.

3.7.2 Synchronous Read Mode Operation (RM=1, WM=X)

See Timing Diagrams 6.1 and 6.2

In a Synchronous Read Mode, data is output with respect to a clock input.

The device is capable of a continuous linear burst operation and a fixed-length linear burst operation of a preset length. Burst address sequences for continuous and fixed-length burst operations are shown in the table below.

Burst Address Sequences

	Start Addr.	Burst Address Sequence(Decimal)				
		Continuous Burst	4-word Burst	8-word Burst	16-word Burst	32-word Burst
Wrap around	0	0-1-2-3-4-5-6...	0-1-2-3-0...	0-1-2-3-4-5-6-7-0...	0-1-2-3-4-.....-13-14-15-0...	0-1-2-3-4-.....-29-30-31-0...
	1	1-2-3-4-5-6-7...	1-2-3-0-1...	1-2-3-4-5-6-7-0-1...	1-2-3-4-5-.....-14-15-0-1...	1-2-3-4-5-.....-30-31-0-1...
	2	2-3-4-5-6-7-8...	2-3-0-1-2...	2-3-4-5-6-7-0-1-2...	2-3-4-5-6-.....-15-0-1-2...	2-3-4-5-6-.....-31-0-1-2...

In the burst mode, the initial word will be output asynchronously, regardless of BRWL. While the following words will be determined by BRWL value.

The latency is determined by the host based on the BRWL bit setting in the System Configuration 1 Register. The default BRWL is 4 latency cycles. At clock frequencies of 40MHz or lower, latency cycles can be reduced to 3. BRWL can be set up to 7 latency cycles.

The BRWL registers in System Configuration 1 Register can be read during a burst read mode by using the \overline{AVD} signal with the address F221h.

3.7.2.1 Continuous Linear Burst Read Operation

See Timing Diagram 6.2

First Clock Cycle

The initial word is output at t_{lAA} after the rising edge of the first CLK cycle. The RDY output indicates the initial word is ready to the system by pulsing high. If the device is accessed synchronously while it is set to Asynchronous Read Mode, the first data can still be read out.

Subsequent Clock Cycles

Subsequent words are output (Burst Access Time from Valid Clock to Output) t_{BA} after the rising edge of each successive clock cycle, which automatically increments the internal address counter.

Terminating Burst Read

The device will continue to output sequential burst data until the system asserts \overline{CE} high, or \overline{RP} low, wrapping around until it reaches the designated address (see section 2.7.3 for address map information). Alternately, a Cold/Warm/Hot Reset, or a \overline{WE} low pulse will terminate the burst read operation.

Synchronous Read Boundary

Division	Add.map(word order)	
BootRAM Main(0.5KW)	0000h~01FFh	Not Supported
BufferRAM0 Main(1KW)	0200h~05FFh	Not Supported
BufferRAM1 Main(1KW)	0600h~09FFh	Not Supported
Reserved Main*	0A00h~7FFFh	Not Supported
BootRAM Spare(16W)	8000H~800Fh	
BufferRAM0 Spare(32W)	8010h~802Fh	Not Supported
BufferRAM1 Spare(32W)	8030h~804Fh	
Reserved Spare*	8050h~8FFFh	
Reserved Register*	9000h~EFFFh	
Register(4KW)	F000h~FFFFh	

NOTE :

Continuous burst read should be done, with in the address range of the selected buffer RAM, dataRAM0 or DataRAM1.

* Reserved area is not available on Synchronous read

3.7.2.2 4-, 8-, 16-, 32-Word Linear Burst Read Operation

See Timing Diagram 6.1

An alternate Burst Read Mode enables a fixed number of words to be read from consecutive address.

The device supports a burst read from consecutive addresses of 4-, 8-, 16-, and 32-words with a linear-wrap around. When the last word in the burst has been reached, assert \overline{CE} and \overline{OE} high to terminate the operation.

In this mode, the start address for the burst read can be any address of the address map with one exception. The device does not support a 32-word linear burst read on the spare area of the BufferRAM.

3.7.2.3 Programmable Burst Read Latency Operation

See Timing Diagrams 6.1 and 6.2

Upon power up, the number of initial clock cycles from Valid Address (\overline{AVD}) to initial data defaults to four clocks.

The number of clock cycles (n) which are inserted after the clock which is latching the address. The host can read the first data with the (n+1)th rising edge.

The number of total initial access cycles is programmable from three to seven cycles. After the number of programmed burst clock cycles is reached, the rising edge of the next clock cycle triggers the next burst data.

Four Clock Burst Read Latency (BRWL=4 case)

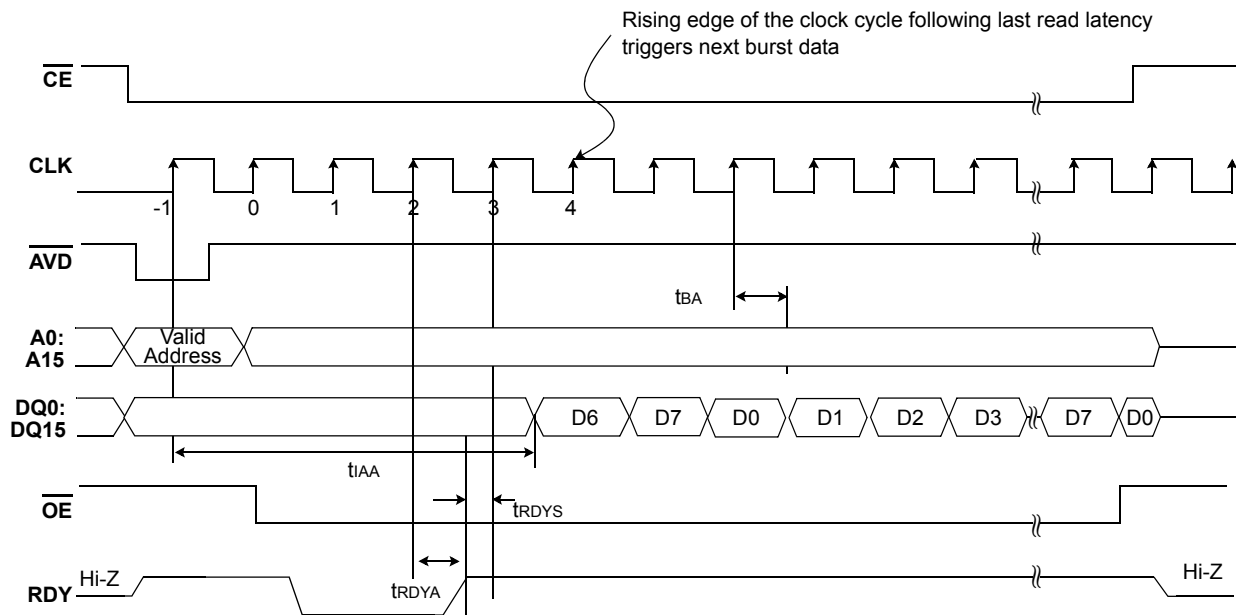

***NOTE :**
 BRWL=4, HF=0 is recommended for 40MHz~66MHz. For frequency over 66MHz, BRWL should be 6 or 7 while HF=1.
 Also, for frequency under 40MHz, BRWL can be reduced to 3, and HF=0.

3.7.3 Handshaking Operation

The handshaking feature allows the host system to simply monitor the RDY signal from the device to determine when the initial word of burst data is ready to be read.

To set the number of initial cycles for optimal burst mode, the host should use the programmable burst read latency configuration (see section 2.8.19, "System Configuration1 Register").

The rising edge of RDY which is derived at one cycle prior of data fetch clock indicates the initial word of valid burst data.

3.7.4 Output Disable Mode Operation

When the \overline{CE} or \overline{OE} input is at V_{IH} , output from the device is disabled. The outputs are placed in the high impedance state.

3.8 Synchronous Write(RM=1, WM=1) (1.8V only)

See Timing Diagram 6.7, 6.8 and 6.9

Burst mode operations enable high-speed synchronous read and write operations. Burst operations consist of a multi-clock sequence that must be performed in an ordered fashion. After \overline{CE} goes low, the address to access is latched on the next rising edge of \overline{clk} that \overline{ADV} is low. During this first clock rising edge, \overline{WE} indicates whether the operation is going to be a read (\overline{WE} = high) or write (\overline{WE} = low). The size of a burst can be specified in the BL as either a fixed length or continuous. Fixed-length bursts consist of 4, 8, 16, and 32 words. Continuous burst write has the ability to start at a specified address and burst within the designated DataRAM. The latency count stored in the BRWL defines the number of clock cycles that elapse before the initial data value is transferred between the processor and Flex-OneNAND device. The RDY output will be asserted as soon as a burst is initiated, and will be de-asserted to indicate when data is to be transferred into (or out of) the memory. The processor can access other devices without incurring the timing penalty of the initial latency for a new burst by suspending burst mode. Bursts are suspended by stopping \overline{clk} . \overline{clk} can be stopped high or low. Note that the RDY output will continue to be active, and as a result no other devices should directly share the RDY connection to the controller. To continue the burst sequence, \overline{clk} is restarted after valid data is available on the bus.

Same as the normal burst mode, the latency is determined by the host based on the BRWL bit setting in the System Configuration 1 Register. The default BRWL is 4 latency cycles. At clock frequencies of 40MHz or lower, latency cycles can be reduced to 3, at frequency range from 40MHz to 66MHz, latency cycle should be over 4. Over clock frequency of 66MHz, latency cycle should be over 6.

For BufferRAMs, both 'Start Initial Burst Write' and 'Burst Write' is supported. (Refer to Chapter 3.2) However, for Register Access, only 'Start Initial Burst Write' is supported. Therefore, Synchronous Burst Write on Register is prohibited.(Refer to Chapter 3.2 and 6.8)

3.9 Program Operation

See Timing Diagram 6.12

The Program operation is used to program data from the on-chip BufferRAMs into the NAND FLASH memory array.

The device has two 2KB data buffers, 1 Page (4KB + 128B) in size. A page has 8 sectors of 512B each main area and 16B spare area. The device can be programmed in units of 8 sectors at once.

Addressing for program operation

Within a block, the pages must be programmed consecutively from the LSB (least significant bit) page of the block to MSB (most significant bit) pages of the block. Random page address programming is prohibited. Once users start to write data on a certain page, the page is a LSB page, therefore LSB page does not have to always be a page 0.

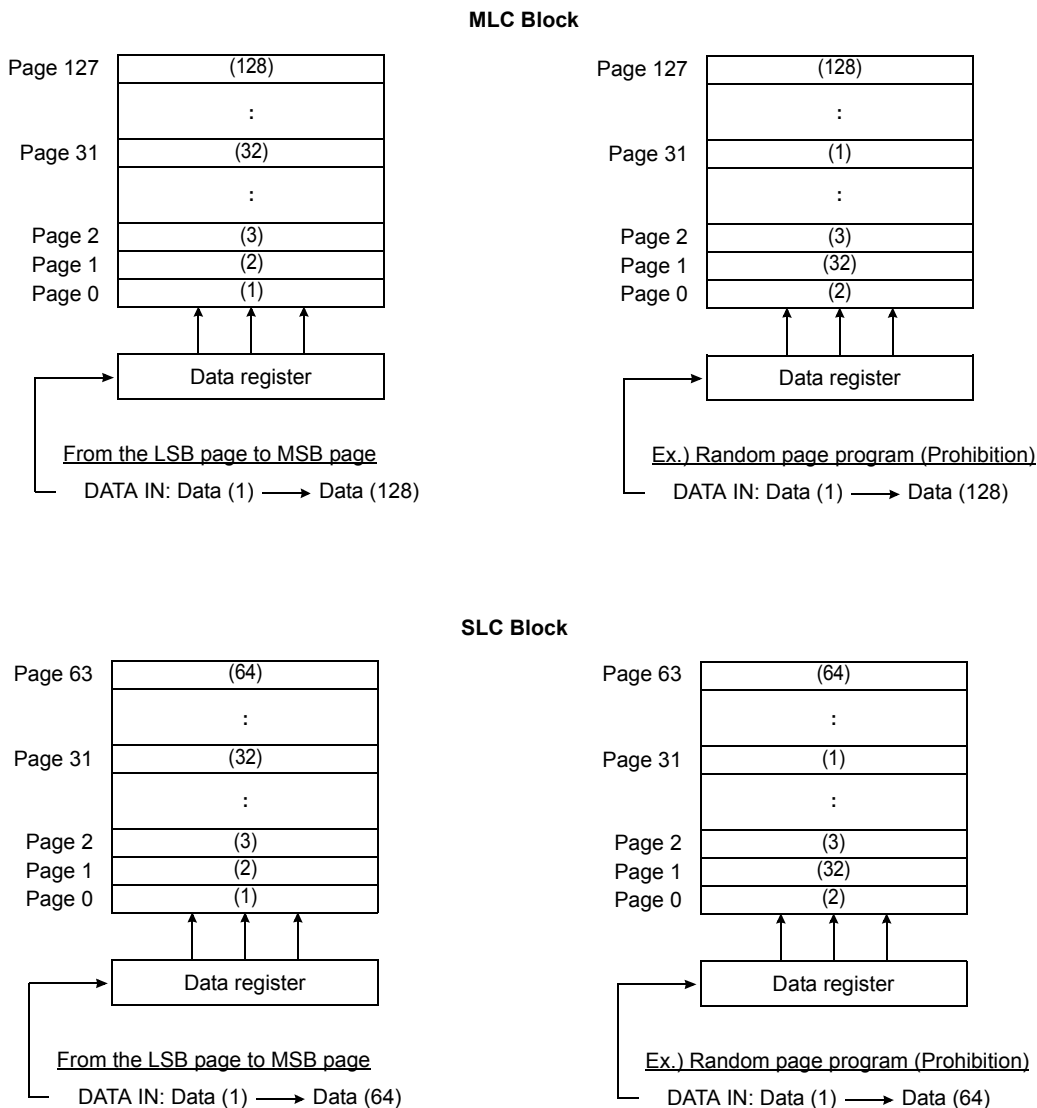

NOTE :
 The figure explains the order of page programming in a block. (x) indicates that the corresponding page is the Xth page to be written in the block.

Paired Page Address Information

In case of MLC partition, when Program, Cache Program, Interleave cache program, Copy-back with random data in operations are abnormally aborted(eg. power-down), not only page data under program but also paired page data may be damaged.

Paired Page Address		Paired Page Address	
00h	04h	01h	05h
02h	08h	03h	09h
06h	0Ch	07h	0Dh
0Ah	10h	0Bh	11h
0Eh	14h	0Fh	15h
12h	18h	13h	19h
16h	1Ch	17h	1Dh
1Ah	20h	1Bh	21h
1Eh	24h	1Fh	25h
22h	28h	23h	29h
26h	2Ch	27h	2Dh
2Ah	30h	2Bh	31h
2Eh	34h	2Fh	35h
32h	38h	33h	39h
36h	3Ch	37h	3Dh
3Ah	40h	3Bh	41h
3Eh	44h	3Fh	45h
42h	48h	43h	49h
46h	4Ch	47h	4Dh
4Ah	50h	4Bh	51h
4Eh	54h	4Fh	55h
52h	58h	53h	59h
56h	5Ch	57h	5Dh
5Ah	60h	5Bh	61h
5Eh	64h	5Fh	65h
62h	68h	63h	69h
66h	6Ch	67h	6Dh
6Ah	70h	6Bh	71h
6Eh	74h	6Fh	75h
72h	78h	73h	79h
76h	7Ch	77h	7Dh
7Ah	7Eh	7Bh	7Fh

Pairing of pages in MLC block:

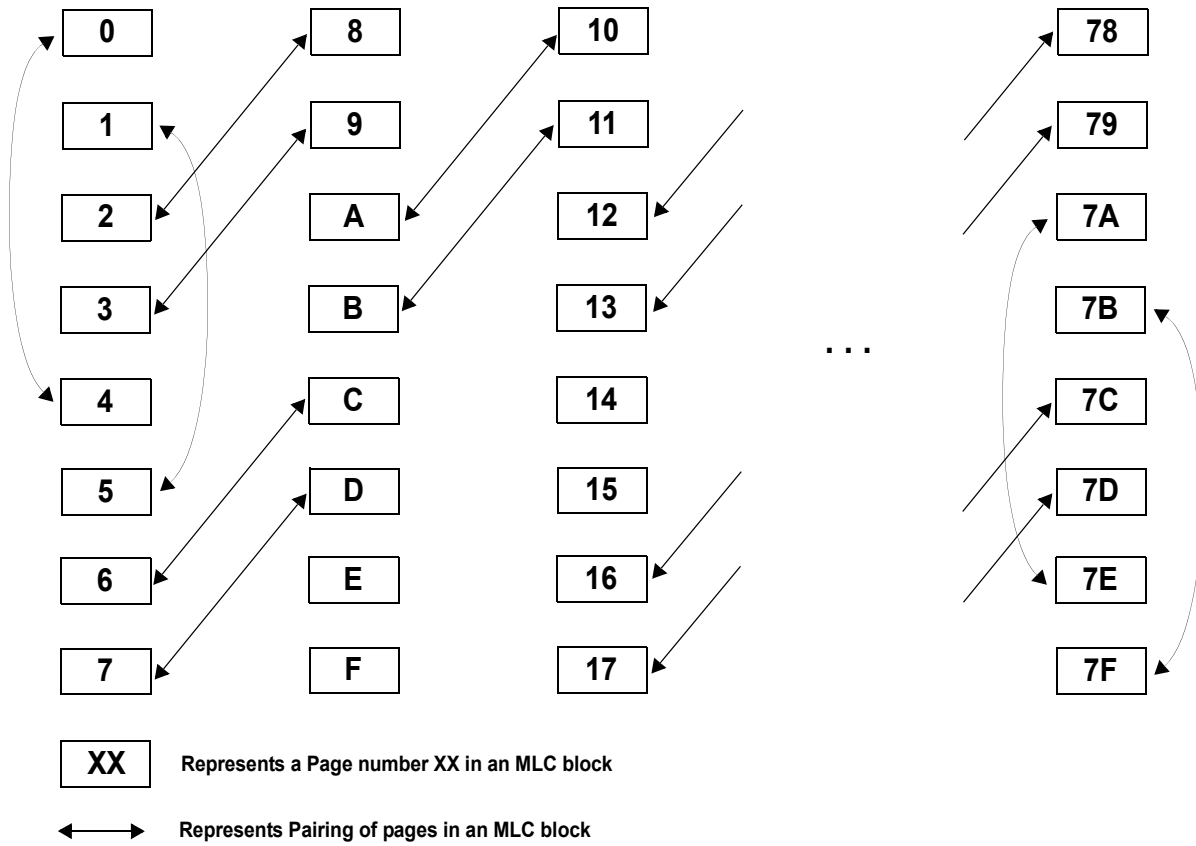

Program Operation Flow Diagram

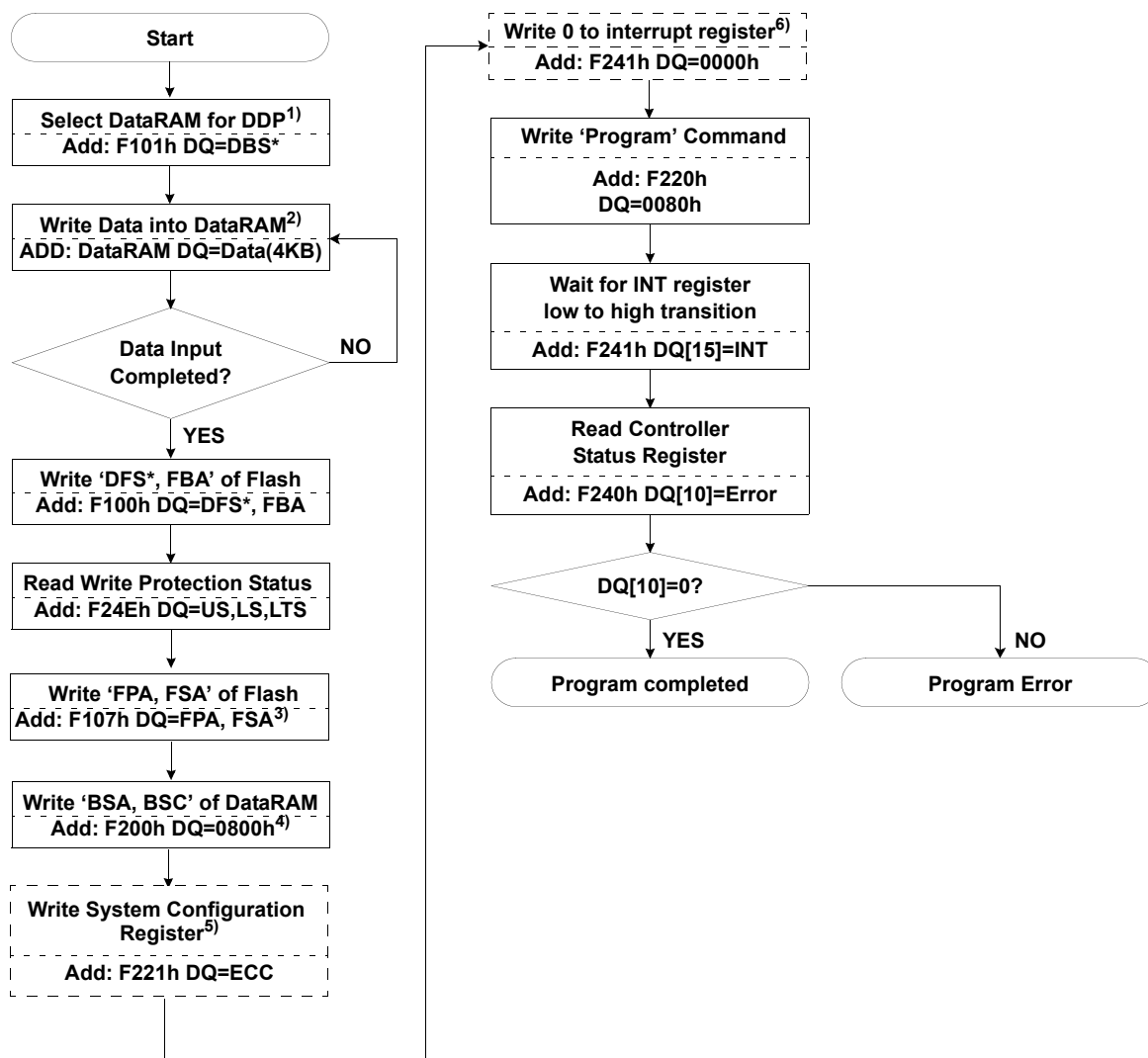

* DBS, DFS is for DDP

* : If program operation results in an error, map out the block including the page in error and copy the target data to another block.

NOTE :

- 1) DBS must be set before data input.
- 2) Data input could be done anywhere between "Start" and "Write Program Command".
- 3) FSA must be 00 within program operation.
- 4) BSA must be 1000 and BSC must be 000.
- 5) Writing System Configuration Register is optional.
- 6) 'Write 0 to interrupt register' step may be ignored when using INT auto mode. Refer to chapter 2.8.18.1

During the execution of the Internal Program Routine, the host is not required to provide any further controls or timings. Furthermore, all commands, except a Reset command, will be ignored. A reset during a program operation will cause data corruption at the corresponding location.

If a program error is detected at the completion of the Internal Program Routine, map out the block, including the page in error, and copy the target data to another block. An error is signaled if DQ10 = "1" of Controller Status Register(F240h).

If Power off occurs during a Program operation, the page that is being programmed might be corrupted. Data from paired pages may be affected.

Program Interleave(@DDP) Flow Chart

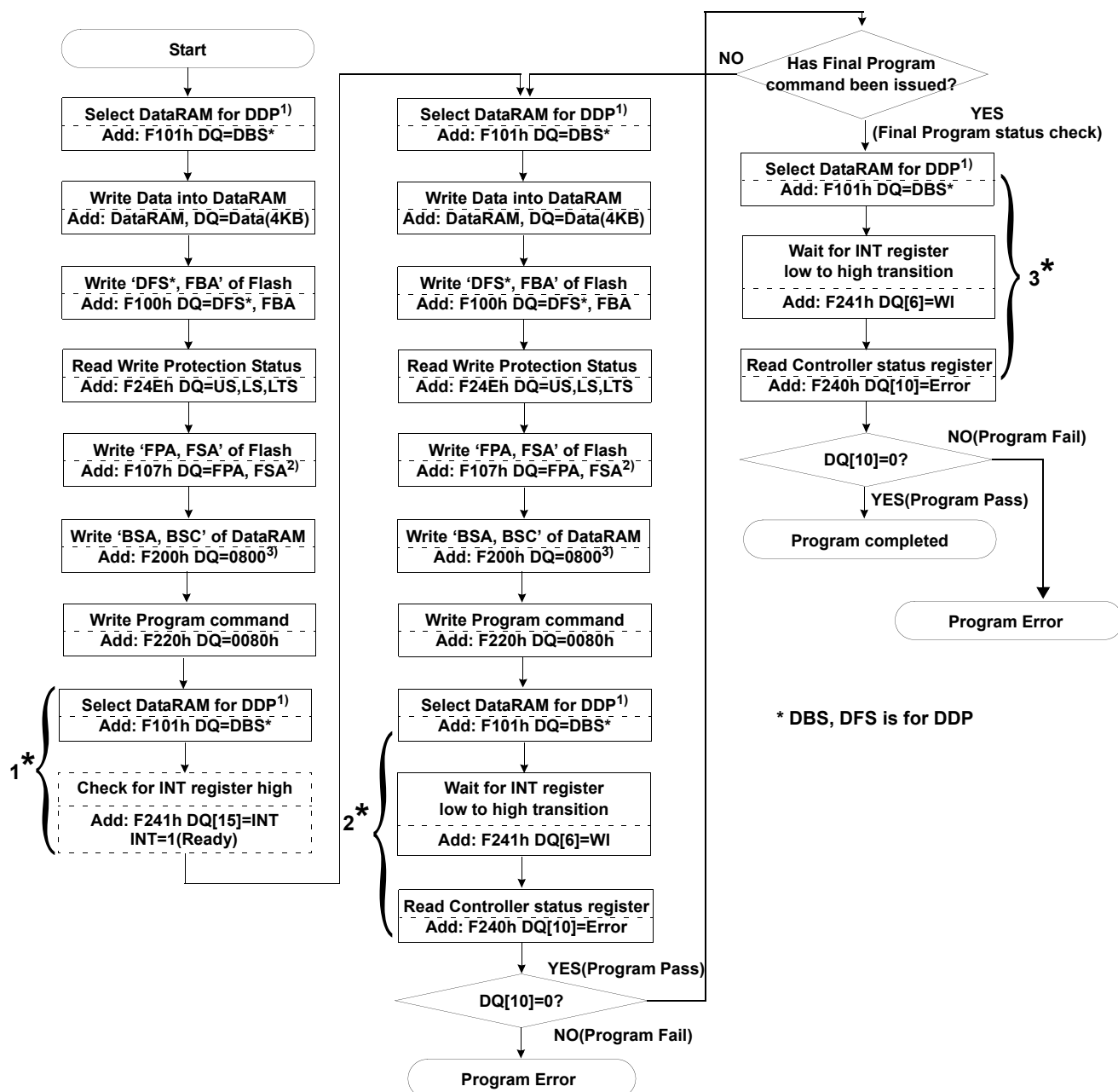

* DBS, DFS is for DDP

1* Check the chip status before command issues.

2* Previous Program Status Check
 DBS must be changed to indicate chip. Program has been issued prior to current program ongoing

3* Final Program Status Check

* Program Interleave can work in Auto INT Mode.
 Interrupt register must not be written.

NOTE :

- 1) DBS must be set before data input.
- 2) FSA must be 00 and BSC must be 000 within program operation
- 3) BSA must be 1000 and BSC must be 000.

3.9.1 Cache Program Operation

See Timing Diagram 6.13

The Cache Program is to enhance the performance of Program Operation. Employing Cache Program operation, transfer time from Host to DataRAM can be shadowed, therefore write performance will increase.

In Cache Program, since 4KB data is to be programmed into NAND Flash Array in another advanced way.

1. 4KB Data write from host to DataRAMs.
2. Cache Program command issue. This will turn INT pin to busy state¹⁾, OnGo bit sets to '1'.
(Note that before issuing 'Cache Program Command', host should make sure that the target blocks are unlocked.)
3. 4KB data will be sequentially transferred to a page buffer in NAND Flash Array.
4. When this transfer operation is complete, programming into NAND Flash Array will automatically start, and at the same time, INT bit will turn to '1' to indicate that DataRAMs are now ready to be written with next 4KB data.
5. When second 4KB is written to two DataRAMs, another Cache Program command is issued and INT bit will go to '0'¹⁾.

If host wants to program data less than 8 sectors, unwanted area to be programmed must be written to all '1's.

When INT bit goes to '1' after second data transfer from DataRAMs to Page Buffers are complete, user may check the Status Register to check the Cache program status. During Cache Program, Error bit shows the status of previous program operation.

For the final 4KB program of Cache Program scheme, host should issue Program Command(0080h). And when the final page is programmed, INT bit will turn to '1' and OnGo status bit - which indicates the overall Cache Program ongoing status - will go to '0'. At the completion of Cache Program operation, Error bit will show the pass/fail status overall status of program, and previous ~ current bit will show where the error occurred accordingly (Refer to the below diagram.)

Note that Cache Program command cannot be performed on OTP block and 1st block OTP.
 Cache Program operation must be utilized within a same area partitioned as SLC or MLC.

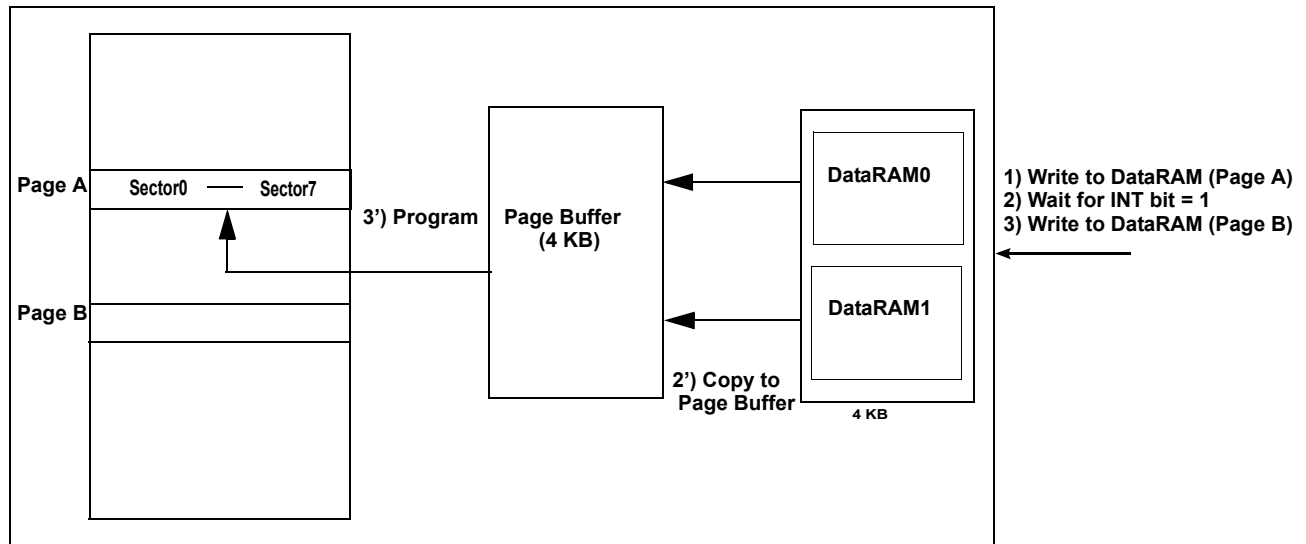

NOTE :
 2 and 2' are concurrent; 3 and 3' are concurrent.

Cache Program Operation Flow Diagram

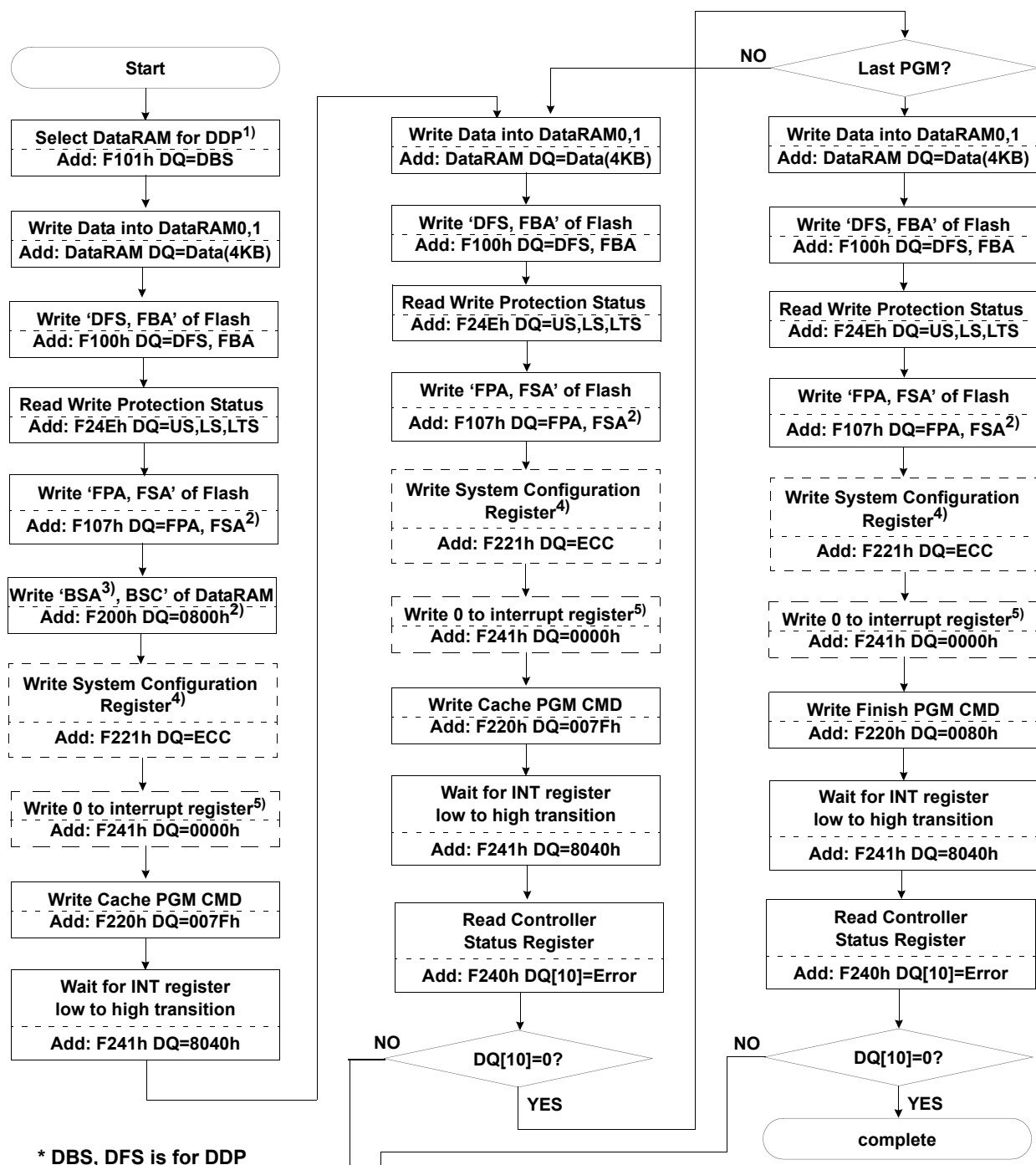

* DBS, DFS is for DDP

⊛ : If program operation results in an error, map out the block including the page in error and copy the target data to another block.

NOTE :

- 1) DBS must be set before data input.
- 2) FSA must be 00 and BSC must be 000 within program operation.
- 3) BSA must be 1000.
- 4) Writing System Configuration Register is optional.
- 5) 'Write 0 to interrupt register' step may be ignored when using INT auto mode. Refer to chapter 2.8.18.1.

3.9.2 Interleave Cache Program Operation (1.8V only)

The Interleave Cache Program is available only on DDP. Host can write data on a chip while programming another chip with this operation.

Interleave Cache Program is executing as following:

1. 4KB Data are written from host to DataRAMs in Chip1.
2. Cache Program command issue. This will turn INT bit to busy state¹⁾, OnGo bit sets to '1'.
 (Note that before issuing 'Interleave Cache Program Command', host should make sure that the target blocks are unlocked.)
3. 4KB data will be sequentially transferred to each page buffer in NAND Flash Array.
4. While these data are transferring, Host can write another 4KB Data to DataRAM in Chip2.
5. When the transfer operation is completed, programming into NAND Flash Array will automatically start, and at the same time, INT bit will turn to '1' to indicate that DataRAMs are now ready to be written with next 4KB data.
6. Second 4KB is writable on Chip1 when INT1 goes to '1'.
7. When second 4KB is written to two DataRAMs of Chip1, another Cache Program command is issued and INT1 bit will go to '0'¹⁾ again.

When INT bit goes to '1' after second data transfer from DataRAMs to Page Buffers are complete, user may check the Status Register to check the Cache program status. During Cache Program, previous bit shows the status of previous program operation.

For the final 4KB program of Interleave Cache Program scheme, host should issue Program Command(0080h) on each chip. If host issues 0080h on only a chip, another chip will be on operation as it is not finished. Ongo status bit will show the ongoing status of each chip. Its operation is same as Cache Program operation on each chip. Error bit will show the pass/fail status of each chip of Interleave Cache program, and previous ~ current bit will show where the error occurred accordingly .

Note that OTP block and 1st block OTP cannot be Interleave Cache Programmed.

Interleave Cache Program operation must be utilized within a same area partitioned as SLC or MLC.

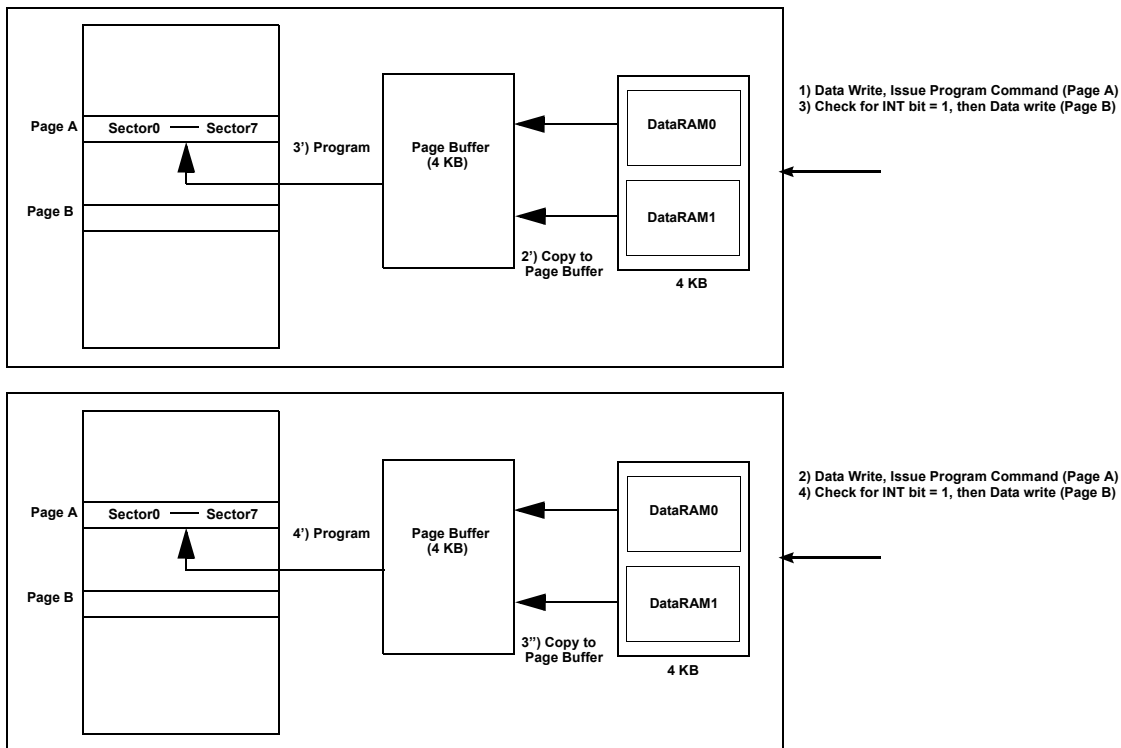

NOTE : 2 and 2' are concurrent; 3, 3'and 3'' are concurrent; 4 and 4' are concurrent

Interleave Cache Program Operation Flow Diagram

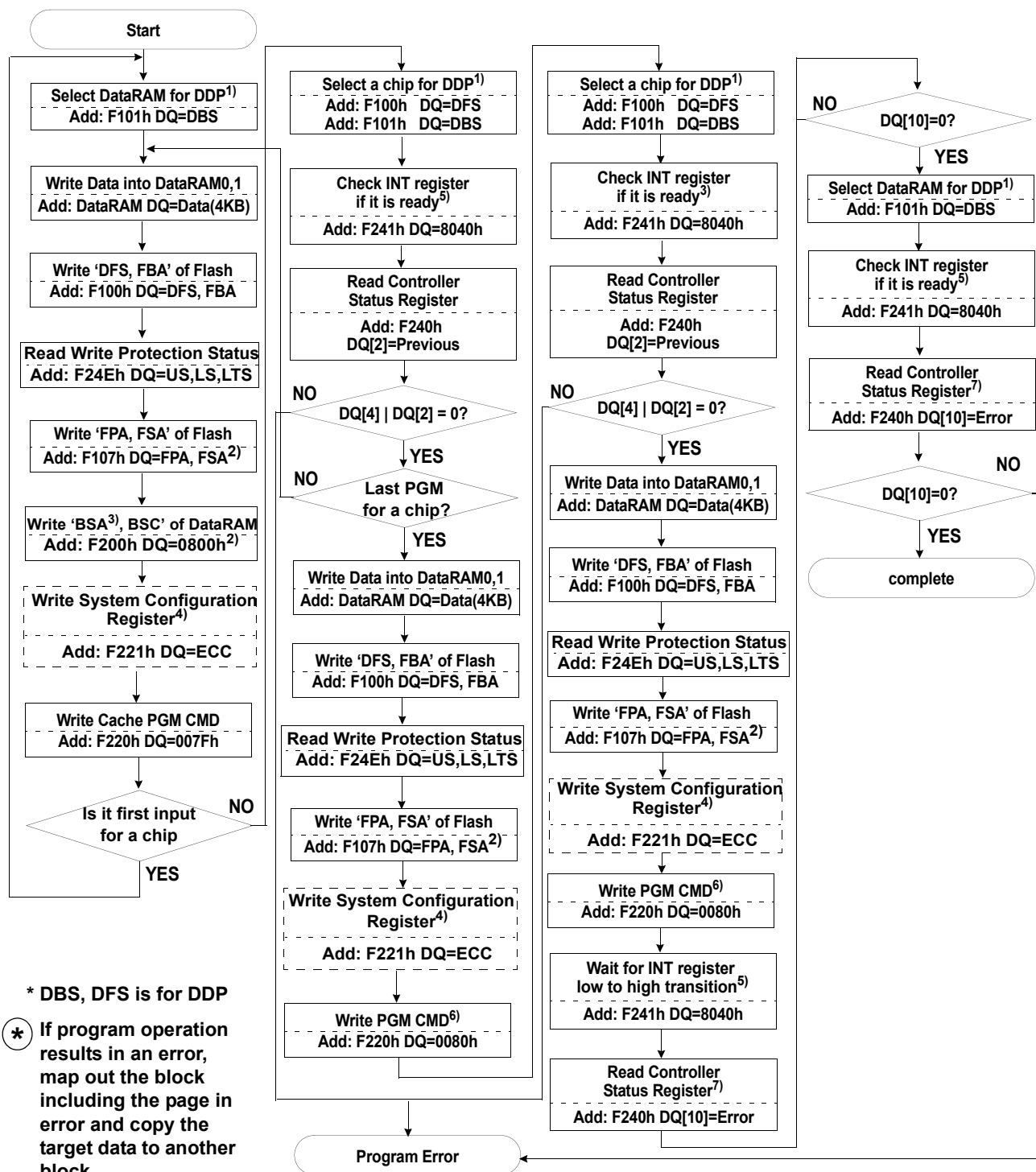

* DBS, DFS is for DDP

* If program operation results in an error, map out the block including the page in error and copy the target data to another block.

NOTE :

- 1) DBS must be set before data input.
- 2) FSA must be 00 and BSC must be 000 within program operation.
- 3) BSA must be 1000.
- 4) Writing System Configuration Register is optional.
- 5) Host is strongly recommended to see the INT register(F241h) of each chip.
- 6) Once 'PGM command' is issued onto a chip, the same command(PGM) must be issued onto another chip. If not, Samsung can not guarantee the following operation.
- 7) If error bit is set at this step, DQ[1]~[4] should be checked in order to find where the error occurred.

3.10 Copy-Back Program Operation with Random Data Input

The Copy-Back Program Operation with Random Data Input in Flex-OneNAND consists of 3 phases, Load data into DataRAM, Modify data and program into designated page. Data from the source page is saved in one of the on-chip DataRAM buffers and modified by the host, then programmed into the destination page.

As shown in the flow chart, data modification is possible upon completion of load operation. ECC is also available at the end of load operation. Therefore, using hardware ECC of Flex-OneNAND, accumulation of 4 bit error can be avoided.

Copy-Back Program Operation with Random Data Input will be effectively utilized at modifying certain bit, byte, word, or sector of source page to destination page while it is being copied.

Copy-Back Program Operation with Random Data Input Flow Chart

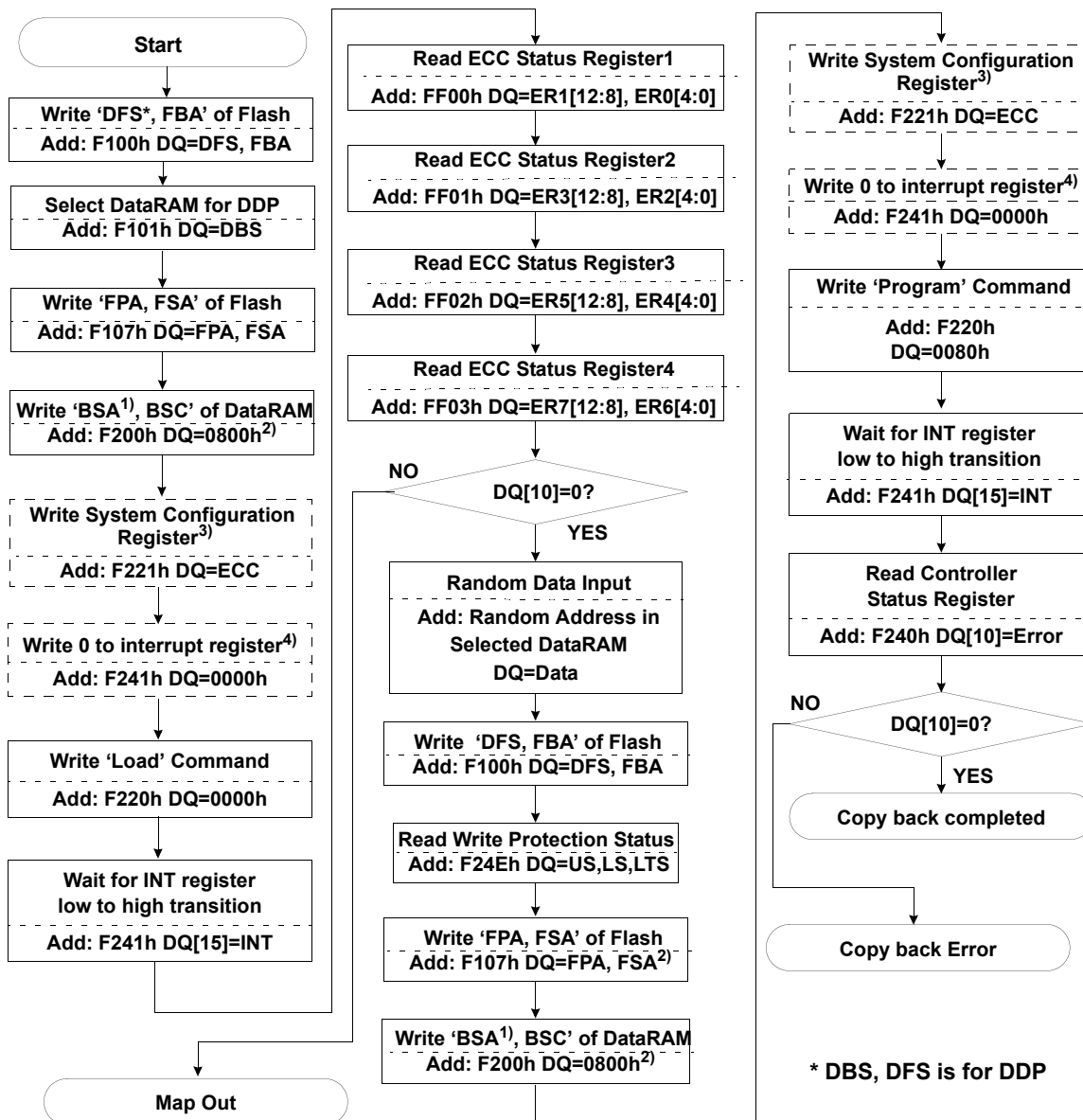

NOTE :

- 1) BSA must be 1000.
- 2) FSA must be 00 and BSC must be 000 within program operation.
- 3) Writing System Configuration Register is optional.
- 4) 'Write 0 to interrupt register' step may be ignored when using INT auto mode. Refer to chapter 2.8.18.1

* DBS, DFS is for DDP

3.11 Erase Operation

3.11.1 Block Erase Operation

See Timing Diagram 6.15

The device can be erased one block at a time. To erase a block is to write all 1's into the desired memory block by executing the Internal Erase Routine. All previous data is lost.

Block Erase Operation Flow Chart

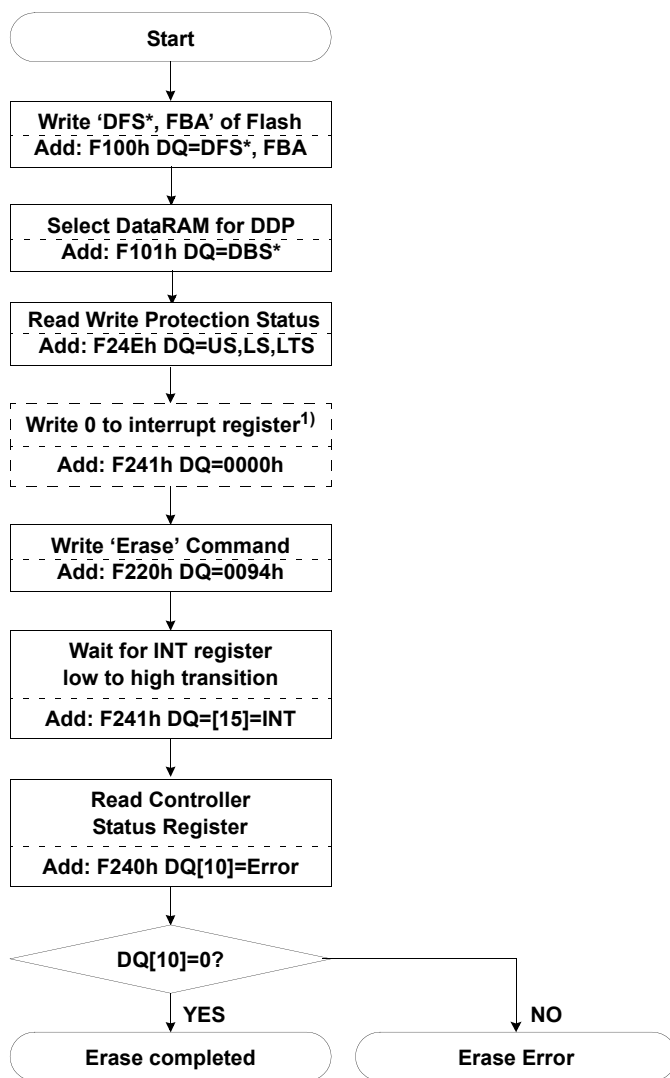

* DBS, DFS is for DDP

* : If erase operation results in an error, map out the failing block and replace it with another block.

NOTE :

1) 'Write 0 to interrupt register' step may be ignored when using INT auto mode. Refer to chapter 2.8.18.1

In order to perform the Internal Erase Routine, the following command sequence is necessary.

- The Host selects Flash Core of DDP chip.
- The Host sets the block address of the memory location.
- The Erase Command initiates the Internal Erase Routine. During the execution of the Routine, the host is not required to provide further controls or timings. During the Internal erase routine, all commands, except the Reset command and Erase Suspend Command, written to the device will be ignored.

A reset or power off during an erase operation will cause data corruption at the corresponding location Block.

Erase Interleave¹⁾ (@DDP) Flow Chart

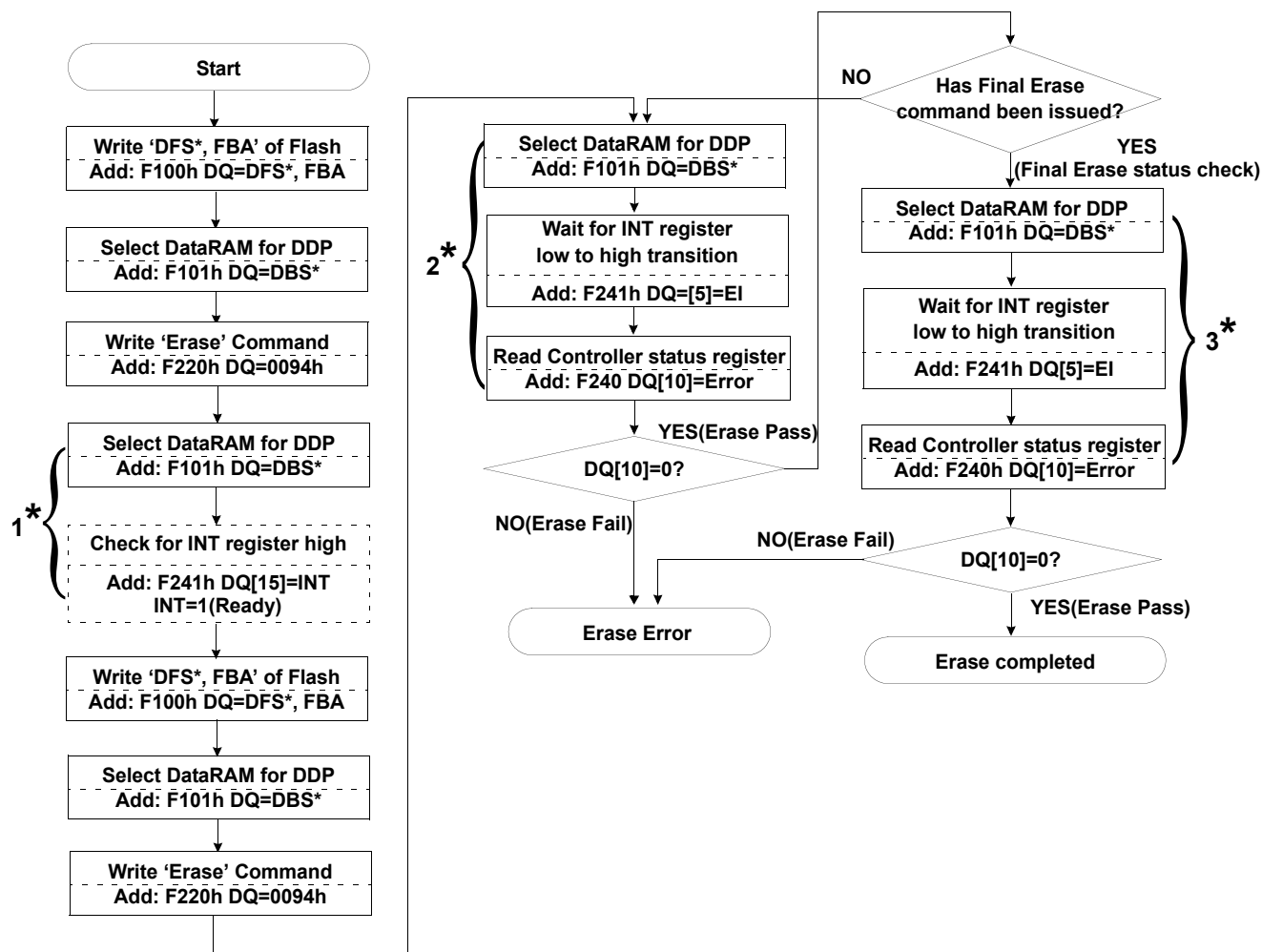

* Erase Interleave can work in Auto INT Mode.
 Interrupt register must not be written.

1* Check the chip status before command issues.

2* Previous Erase Status Check
 DBS must be changed to indicate chip. Erase has been issued prior to current erase ongoing

3* Final Erase Status Check

NOTE :

1) Erase Suspend and Erase Resume Operations are not supported in Erase Interleave(@DDP).

3.11.2 Erase Suspend / Erase Resume Operation

The Erase Suspend/Erase Resume Commands interrupt and restart a Block Erase operation so that user may perform another urgent operation on the block that is not being designated by Erase Operation.

Erase Suspend During a Block Erase Operation

When Erase Suspend command is written during a Block Erase operation, the device requires a maximum of 500us to suspend erase operation. Erase Suspend Command issue during Block Address latch sequence is prohibited.

After the erase operation has been suspended, the device is ready for the next operation including a load, program, Lock, Unlock, Lock-tight, Hot Reset, NAND Flash Core Reset, Command Based Reset, or OTP Access.

The subsequent operation can be to any block that was NOT being erased.

A special case arises in Erase Suspend operation pertaining to the OTP. A Reset command is used to exit from the OTP Access mode. If the Reset-triggered exit from the OTP Access Mode happens after an Erase Suspend Operation, the erase routine could fail. Therefore to exit from the OTP Access Mode without causing the erase suspend/resume operation to fail, a 'NAND Flash Core Reset' command should be issued.

For the duration of the Erase Suspend period the following commands are not accepted:

- Block Erase/Erase Suspend

Erase Suspend and Erase Resume Operation Flow Chart

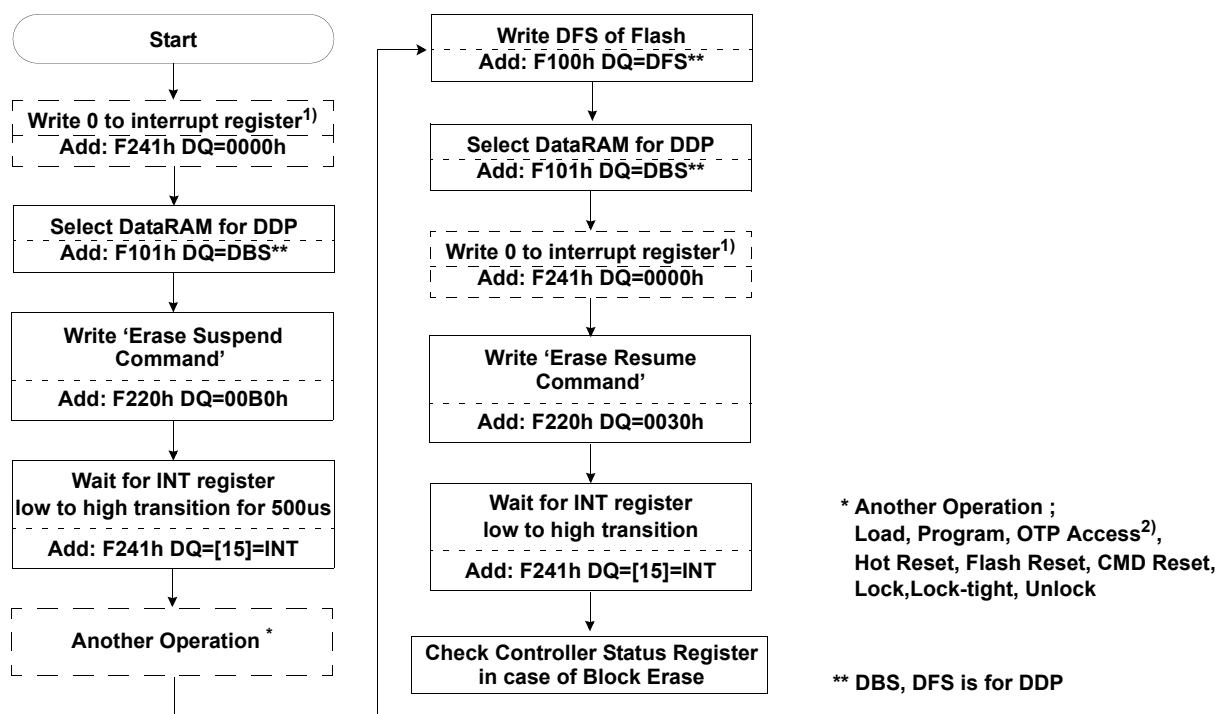

NOTE :

- 1) 'Write 0 to interrupt register' step may be ignored when using INT auto mode. Refer to chapter 2.8.18.1
- 2) If OTP access mode exit happens with Reset operation during Erase Suspend mode, Reset operation could hurt the erase operation. So if a user wants to exit from OTP access mode without the erase operation stop, Reset NAND Flash Core command should be used.

Erase Resume

When the Erase Resume command is executed, the Block Erase will restart. The Erase Resume operation does not actually resume the erase, but starts it again from the beginning.

When an Erase Suspend or Erase Resume command is executed, the addresses are in Don't Care state.

3.12 Partition Information (PI) Block (SLC Only)

One Block of the SLC NAND Flash Array memory is reserved for Partition Information (PI) Block.

The block can be read, programmed and erased using the same operations as any other NAND Flash Array memory block. Only Load, Erase and Program can be performed. PI Block is not able to cover with internal ECC Engine in OneNAND, so it has to be accessed under ECC off mode.

PI block is guaranteed to be a valid block up to 1K program/erase cycles.

Entering the PI Block

The PI block is separately accessible from the rest of the NAND Flash Array by using the PI Access command instead of the Flash Block Address (FBA).

Exiting the PI Block

To exit the PI Access Mode, a Cold-, Warm-, Hot-, or NAND Flash Core Reset operation is performed.

Exiting the PI Block during an Erase Operation

If the Reset-triggered exit from the PI Access Mode happens after during an Erase Suspend Operation, the erase routine could fail. Therefore to exit from the PI Access Mode without causing the erase operation to fail, a 'NAND Flash Core Reset' command should be issued.

PI Block Page Allocation Information

This is located at the 1st word of sector0 of page0 of main area in the Block.

The allocated word in 1st page is programmed with data FC00h initially after shipment, whole block is set as MLC except Block 0.

15	14	13	12	11	10	9	8	7	6	5	4	3	2	1	0
Lock		Reserved(1111)				Boundary Address (end of SLC area)									

PI Lock bits and Boundary Address.

PI Block can be locked only by programming lock bits into [15:14] of the 1st word of sector0, page0 of the main memory area of PI.

The first block is a SLC block. The MLC block will be defined from the next block of the block designated by boundary address programmed into[9:0] of the 1st word of sector0, page0 of the main memory area of PI.

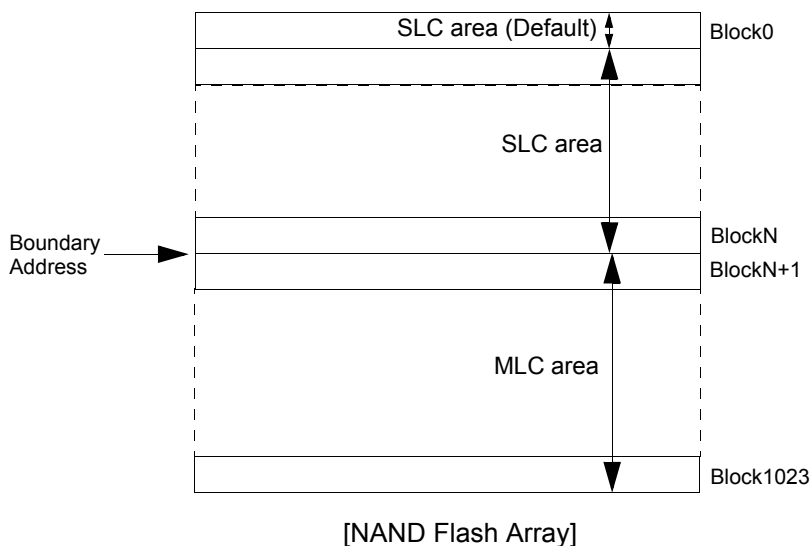

3.12.1 PI Block Boundary Information setting

It is 1st word of sector0 of page0 of main area of PI Block. The Lock bits for PI Block and Boundary address of SLC and MLC are stored. After shipment, it is initially programmed as data FC00h(Lock bit[15:14]: 11b(binary), Boundary address[9:0]: 000h). To change PI Block contents (i.e, lock bits and boundary address), Erase/Program sequence should be followed as below.

PI Block Boundary Information setting steps

- Enter PI Block access mode(Refer to Chapter 3.12.1.1).
- Issue PI Block erase(Refer to Chapter 3.12.1.2).
- Issue PI program(Refer to Chapter 3.12.1.3).
- Exit PI Block Access mode & Update new Partition Information.

PI block Access mode exit can be done through a Warm/Cold/Hot/NAND Flash Reset. However, PI Update can only be done by two methods: PI Update Command and Cold Reset. The following flow chart shows two methods for updating the PI and exiting PI access mode.

PI Block Boundary Information setting Flow Chart

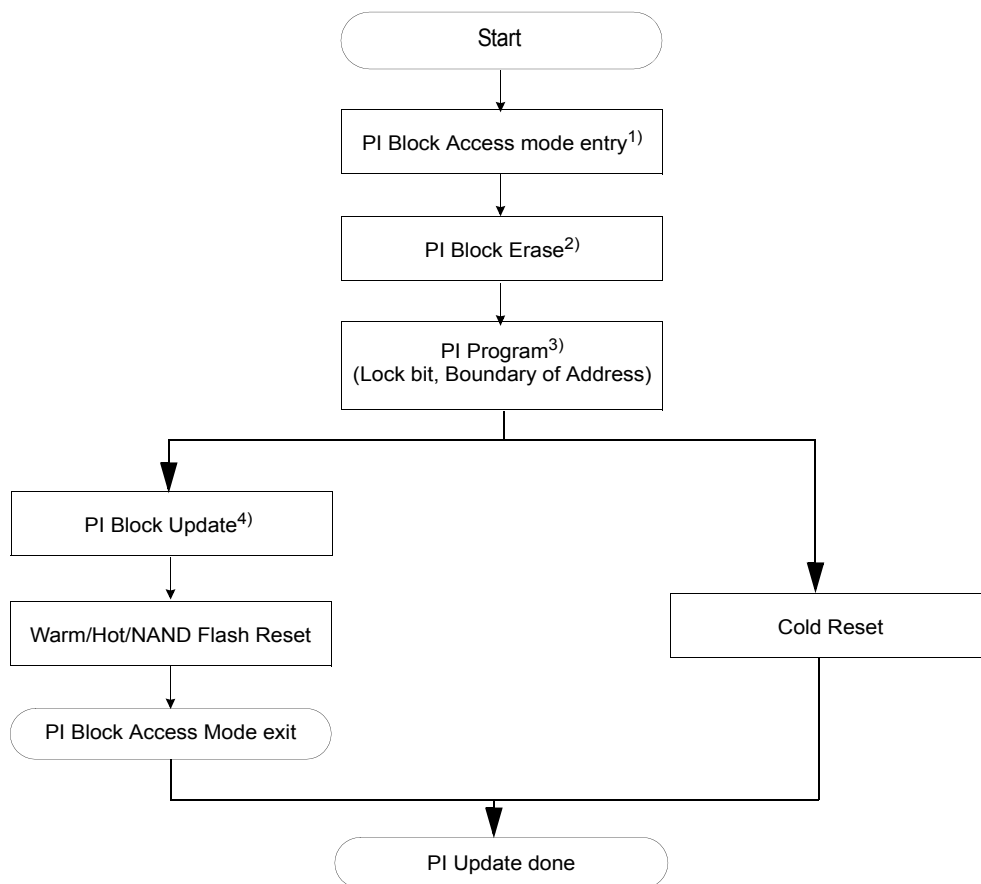

NOTE :

- 1) Refer to Chapter 3.12.1.1
- 2) Refer to Chapter 3.12.1.2
- 3) Refer to Chapter 3.12.1.3
- 4) Refer to Chapter 3.12.1.4

3.12.1.1 PI Block Access mode entry

The PI area is a separate part of the NAND Flash Array memory. It is accessed by issuing PI Access command(66h) instead of writing a Flash Block Address(FBA) in the StartAddress1 register.

After being accessed through the PI Access Command, the contents of PI memory area can be programmed, erased or loaded using the same operations as a normal program, erase or load operation to the NAND Flash Array memory.

PI Block Access mode entry Flow Chart

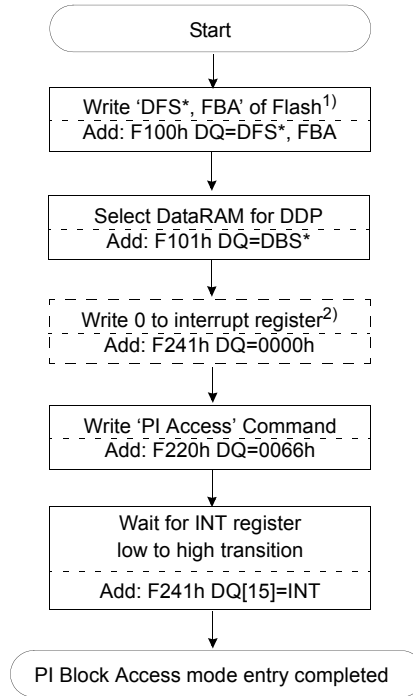

* DBS, DFS is for DDP

NOTE :

1) FBA(NAND Flash Block Address) could be omitted or any address.

2) 'Write 0 to interrupt register' step may be ignored when using INT auto mode. Refer to chapter 2.8.18.1

3.12.1.2 PI Block Erase

The PI Block Erase Operation erases the entire PI block including Partition Information. PI Block Access mode entry must be done before issuing Erase operation for PI Block.

Erasing the PI Area

- Issue the PI Access Command(Refer to Chapter 3.12.1.1).
- Issue an Erase command to erase the PI area.

PI Block Erase Operation Flow Chart (In PI Block Access Mode)

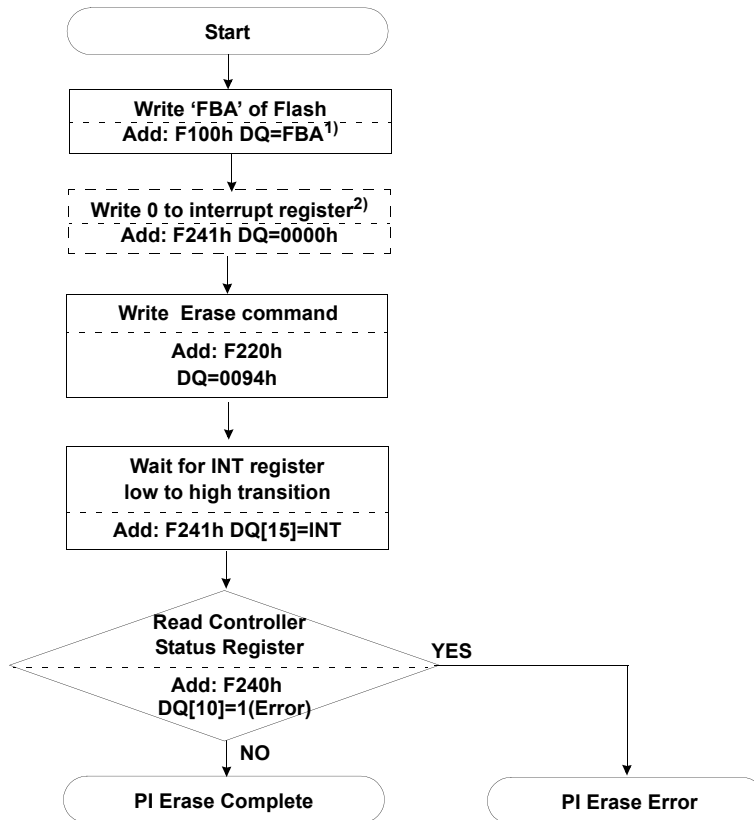

* DBS, DFS is for DDP

NOTE :

1) FBA(NAND Flash Block Address) must be 0000h.

2) 'Write 0 to interrupt register' step may be ignored when using INT auto mode. Refer to chapter 2.8.18.1

3.12.1.3 PI Block Program Operation

The PI Block Program Operation accesses the PI area and programs content from the DataRAM on-chip buffer to the designated page(s) of the PI.

A memory location in the PI area can be program.

The PI area is programmed using the same sequence as normal program operation after being accessed by the PI Block Access mode entry command (see section 3.8 for more information).

Programming the PI Area

- Issue the PI Access Command(Refer to Chapter 3.12.1.1).
- Write data into the DataRAM
 - In case of PI Lock(Add: 0200h, DQ=3XXXh, The lower 10 bits[9:0] are boundary address) .
 - In case of PI Unlock(Add: 0200h, DQ=FXXXh, The lower 10 bits[9:0] are boundary address).
- Write 0000h into Flash Block Address (FBA), that is address of NAND Flash Array address map.
- Issue a Program command to program the data from the DataRAM into the PI.

PI Block Program Operation Flow Chart (In PI Block Access Mode)

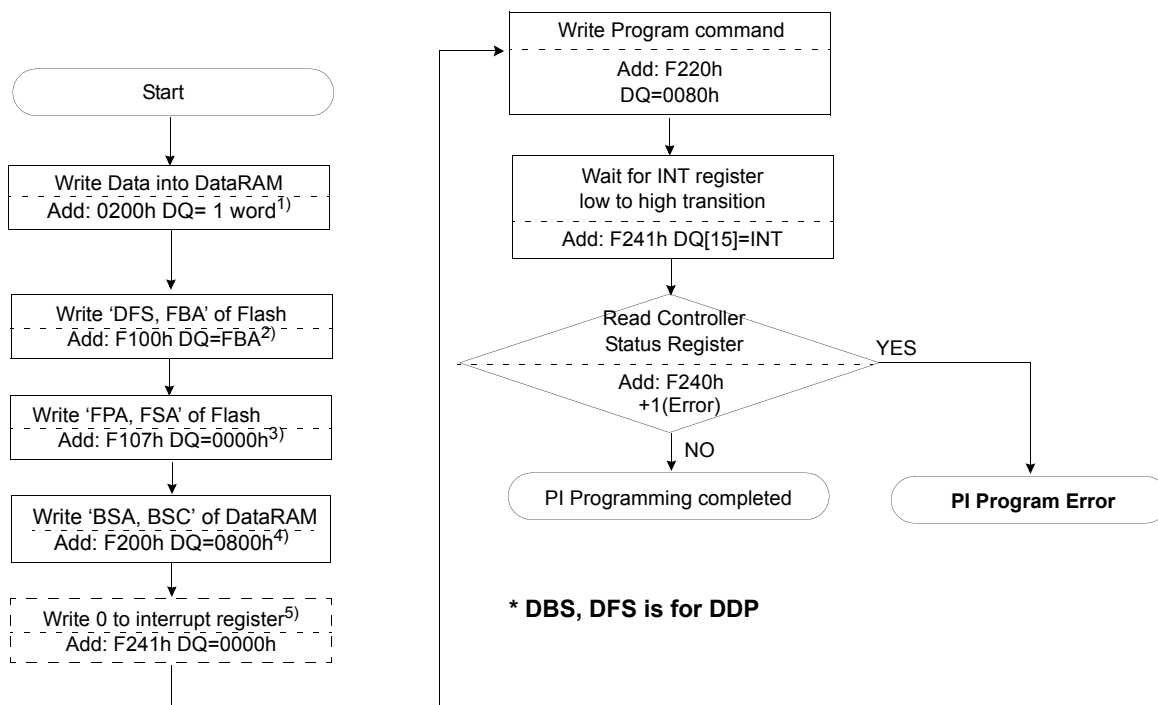

Locking the PI

Programming to PI block can be prevented by locking the PI area. Locking the PI area is accomplished by programming 3XXXh to 1st word of sector0 of main of the page0 memory area in the PI block(XXXh out of 3XXXh is a boundary block address that ends SLC area). Once Lock bits are programmed as lock status, PI block will be protected from program and erase. Boundary address is alterable before PI block is locked, but it is not recommended.

At device power-up and PI Update operation, this word is updated internally. If 3XXXh is found(i.e. the status of PI is locked), Program/Erase operations to PI block result in an error and the device updates the Error Bit of the Controller Status Register as "1"(fail).

NOTE :

- 1) Only the 1st word of 1st page of PI block (PI block Boundary Information) can be programmed in PI Block. The rest of the block cannot be programmed.
- 2) FBA(NAND Flash Block Address) must be 0000h.
- 3) FPA must be 00h and FSA must be 00.
- 4) BSA must be 1000 and BSC must be 000.
- 5) 'Write 0 to interrupt register' step may be ignored when using INT auto mode. Refer to chapter 2.8.18.1

3.12.1.4 PI Update

Once new partition information is programmed into the PI block, an internal register that is invisible to users must be updated for the changes in PI to be applied. This internal register which stores partition information(i.e. the last address of SLC area and lock bits) will be automatically updated through cold reset. However, the internal register can also be updated by issuing Partition Information Update command(05h) after PI Access mode entry.

Update the PI Area

- Issue the PI Access mode(Refer to Chapter 3.12.1.1).
- Issue the update PI command.

PI Block Update (In PI Block Access Mode)

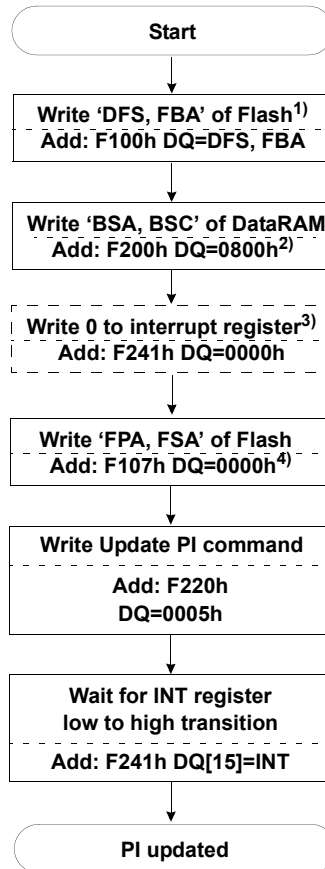

* DBS, DFS is for DDP

NOTE :

- 1) FBA(NAND Flash Block Address) must be 0000h.
- 2) BSA must be 1000 and BSC must be 000.
- 3) 'Write 0 to interrupt register' step may be ignored when using INT auto mode. Refer to chapter 2.8.18.1
- 4) FPA must be 00h and FSA must be 00.

3.12.2 PI Block Load Operation

A PI Block Load Operation accesses the PI area and transfers identified content from the PI to the DataRAM on-chip buffer, thus making the PI contents available to the Host.

The PI area is a separate part of the NAND Flash Array memory. It is accessed by issuing PI Access command(66h).

After being accessed with the PI Access Command, the contents of PI memory area are loaded using the same operations as a normal load operation to the NAND Flash Array memory (see section 3.6 for more information).

To exit the PI access mode after an PI Block Load Operation, a Cold-, Warm-, Hot-, or NAND Flash Core Reset operation is performed.

PI Block Read Operation Flow Chart (In PI Block Access Mode)

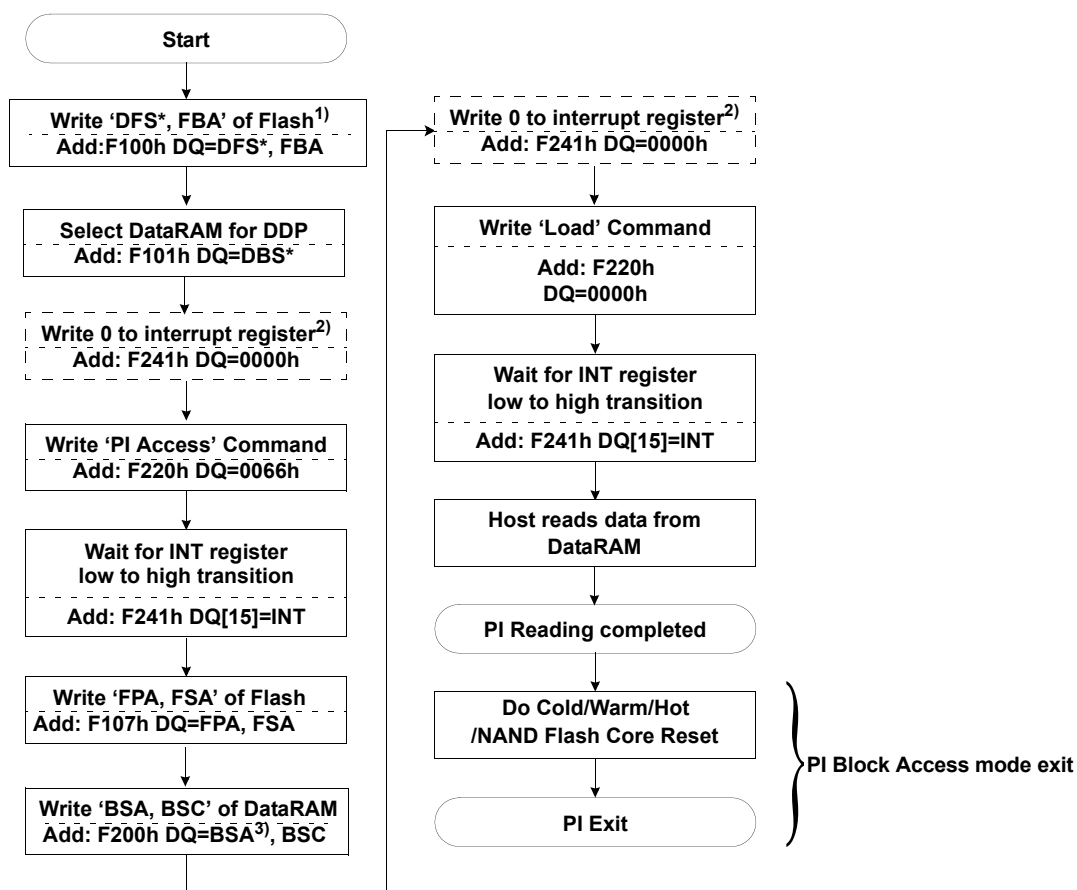

* DBS, DFS is for DDP

NOTE :

- 1) FBA(NAND Flash Block Address) could be omitted or any address.
- 2) 'Write 0 to interrupt register' step may be ignored when using INT auto mode. Refer to chapter 2.8.18.1
- 3) BSA must be 1000.

3.13 OTP Operation (SLC only)

One Block of the NAND Flash Array memory is reserved as a One-Time Programmable Block memory area. Also, 1st Block of NAND Flash Array can be used as OTP. OTP area and 1st block OTP area must be utilized as a SLC block.

The OTP block can be read, programmed and locked using the same operations as any other NAND Flash Array memory block. OTP block cannot be erased. Note that Cache program and Finish Cache program cannot be performed on OTP and 1st Block OTP area.

OTP block is fully-guaranteed to be a valid block by an internal ECC engine.

Entering the OTP Block

The OTP block is separately accessible from the rest of the NAND Flash Array by using the OTP Access command instead of the Flash Block Address (FBA).

Exiting the OTP Block

To exit the OTP Access Mode, a Cold-, Warm-, Hot-, or NAND Flash Core Reset operation is performed.

Exiting the OTP Block during an Erase Operation

If the Reset-triggered exit from the OTP Access Mode happens during an Erase Suspend Operation, the erase routine could fail. Therefore to exit from the OTP Access Mode without suspending the erase operation, a 'NAND Flash Core Reset' command should be issued.

The OTP Block Page Assignment

OTP area is one block size (128KB+4KB, 64 Pages) and is divided into two areas. The 50-page User Area is available as an OTP storage area. The 14-page Manufacturer Area is programmed by the manufacturer prior to shipping the device to the user.

OTP Block Page Allocation Information

Area	Page	Use
User	0 ~ 49 (50 pages)	Designated as user area
Manufacturer	50 ~ 63 (14 pages)	Used by the device manufacturer

Three Possible OTP Lock Sequence (Refer to Chapter 3.13.3~3.13.5 for more information)

Since OTP Block and 1st Block OTP can be locked only by programming into 1st word of sector4, page49 of the main memory area of OTP, OTP Block and 1st Block OTP lock sequence is restricted into three following cases.

Note that user should be careful, because locking OTP Block before locking 1st Block OTP will disable locking 1st Block OTP.

1. OTP Block Lock Only :
Once the OTP Block is locked, 1st Block OTP Lock is impossible.
2. 1st Block OTP Lock Only:
Locking 1st Block OTP does not lock the OTP block, but the OTP Block Lock cannot be performed thereafter.
3. OTP Block Lock and 1st Block OTP Lock simultaneously:
This simultaneous operation can be done by programming into 1st word of sector4, page49 of the main memory area of OTP.

OTP Block Area Structure

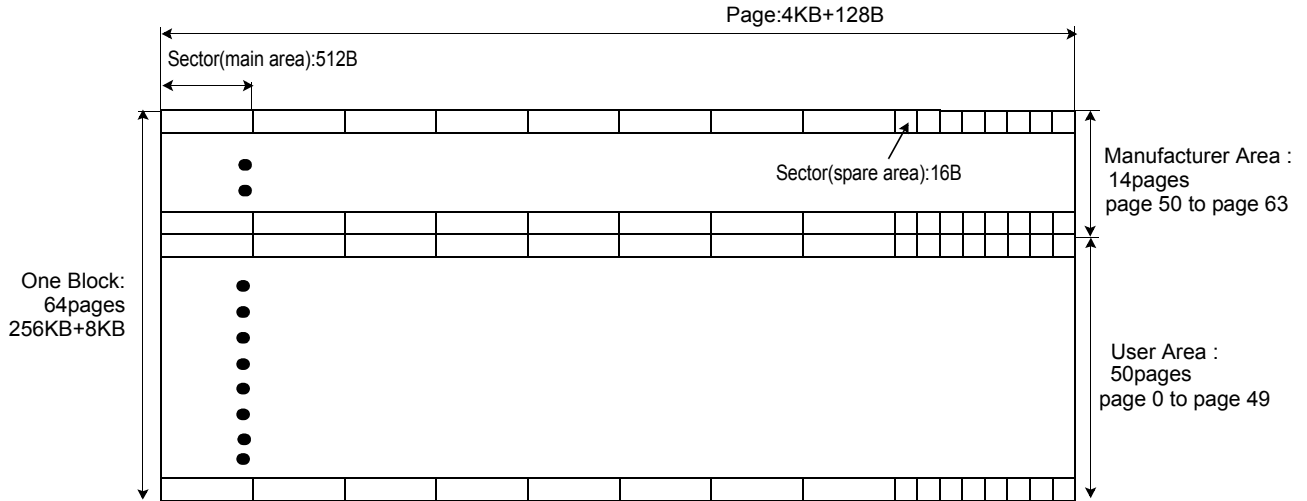

1st Block OTP Area Structure

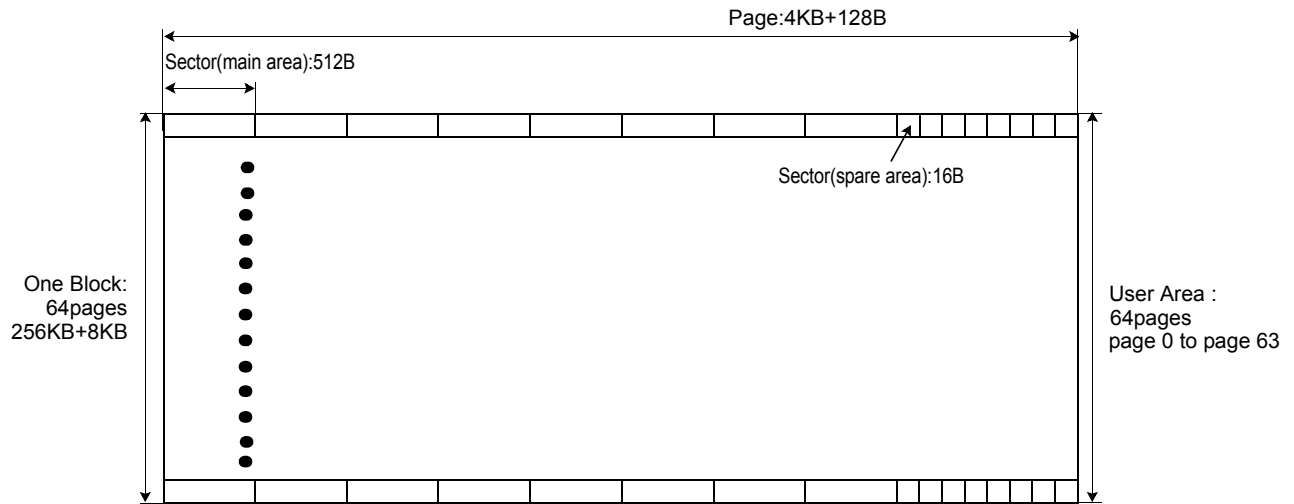

3.13.1 OTP Block Load Operation

An OTP Block Load Operation accesses the OTP area and transfers identified content from the OTP to the DataRAM on-chip buffer, thus making the OTP contents available to the Host.

The OTP area is a separate part of the NAND Flash Array memory. It is accessed by issuing OTP Access command(65h) instead of a Flash Block Address (FBA) value in Start Address1 Register.

After being accessed with the OTP Access Command, the contents of OTP memory area are loaded using the same operations as a normal load operation to the NAND Flash Array memory (see section 3.6 for more information).

To exit the OTP access mode after an OTP Block Load Operation, a Cold-, Warm-, Hot-, or NAND Flash Core Reset operation is performed.

OTP Block Read Operation Flow Chart

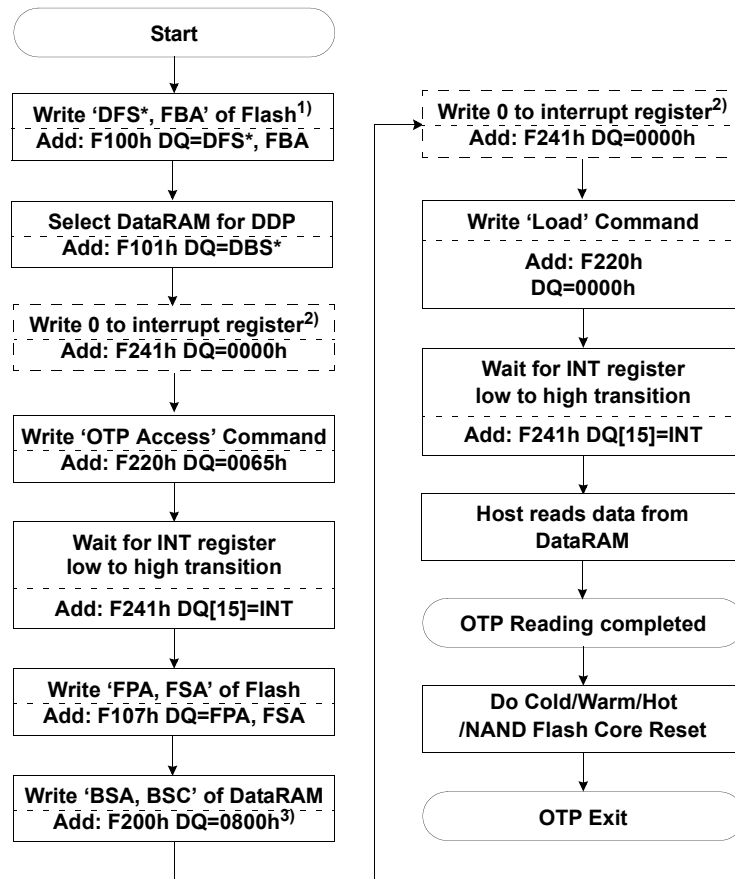

* DBS, DFS is for DDP

NOTE :

1) FBA(NAND Flash Block Address) could be omitted or any address

2) 'Write 0 to interrupt register' step may be ignored when using INT auto mode. Refer to chapter 2.8.18.1

3) BSA must be 1000 and BSC must be 000.

3.13.2 OTP Block Program Operation

An OTP Block Program Operation accesses the OTP area and programs content from the DataRAM on-chip buffer to the designated page(s) of the OTP.

A memory location in the OTP area can be programmed only one time (no erase operation permitted).

The OTP area is programmed using the same sequence as normal program operation after being accessed by the command (see section 3.9 for more information).

Programming the OTP Area

- Issue the OTP Access Command
- Write data into the DataRAM (data can be input at anytime between the "Start" and "Write Program commands").
- Issue a Flash Block Address (FBA) which is 0000h of NAND Flash Array address map.
- Issue a Program command to program the data from the DataRAM into the OTP
- When the OTP Block programming is complete,
do a Cold-, Warm-, Hot-, NAND Flash Core Reset to exit the OTP Access mode.

OTP Block Program Operation Flow Chart

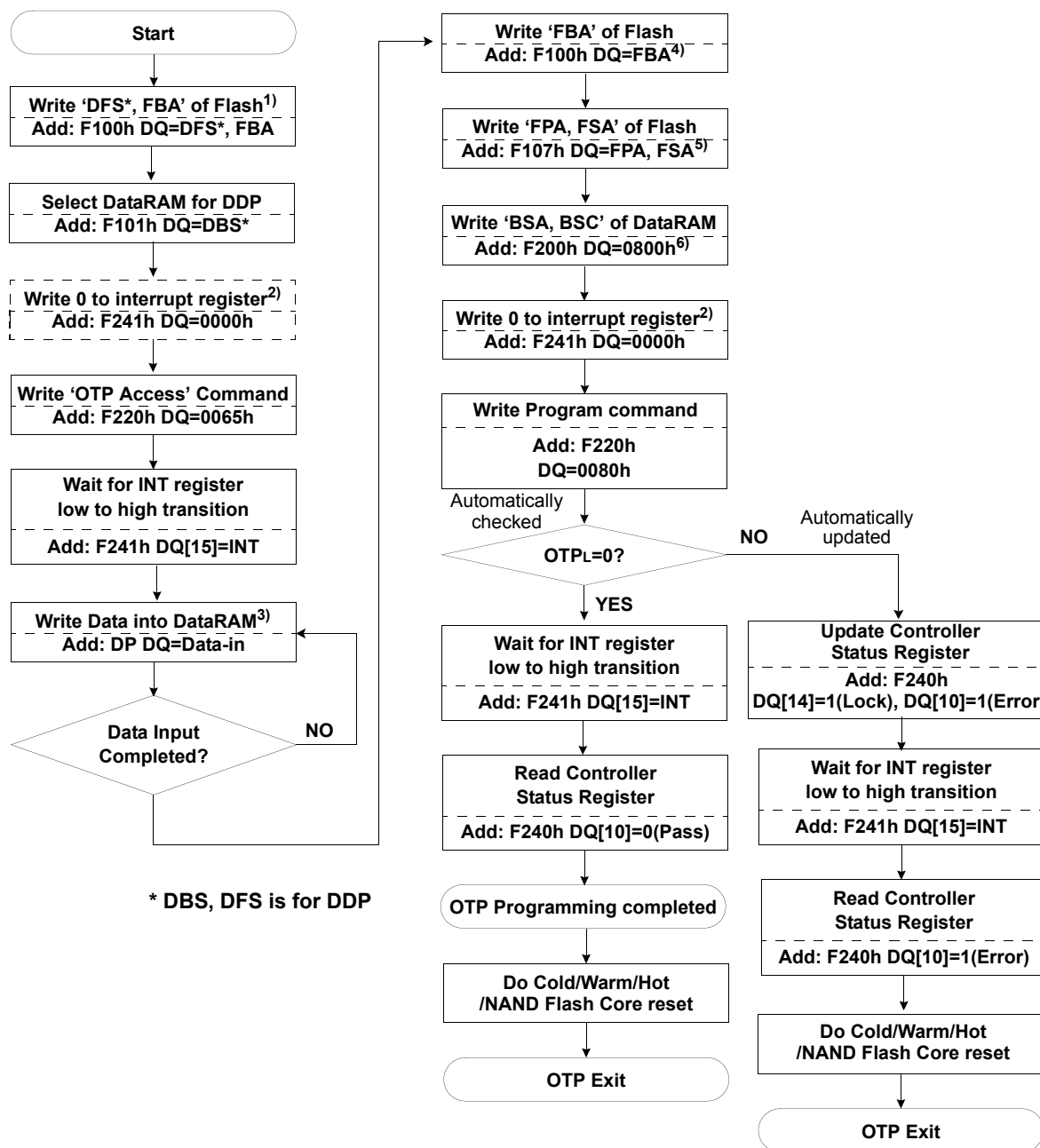

* DBS, DFS is for DDP

NOTE :

- 1) FBA(NAND Flash Block Address) could be omitted or any address.
- 2) 'Write 0 to interrupt register' step may be ignored when using INT auto mode. Refer to chapter 2.8.18.1
- 3) Data input could be done anywhere between "Start" and "Write Program Command".
- 4) FBA must be 0000.
- 5) FSA must be 00 within program operation.
- 6) BSA must be 1000 and BSC must be 000.

3.13.3 OTP Block Lock Operation

Even though the OTP area can only be programmed once without erase capability, it can be locked when the device starts up to prevent any changes from being made.

Unlike the main area of the NAND Flash Array memory, **once the OTP block is locked, it cannot be unlocked, for locking bit for both blocks lies in the same word of OTP area.**

Therefore, if OTP Block is locked prior to 1st Block OTP lock, 1st Block OTP cannot be locked.

Locking the OTP

Programming to the OTP area can be prevented by locking the OTP area. Locking the OTP area is accomplished by programming **XXFCh** to the 1st word of sector4 of main of the page49 memory area in the OTP block.

At device power-up, this word location is checked and if **XXFCh** is found, the OTP_L bit of the Controller Status Register is set to "1", indicating the OTP is locked. When the Program Operation finds that the status of the OTP is locked, the device updates the Error Bit of the Controller Status Register as "1" (fail).

OTP Lock Operation Steps

- Issue the OTP Access Command
- Fill data to be programmed into DataRAM (data can be input at anytime between the "Start" and "Write Program" commands)
- Write '**XXFCh**' data into the 1st word of sector4 of main of the page49 memory area of the DataRAM.
- Issue a Flash Block Address (FBA) which is 0000h of NAND Flash Array address map.
- Issue a Program command to program the data from the DataRAM into the OTP
- When the OTP lock is complete, do a Cold Reset to exit the OTP Access mode and update OTP lock bit[6].
- OTP lock bit[6] of the Controller Status Register will be set to "1" and the OTP will be locked.

OTP Block Lock Operation Flow Chart

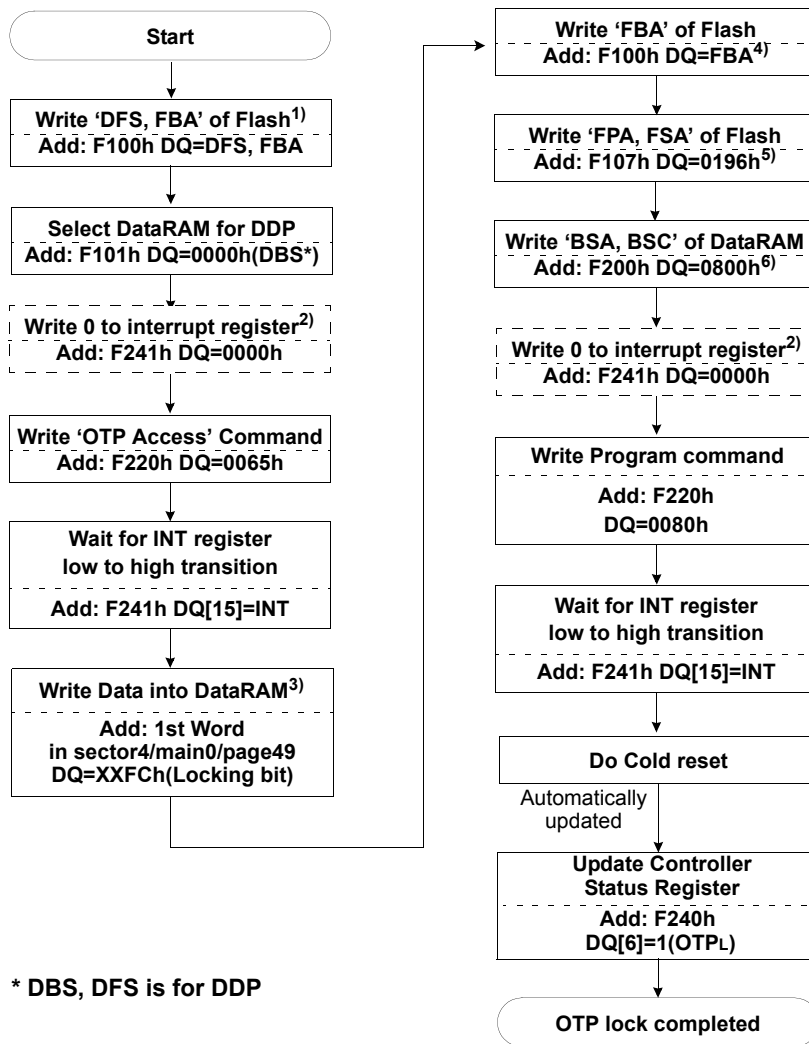

NOTE :

- 1) FBA(NAND Flash Block Address) could be omitted or any address.
- 2) 'Write 0 to interrupt register' step may be ignored when using INT auto mode. Refer to chapter 2.8.18.1
- 3) Data input could be done anywhere between "Start" and "Write Program Command".
- 4) FBA must be 0000.
- 5) FSA must be 00 within program operation. The 0196h is the page49 of NAND Flash Array address map.
- 6) BSA must be 1000 and BSC must be 000.

3.13.4 1st Block OTP Lock Operation

1st Block can be used as OTP, for secured booting operation.

1st Block OTP can be accessed just as any other NAND Flash Array Blocks before it is locked, however, once 1st Block is locked to be OTP, 1st Block OTP cannot be erased or programmed.

Note that once OTP Block is locked, 1st Block OTP lock is impossible also OTP Block cannot be locked freely after locking 1st Block OTP. OTP Block and 1st Block OTP should be locked at the same time.

Locking the 1st Block OTP

Programming to the 1st Block OTP area can be prevented by locking the OTP area. Locking the OTP area is accomplished by programming **XXF3h** to the 1st word of sector4 of main of the page49 memory area in the OTP block.

At device power-up, this word location is checked and if **XXF3h** is found, the OTP_{BL} bit of the Controller Status Register is set to "1", indicating the 1st Block is locked. When the Program Operation finds that the status of the 1st Block is locked, the device updates the Error Bit of the Controller Status Register as "1" (fail).

1st Block OTP Lock Operation Steps

- Issue the OTP Access Command
- Fill data to be programmed into DataRAM (data can be input at anytime between the "Start" and "Write Program" commands)
- Write '**XXF3h**' data into the 1st word of sector4 of main of the page49 memory area of the DataRAM.
- Issue a Flash Block Address (FBA) which is 0000h of NAND Flash Array address map.
- Issue a Program command to program the data from the DataRAM into the OTP
- When the 1st Block OTP lock is complete, do a Cold Reset to exit the OTP Access mode and update 1st Block OTP lock bit[5].
- 1st Block OTP lock bit[5] of the Controller Status Register will be set to "1" and the 1st Block will be locked.

Even though the OTP area can only be programmed once without erase capability, it can be locked when the device starts up to prevent any changes from being made.

Unlike other remaining main area of the NAND Flash Array memory, **once the 1st block OTP is locked, it cannot be unlocked.**

Once 1st block is set as OTP, NAND Flash Write Protection status register(F24Eh) indicates only 'Lock' state although 'Lock tight' or 'Unlock' command is issued.

1st Block OTP Lock Operation Flow Chart

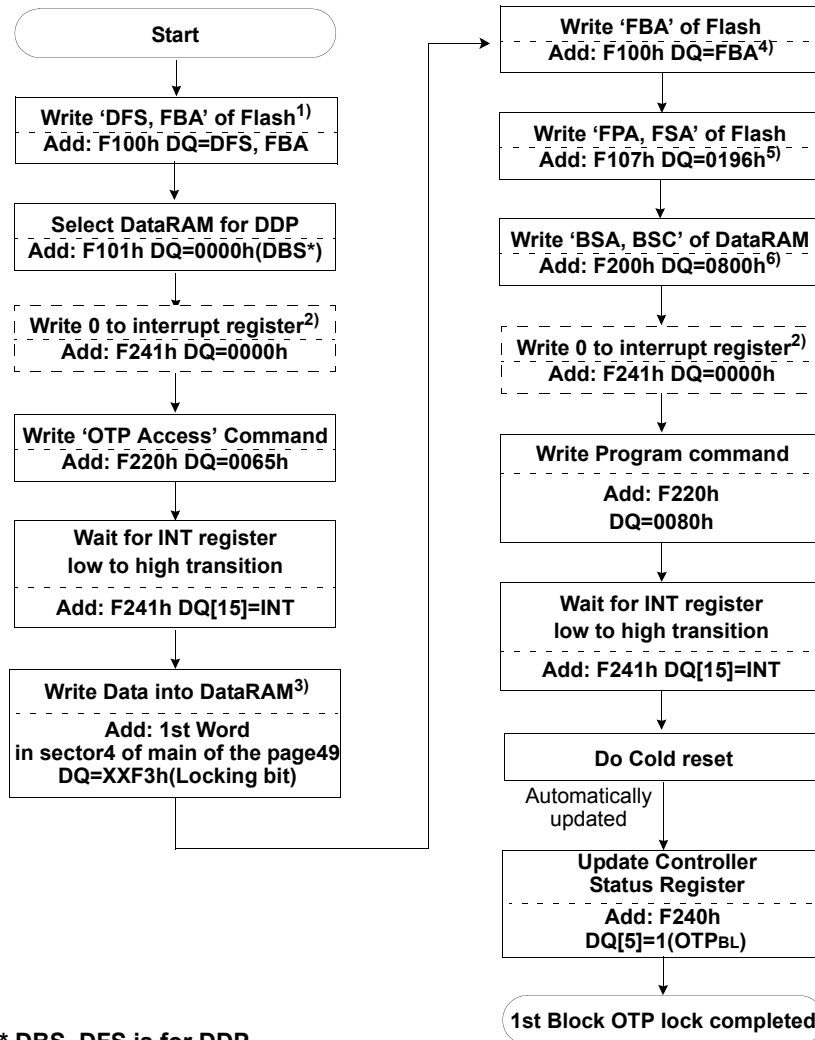

* DBS, DFS is for DDP

NOTE :

- 1) FBA(NAND Flash Block Address) could be omitted or any address.
- 2) 'Write 0 to interrupt register' step may be ignored when using INT auto mode. Refer to chapter 2.8.18.1
- 3) Data input could be done anywhere between "Start" and "Write Program Command".
- 4) FBA must be 0000.
- 5) FSA must be 00 within program operation. The 0196h is the page49 of NAND Flash Array address map.
- 6) BSA must be 1000 and BSC must be 000.

3.13.5 OTP and 1st Block OTP Lock Operation

OTP and 1st Block can be locked simultaneously, for locking bit lies in the same word of OTP area.

1st Block OTP can be accessed just as any other NAND Flash Array Blocks before it is locked, however, once 1st Block is locked to be OTP, 1st Block OTP cannot be erased or programmed. Also, OTP area can only be programmed once without erase capability, it can be locked when the device starts up to prevent any changes from being made.

Locking the OTP and 1st Block OTP

Programming to the OTP area and 1st Block OTP area can be prevented by locking the OTP area. Locking the OTP area is accomplished by programming **XXF0h** to the 1st word of sector4 of main of the page49 memory area in the OTP block.

At device power-up, this word location is checked and if **XXF0h** is found, the OTP_L and OTP_{BL} bit of the Controller Status Register is set to "1", indicating the OTP and 1st Block is locked. When the Program Operation finds that the status of the OTP and 1st Block is locked, the device updates the Error Bit of the Controller Status Register as "1" (fail).

OTP and 1st Block OTP simultaneous Lock Operation Steps

- Issue the OTP Access Command
- Fill data to be programmed into DataRAM (data can be input at anytime between the "Start" and "Write Program" commands)
- Write '**XXF0h**' data into the 1st word of sector4 of main of the page49 memory area of the DataRAM.
- Issue a Flash Block Address (FBA) which is 0000h of NAND Flash Array address map.
- Issue a Program command to program the data from the DataRAM into the OTP
- When the 1st Block OTP lock is complete, do a Cold Reset to exit the OTP Access mode and update 1st Block OTP lock bit[5] and OTP lock bit[6].
- 1st Block OTP lock bit[5] and OTP lock bit[6] of the Controller Status Register will be set to "1" and the OTP and 1st Block will be locked.

Unlike other remaining main area of the NAND Flash Array memory, **once the OTP block and the 1st block OTP are locked, it cannot be unlocked.**

OTP and 1st Block OTP Lock Operation Flow Chart

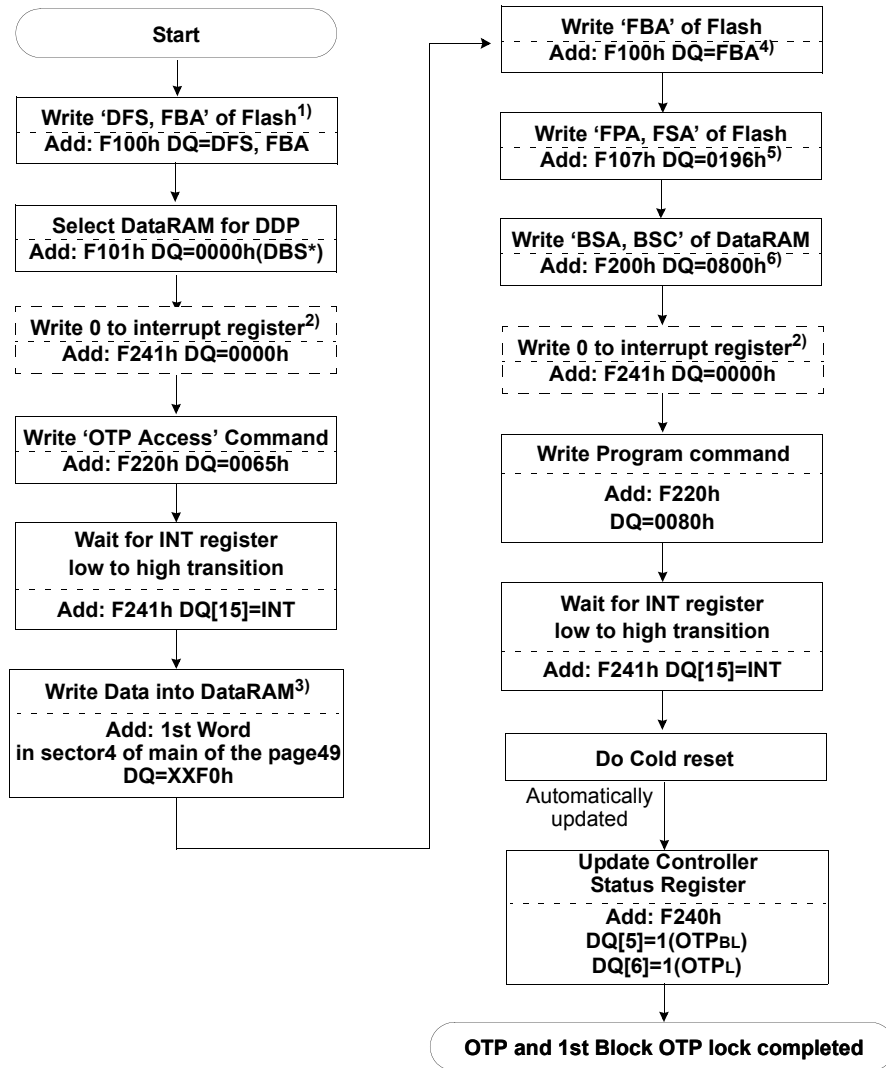

* DBS, DFS is for DDP

NOTE :

- 1) FBA(NAND Flash Block Address) could be omitted or any address.
- 2) 'Write 0 to interrupt register' step may be ignored when using INT auto mode. Refer to chapter 2.8.18.1
- 3) Data input could be done anywhere between "Start" and "Write Program Command".
- 4) FBA must be 0000.
- 5) FSA msut be 00 within program operation. The 0196h is the page49 of NAND Flash Array address map.
- 6) BSA msut be 1000 and BSC must be 000.

3.14 ECC Operation

The Flex-OneNAND device has on-chip ECC with the capability of correcting up to 4-bit errors in the NAND Flash Array memory main and spare areas (512+16)B.

As the device transfers data from a BufferRAM to the NAND Flash Array memory Page Buffer for Program Operation, the device initiates a background operation which generates an Error Correction Code (ECC).

During a Load operation from the NAND Flash Array memory Page, the on-chip ECC engine generates a new ECC. The 'Load ECC result' is compared to the originally programmed ECC' thus detecting the number of errors. Up to 4-bit errors are corrected.

ECC is updated by the device automatically. After a Load Operation, the Host can determine whether there was error by reading the 'ECC Status Register' (Refer to section 2.8.26~2.8.29).

Error types are divided into 'no error', 'correctable error(1bit~4bit)', and 'uncorrectable error(more than 4bit)'.

When the device reads the NAND Flash Array memory main and spare area data with an ECC operation, the device doesn't place the newly generated ECC for main and spare area into the buffer. Instead it places the ECC which was generated and written during the program operation into the buffer.

An ECC operation is also done during the Boot Loading operation.

3.14.1 ECC Bypass Operation

In an ECC bypass operation, the device does not generate ECC as a background operation.

In a Program Operation the ECC code to NAND Flash Array memory spare area is not updated. During a Load operation, the on-chip ECC engine does not generate a new ECC internally. Also the ECC Status Registers are invalid. The error is not corrected and detected by itself, so that ECC bypass operation is not recommended for host.

ECC bypass operation is set by the 9bit of System Configuration 1 Register (see section 2.8.19)

ECC Code and ECC Result by ECC Operation

Operation	Program operation	Load operation		
	ECC Code Update to NAND Flash Array Spare Area	ECC Code at BufferRAM Spare Area	ECC Status & Result Update to Registers	1bit~4bit Error
ECC operation	Update	Pre-written ECC code ¹⁾ loaded	Update	Correct
ECC bypass	Not update	Pre-written code ¹⁾ loaded	Invalid	Not correct

NOTE :

1) Pre-written ECC code : ECC code which is previously written to NAND Flash Spare Area in program operation.

3.15 Invalid Block Operation

Invalid blocks are defined as blocks in the device's NAND Flash Array memory that contain five or more invalid bits which cause status failure during Program and Erase operation.

The information regarding the invalid block(s) is called the Invalid Block Information. Devices with invalid block(s) have the same quality level as devices with all valid blocks and have the same AC and DC characteristics.

An invalid block(s) does not affect the performance of valid block(s) because it is isolated from the bit line and the common source line by a select transistor.

The system that adopts Flash memory must be able to mask out the invalid block(s) by software. The 1st block is always fully guaranteed to be a valid block by an internal ECC engine.

Due to invalid marking, during load operation for indentifying invalid block, a load error may occur.

3.15.1 Invalid Block Identification Table Operation

A system must be able to recognize invalid block(s) based on the original invalid block information and create an invalid block table.

Invalid blocks are identified by erasing all address locations in the NAND Flash Array memory except locations where the invalid block(s) information is written prior to shipping.

An invalid block(s) status is defined by the 1st word in the spare area. Samsung makes sure that the first page in the block either SLC partition or MLC partition of every invalid block has non-FFFFh data at the 1st word of sector0 of pages 0 or 1 in the spare area.

Since the invalid block information is also erasable in most cases, it is impossible to recover the information once it has been erased. Any intentional erase of the original invalid block information is prohibited.

The following suggested flow chart can be used to create an Invalid Block Table.

Invalid Block Table Creation Flow Chart

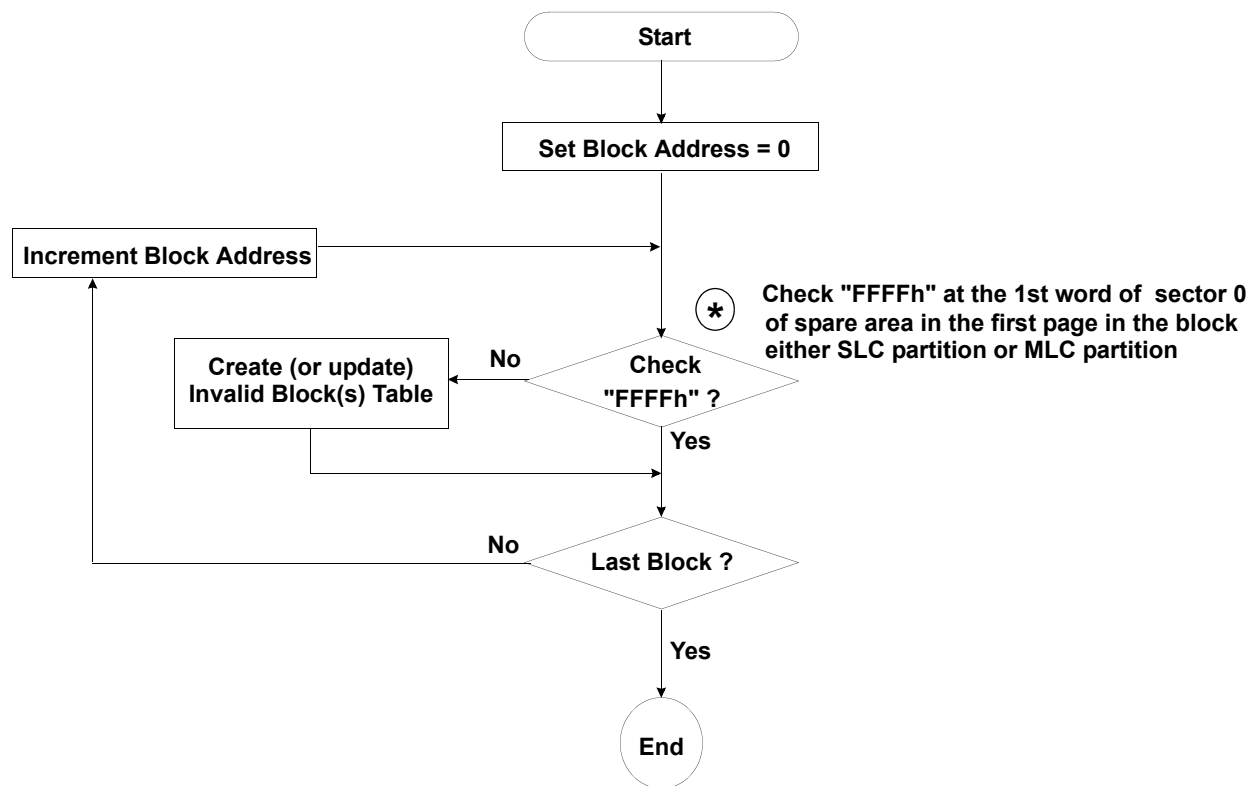

3.15.2 Invalid Block Replacement Operation

Within its life time, additional invalid blocks may develop with NAND Flash Array memory. Refer to the device's qualification report for the actual data.

The following possible failure modes should be considered to implement a highly reliable system.

In the case of a status read failure after erase or program, a block replacement should be done. Program status failure during a page program does not affect the data of the other pages in the same block within a SLC partition, while Program status failure could contaminate the data of the paired page within a MLC partition. So, users must make sure how software handle the program failure occurs.

Block Failure Modes and Countermeasures

Failure Mode	Detection and Countermeasure sequence
Erase Failure	Status Read after Erase --> Block Replacement
Program Failure	Status Read after Program --> Block Replacement
Four Bit Failure in Load Operation	Error Correction by ECC mode of the device

Referring to the diagram for further illustration, when an error happens in the nth page of block 'A' during program operation, copy the data in the 1st ~ (n-1)th page to the same location of block 'B' via DataRAM. Then re-program the nth page to the nth page of block 'B' or any free block. Do not further erase or program block 'A' but instead complete the operation by creating an 'Invalid Block Table' or other appropriate scheme.

Block Replacement Operation Sequence

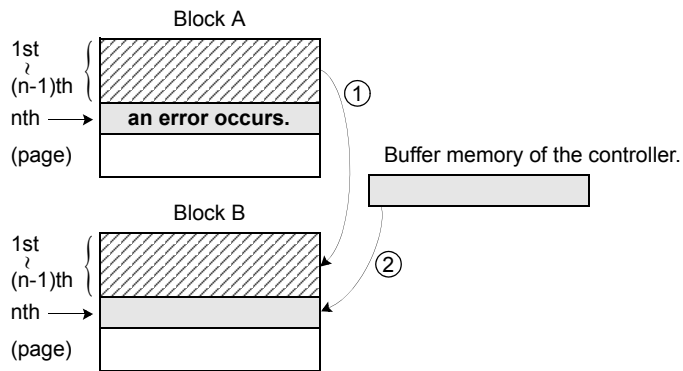

4.0 DC CHARACTERISTICS

4.1 Absolute Maximum Ratings

Parameter	Symbol	Rating	Unit
Voltage on any pin relative to Vss	Vcc	-0.5 to +2.45	V
	All Pins	V _{IN}	
Temperature Under Bias	T _{bias}	-30 to +125	°C
		Industrial	
Storage Temperature	T _{stg}	-65 to +150	°C
Short Circuit Output Current	I _{os}	5	mA
Recommended Operating Temperature	T _A (Extended Temp.)	-30 to +85	°C
	T _A (Industrial Temp.)	-40 to +85	

NOTE :

- 1) Minimum DC voltage is -0.5V on Input/ Output pins. During transitions, this level should not fall to POR level(typ.1.5V@1.8V, typ.1.8V@3.3V device). Maximum DC voltage may overshoot to Vcc+2.0V for periods <20ns.
- 2) Permanent device damage may occur if ABSOLUTE MAXIMUM RATINGS are exceeded. Functional operation should be restricted to the conditions detailed in the operational sections of this data sheet. Exposure to absolute maximum rating conditions for extended periods may affect reliability.

4.2 Operating Conditions

Voltage reference to GND

Parameter	Symbol	KFG4GH6Q4M			KFG4GH6U4M			Unit
		Min	Typ.	Max	Min	Typ.	Max	
Supply Voltage	Vcc-core / Vcc	1.7	1.8	1.95	2.6	3.3	3.6	V
	Vcc-IO / Vccq							
	Vss	0	0	0	0	0	0	

NOTE :

- 1) Vcc-Core (or Vcc) should reach the operating voltage level prior to or at the same time as Vcc-IO (or Vccq).

4.3 DC Characteristics

Parameter	Symbol	Test Conditions	RMS Value						Unit	
			1.8V device			3.3V device				
			Min	Typ	Max	Min	Typ	Max		
Input Leakage Current	I _{LI}	V _{IN} =V _{SS} to V _{CC} , V _{CC} =V _{CCmax}	Single	- 1.0	-	+ 1.0	- 1.0	-	+ 1.0	μA
			DDP	- 2.0	-	+ 2.0	- 2.0	-	+ 2.0	
Output Leakage Current	I _{LO}	V _{OUT} =V _{SS} to V _{CC} , V _{CC} =V _{CCmax} , \overline{CE} or \overline{OE} =V _{IH} (Note 1)	Single	- 1.0	-	+ 1.0	- 1.0	-	+ 1.0	μA
			DDP	- 2.0		+ 2.0	- 2.0		+ 2.0	
Active Asynchronous Read Current (Note 2)	I _{CC1}	\overline{CE} =V _{IL} , \overline{OE} =V _{IH}		-	8	15	-	20	25	mA
Active Burst Read Current (Note 2)	I _{CC2R}	\overline{CE} =V _{IL} , \overline{OE} =V _{IH} , \overline{WE} =V _{IH}	66MHz	-	20	30	-	30	40	mA
			83MHz	-	25	35	-	-	-	mA
			1MHz	-	3	4	-	3	6	mA
			66MHz (DDP)	-	22	35	-	35	50	mA
			83MHz (DDP)	-	26	40	-	-	-	mA
			1MHz (DDP)	-	3	4	-	7	9	mA
Active Burst Write Current (Note 2)	I _{CC2W}	\overline{CE} =V _{IL} , \overline{OE} =V _{IH} , \overline{WE} =V _{IL}	66MHz	-	20	30	-	-	-	mA
			83MHz	-	25	35	-	-	-	mA
			1MHz	-	3	4	-	-	-	mA
			66MHz (DDP)	-	22	35	-	-	-	mA
			83MHz (DDP)	-	26	40	-	-	-	mA
			1MHz (DDP)	-	3	4	-	-	-	mA
Active Asynchronous Write Current (Note 2)	I _{CC3}	\overline{CE} =V _{IL} , \overline{OE} =V _{IH}	Single	-	8	15	-	15	25	mA
			DDP	-	17	25	-	30	40	mA
Active Load Current (Note 3)	I _{CC4}	\overline{CE} =V _{IL} , \overline{OE} =V _{IH} , \overline{WE} =V _{IH}		-	50	65	-	55	75	mA
Active Program Current (Note 3)	I _{CC5}	\overline{CE} =V _{IL} , \overline{OE} =V _{IH} , \overline{WE} =V _{IH}		-	35	45	-	40	55	mA
Active Erase Current (Note 3)	I _{CC6}	\overline{CE} =V _{IL} , \overline{OE} =V _{IH} , \overline{WE} =V _{IH}		-	40	50	-	40	55	mA
Standby Current	I _{SB}	\overline{CE} = \overline{RP} =V _{CC} ± 0.2V	Single	-	10	50	-	35	80	μA
			DDP	-	20	100	-	70	160	
Input Low Voltage	V _{IL}	-		-0.5	-	0.4	0	-	0.8	V
Input High Voltage (Note 4)	V _{IH}	-		V _{CCq} -0.4	-	V _{CCq} +0.4	0.7* V _{CCq}	-	V _{CCq}	V
Output Low Voltage	V _{OL}	I _{OL} = 100 μA , V _{CC} =V _{CCmin} , V _{CCq} =V _{CCqmin}		-	-	0.2	-	-	0.2* V _{CCq}	V
Output High Voltage	V _{OH}	I _{OH} = -100 μA , V _{CC} =V _{CCmin} , V _{CCq} =V _{CCqmin}		V _{CCq} -0.1	-	-	0.8* V _{CCq}	-	-	V

NOTE :

- 1) \overline{CE} should be V_{IH} for RDY. IOBE should be '0' for INT.
- 2) I_{CC} active for Host access g3) I_{CC} active for Internal operation. (without host access)
- 4) V_{CCq} is equivalent to V_{CC}-IO

5.0 AC CHARACTERISTICS

5.1 AC Test Conditions

Parameter		Value (66MHz)	Value (83MHz)
Input Pulse Levels		0V to V _{CC}	0V to V _{CC}
Input Rise and Fall Times	CLK	3ns	2ns
	other inputs	5ns	2ns
Input and Output Timing Levels		V _{CC} /2	V _{CC} /2
Output Load		C _L = 30pF	C _L = 30pF

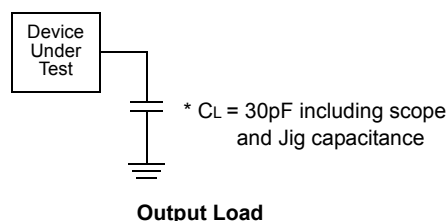
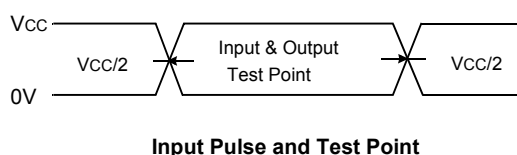

5.2 Device Capacitance

CAPACITANCE (T_A = 25 °C, V_{CC} = 1.8V, f = 1.0MHz)

Item	Symbol	Test Condition	Single		DDP		QDP		Unit
			Min	Max	Min	Max	Min	Max	
Input Capacitance	C _{IN1}	V _{IN} =0V	-	10	-	20	-	40	pF
Control Pin Capacitance	C _{IN2}	V _{IN} =0V	-	10	-	20	-	40	
Output Capacitance	C _{OUT}	V _{OUT} =0V	-	10	-	20	-	40	
INT Capacitance	C _{INT}	V _{OUT} =0V	-	10	-	20	-	40	

NOTE :

1) Capacitance is periodically sampled and not 100% tested.

5.3 Valid Block Characteristics

Parameter	Symbol	Min	Typ.	Max	Unit
Valid Block Number	Single	998	-	1024	Blocks
	DDP	1996	-	2048	
	QDP	3993	-	4096	

NOTE :

- The device may include invalid blocks when first shipped. Additional invalid blocks may develop while being used. The number of valid blocks is presented with both cases of invalid blocks considered. Invalid blocks are defined as blocks that contain five or more bad bits which cause status failure during Program and Erase operation. Do not erase or program factory-marked bad blocks.
- The 1st block, which is placed on 00h block address, is guaranteed to be a valid block up to 1K program/erase cycles with 4bit/528Byte ECC.

5.4 AC Characteristics for Synchronous Burst Read

See Timing Diagrams 6.1 and 6.2

Parameter	Symbol	66MHz		83MHz(1.8V only)		Unit
		Min	Max	Min	Max	
Clock	CLK	1	66	1	83	MHz
Clock Cycle	tCLK	15	-	12	-	ns
Initial Access Time	tIAA	-	70	-	70	ns
Burst Access Time Valid Clock to Output Delay	tBA	-	11	-	9	ns
$\overline{\text{AVD}}$ Setup Time to CLK	tAVDS	5	-	4	-	ns
$\overline{\text{AVD}}$ Hold Time from CLK	tAVDH	2	-	2	-	ns
Address Setup Time to CLK	tACS	5	-	4	-	ns
Address Hold Time from CLK	tACH	6	-	6	-	ns
Data Hold Time from Next Clock Cycle	tBDH	3	-	2	-	ns
Output Enable to Data	tOE	-	20	-	20	ns
$\overline{\text{CE}}$ Disable to Output & RDY High Z	tCEZ ¹⁾	-	20	-	20	ns
$\overline{\text{OE}}$ Disable to Output High Z	tOEZ ¹⁾	-	15	-	15	ns
$\overline{\text{CE}}$ Setup Time to CLK	tCES	6	-	4.5	-	ns
CLK High or Low Time	tCLKH/L	tCLK/3	-	5	-	ns
CLK ²⁾ to RDY valid	tRDYO	-	11	-	9	ns
CLK to RDY Setup Time	tRDYA	-	11	-	9	ns
RDY Setup Time to CLK	tRDYS	4	-	3	-	ns
$\overline{\text{CE}}$ low to RDY valid	tCER	-	15	-	15	ns

NOTE :

- 1) If $\overline{\text{OE}}$ is disabled at the same time or before $\overline{\text{CE}}$ is disabled, the output will go to high-z by tOEZ.
 If $\overline{\text{CE}}$ is disabled at the same time or before $\overline{\text{OE}}$ is disabled, the output will go to high-z by tCEZ.
 If $\overline{\text{CE}}$ and $\overline{\text{OE}}$ are disabled at the same time, the output will go to high-z by tOEZ.
- 2) It is the following clock of address fetch clock.

5.5 AC Characteristics for Asynchronous Read

See Timing Diagrams 6.3, 6.4, 6.5 and 6.6.

Parameter	Symbol	KFG4GH6x4M/ KFH8GH6x4M/ KFWAGH6x4M(TBD)		Unit
		Min	Max	
Access Time from \overline{CE} Low	tCE	-	76	ns
Asynchronous Access Time from \overline{AVD} Low	tAA	-	76	ns
Asynchronous Access Time from address valid	tACC	-	76	ns
Read Cycle Time	tRC	76	-	ns
\overline{AVD} Low Time	tAVDP	12	-	ns
Address Setup to rising edge of \overline{AVD}	tAAVDS	5	-	ns
Address Hold from rising edge of \overline{AVD}	tAAVDH	6	-	ns
Output Enable to Output Valid	tOE	-	20	ns
\overline{CE} Disable to Output & RDY High Z ¹⁾	tCEZ	-	20	ns
\overline{OE} Disable to Output High Z ¹⁾	tOEZ	-	15	ns
\overline{CE} Low to RDY Valid	tCER	-	15	ns
\overline{WE} Disable to \overline{AVD} Enable	tWEA	15	-	ns

NOTE :

- 1) If \overline{OE} is disabled at the same time or before \overline{CE} is disabled, the output will go to high-z by tOEZ.
 If \overline{CE} is disabled at the same time or before \overline{OE} is disabled, the output will go to high-z by tCEZ.
 If \overline{CE} and \overline{OE} are disabled at the same time, the output will go to high-z by tOEZ.
 These parameters are not 100% tested.

5.6 AC Characteristics for Warm Reset (\overline{RP}), Hot Reset and NAND Flash Core Reset

See Timing Diagrams 6.17, 6.18 and 6.19

Parameter	Symbol	Min	Max	Unit
\overline{RP} & Reset Command Latch to BootRAM Access	tReady1 (BufferRAM)	-	5	μ s
\overline{RP} & Reset Command Latch(During Load Routines) to INT High (Note1)	tReady2 (NAND Flash Array)	-	10	μ s
\overline{RP} & Reset Command Latch(During Program Routines) to INT High (Note1)	tReady2 (NAND Flash Array)	-	20	μ s
\overline{RP} & Reset Command Latch(During Erase Routines) to INT High (Note1)	tReady2 (NAND Flash Array)	-	150	μ s
\overline{RP} & Reset Command Latch(NOT During Internal Routines) to INT High (Note1)	tReady2 (NAND Flash Array)	-	10	μ s
\overline{RP} Pulse Width (Note2)	tRP	200	-	ns

NOTE :

- 1) These parameters are tested based on INT bit of interrupt register. Because the time on INT pin is related to the pull-up and pull-down resistor value.
- 2) The device may reset if tRP < tRP min(200ns), but this is not guaranteed.

5.7 AC Characteristics for Asynchronous Write

See Timing Diagrams 6.7

Parameter	Symbol	Min	Max	Unit
\overline{WE} Cycle Time	t _{WC}	70	-	ns
\overline{AVD} low pulse width	t _{AVDP}	12	-	ns
Address Setup Time	t _{AWES}	0	-	ns
Address Hold Time	t _{AH}	30	-	ns
Data Setup Time	t _{DS}	25	-	ns
Data Hold Time	t _{DH}	0	-	ns
\overline{CE} Setup Time	t _{CS}	0	-	ns
\overline{CE} Hold Time	t _{CH}	0	-	ns
\overline{WE} Pulse Width	t _{WPL}	40	-	ns
\overline{WE} Pulse Width High	t _{WPH}	30	-	ns
\overline{WE} Disable to \overline{AVD} Enable	t _{WEA}	15	-	ns
\overline{CE} Disable to Output & RDY High Z	t _{CEZ}	-	20	ns

5.8 AC Characteristics for Burst Write Operation (1.8V only)

See Timing Diagrams 6.8 and 6.9.

Parameter	Symbol	66MHz		83MHz		Unit
		Min	Max	Min	Max	
Clock	CLK ¹⁾	1	66	1	83	MHz
Clock Cycle	t _{CLK}	15	-	12	-	ns
\overline{AVD} Setup to CLK	t _{AVDS}	5	-	4	-	ns
\overline{AVD} Hold Time from CLK	t _{AVDH}	2	-	2	-	ns
Address Setup Time to CLK	t _{ACS}	5	-	4	-	ns
Address Hold Time from CLK	t _{ACH}	6	-	6	-	ns
Data Setup Time to CLK	t _{WDS}	5	-	4	-	ns
Data Hold Time from CLK	t _{WDH}	2	-	2	-	ns
\overline{WE} Setup Time to CLK	t _{WES}	5	-	4	-	ns
\overline{WE} Hold Time from CLK	t _{WEH}	6	-	6	-	ns
CLK High or Low Time	t _{CLKH/L}	t _{CLK} /3	-	5	-	ns
\overline{CE} high pulse width	t _{CEHP}	10	-	10	-	ns
CLK to RDY Valid	t _{RDYO}	-	11	-	9	ns
CLK to RDY Setup Time	t _{RDYA}	-	11	-	9	ns
RDY Setup Time to CLK	t _{RDYS}	4	-	3	-	ns
\overline{CE} low to RDY valid	t _{CER}	-	15	-	15	ns
Clock to \overline{CE} disable	t _{CEH}	2	t _{CLK} -4.5	2	t _{CLK} -4.5	ns
\overline{CE} Setup Time to CLK	t _{CES}	6	-	4.5	-	ns
\overline{CE} Disable to Output & RDY High Z	t _{CEZ}	-	20	-	20	ns

5.9 AC Characteristics for Load/Program/Erase Performance

See Timing Diagrams 6.10, 6.11, 6.12, 6.13, 6.14 and 6.15

Parameter	Symbol	Min	Typ	Max	Unit	
SECTOR LOAD TIME(NOTE 1)	tRD1	SLC	-	25	75	ms
		MLC		30	100	ms
PAGE LOAD TIME(NOTE 1)	tRD2	SLC	-	45	400	ms
		MLC	-	50	420	ms
PAGE PROGRAM TIME(NOTE 1)	tPGM2	SLC	-	240	770	ms
		MLC		1000	5000	ms
OTP ACCESS TIME(NOTE 1)	tOTP	-	500	700	ns	
LOCK/UNLOCK/LOCK-TIGHT(NOTE 1)	tLOCK	-	500	700	ns	
ALL BLOCK UNLOCK TIME(NOTE 1)	tABU	-	2	3	ms	
ERASE SUSPEND TIME(NOTE 1)	tESP	-	400	500	ms	
ERASE RESUME TIME(NOTE 1)	tERS1	-	0.5	11	ms	
NUMBER OF PARTIAL PROGRAM CYCLES IN THE PAGE (INCLUDING MAIN AND SPARE AREA)	NOP	SLC	-	-	1	cycles
		MLC	-	-	1	cycles
BLOCK ERASE TIME (NOTE 1)	tBERS1	-	0.5	11	ms	

NOTE :

1) These parameters are tested based on INT bit of interrupt register. Because the time on INT pin is related to the pull-up and pull-down resistor value.

5.10 AC Characteristics for INT Auto Mode

See Timing Diagrams 6.21

Parameter	Symbol	Min	Max	Unit
Command Input to INT Low	t _{WB}	-	200	ns

6.0 TIMING DIAGRAMS

6.1 8-Word Linear Burst Read Mode with Wrap Around

See AC Characteristics Table 5.4

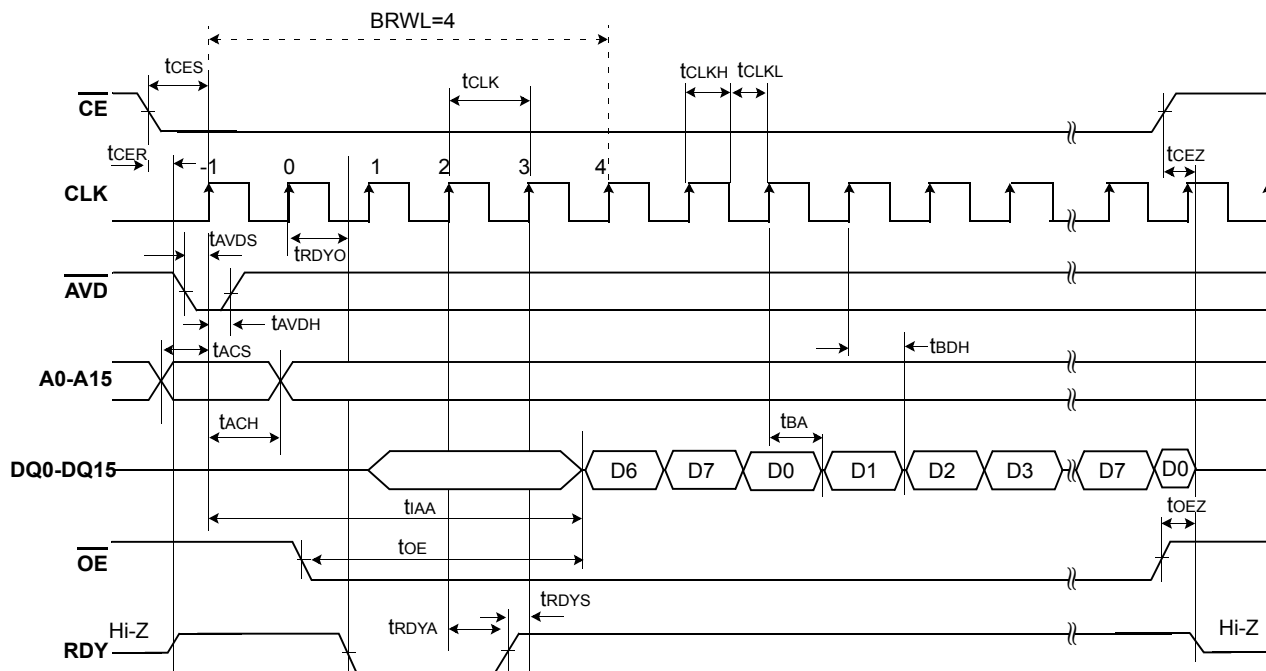

6.2 Continuous Linear Burst Read Mode with Wrap Around

See AC Characteristics Table 5.4

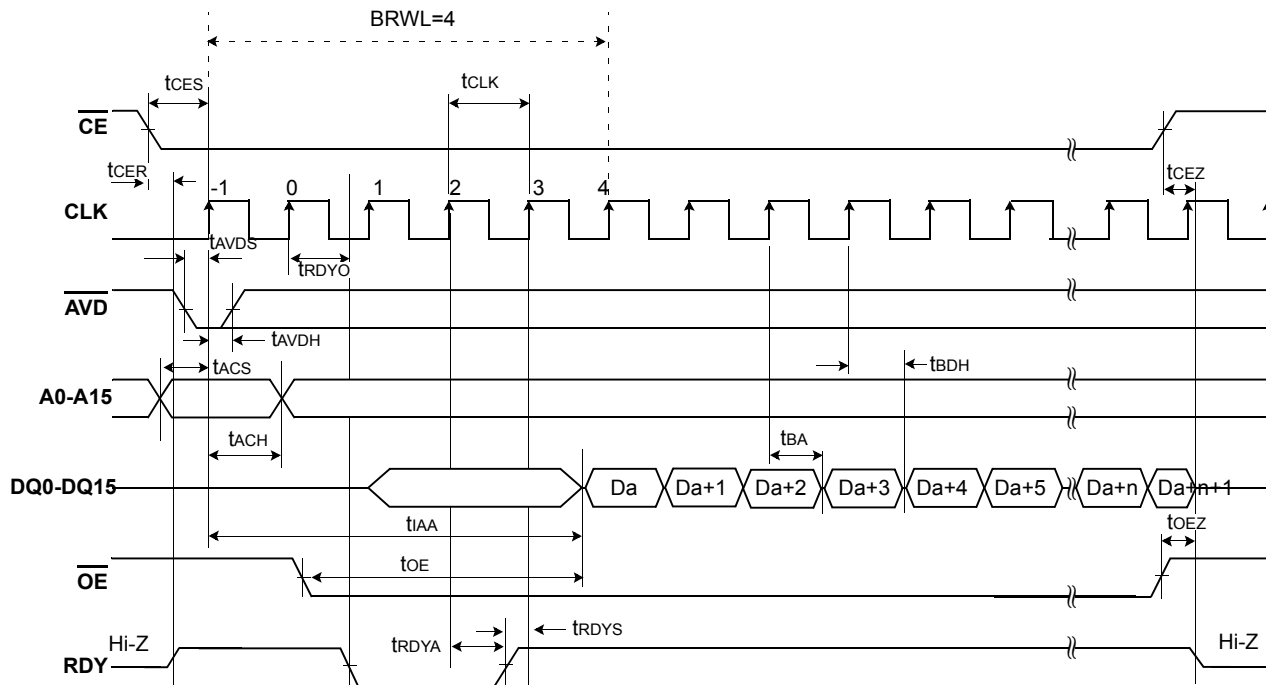

6.3 Asynchronous Read (VA Transition Before $\overline{\text{AVD}}$ Low)

See AC Characteristics Table 5.5

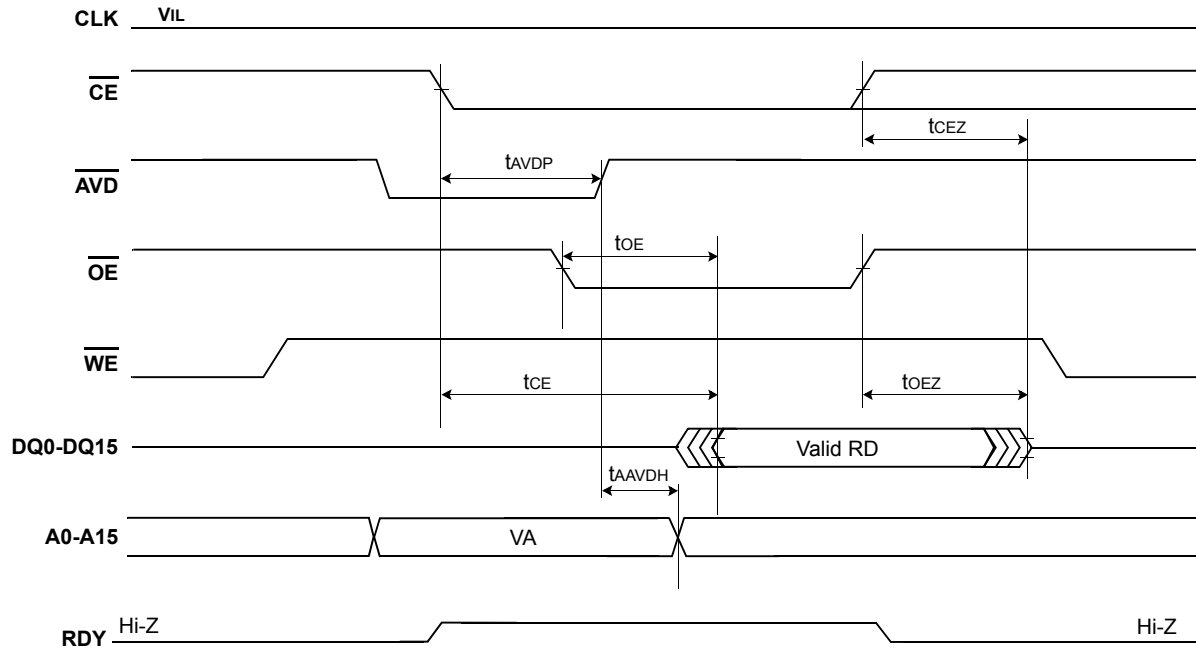

NOTE :
 VA=Valid Read Address, RD=Read Data.

6.4 Asynchronous Read (VA Transition After $\overline{\text{AVD}}$ Low)

See AC Characteristics Table 5.5

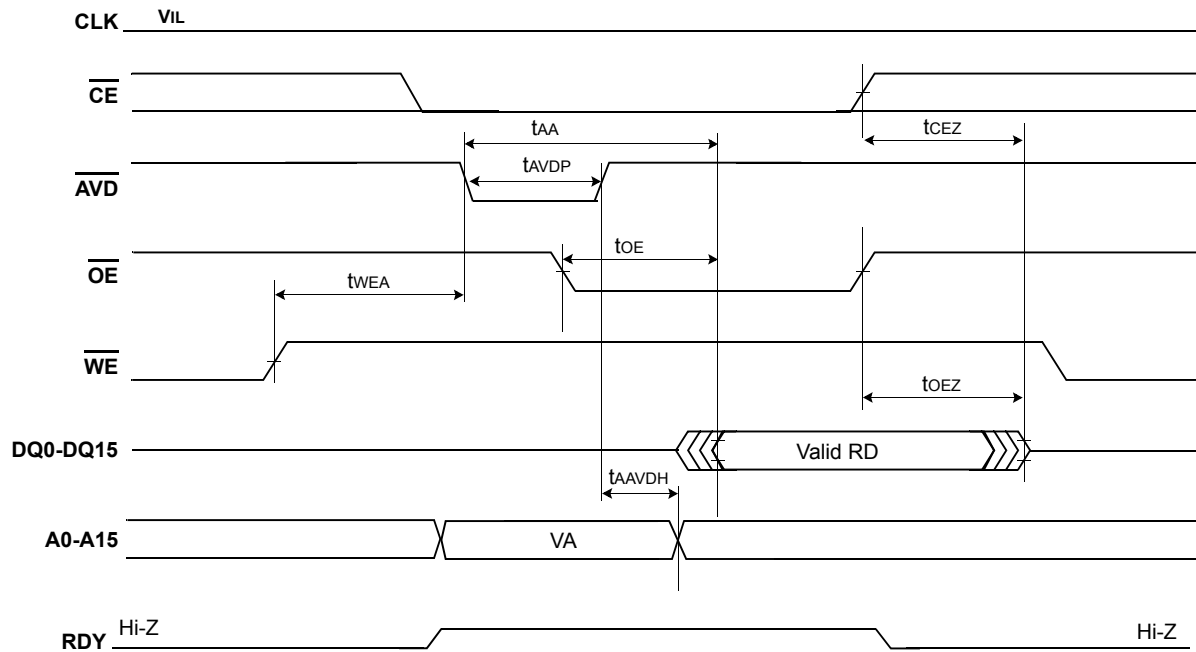

NOTE :
 VA=Valid Read Address, RD=Read Data.

6.5 Asynchronous Read (VA and $\overline{\text{AVD}}$ Transition After $\overline{\text{CE}}$ Low)

See AC Characteristics Table 5.5

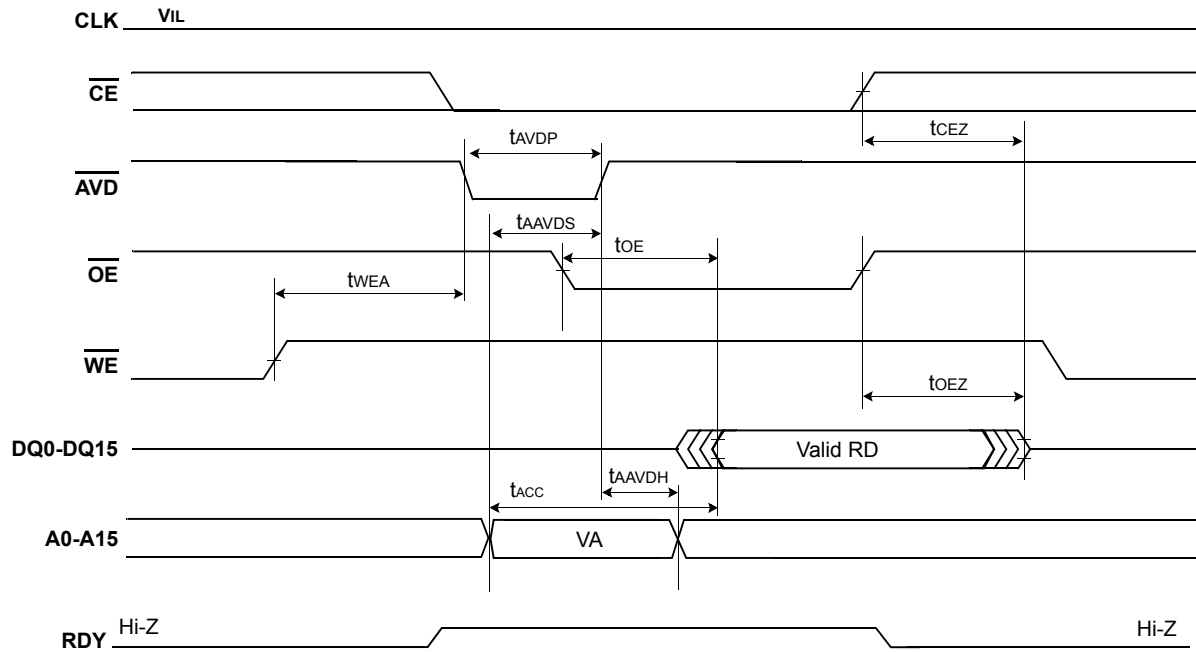

NOTE :
 VA=Valid Read Address, RD=Read Data.

6.6 Asynchronous Read ($\overline{\text{AVD}}$ is tied to $\overline{\text{CE}}$)

See AC Characteristics Table 5.5

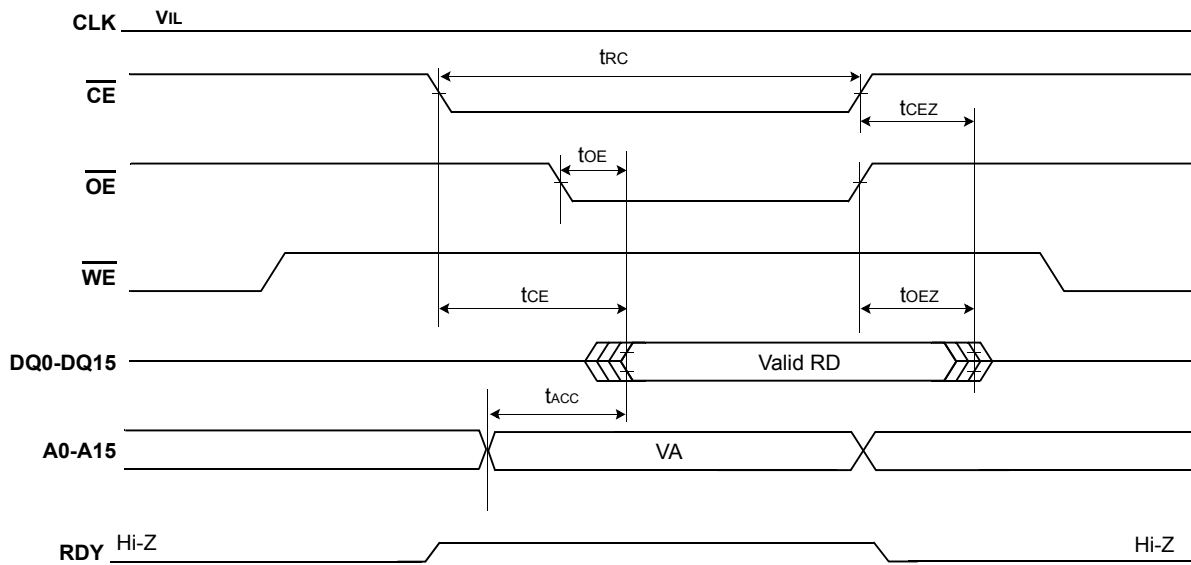

NOTE :
 VA=Valid Read Address, RD=Read Data.

6.7 Asynchronous Write

See AC Characteristics Table 5.7

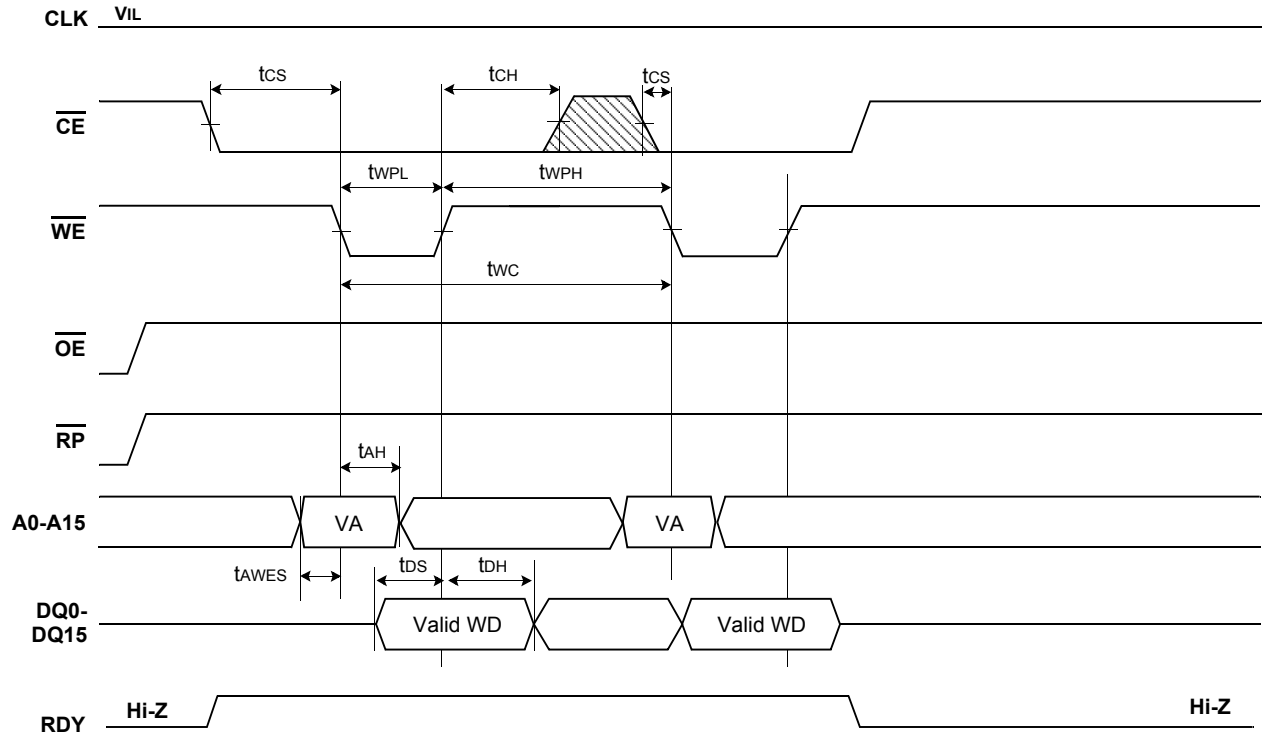

NOTE :
 VA=Valid Read Address, WD=Write Data.

6.8 8-Word Linear Burst Write Mode (1.8V only)

See AC Characteristics Table 5.8

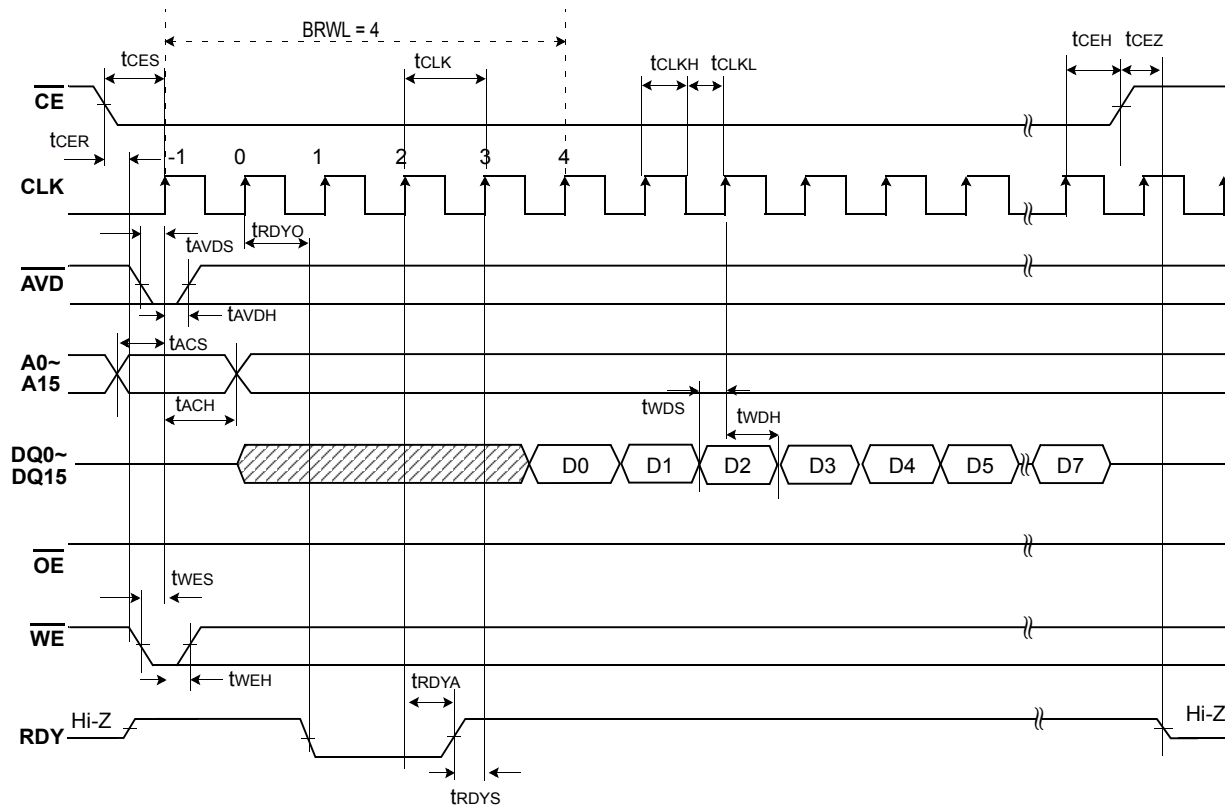

6.9 Start Initial Burst Write Operation (1.8V only)

See AC Characteristics Table 5.8

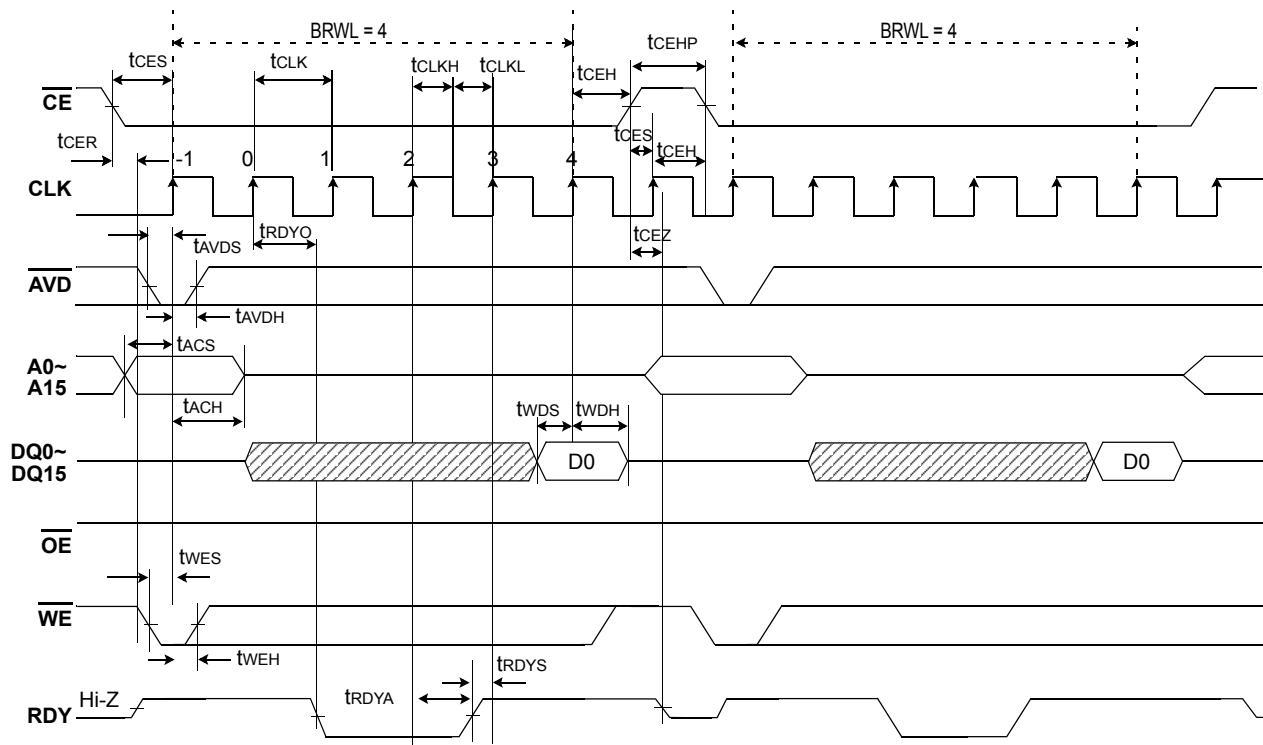

6.10 Load Operation Timing

See AC Characteristics Table 5.7 and Table 5.9

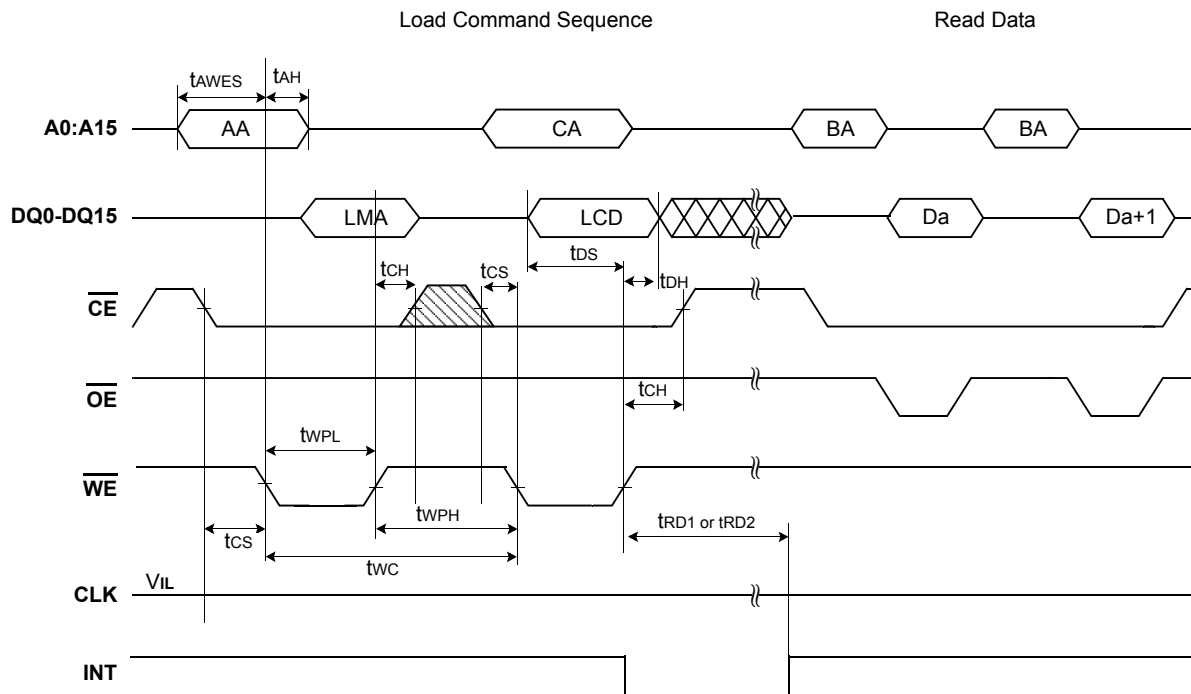

NOTE :

- 1) AA = Address of address register
 CA = Address of command register
 LCD = Load Command
 LMA = Address of memory to be loaded
 BA = Address of BufferRAM to load the data
 BD = Program Data
 SA = Address of status register
- 2) "In progress" and "complete" refer to status register
- 3) Status reads in this figure is asynchronous read, but status read in synchronous mode is also supported.

6.11 Superload Operation Timing

See AC Characteristics Table 5.7 and Table 5.9

Superload Operation Timing Diagram

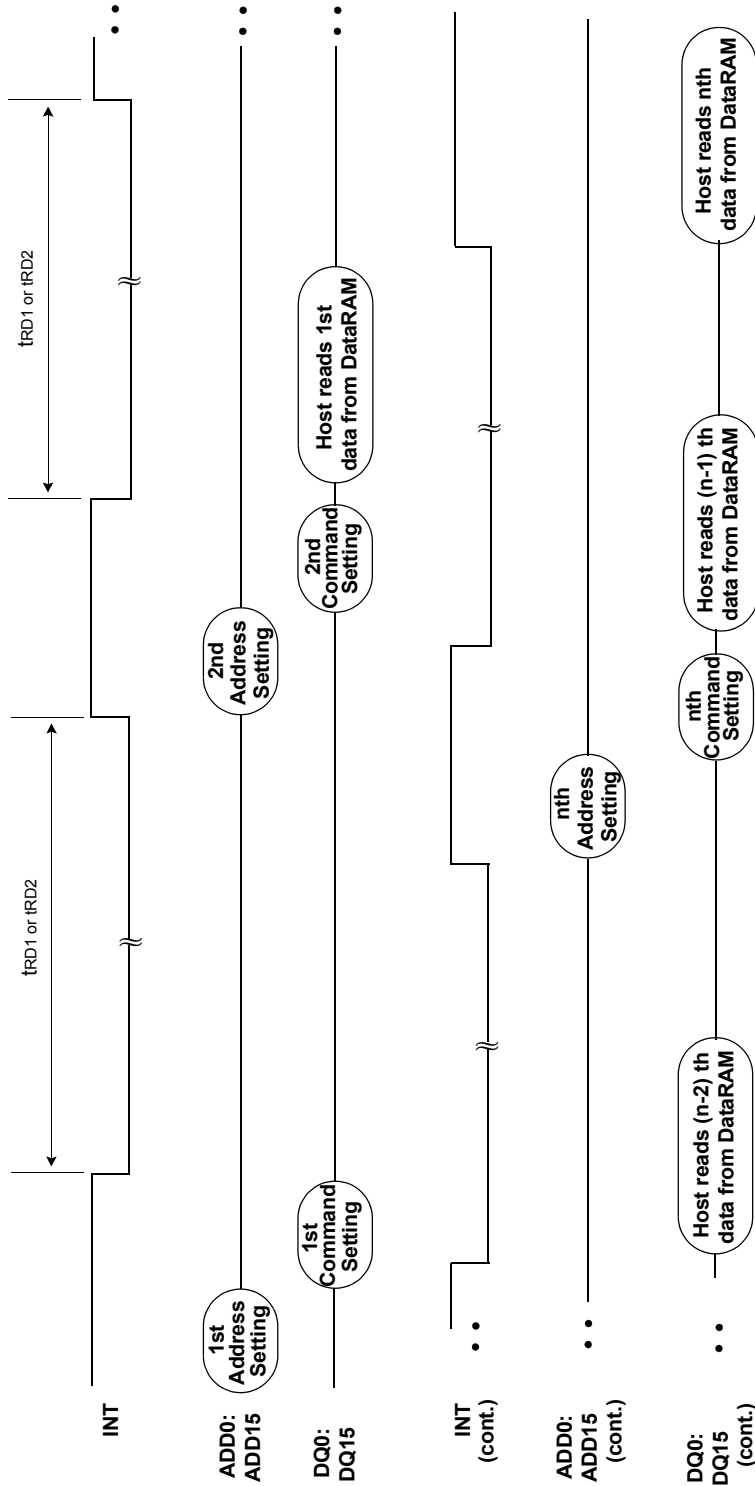

- 1st~nth Address Setting : Address Setting Operation for first page load(DFS, FBA, DBS and FPA).
- 1st Command Setting : 0000h, 2nd~nth Command Setting : 0003h
(In INT auto mode, writing 0 to interrupt register may be ignored)
- In case of page transfer, sensing time is tRD2, in case of sector transfer, sensing time is tRD1.
- Host read 1st~nth data from DataRAM : Host can read data from DataRAM only synchronous read mode.

6.12 Program Operation Timing

See AC Characteristics Table 5.7 and Table 5.9

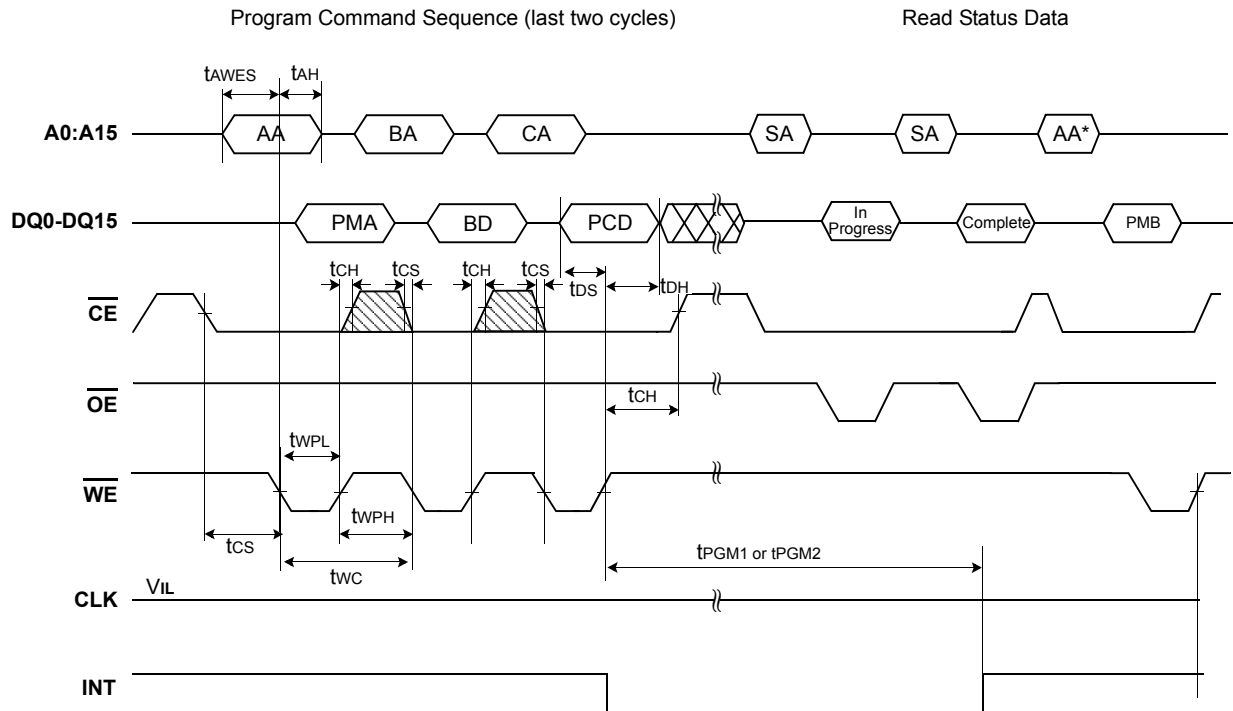

NOTE :

- 1) AA = Address of address register
 CA = Address of command register
 PCD = Program Command
 PMA = Address of memory to be programmed
 BA = Address of BufferRAM to load the data
 BD = Program Data
 SA = Address of status register
 AA* = Address of Start Address1 Register(for Flash Block Address)
 PMB = DFS & FBA(Flash Block address) of memory to be programmed next time
- 2) "In progress" and "complete" refer to status register
- 3) Status reads in this figure is asynchronous read, but status read in synchronous mode is also supported.

6.13 Cache Program Operation Timing (1.8V only)

See AC Characteristics Table 5.7 and Table 5.9

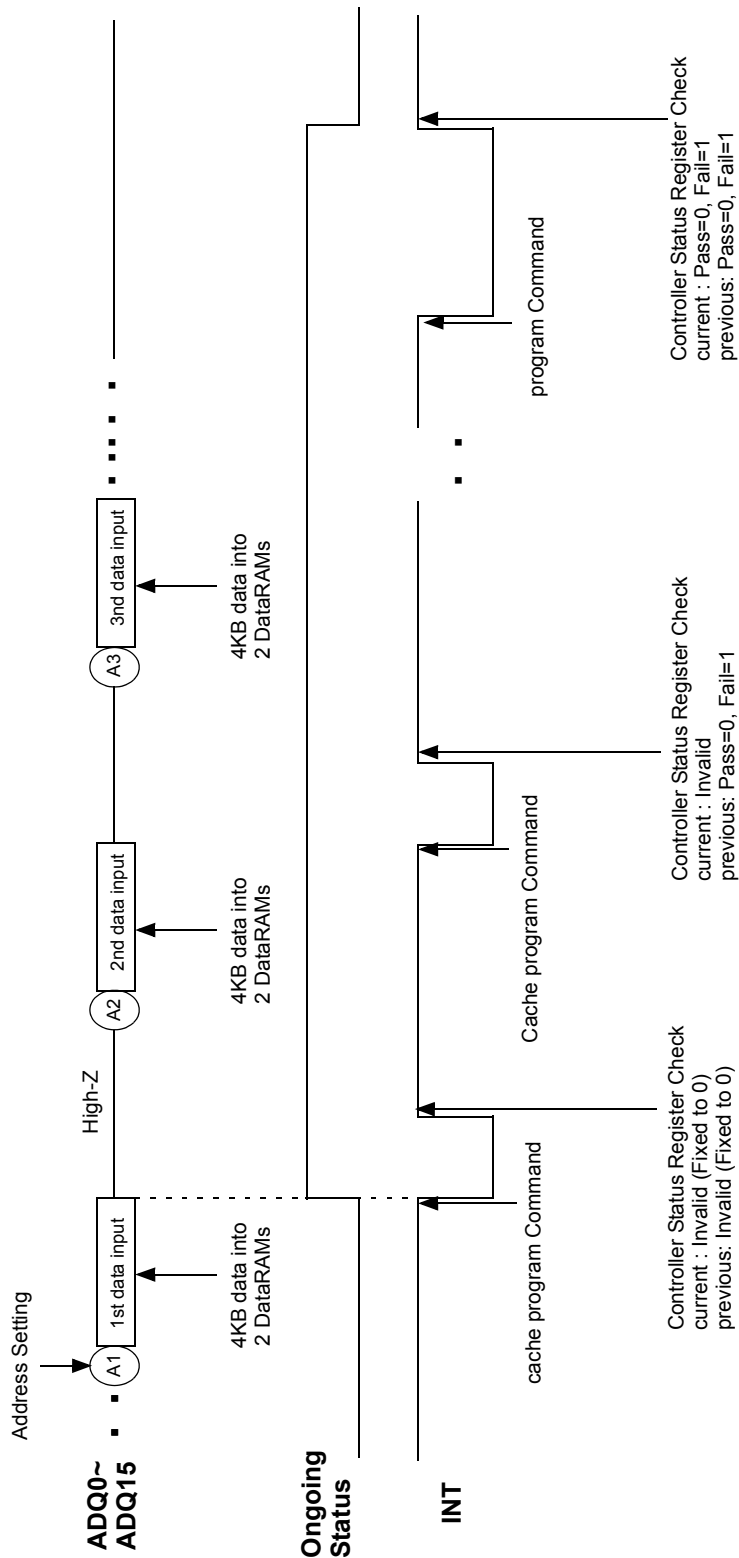

A1, A2, A3 : Address of DataRAM to be written
 INT: Indicator for DataRAM's Status (Ready=High, Busy=Low)
 Ongoing Status : Indicated by OnGo bit in Controller Status Register [15] (F240h)
 4KB data input : Asynch Write / Synch Write available.
 Command input and INT pin behavior is based on 'INT auto mode'.
 In 'INT manual mode', writing '0' to interrupt register is required before command issue.

6.14 Interleave Cache Program Operation Timing (1.8V only)

See AC Characteristics Table 5.7 and Table 5.9

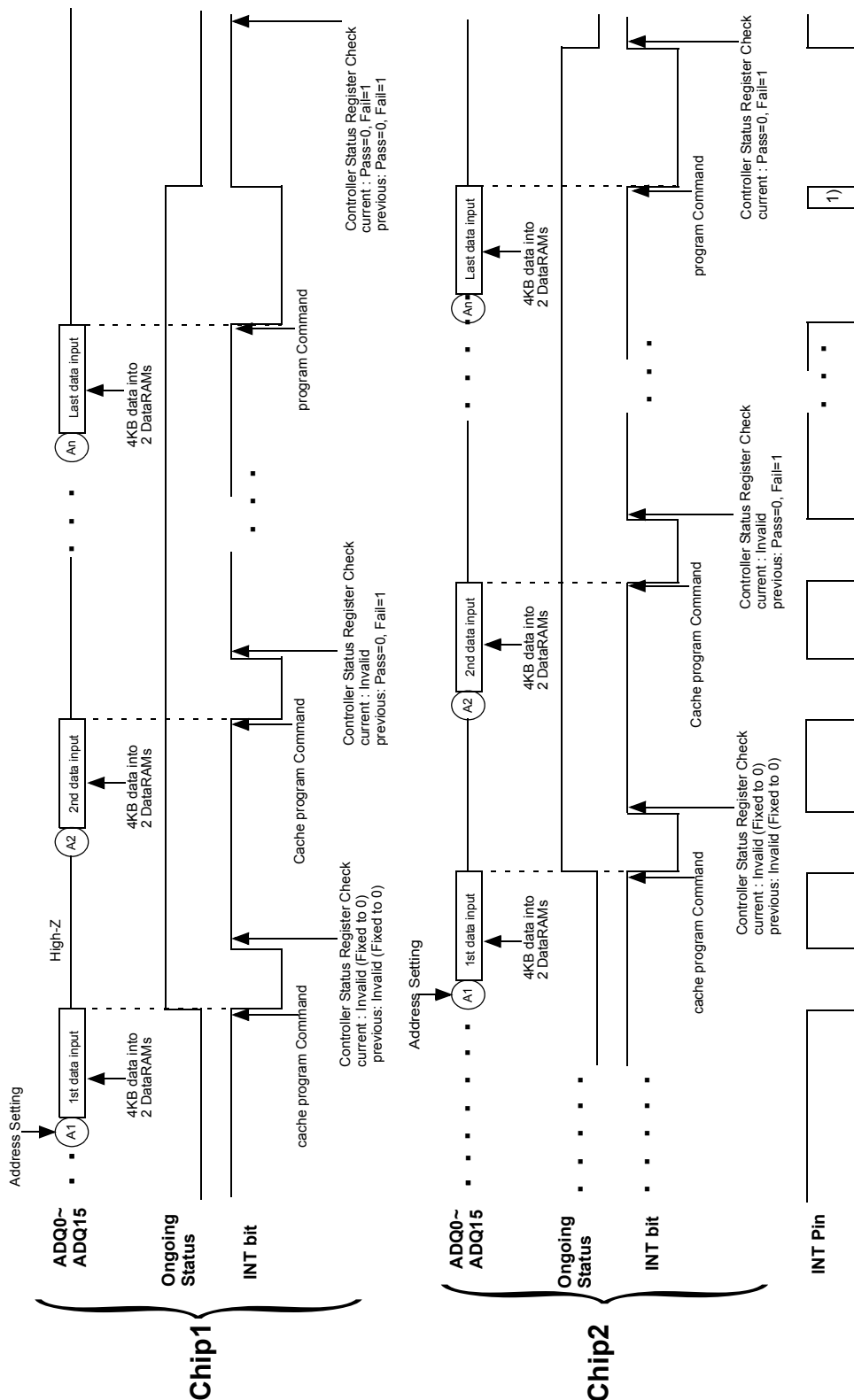

A1, A2, An : Address of DataRAM to be written.
 INT: Indicator for DataRAM's Status (Ready=High, Busy=Low)
 Ongoing Status : Indicated by OnGo bit in Controller Status Register [15] (F240h)
 4KB data input : Asynch Write / Synchron Write available.
 Command input and INT bit or pin behavior is based on 'INT auto mode'.

NOTE:

INT pin might toggle when INT bit of chip1 turns to ready before host issues 'program' command on chip2.

6.15 Block Erase Operation Timing

See AC Characteristics Table 5.7 and Table 5.9

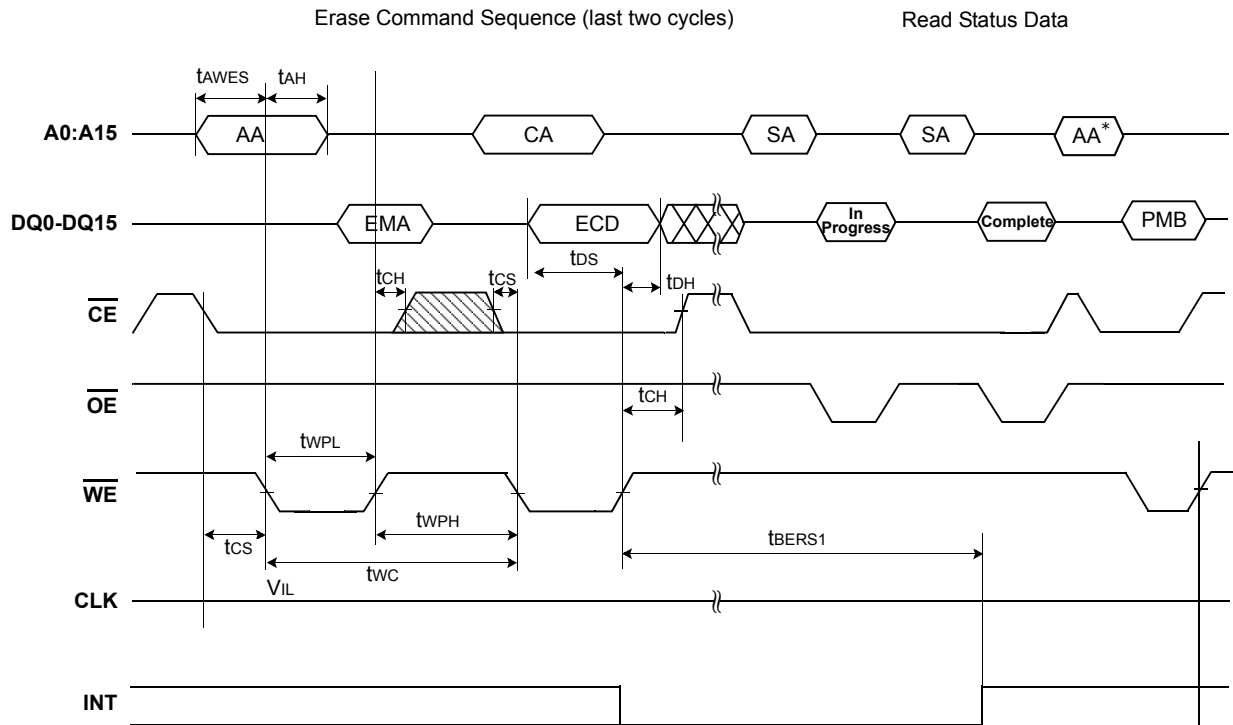

NOTE :

- 1) AA = Address of address register
 CA = Address of command register
 ECD = Erase Command
 EMA = Address of memory to be erased
 SA = Address of status register
 AA* = Address of Start Address1 Register(for Flash Block Address)
 PMB = DFS & FBA(Flash Block address) of memory to be programmed next time
- 2) "In progress" and "complete" refer to status register
- 3) Status reads in this figure is asynchronous read, but status read in synchronous mode is also supported.

6.16 Cold Reset Timing

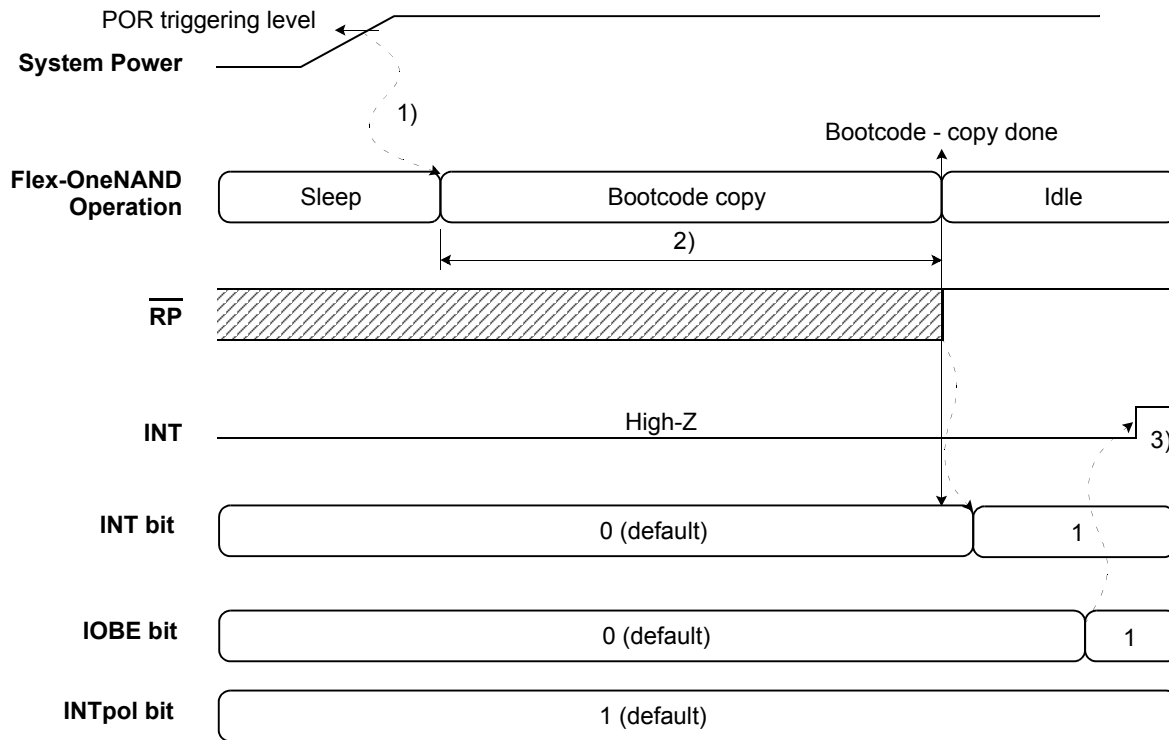

NOTE :

- 1) Bootcode copy operation starts 400us later than POR activation.
 The system power should reach Vcc after POR triggering level (typ. 1.5V@1.8V, typ. 1.8V@3.3V) within 400us for valid boot code data.
- 2) 1KB Bootcode copy and internal update operation take 250us (estimated) from sector0 and 1/page0/block0 of NAND Flash array to BootRAM.
 Host can read Bootcode in BootRAM (1K bytes) after Bootcode copy completion.
- 3) INT register goes 'Low' to 'High' on the condition of 'Bootcode-copy done' and RP rising edge.
 If RP goes 'Low' to 'High' before 'Bootcode-copy done', INT register goes to 'Low' to 'High' as soon as 'Bootcode-copy done'

6.17 Warm Reset Timing

See AC Characteristics Table 5.6

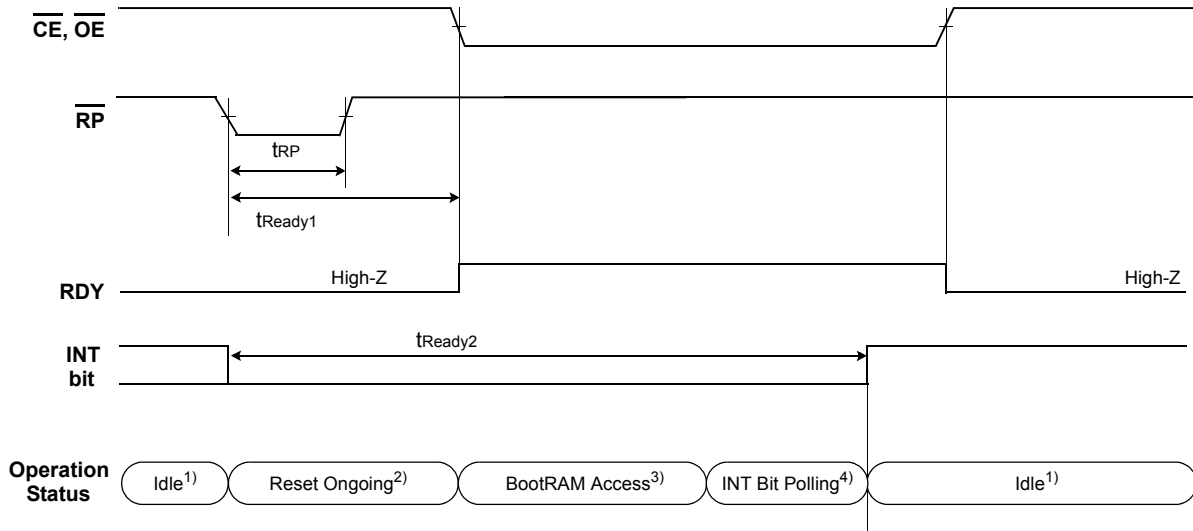

NOTE :

- 1) The status which can accept any register based operation(Load, Program, Erase command, etc).
- 2) The status where reset is ongoing.
- 3) The status allows only BootRAM(BL1) read operation for Boot Sequence.(Refer to 7.2.2 Boot Sequence)
- 4) To read BL2 of Boot Sequence, Host should wait INT until becomes ready. and then, Host can issue load command.
 (Refer to 7.2.2 Boot Sequence, 7.1 Methods of Determining Interrupt status)

6.18 Hot Reset Timing

See AC Characteristics Table 5.6

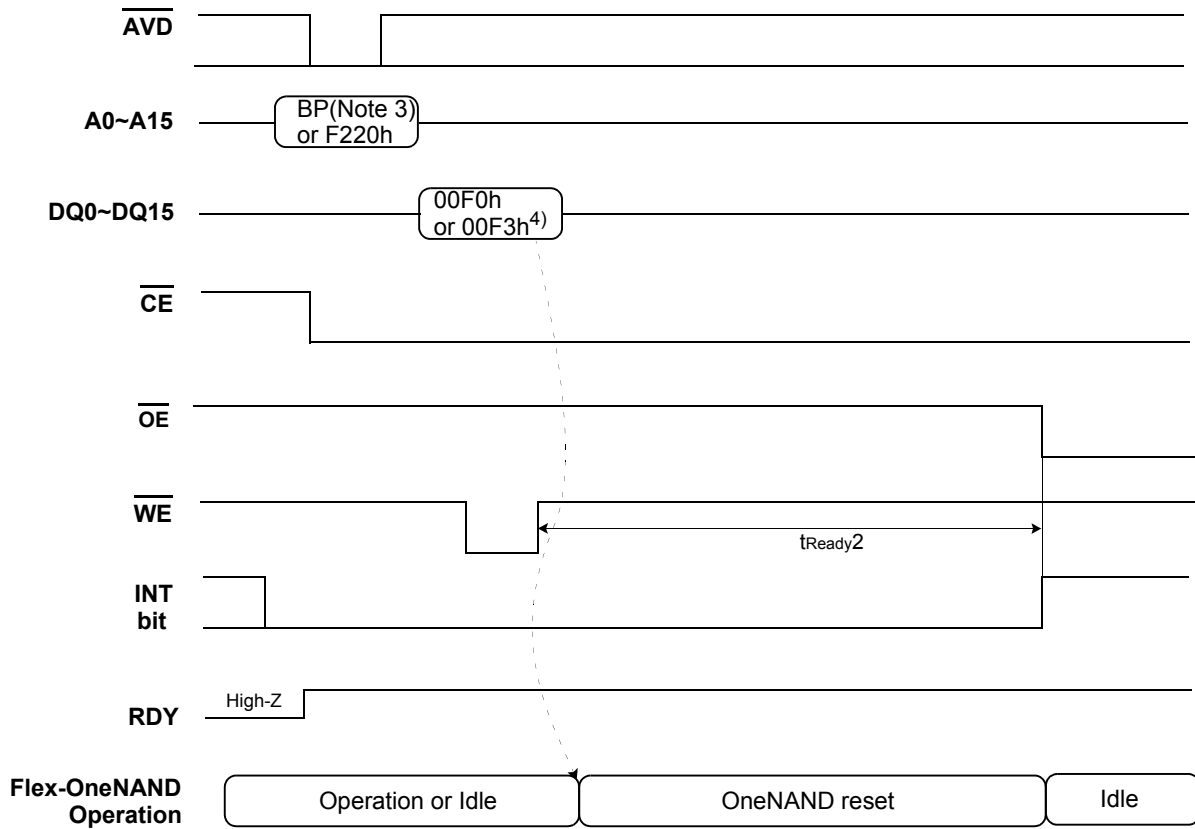

NOTE :

- 1) Internal reset operation means that the device initializes internal registers and makes output signals go to default status and bufferRAM data are kept unchanged after Warm/Hot reset operations.
- 2) Reset command : Command based reset or Register based reset
- 3) BP(Boot Partition): BootRAM area [0000h~01FFh, 8000h~800Fh]
- 4) 00F0h for BP, and 00F3h for F220h

6.19 NAND Flash Core Reset Timing

See AC Characteristics Table 5.6

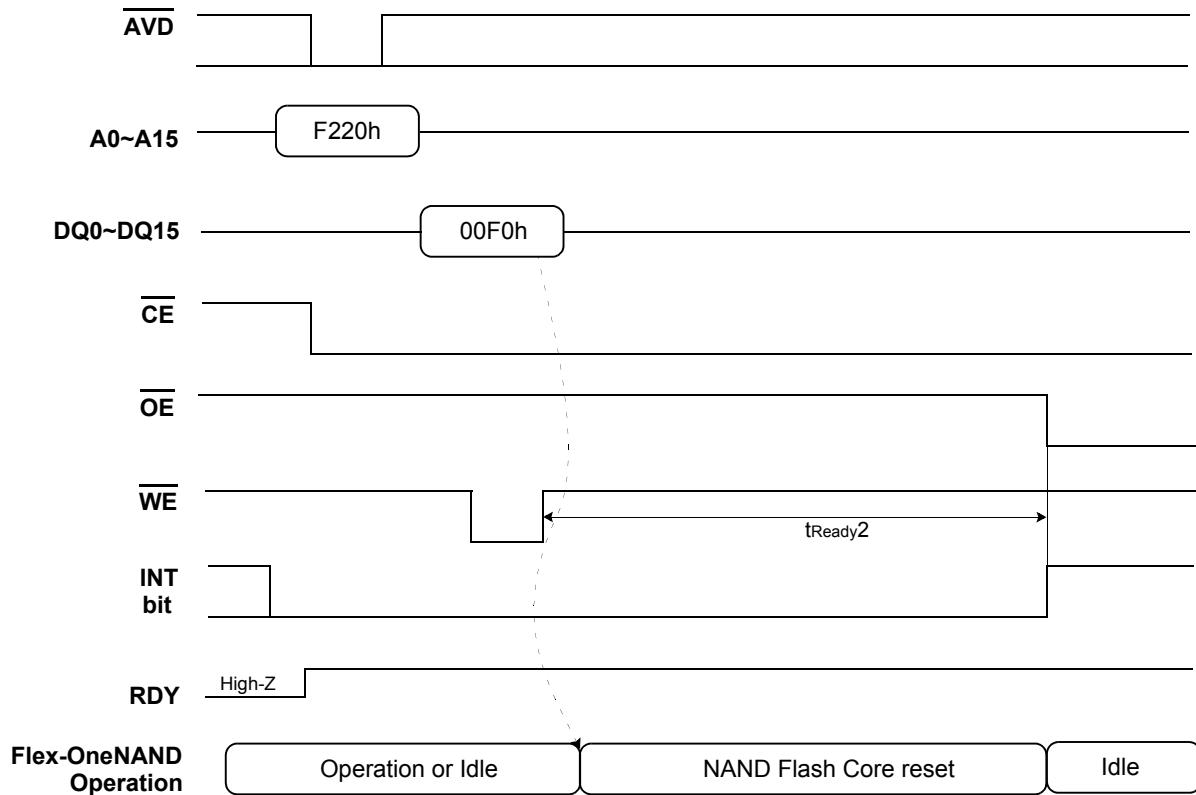

6.20 Data Protection Timing During Power Down

The device is designed to offer protection from any involuntary program/erase during power-transitions. \overline{RP} pin provides hardware protection and is recommended to be kept at V_{IL} before V_{cc} drops to 1.5V(@1.8V), 1.8V(@3.3V).

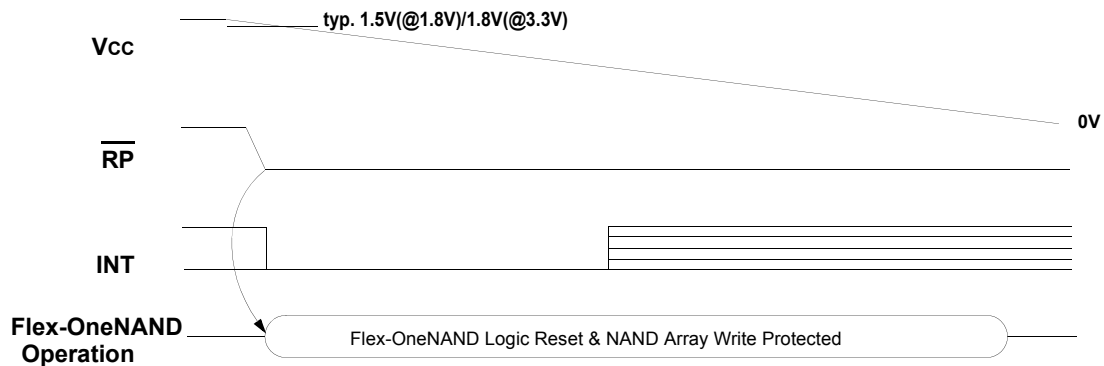

6.21 INT auto mode

See AC Characteristics Table 5.10.

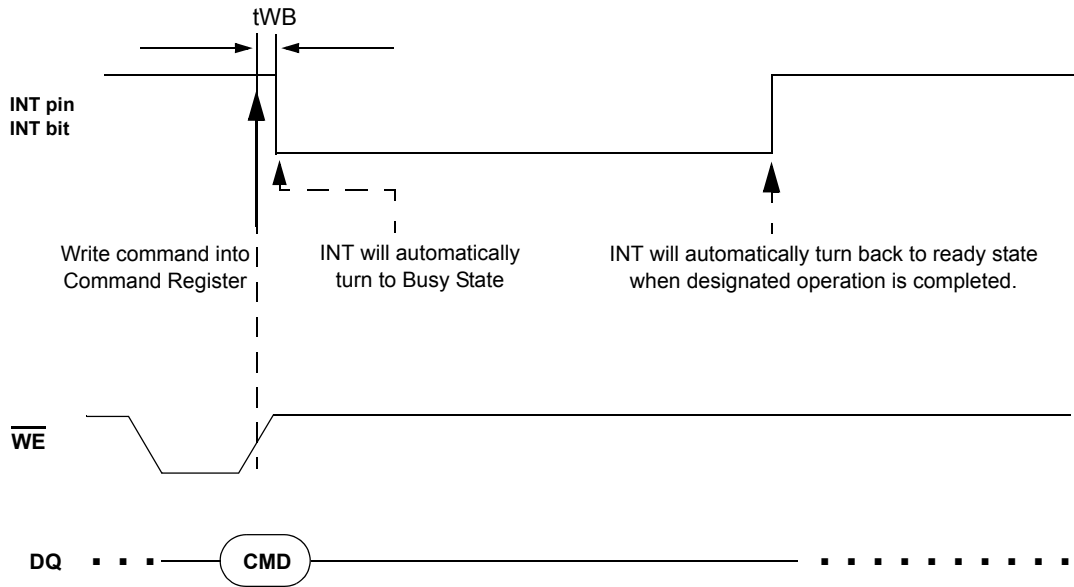

NOTE :

1) INT pin polarity is based on 'IOBE=1 and INT pol=1 (default)' setting

7.0 TECHNICAL AND APPLICATION NOTES

From time-to-time supplemental technical information and application notes pertaining to the design and operation of the device in a system are included in this section. Contact your Samsung Representative to determine if additional notes are available.

7.1 Methods of Determining Interrupt Status

There are two methods of determining Interrupt Status on the Flex-OneNAND. Using the INT pin or monitoring the Interrupt Status Register Bit.

The Flex-OneNAND INT pin is an output pin function used to notify the Host when a command has been completed. This provides a hardware method of signaling the completion of a program, erase, or load operation.

In its normal state, the INT pin is high if the INT polarity bit is default. In case of normal INT mode, before a command is written to the command register, the INT bit must be written to '0' for the INT pin transitions to a low state indicating start of the operation. In case of 'INT auto mode', INT bit is written to '0' automatically right after command issued. Upon completion of the command operation by the Flex-OneNAND's internal controller, INT returns to a high state.

INT pin is a DQ-type output except 'Reset' and 'Interleave Cache program' in DDP allowing two INT outputs to be Or-tied together. In case of 'Reset' and 'Interleave Cache Program' in DDP, INT pin operates as an open drain with 50K ohm. INT is an INT does not float to a hi-Z condition when \overline{CE} is disabled or \overline{OE} is disabled. Refer to section 2.8 for additional information about INT.

INT can be implemented by tying INT to a host GPIO or by continuous polling of the Interrupt status register.

	INT Type (Mono)	INT Type (DDP)
General Operation	DQ type	DQ type
Reset Operation (Cold,Warm,Hot and Flash Core Reset) and final command of Interleave cache program	DQ type	Open drain (with 50K ohm)

7.1.1 The INT Pin to a Host General Purpose I/O

INT can be tied to a Host GPIO to detect the rising edge of INT, signaling the end of a command operation.

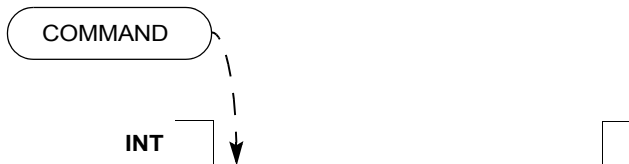

This can be configured to operate either synchronously or asynchronously as shown in the diagrams below.

Synchronous Mode Using the INT Pin

When operating synchronously, INT is tied directly to a Host GPIO. RDY could be connected as one of following guides.

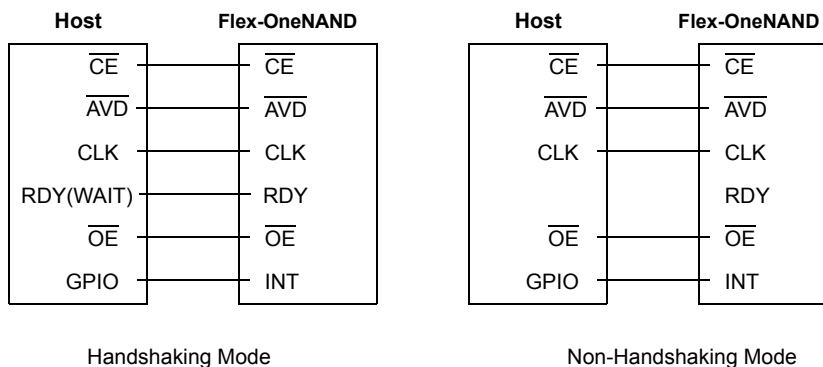

Asynchronous Mode Using the INT Pin

When configured to operate in an asynchronous mode, \overline{CE} , \overline{AVD} and \overline{OE} of the Flex-OneNAND are tied to corresponding pins of the Host. CLK is tied to the Host Vss (Ground). RDY is tied to a no-connect. \overline{OE} of the Flex-OneNAND and Host are tied together and INT is tied to a GPIO.

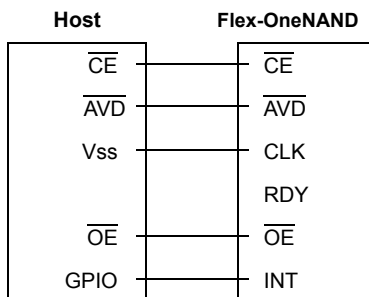

7.1.2 Polling the Interrupt Register Status Bit

An alternate method of determining the end of an operation is to continuously monitor the Interrupt Status Register Bit instead of using the INT pin.

When using interrupt register instead of INT pin, INT must be unconnected.

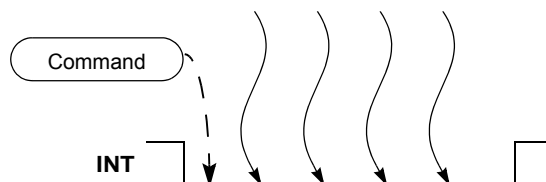

This can be configured in either a synchronous mode or an asynchronous mode.

Synchronous Mode Using Interrupt Status Register Bit Polling

When operating synchronously, \overline{CE} , \overline{AVD} , CLK, RDY, \overline{OE} , and DQ pins on the host and Flex-OneNAND are tied together. RDY could be connected as one of following guides.

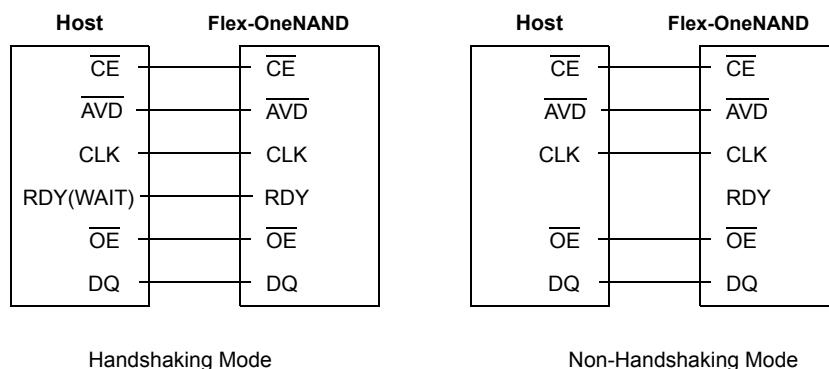

Asynchronous Mode Using Interrupt Status Register Bit Polling

When configured to operate in an asynchronous mode, \overline{CE} , \overline{AVD} , \overline{OE} and DQ of the Flex-OneNAND are tied to corresponding pins of the Host. CLK is tied to the Host Vss (Ground). RDY is NOT connected.

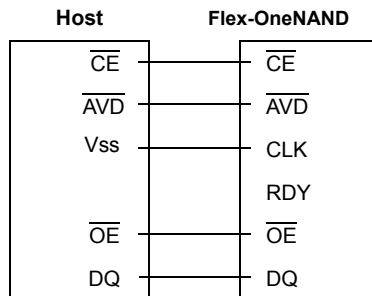

7.1.3 Determining Rp Value (DDP, QDP Only)

For general operation, INT operates as normal output pin, so that t_f is equivalent to t_r (below 10ns). But since INT operates as open drain with 50K ohm for Reset (Cold/Hot/Warm/NAND Flash Core) operations and 'Cache program operation' case at DDP option, the pull-up resistor value is related to $t_r(\text{INT})$. And appropriate value can be obtained with the following reference charts.

INT pol = 'High' (Default)

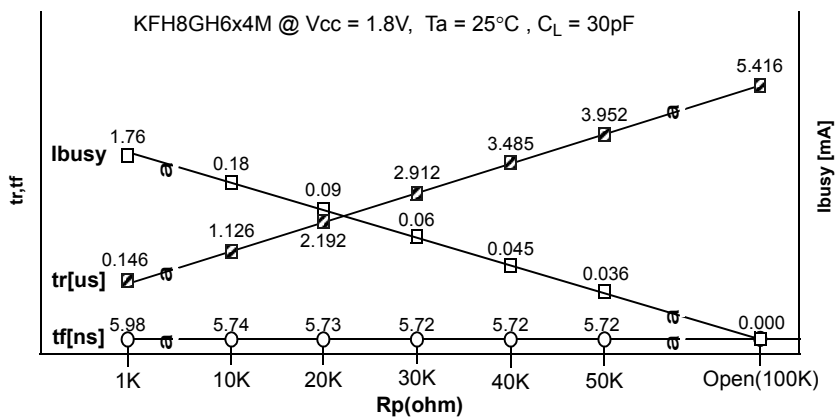
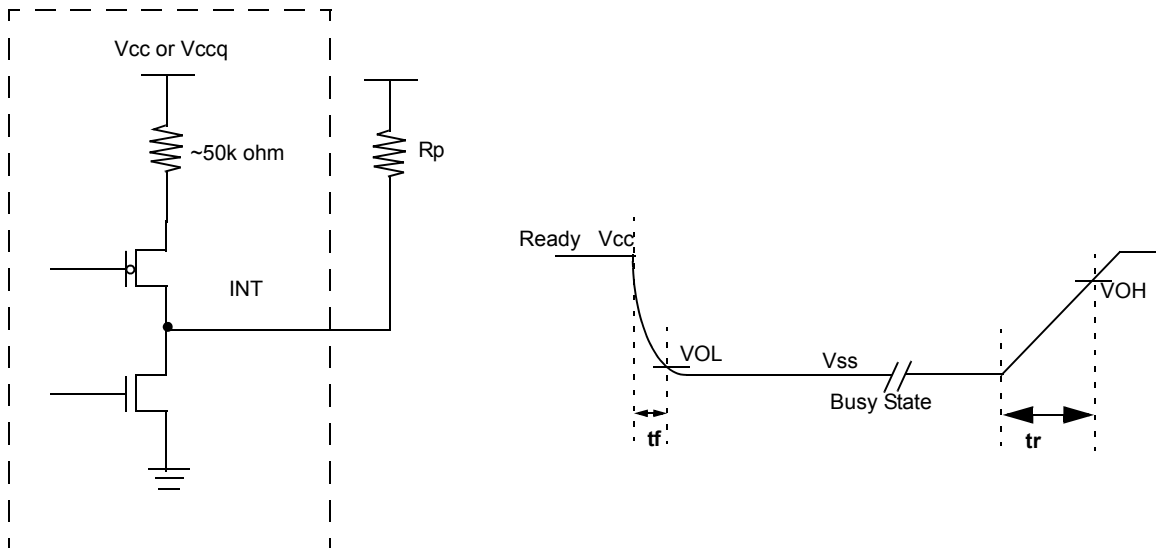

INT pol = 'Low'

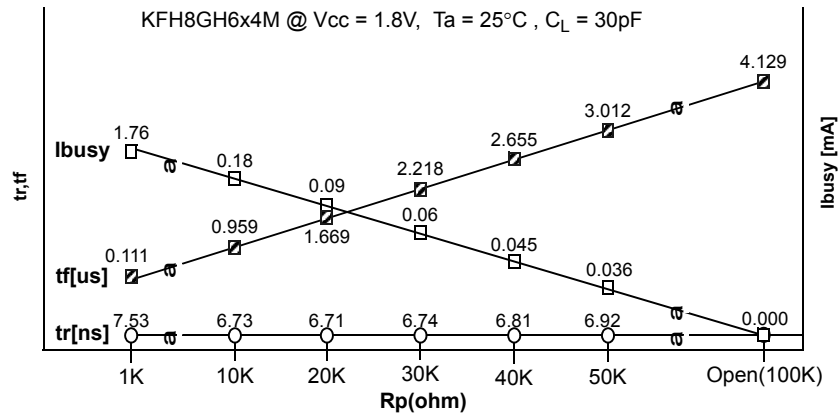
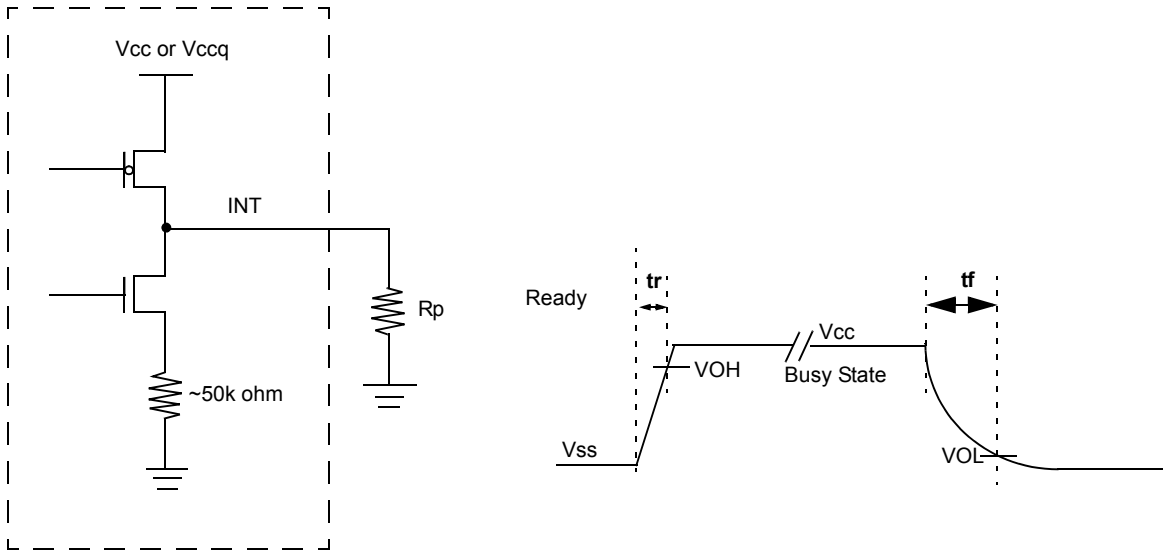

7.2 Boot Sequence

One of the best features Flex-OneNAND has is that it can be a booting device itself since it contains an internally built-in boot loader despite the fact that its core architecture is based on NAND Flash. Thus, Flex-OneNAND does not make any additional booting device necessary for a system, which imposes extra cost or area overhead on the overall system.

As the system power is turned on, the boot code originally stored in the first block which is SLC area is moved to BootRAM automatically and then fetched by CPU through the same interface as SRAM's or NOR Flash's if the size of the boot code is less than 1KB. If its size is larger than 1KB and less than or equal to 3KB, only 1KB of it can be moved to BootRAM automatically and fetched by CPU, and the rest of it can be loaded into one of the DataRAMs whose size is 2KB by Load Command and CPU can take it from the DataRAM after finishing the code-fetching job for BootRAM. If its size is larger than 3KB, the 1KB portion of it can be moved to BootRAM automatically and fetched by CPU, and its remaining part can be moved to DRAM through two DataRAMs and taken by CPU to reduce CPU fetch time.

A typical boot scheme usually used to boot the system with Flex-OneNAND is explained at Partition of NAND Flash Array and Flex-OneNAND Boot Sequence. In this boot scheme, boot code is comprised of BL1, where BL stands for Boot Loader, BL2, and BL3. Moreover, the size of the boot code is larger than 3KB (the 3rd case above). BL1 is called primary boot loader in other words. Here is the table of detailed explanations about the function of each boot loader in this specific boot scheme.

7.2.1 Boot Loaders in Flex-OneNAND

Boot Loaders in Flex-OneNAND

Boot Loader	Description
BL1	Moves BL2 from NAND Flash Array to DRAM through two DataRAMs
BL2	Moves OS image (or BL3 optionally) from NAND Flash Array to DRAM through two DataRAMs
BL3 (Optional)	Moves or writes the image through USB interface

NAND Flash Array of Flex-OneNAND is divided into the partitions as described at Partition of NAND Flash Array to show where each component of code is located and how much portion of the overall NAND Flash Array each one occupies. In addition, the boot sequence is listed below and depicted at Boot Sequence.

7.2.2 Boot Sequence

Boot Sequence :

1. Power is on
BL1 is loaded into BootRAM
2. BL1 is executed in BootRAM
BL2 is loaded into DRAM through two DataRAMs by BL1
3. BL2 is executed in DRAM
OS image is loaded into DRAM through two DataRAMs by BL2
4. OS is running

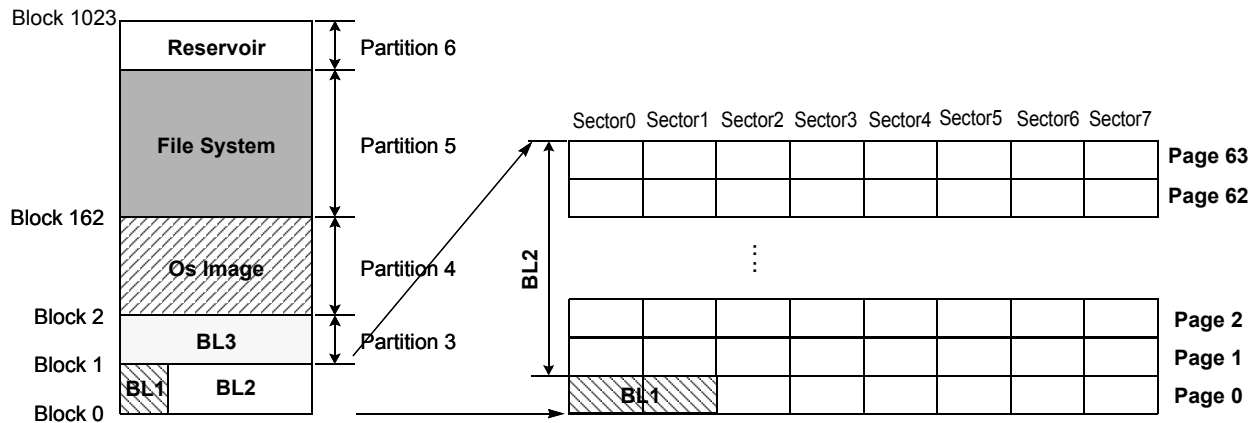

Partition of NAND Flash array

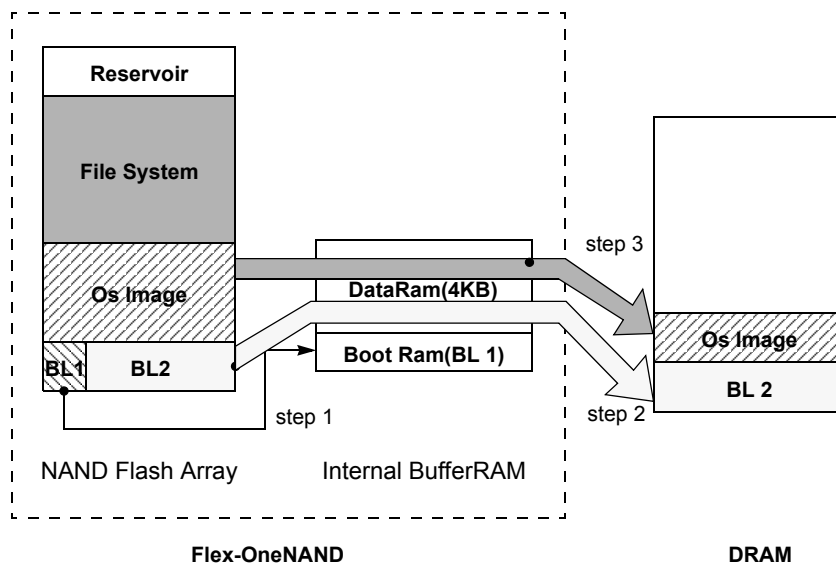

NOTE :

1) Step 2 and Step 3 can be copied into DRAM through two DataRAMs.

Flex-OneNAND Boot Sequence

7.3 Partition of Flex-OneNAND

Flex-OneNAND is the combo device which has SLC and MLC partition in one-chip. Generally, write intensive data require SLC-reliability but read and density oriented data such as music and movie satisfy with MLC-reliability. Therefore, some of the mobile phone is using both SLC-reliability memory and MLC-reliability memory to meet both requirements of reliability oriented and density oriented data using separate chip. but in case of Flex-OneNAND, only one-chip of Flex-OneNAND can meet the both requirement.

And also, Flex-OneNAND has internal Error Correction Circuit and common NOR interface. User can take full advantage of advances in NAND Flash memory capacity.

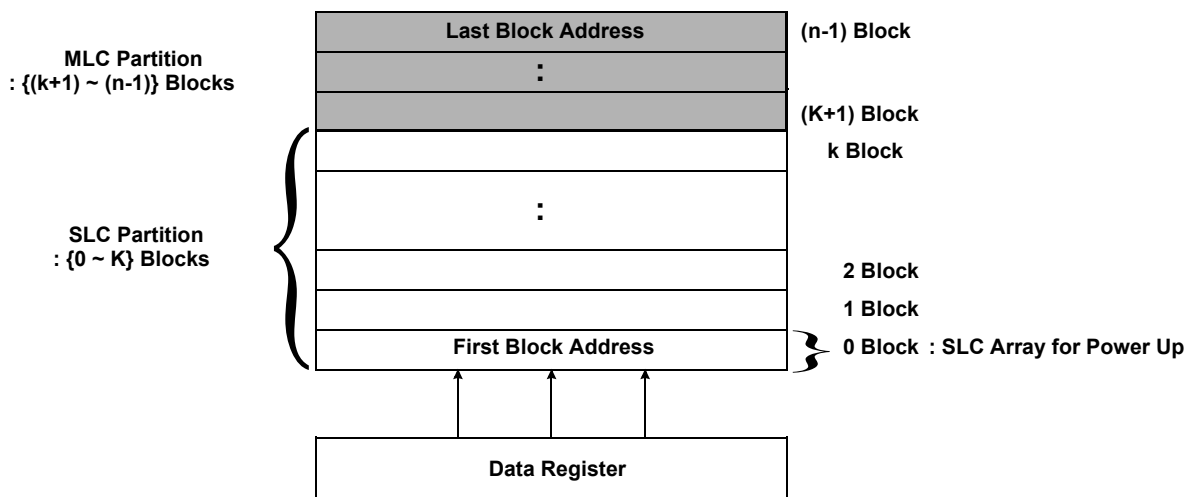

NOTE :

- 1) K is the boundary address(the end of SLC). Samsung will decide the value of K before final specification open (K=TBD).
- 2) For the partitioning method, samsung will support application note and guidance code.

7.4 DDP and QDP Description

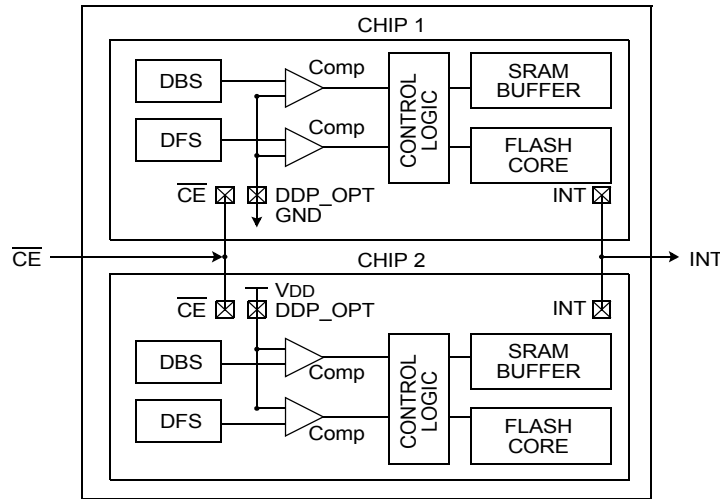

DDP(Dual Die Package):

8Gb DDP Flex-OneNAND contains two chips of 4Gb which are multiplexed such that they provide a single address range interface, with double the storage capacity.

Since the address range is single, the BootRAM, the bufferRAM and the register set are multiplexed.

BootRAM: The bootRAM of chip1 is selected always, and the contents of the block 0 of chip1 are copied to it at startup.

DataRAM: DBS setting in Start Address2 Register(See Section 2.8.10) decides which DataRAM is selected.

Register Set: In the case of write, both registers in chip1 and chip2 will be written(Regardless of DBS). Reading out from register of chip1/ chip2 follows the DBS setting(See Section 2.8.10).

QDP(Quad Die Package):

A QDP is made up of 2 DDP chips and is effectively 2 separate Flex-OneNAND devices in the same die.

There are 2 chip select pins (CE1 and CE2) on a QDP device, using which one of the two devices can be selected.

Since there are separate chip-selects for the two devices, they have different address ranges and register sets which can be directly accessed by the processor.

Thus each of the registers/BufferRAMs can be selected by using the CE pin, and then using the same settings that apply to a DDP chip.

8.0 PACKAGE DIMENSIONS (TBD)

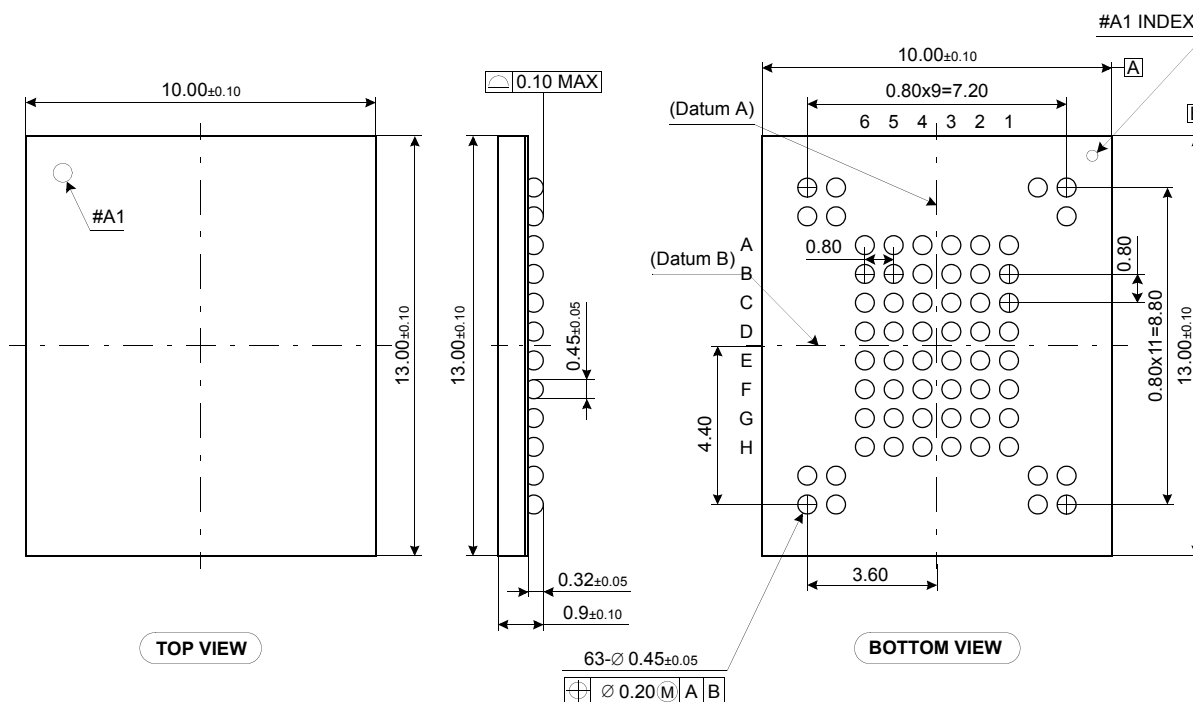

4G product (KFG4GH6x4M)

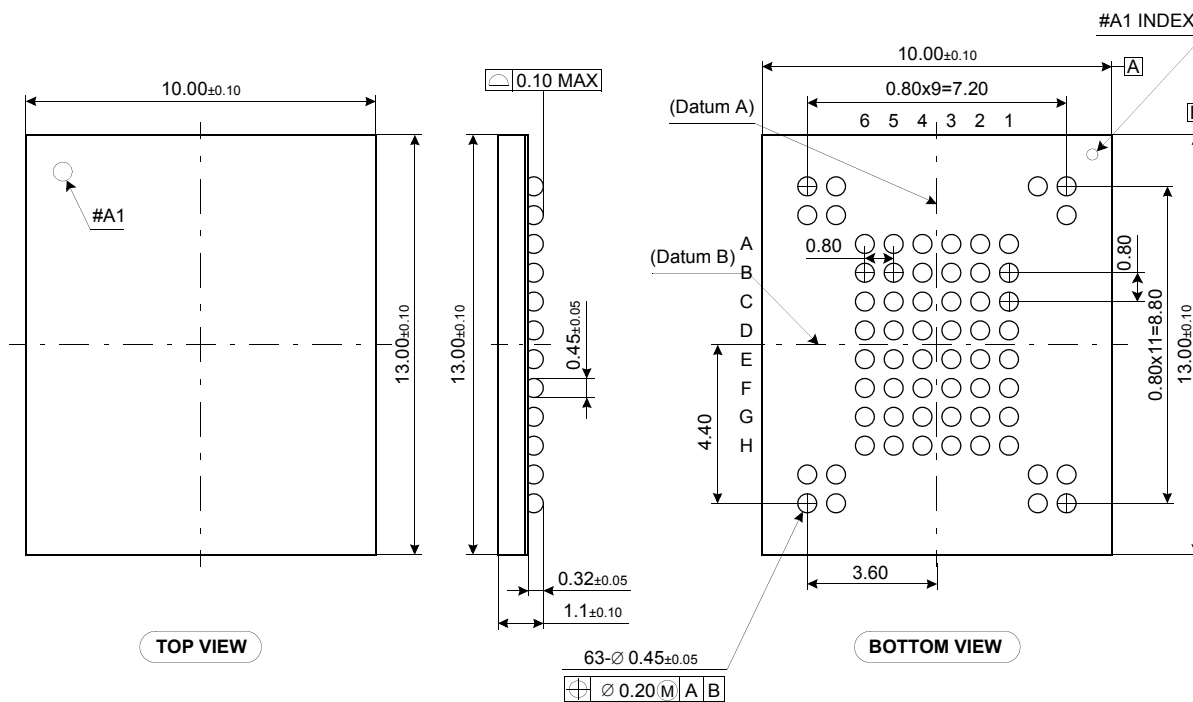

8G product (KFH8GH6x4M)

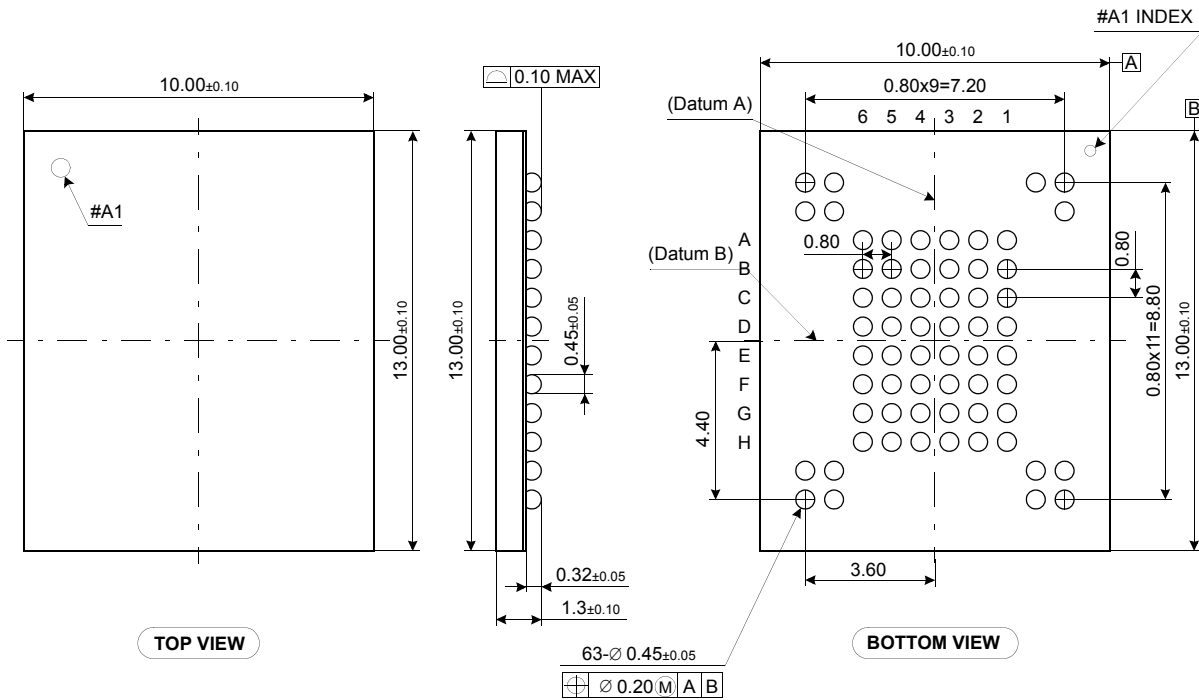

16G product (KFWAGH6x4M)

63- \varnothing 0.45 \pm 0.05
 \oplus \varnothing 0.20 M | A | B