

ProASIC[®]3 nano Flash FPGAs



Features and Benefits

Wide Range of Features

- 10 k to 250 k System Gates
- Up to 36 kbits of True Dual-Port SRAM
- Up to 71 User I/Os

Reprogrammable Flash Technology

- 130-nm, 7-Layer Metal (6 Copper), Flash-Based CMOS Process
- Live at Power-Up (LAPU) Level 0 Support
- Single-Chip Solution
- Retains Programmed Design when Powered Off

High Performance

- 350 MHz System Performance

In-System Programming (ISP) and Security

- Secure ISP Using On-Chip 128-Bit Advanced Encryption Standard (AES) Decryption via JTAG (IEEE 1532-compliant)[†]
- FlashLock[®] to Secure FPGA Contents

Low Power

- Low-Power ProASIC3 nano Products
- 1.5 V Core Voltage for Low Power
- Support for 1.5 V-Only Systems
- Low-Impedance Flash Switches

High-Performance Routing Hierarchy

- Segmented, Hierarchical Routing and Clock Structure

Advanced I/Os

- 1.5 V, 1.8 V, 2.5 V, and 3.3 V Mixed-Voltage Operation
- Bank-Selectable I/O Voltages—up to 4 Banks per Chip
- Single-Ended I/O Standards: LVTTTL, LVCMOS 3.3 V / 2.5 V / 1.8 V / 1.5 V
- Wide Range Power Supply Voltage Support per JESD8-B, Allowing I/Os to Operate from 2.7 V to 3.6 V
- I/O Registers on Input, Output, and Enable Paths
- Selectable Schmitt Trigger Inputs
- Hot-Swappable and Cold-Sparing I/Os
- Programmable Output Slew Rate[†] and Drive Strength
- Weak Pull-Up/-Down
- IEEE 1149.1 (JTAG) Boundary Scan Test
- Pin-Compatible Packages across the ProASIC3 Family

Clock Conditioning Circuit (CCC) and PLL[†]

- Up to Six CCC Blocks, One with an Integrated PLL
- Configurable Phase Shift, Multiply/Divide, Delay Capabilities and External Feedback
- Wide Input Frequency Range (1.5 MHz to 350 MHz)

Embedded Memory

- 1 kbit of FlashROM User Nonvolatile Memory
- SRAMs and FIFOs with Variable-Aspect-Ratio 4,608-Bit RAM Blocks (x1, x2, x4, x9, and x18 organizations)[†]
- True Dual-Port SRAM (except x18 organization)[†]

Enhanced Commercial Temperature Range

- -20°C to +70°C

Table 1 • ProASIC3 nano Devices

ProASIC3 nano Devices	A3PN010	A3PN015	A3PN020	A3PN030 ¹	A3PN060	A3PN125	A3PN250
System Gates	10 k	15 k	20 k	30 k	60 k	125 k	250 k
Typical Equivalent Macrocells	86	128	172	256	512	1,024	2,048
VersaTiles (D-flip-flops)	260	384	520	768	1,536	3,072	6,144
RAM kbits (1,024 bits) ²	–	–	–	–	18	36	36
4,608-Bit Blocks ²	–	–	–	–	4	8	8
FlashROM Bits	1 k	1 k	1 k	1 k	1 k	1 k	1 k
Secure (AES) ISP ²	–	–	–	–	Yes	Yes	Yes
Integrated PLL in CCCs ²	–	–	–	–	1	1	1
VersaNet Globals	4	4	4	6	18	18	18
I/O Banks	2	3	3	2	2	2	4
Maximum User I/Os (packaged device)	34	49	49	77	71	71	68
Maximum User I/Os (Known Good Die)	34	–	52	83	71	71	68
Package Pins							
QFN	QN48	QN68	QN68	QN48, QN68	VQ100	VQ100	VQ100
VQFP				VQ100			

Notes:

1. A3PN030 is available in the Z feature grade only.
2. A3PN030 and smaller devices do not support this feature.
3. For higher densities and support of additional features, refer to the ProASIC3 and ProASIC3E handbooks.

[†] A3PN030 and smaller devices do not support this feature.

I/Os Per Package

ProASIC3 nano Devices	A3PN010	A3PN015	A3PN020	A3PN030 ¹	A3PN060	A3PN125	A3PN250
Known Good Die	34	–	52	83	71	71	68
QN48	34			34			
QN68		49	49	49			
VQ100				77	71	71	68

Notes:

1. A3PN030 is available in the Z feature grade only and offers package compatibility with the lower density nano devices. Refer to "ProASIC3 nano Ordering Information" on page III.
2. When considering migrating your design to a lower- or higher-density device, refer to the ProASIC3 Handbook to ensure compliance with design and board migration requirements.
3. "G" indicates RoHS-compliant packages. Refer to "ProASIC3 nano Ordering Information" on page III for the location of the "G" in the part number. For nano devices, the VQ100 package is offered in both leaded and RoHS-compliant versions. All other packages are RoHS-compliant only.

Table 2 • ProASIC3 nano FPGAs Package Sizes Dimensions

Packages	QN48	QN68	VQ100
Length × Width (mm \ mm)	6 x 6	8 x 8	14 x 14
Nominal Area (mm ²)	36	64	196
Pitch (mm)	0.4	0.4	0.5
Height (mm)	0.90	0.90	1.20

ProASIC3 nano Ordering Information

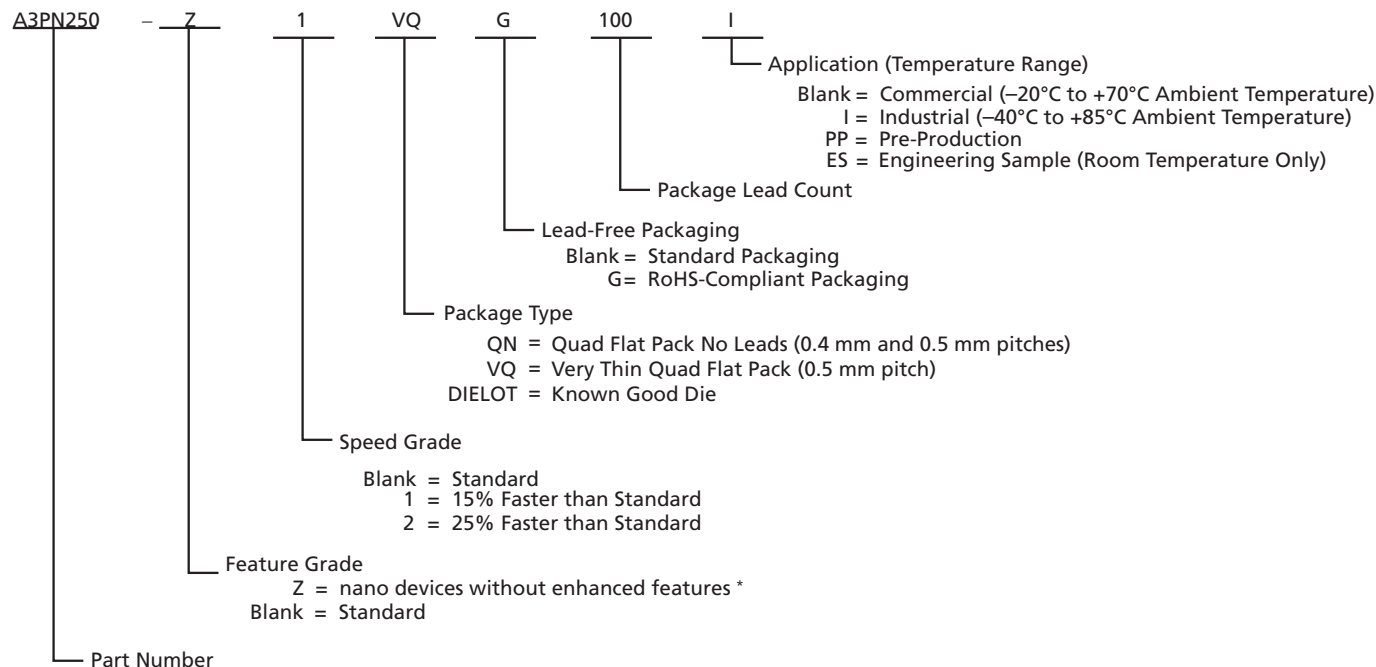

Note: *For the A3PN060, A3PN125, and A3PN250, the Z feature grade does not support the enhanced nano features of Schmitt trigger input, cold-sparing, and hot-swap I/O capability. The A3PN030 Z feature grade does not support Schmitt trigger input. For the VQ100, CS81, UC81, QN68, and QN48 packages, the Z feature grade and the N part number are not marked on the device.

Device Marking

Actel normally topside marks the full ordering part number on each device. There are some exceptions to this, such as some of the Z feature grade nano devices, the V2 designator for IGLOO devices, and packages where space is physically limited. Packages that have limited characters available are UC36, UC81, CS81, QN48, QN68, and QFN132. On these specific packages, a subset of the device marking will be used that includes the required legal information and as much of the part number as allowed by character limitation of the device. In this case, devices will have a truncated device marking and may exclude the applications markings, such as the I designator for Industrial Devices or the ES designator for Engineering Samples.

Figure 1 shows an example of device marking based on the AGL030V5-UCG81. The actual mark will vary by the device/package combination ordered.

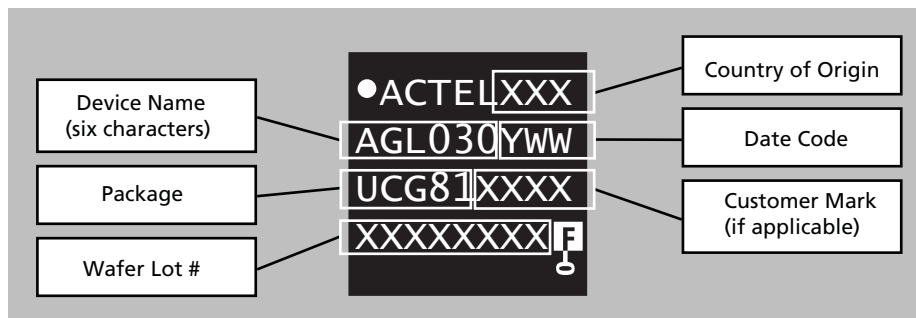

Figure 1 • Example of Device Marking for Small Form Factor Packages

ProASIC3 nano Product Available in the Z Feature Grade

Devices	A3PN030	A3PN060	A3PN125	A3PN250
Packages	QN48	-	-	-
	QN68	-	-	-
	VQ100	VQ100	VQ100	VQ100

Temperature Grade Offerings

ProASIC3 nano Devices	A3PN010	A3PN015	A3PN020	A3PN030	A3PN060	A3PN125	A3PN250
QN48	C, I	-	-	C, I	-	-	-
QN68	-	C, I	C, I	C, I	-	-	-
VQ100	-	-	-	C, I	C, I	C, I	C, I

Notes:

1. C = Commercial temperature range: -20°C to 70°C ambient temperature
2. I = Industrial temperature range: -40°C to 85°C ambient temperature

Speed Grade and Temperature Grade Matrix

Temperature Grade	Std.
C ¹	✓
I ²	✓

Notes:

1. C = Commercial temperature range: -20°C to 70°C ambient temperature.
2. I = Industrial temperature range: -40°C to 85°C ambient temperature.

Contact your local Actel representative for device availability: <http://www.actel.com/contact/default.aspx>.

1 – ProASIC3 nano Device Overview

General Description

ProASIC3, the third-generation family of Actel flash FPGAs, offers performance, density, and features beyond those of the ProASIC^{PLUS}® family. Nonvolatile flash technology gives ProASIC3 nano devices the advantage of being a secure, low-power, single-chip solution that is live at power-up (LAPU). ProASIC3 nano devices are reprogrammable and offer time-to-market benefits at an ASIC-level unit cost. These features enable designers to create high-density systems using existing ASIC or FPGA design flows and tools.

ProASIC3 nano devices offer 1 kbit of on-chip, reprogrammable, nonvolatile FlashROM storage as well as clock conditioning circuitry based on an integrated phase-locked loop (PLL). A3PN030 and smaller devices do not have PLL or RAM support. ProASIC3 nano devices have up to 250,000 system gates, supported with up to 36 kbits of true dual-port SRAM and up to 71 user I/Os.

ProASIC3 nano devices increase the breadth of the ProASIC3 product line by adding new features and packages for greater customer value in high volume consumer, portable, and battery-backed markets. Added features include smaller footprint packages designed with two-layer PCBs in mind, low power, hot-swap capability, and Schmitt trigger for greater flexibility in low-cost and power-sensitive applications.

Flash Advantages

Reduced Cost of Ownership

Advantages to the designer extend beyond low unit cost, performance, and ease of use. Unlike SRAM-based FPGAs, flash-based ProASIC3 nano devices allow all functionality to be live at power-up; no external boot PROM is required. On-board security mechanisms prevent access to all the programming information and enable secure remote updates of the FPGA logic. Designers can perform secure remote in-system reprogramming to support future design iterations and field upgrades with confidence that valuable intellectual property (IP) cannot be compromised or copied. Secure ISP can be performed using the industry-standard AES algorithm. The ProASIC3 nano device architecture mitigates the need for ASIC migration at higher user volumes. This makes the ProASIC3 nano device a cost-effective ASIC replacement solution, especially for applications in the consumer, networking/communications, computing, and avionics markets.

With a variety of devices under \$1, Actel ProASIC3 nano FPGAs enable cost-effective implementation of programmable logic and quick time to market.

Security

Nonvolatile, flash-based ProASIC3 nano devices do not require a boot PROM, so there is no vulnerable external bitstream that can be easily copied. ProASIC3 nano devices incorporate FlashLock, which provides a unique combination of reprogrammability and design security without external overhead, advantages that only an FPGA with nonvolatile flash programming can offer.

ProASIC3 nano devices utilize a 128-bit flash-based lock and a separate AES key to secure programmed intellectual property and configuration data. In addition, all FlashROM data in ProASIC3 nano devices can be encrypted prior to loading, using the industry-leading AES-128 (FIPS192) bit block cipher encryption standard. The AES standard was adopted by the National Institute of Standards and Technology (NIST) in 2000 and replaces the 1977 DES standard. ProASIC3 nano devices have a built-in AES decryption engine and a flash-based AES key that make them the most comprehensive programmable logic device security solution available today. ProASIC3 nano devices with AES-based security allow for secure, remote field updates over public networks such as the Internet, and ensure that valuable IP remains out of the hands of system overbuilders, system cloners, and IP thieves. The contents of a programmed ProASIC3 nano device cannot be read back, although secure design verification is possible.

Security, built into the FPGA fabric, is an inherent component of ProASIC3 nano devices. The flash cells are located beneath seven metal layers, and many device design and layout techniques have been used to make invasive attacks extremely difficult. ProASIC3 nano devices, with FlashLock and AES security, are unique in being highly resistant to both invasive and noninvasive attacks. Your valuable IP is protected and secure, making remote ISP possible. A ProASIC3 nano device provides the most impenetrable security for programmable logic designs.

Single Chip

Flash-based FPGAs store their configuration information in on-chip flash cells. Once programmed, the configuration data is an inherent part of the FPGA structure, and no external configuration data needs to be loaded at system power-up (unlike SRAM-based FPGAs). Therefore, flash-based ProASIC3 nano FPGAs do not require system configuration components such as EEPROMs or microcontrollers to load device configuration data. This reduces bill-of-materials costs and PCB area, and increases security and system reliability.

Live at Power-Up

Actel flash-based ProASIC3 nano devices support Level 0 of the LAPU classification standard. This feature helps in system component initialization, execution of critical tasks before the processor wakes up, setup and configuration of memory blocks, clock generation, and bus activity management. The LAPU feature of flash-based ProASIC3 nano devices greatly simplifies total system design and reduces total system cost, often eliminating the need for CPLDs and clock generation PLLs that are used for these purposes in a system. In addition, glitches and brownouts in system power will not corrupt the ProASIC3 nano device's flash configuration, and unlike SRAM-based FPGAs, the device will not have to be reloaded when system power is restored. This enables the reduction or complete removal of the configuration PROM, expensive voltage monitor, brownout detection, and clock generator devices from the PCB design. Flash-based ProASIC3 nano devices simplify total system design and reduce cost and design risk while increasing system reliability and improving system initialization time.

Firm Errors

Firm errors occur most commonly when high-energy neutrons, generated in the upper atmosphere, strike a configuration cell of an SRAM FPGA. The energy of the collision can change the state of the configuration cell and thus change the logic, routing, or I/O behavior in an unpredictable way. These errors are impossible to prevent in SRAM FPGAs. The consequence of this type of error can be a complete system failure. Firm errors do not exist in the configuration memory of ProASIC3 nano flash-based FPGAs. Once it is programmed, the flash cell configuration element of ProASIC3 nano FPGAs cannot be altered by high-energy neutrons and is therefore immune to them. Recoverable (or soft) errors occur in the user data SRAM of all FPGA devices. These can easily be mitigated by using error detection and correction (EDAC) circuitry built into the FPGA fabric.

Low Power

Flash-based ProASIC3 nano devices exhibit power characteristics similar to an ASIC, making them an ideal choice for power-sensitive applications. ProASIC3 nano devices have only a very limited power-on current surge and no high-current transition period, both of which occur on many FPGAs.

ProASIC3 nano devices also have low dynamic power consumption to further maximize power savings.

Advanced Flash Technology

ProASIC3 nano devices offer many benefits, including nonvolatility and reprogrammability through an advanced flash-based, 130-nm LVC MOS process with seven layers of metal. Standard CMOS design techniques are used to implement logic and control functions. The combination of fine granularity, enhanced flexible routing resources, and abundant flash switches allows for very high logic utilization without compromising device routability or performance. Logic functions within the device are interconnected through a four-level routing hierarchy.

Advanced Architecture

The proprietary ProASIC3 nano architecture provides granularity comparable to standard-cell ASICs. The ProASIC3 nano device consists of five distinct and programmable architectural features (Figure 1-3 to Figure 1-4 on page 1-5):

- FPGA VersaTiles
- Dedicated FlashROM
- Dedicated SRAM/FIFO memory
- Extensive CCCs and PLLs
- Advanced I/O structure

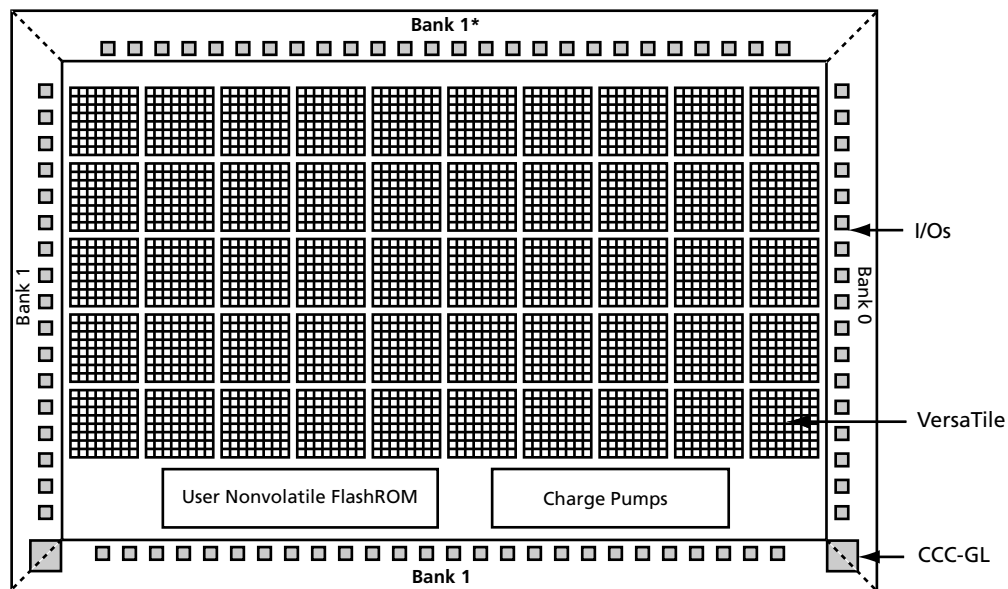

Note: *Bank 0 for the A3PN030 device

Figure 1-1 • ProASIC3 Device Architecture Overview with Two I/O Banks and No RAM (A3PN010 and A3PN030)

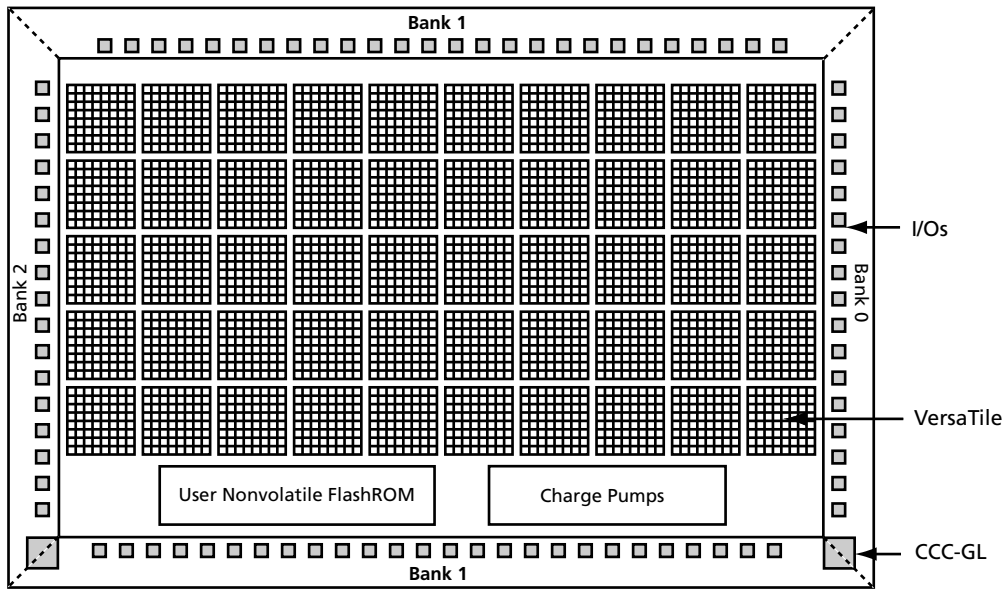

Figure 1-2 • ProASIC3 nano Architecture Overview with Three I/O Banks and No RAM (A3PN015 and A3PN020)

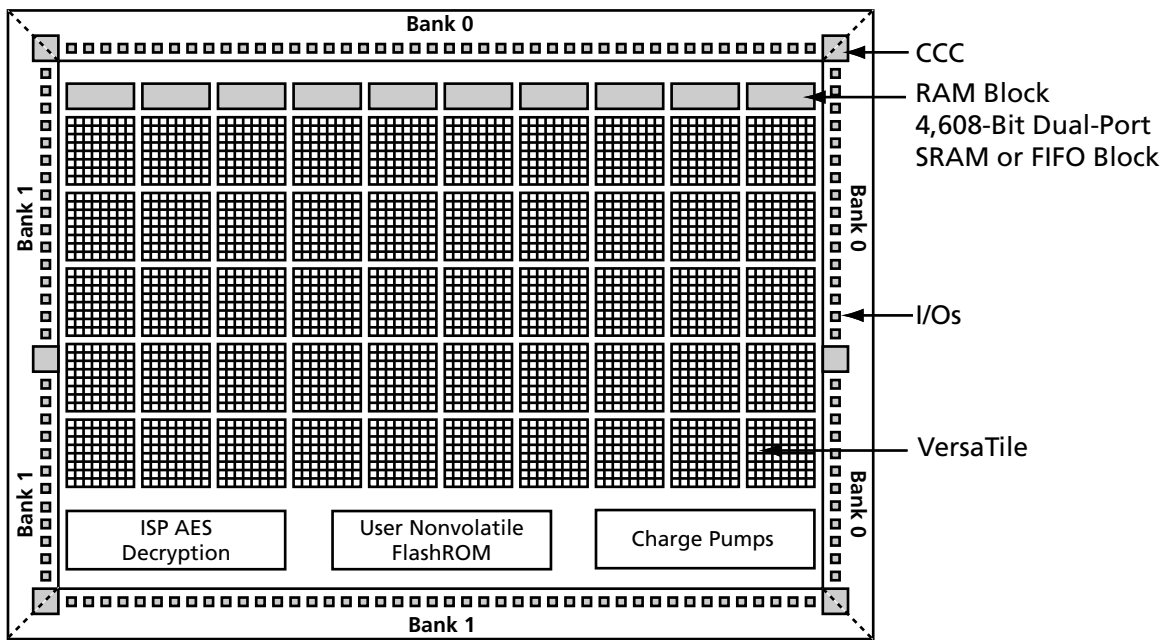

Figure 1-3 • ProASIC3 nano Device Architecture Overview with Two I/O Banks (A3PN060 and A3PN125)

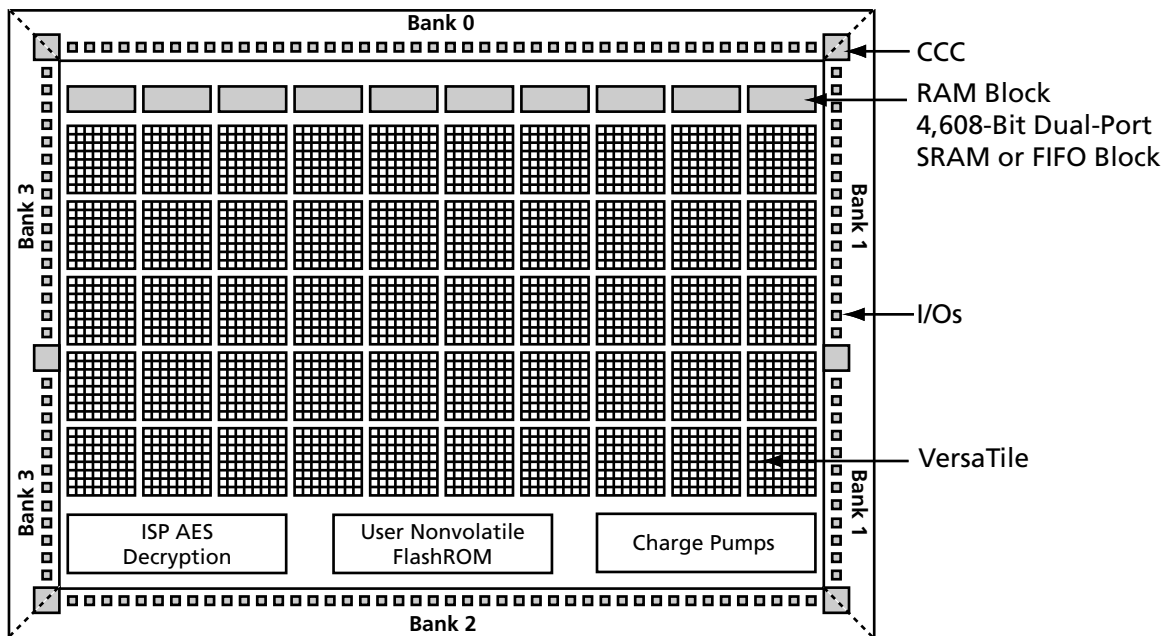

Figure 1-4 • ProASIC3 nano Device Architecture Overview with Four I/O Banks (A3PN250)

The FPGA core consists of a sea of VersaTiles. Each VersaTile can be configured as a three-input logic function, a D-flip-flop (with or without enable), or a latch by programming the appropriate flash switch interconnections. The versatility of the ProASIC3 nano core tile as either a three-input lookup table (LUT) equivalent or as a D-flip-flop/latch with enable allows for efficient use of the FPGA fabric. The VersaTile capability is unique to the Actel ProASIC3 family of third-generation architecture flash FPGAs. VersaTiles are connected with any of the four levels of routing hierarchy. Flash switches are distributed throughout the device to provide nonvolatile, reconfigurable interconnect programming. Maximum core utilization is possible for virtually any design.

In addition, extensive on-chip programming circuitry allows for rapid, single-voltage (3.3 V) programming of ProASIC3 nano devices via an IEEE 1532 JTAG interface.

VersaTiles

The ProASIC3 nano core consists of VersaTiles, which have been enhanced beyond the ProASIC^{PLUS}® core tiles. The ProASIC3 nano VersaTile supports the following:

- All 3-input logic functions—LUT-3 equivalent
- Latch with clear or set
- D-flip-flop with clear or set
- Enable D-flip-flop with clear or set

Refer to [Figure 1-5](#) for VersaTile configurations.

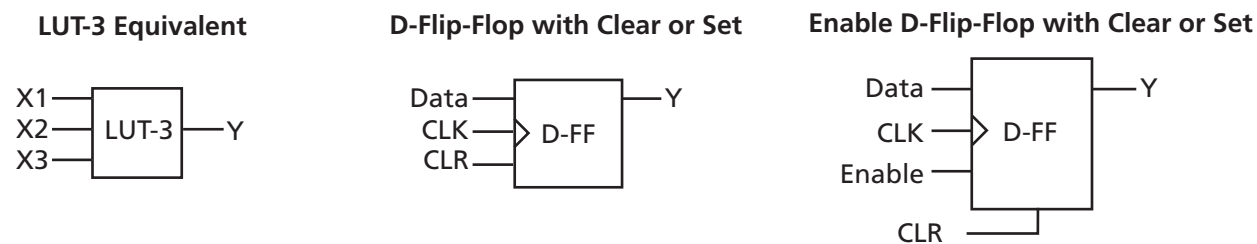

Figure 1-5 • VersaTile Configurations

User Nonvolatile FlashROM

Actel ProASIC3 nano devices have 1 kbit of on-chip, user-accessible, nonvolatile FlashROM. The FlashROM can be used in diverse system applications:

- Internet protocol addressing (wireless or fixed)
- System calibration settings
- Device serialization and/or inventory control
- Subscription-based business models (for example, set-top boxes)
- Secure key storage for secure communications algorithms
- Asset management/tracking
- Date stamping
- Version management

The FlashROM is written using the standard ProASIC3 nano IEEE 1532 JTAG programming interface. The core can be individually programmed (erased and written), and on-chip AES decryption can be used selectively to securely load data over public networks (except in the A3PN030 and smaller devices), as in security keys stored in the FlashROM for a user design.

The FlashROM can be programmed via the JTAG programming interface, and its contents can be read back either through the JTAG programming interface or via direct FPGA core addressing. Note that the FlashROM can only be programmed from the JTAG interface and cannot be programmed from the internal logic array.

The FlashROM is programmed as 8 banks of 128 bits; however, reading is performed on a byte-by-byte basis using a synchronous interface. A 7-bit address from the FPGA core defines which of the 8 banks and which of the 16 bytes within that bank are being read. The three most significant bits (MSBs) of the FlashROM address determine the bank, and the four least significant bits (LSBs) of the FlashROM address define the byte.

The Actel ProASIC3 nano development software solutions, Libero® Integrated Design Environment (IDE) and Designer, have extensive support for the FlashROM. One such feature is auto-generation of sequential programming files for applications requiring a unique serial number in each part. Another feature enables the inclusion of static data for system version control. Data for the FlashROM can be generated quickly and easily using Actel Libero IDE and Designer software tools. Comprehensive programming file support is also included to allow for easy programming of large numbers of parts with differing FlashROM contents.

SRAM and FIFO

ProASIC3 nano devices (except the A3PN030 and smaller devices) have embedded SRAM blocks along their north and south sides. Each variable-aspect-ratio SRAM block is 4,608 bits in size. Available memory configurations are 256×18, 512×9, 1k×4, 2k×2, and 4k×1 bits. The individual blocks have independent read and write ports that can be configured with different bit widths on each port. For example, data can be sent through a 4-bit port and read as a single bitstream. The embedded SRAM blocks can be initialized via the device JTAG port (ROM emulation mode) using the UJTAG macro (except in A3PN030 and smaller devices).

In addition, every SRAM block has an embedded FIFO control unit. The control unit allows the SRAM block to be configured as a synchronous FIFO without using additional core VersaTiles. The FIFO width and depth are programmable. The FIFO also features programmable Almost Empty (AEMPTY) and Almost Full (AFULL) flags in addition to the normal Empty and Full flags. The embedded FIFO control unit contains the counters necessary for generation of the read and write address pointers. The embedded SRAM/FIFO blocks can be cascaded to create larger configurations.

PLL and CCC

Higher density ProASIC3 nano devices using either the two I/O bank or four I/O bank architectures provide the designer with very flexible clock conditioning capabilities. A3PN060, A3PN125, and A3PN250 contain six CCCs. One CCC (center west side) has a PLL. The A3PN030 and smaller devices use different CCCs in their architecture. These CCC-GLs contain a global MUX but do not have any PLLs or programmable delays.

For devices using the six CCC block architecture, these six CCC blocks are located at the four corners and the centers of the east and west sides.

All six CCC blocks are usable; the four corner CCCs and the east CCC allow simple clock delay operations as well as clock spine access. The inputs of the six CCC blocks are accessible from the FPGA core or from dedicated connections to the CCC block, which are located near the CCC.

The CCC block has these key features:

- Wide input frequency range (f_{IN_CCC}) = 1.5 MHz to 350 MHz
- Output frequency range (f_{OUT_CCC}) = 0.75 MHz to 350 MHz
- Clock delay adjustment via programmable and fixed delays from -7.56 ns to $+11.12$ ns
- 2 programmable delay types for clock skew minimization
- Clock frequency synthesis (for PLL only)

Additional CCC specifications:

- Internal phase shift = 0° , 90° , 180° , and 270° . Output phase shift depends on the output divider configuration (for PLL only).
- Output duty cycle = $50\% \pm 1.5\%$ or better (for PLL only)
- Low output jitter: worst case $< 2.5\% \times$ clock period peak-to-peak period jitter when single global network used (for PLL only)
- Maximum acquisition time = $300 \mu\text{s}$ (for PLL only)
- Low power consumption of 5 mW
- Exceptional tolerance to input period jitter—allowable input jitter is up to 1.5 ns (for PLL only)
- Four precise phases; maximum misalignment between adjacent phases of $40 \text{ ps} \times (350 \text{ MHz} / f_{OUT_CCC})$ (for PLL only)

Global Clocking

ProASIC3 nano devices have extensive support for multiple clocking domains. In addition to the CCC and PLL support described above, there is a comprehensive global clock distribution network.

Each VersaTile input and output port has access to nine VersaNets: six chip (main) and three quadrant global networks. The VersaNets can be driven by the CCC or directly accessed from the core via multiplexers (MUXes). The VersaNets can be used to distribute low-skew clock signals or for rapid distribution of high fanout nets.

I/Os with Advanced I/O Standards

ProASIC3 nano FPGAs feature a flexible I/O structure, supporting a range of voltages (1.5 V, 1.8 V, 2.5 V, and 3.3 V).

The I/Os are organized into banks, with two, three, or four banks per device. The configuration of these banks determines the I/O standards supported.

Each I/O module contains several input, output, and enable registers. These registers allow the implementation of various single-data-rate applications for all versions of nano devices and double-data-rate applications for the A3PN060, A3PN125, and A3PN250 devices.

ProASIC3 nano devices support LVTTTL and LVCMOS I/O standards, are hot-swappable, and support cold-sparing and Schmitt trigger.

Hot-swap (also called hot-plug, or hot-insertion) is the operation of hot-insertion or hot-removal of a card in a powered-up system.

Cold-sparing (also called cold-swap) refers to the ability of a device to leave system data undisturbed when the system is powered up, while the component itself is powered down, or when power supplies are floating.

Wide Range I/O Support

Actel nano devices support JEDEC-defined wide range I/O operation. ProASIC3 nano supports the JESD8-B specification, covering both 3 V and 3.3 V supplies, for an effective operating range of 2.7 V to 3.6 V.

Wider I/O range means designers can eliminate power supplies or power conditioning components from the board or move to less costly components with greater tolerances. Wide range eases I/O bank management and provides enhanced protection from system voltage spikes, while providing the flexibility to easily run custom voltage applications.

Part Number and Revision Date

Part Number 51700111-001-5

Revised January 2010

List of Changes

The following table lists critical changes that were made in the current version of the document.

Previous Version	Changes in Current Version (Advance v0.6)	Page
Advance v0.5 (August 2009)	The note for A3PN030 in the "ProASIC3 nano Devices" table was revised. It states A3PN030 is available in the Z feature grade only.	I
Advance v0.4 (January 2009)	All references to speed grade –F were removed from this document.	N/A
	The "I/Os with Advanced I/O Standards" section was revised to add definitions of hot-swap and cold-sparing.	1-7
Advance v0.3 (November 2008)	Table 1 · ProASIC3 nano Devices was revised to change the maximum user I/Os for A3PN020 and A3PN030. The following table note was removed: "Six chip (main) and three quadrant global networks are available for A3PN060 and above."	I
	The QN100 package was removed for all devices.	N/A
	The "Device Marking" section is new.	III
Advance v0.2 (October 2008)	The A3PN030 device was added to product tables and replaces A3P030 entries that were formerly in the tables.	I to IV
	The "Wide Range I/O Support" section is new.	1-8
Advance v0.1 (October 2008)	The "I/Os Per Package" table was updated to add the following information to table note 4: "For nano devices, the VQ100 package is offered in both leaded and RoHS-compliant versions. All other packages are RoHS-compliant only."	II
	The "ProASIC3 nano Product Available in the Z Feature Grade" section was updated to remove QN100 for A3PN250.	IV
	The "General Description" section was updated to give correct information about number of gates and dual-port RAM for ProASIC3 nano devices.	1-1
	The device architecture figures, Figure 1-3 · ProASIC3 nano Device Architecture Overview with Two I/O Banks (A3PN060 and A3PN125) through Figure 1-4 · ProASIC3 nano Device Architecture Overview with Four I/O Banks (A3PN250), were revised. Figure 1-1 · ProASIC3 Device Architecture Overview with Two I/O Banks and No RAM (A3PN010 and A3PN030) is new.	1-3 through 1-5
	The "PLL and CCC" section was revised to include information about CCC-GLs in A3PN020 and smaller devices.	1-6

Datasheet Categories

Categories

In order to provide the latest information to designers, some datasheets are published before data has been fully characterized. Datasheets are designated as "Product Brief," "Advance," "Preliminary," and "Production." The definitions of these categories are as follows:

Product Brief

The product brief is a summarized version of a datasheet (advance or production) and contains general product information. This document gives an overview of specific device and family information.

Advance

This version contains initial estimated information based on simulation, other products, devices, or speed grades. This information can be used as estimates, but not for production. This label only applies to the DC and Switching Characteristics chapter of the datasheet and will only be used when the data has not been fully characterized.

Preliminary

The datasheet contains information based on simulation and/or initial characterization. The information is believed to be correct, but changes are possible.

Unmarked (production)

This version contains information that is considered to be final.

Export Administration Regulations (EAR)

The products described in this document are subject to the Export Administration Regulations (EAR). They could require an approved export license prior to export from the United States. An export includes release of product or disclosure of technology to a foreign national inside or outside the United States.

Actel Safety Critical, Life Support, and High-Reliability Applications Policy

The Actel products described in this advance status document may not have completed Actel's qualification process. Actel may amend or enhance products during the product introduction and qualification process, resulting in changes in device functionality or performance. It is the responsibility of each customer to ensure the fitness of any Actel product (but especially a new product) for a particular purpose, including appropriateness for safety-critical, life-support, and other high-reliability applications. Consult Actel's Terms and Conditions for specific liability exclusions relating to life-support applications. A reliability report covering all of Actel's products is available on the Actel website at http://www.actel.com/documents/ORT_Report.pdf. Actel also offers a variety of enhanced qualification and lot acceptance screening procedures. Contact your local Actel sales office for additional reliability information.

2 – ProASIC3 nano DC and Switching Characteristics

General Specifications

The Z feature grade does not support the enhanced nano features of Schmitt trigger input, cold-sparing, and hot-swap I/O capability. Refer to the ordering information in the *ProASIC3 nano Product Brief* for more information.

DC and switching characteristics for –F speed grade targets are based only on simulation.

The characteristics provided for the –F speed grade are subject to change after establishing FPGA specifications. Some restrictions might be added and will be reflected in future revisions of this document. The –F speed grade is only supported in the commercial temperature range.

Operating Conditions

Stresses beyond those listed in [Table 2-1](#) may cause permanent damage to the device.

Exposure to absolute maximum rating conditions for extended periods may affect device reliability. Absolute Maximum Ratings are stress ratings only; functional operation of the device at these or any other conditions beyond those listed under the Recommended Operating Conditions specified in [Table 2-2 on page 2-2](#) is not implied.

Table 2-1 • Absolute Maximum Ratings

Symbol	Parameter	Limits	Units
V _{CC}	DC core supply voltage	–0.3 to 1.65	V
V _{JTAG}	JTAG DC voltage	–0.3 to 3.75	V
V _{PUMP}	Programming voltage	–0.3 to 3.75	V
V _{CCPLL}	Analog power supply (PLL)	–0.3 to 1.65	V
V _{CCI}	DC I/O output buffer supply voltage	–0.3 to 3.75	V
V _I	I/O input voltage	–0.3 V to 3.6 V	V
T _{STG} ¹	Storage temperature	–65 to +150	°C
T _J ¹	Junction temperature	+125	°C

Notes:

1. For flash programming and retention maximum limits, refer to [Table 2-3 on page 2-2](#), and for recommended operating limits, refer to [Table 2-2 on page 2-2](#).
2. The device should be operated within the limits specified by the datasheet. During transitions, the input signal may undershoot or overshoot according to the limits shown in [Table 2-4 on page 2-3](#).

Table 2-2 • Recommended Operating Conditions ^{1, 2}

Symbol	Parameter		Extended Commercial	Industrial	Units
T _A	Ambient temperature		-20 to +70 ²	-40 to +85 ²	°C
T _J	Junction temperature		-20 to +85	-40 to +100	°C
V _{CC} ³	1.5 V DC core supply voltage		1.425 to 1.575	1.425 to 1.575	V
V _{JTAG}	JTAG DC voltage		1.425 to 3.6	1.425 to 3.6	V
V _{PUMP} ⁴	Programming voltage	Programming Mode	0 to 3.45	0 to 3.45	V
		Operation ⁴	0 to 3.6	0 to 3.6	V
V _{CCPLL} ⁵	Analog power supply (PLL)	1.5 V DC core supply voltage ³	1.425 to 1.575	1.425 to 1.575	V
V _{CCI} and VMV ⁷	1.5 V DC supply voltage		1.425 to 1.575	1.425 to 1.575	V
	1.8 V DC supply voltage		1.7 to 1.9	1.7 to 1.9	V
	2.5 V DC supply voltage		2.3 to 2.7	2.3 to 2.7	V
	3.3 V DC supply voltage		3.0 to 3.6	3.0 to 3.6	V
	3.3 V Wide Range supply voltage ⁶		2.7 to 3.6	2.7 to 3.6	V

Notes:

1. All parameters representing voltages are measured with respect to GND unless otherwise specified.
2. To ensure targeted reliability standards are met across ambient and junction operating temperatures, Actel recommends that the user follow best design practices using Actel's timing and power simulation tools.
3. The ranges given here are for power supplies only. The recommended input voltage ranges specific to each I/O standard are given in [Table 2-14 on page 2-15](#). VMV and V_{CCI} should be at the same voltage within a given I/O bank.
4. V_{PUMP} can be left floating during operation (not programming mode).
5. V_{CCPLL} pins should be tied to V_{CC} pins. See [Pin Descriptions](#) for further information.
6. 3.3 V Wide Range is compliant to the JESD8-B specification and supports 3.0 V V_{CCI} operation.
7. VMV pins must be connected to the corresponding V_{CCI} pins. See [Pin Descriptions](#) for further information.

Table 2-3 • Flash Programming Limits – Retention, Storage and Operating Temperature ¹

Product Grade	Programming Cycles	Program Retention (biased/unbiased)	Maximum Storage Temperature T _{STG} (°C) ²	Maximum Operating Junction Temperature T _J (°C) ²
Commercial	500	20 years	110	100
Industrial	500	20 years	110	100

Notes:

1. This is a stress rating only; functional operation at any condition other than those indicated is not implied.
2. These limits apply for program/data retention only. Refer to [Table 2-1 on page 2-1](#) and [Table 2-2](#) for device operating conditions and absolute limits.

Table 2-4 • Overshoot and Undershoot Limits ¹

V_{CCI} and VMV	Average V_{CCI} -GND Overshoot or Undershoot Duration as a Percentage of Clock Cycle ²	Maximum Overshoot/Undershoot ²
2.7 V or less	10%	1.4 V
	5%	1.49 V
3 V	10%	1.1 V
	5%	1.19 V
3.3 V	10%	0.79 V
	5%	0.88 V
3.6 V	10%	0.45 V
	5%	0.54 V

Notes:

1. Based on reliability requirements at 85°C.
2. The duration is allowed at one out of six clock cycles. If the overshoot/undershoot occurs at one out of two cycles, the maximum overshoot/undershoot has to be reduced by 0.15 V.

I/O Power-Up and Supply Voltage Thresholds for Power-On Reset (Commercial and Industrial)

Sophisticated power-up management circuitry is designed into every ProASIC[®]3 device. These circuits ensure easy transition from the powered-off state to the powered-up state of the device. The many different supplies can power up in any sequence with minimized current spikes or surges. In addition, the I/O will be in a known state through the power-up sequence. The basic principle is shown in [Figure 2-1 on page 2-4](#).

There are five regions to consider during power-up.

ProASIC3 I/Os are activated only if ALL of the following three conditions are met:

1. V_{CC} and V_{CCI} are above the minimum specified trip points ([Figure 2-1 on page 2-4](#)).
2. $V_{CCI} > V_{CC} - 0.75$ V (typical)
3. Chip is in the operating mode.

 V_{CCI} Trip Point:

Ramping up: 0.6 V < trip_point_up < 1.2 V

Ramping down: 0.5 V < trip_point_down < 1.1 V

 V_{CC} Trip Point:

Ramping up: 0.6 V < trip_point_up < 1.1 V

Ramping down: 0.5 V < trip_point_down < 1 V

V_{CC} and V_{CCI} ramp-up trip points are about 100 mV higher than ramp-down trip points. This specifically built-in hysteresis prevents undesirable power-up oscillations and current surges. Note the following:

- During programming, I/Os become tristated and weakly pulled up to V_{CCI} .
- JTAG supply, PLL power supplies, and charge pump V_{PUMP} supply have no influence on I/O behavior.

PLL Behavior at Brownout Condition

Actel recommends using monotonic power supplies or voltage regulators to ensure proper power-up behavior. Power ramp-up should be monotonic at least until V_{CC} and V_{CCPLLX} exceed brownout activation levels. The V_{CC} activation level is specified as 1.1 V worst-case (see [Figure 2-1 on page 2-4](#) for more details).

When PLL power supply voltage and/or V_{CC} levels drop below the V_{CC} brownout levels (0.75 V \pm 0.25 V), the PLL output lock signal goes low and/or the output clock is lost. Refer to the [Power-Up/Down Behavior of Low-Power Flash Devices](#) chapter of the handbook for information on clock and lock recovery.

Internal Power-Up Activation Sequence

1. Core
2. Input buffers
3. Output buffers, after 200 ns delay from input buffer activation

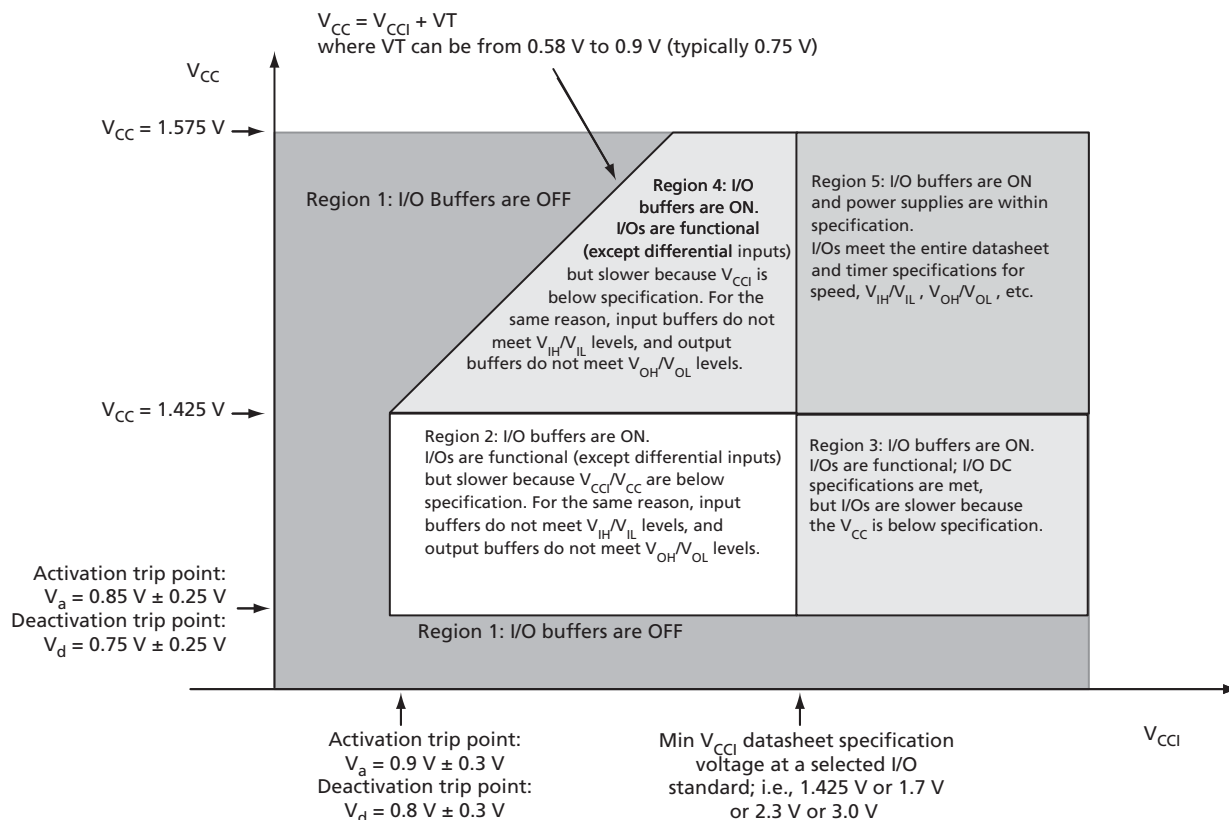

Figure 2-1 • I/O State as a Function of V_{CCI} and V_{CC} Voltage Levels

Thermal Characteristics

Introduction

The temperature variable in the Actel Designer software refers to the junction temperature, not the ambient temperature. This is an important distinction because dynamic and static power consumption cause the chip junction to be higher than the ambient temperature.

EQ 2-1 can be used to calculate junction temperature.

$$T_J = \text{Junction Temperature} = \Delta T + T_A$$

EQ 2-1

where:

T_A = Ambient Temperature

ΔT = Temperature gradient between junction (silicon) and ambient $\Delta T = \theta_{ja} * P$

θ_{ja} = Junction-to-ambient of the package. θ_{ja} numbers are located in Table 2-5.

P = Power dissipation

Package Thermal Characteristics

The device junction-to-case thermal resistivity is θ_{jc} and the junction-to-ambient air thermal resistivity is θ_{ja} . The thermal characteristics for θ_{ja} are shown for two air flow rates. The absolute maximum junction temperature is 100°C. EQ 2-2 shows a sample calculation of the absolute maximum power dissipation allowed for a 484-pin FBGA package at commercial temperature and in still air.

$$\text{Maximum Power Allowed} = \frac{\text{Max. junction temp. (}^\circ\text{C)} - \text{Max. ambient temp. (}^\circ\text{C)}}{\theta_{ja}(\text{}^\circ\text{C/W)}} = \frac{100^\circ\text{C} - 70^\circ\text{C}}{20.5^\circ\text{C/W}} = 1.463 \text{ W}$$

EQ 2-2

Table 2-5 • Package Thermal Resistivities

Package Type	Device	Pin Count	θ_{jc}	θ_{ja}			Units
				Still Air	200 ft./min.	500 ft./min.	
Quad Flat No Lead (QFN)	All devices	48	TBD	TBD	TBD	TBD	C/W
		68	TBD	TBD	TBD	TBD	C/W
		100	TBD	TBD	TBD	TBD	C/W
Very Thin Quad Flat Pack (VQFP)	All devices	100	10.0	35.3	29.4	27.1	C/W

Temperature and Voltage Derating Factors

Table 2-6 • Temperature and Voltage Derating Factors for Timing Delays (normalized to $T_J = 70^\circ\text{C}$, $V_{CC} = 1.425 \text{ V}$)

Array Voltage V_{CC} (V)	Junction Temperature ($^\circ\text{C}$)						
	-40°C	-20°C	0°C	25°C	70°C	85°C	110°C
1.425	0.968	0.973	0.979	0.991	1.000	1.006	1.013
1.500	0.888	0.894	0.899	0.910	0.919	0.924	0.930
1.575	0.836	0.841	0.845	0.856	0.864	0.870	0.875

Calculating Power Dissipation

Quiescent Supply Current

Table 2-7 • Quiescent Supply Current Characteristics

	A3PN010	A3PN015	A3PN020	A3PN060	A3PN125	A3PN250
Typical (25°C)	1 mA	1 mA	1 mA	2 mA	2 mA	3 mA
Max. (Commercial)	5 mA	5 mA	5 mA	10 mA	10 mA	20 mA
Max. (Industrial)	8 mA	8 mA	8 mA	15 mA	15 mA	30 mA

Notes:

1. I_{DD} Includes V_{CC} , V_{PUMP} , and V_{CCI} currents. Values do not include I/O static contribution, which is shown in Table 2-9.
2. -F speed grade devices may experience higher standby I_{DD} of up to five times the standard I_{DD} and higher I/O leakage.

Power per I/O Pin

Table 2-8 • Summary of I/O Input Buffer Power (Per Pin) – Default I/O Software Settings

	V_{CCI} (V)	Dynamic Power P_{AC9} (μ W/MHz)*
Single-Ended		
3.3 V LVTTTL / 3.3 V LVCMOS	3.3	16.26
3.3 V LVTTTL / 3.3 V LVCMOS – Schmitt Trigger	3.3	18.95
2.5 V LVCMOS	2.5	4.59
2.5 V LVCMOS – Schmitt Trigger	2.5	6.01
1.8 V LVCMOS	1.8	1.61
1.8 V LVCMOS – Schmitt Trigger	1.8	1.70
1.5 V LVCMOS (JESD8-11)	1.5	0.96
1.5 V LVCMOS (JESD8-11) – Schmitt Trigger	1.5	0.90

Note: * P_{AC9} is the total dynamic power measured on V_{CCI} .

Table 2-9 • Summary of I/O Output Buffer Power (per pin) – Default I/O Software Settings¹

	C_{LOAD} (pF) ²	V_{CCI} (V)	Dynamic Power P_{AC10} (μ W/MHz) ³
Single-Ended			
3.3 V LVTTTL / 3.3 V LVCMOS	10	3.3	162.43
2.5 V LVCMOS	10	2.5	92.49
1.8 V LVCMOS	10	1.8	47.48
1.5 V LVCMOS (JESD8-11)	10	1.5	32.75

Notes:

1. Dynamic power consumption is given for standard load and software default drive strength and output slew.
2. Values are for A3PN020, A3PN015, and A3PN010. A3PN060, A3PN125, and A3PN250 have a default loading of 35 pF.
3. P_{AC10} is the total dynamic power measured on V_{CCI} .

Power Consumption of Various Internal Resources

Table 2-10 • Different Components Contributing to Dynamic Power Consumption in ProASIC3 nano Devices

Parameter	Definition	Device Specific Dynamic Contributions (μW/MHz)					
		A3PN250	A3PN125	A3PN060	A3PN020	A3PN015	A3PN010
P _{AC1}	Clock contribution of a Global Rib	11.03	11.03	9.3	TBD	TBD	TBD
P _{AC2}	Clock contribution of a Global Spine	1.58	0.81	0.81	TBD	TBD	TBD
P _{AC3}	Clock contribution of a VersaTile row	0.81					
P _{AC4}	Clock contribution of a VersaTile used as a sequential module	0.12					
P _{AC5}	First contribution of a VersaTile used as a sequential module	0.07					
P _{AC6}	Second contribution of a VersaTile used as a sequential module	0.29					
P _{AC7}	Contribution of a VersaTile used as a combinatorial Module	0.29					
P _{AC8}	Average contribution of a routing net	0.70					
P _{AC9}	Contribution of an I/O input pin (standard-dependent)	See Table 2-8 on page 2-6.					
P _{AC10}	Contribution of an I/O output pin (standard-dependent)	See Table 2-9 on page 2-6.					
P _{AC11}	Average contribution of a RAM block during a read operation	25.00			N/A		
P _{AC12}	Average contribution of a RAM block during a write operation	30.00			N/A		
P _{AC13}	Dynamic contribution for PLL	2.60			N/A		

Note: *For a different output load, drive strength, or slew rate, Actel recommends using the Actel Power spreadsheet calculator or SmartPower tool in Libero® Integrated Design Environment (IDE) software.

Table 2-11 • Different Components Contributing to the Static Power Consumption in ProASIC3 nano Devices

Parameter	Definition	Device Specific Static Power (mW)					
		A3PN250	A3PN125	A3PN060	A3PN020	A3PN015	A3PN010
P _{DC1}	Array static power in Active mode	See Table 2-7 on page 2-6.					
P _{DC4}	Static PLL contribution ¹	2.55			N/A		
P _{DC5}	Bank quiescent power (V _{CCI} -dependent)	See Table 2-7 on page 2-6.					

Notes:

1. Minimum contribution of the PLL when running at lowest frequency.
2. For a different output load, drive strength, or slew rate, Actel recommends using the Actel Power spreadsheet calculator or SmartPower tool in Libero IDE.

Power Calculation Methodology

This section describes a simplified method to estimate power consumption of an application. For more accurate and detailed power estimations, use the SmartPower tool in Actel Libero IDE software.

The power calculation methodology described below uses the following variables:

- The number of PLLs as well as the number and the frequency of each output clock generated
- The number of combinatorial and sequential cells used in the design
- The internal clock frequencies
- The number and the standard of I/O pins used in the design
- The number of RAM blocks used in the design
- Toggle rates of I/O pins as well as VersaTiles—guidelines are provided in [Table 2-12 on page 2-10](#).
- Enable rates of output buffers—guidelines are provided for typical applications in [Table 2-13 on page 2-10](#).
- Read rate and write rate to the memory—guidelines are provided for typical applications in [Table 2-13 on page 2-10](#). The calculation should be repeated for each clock domain defined in the design.

Methodology

Total Power Consumption— P_{TOTAL}

$$P_{TOTAL} = P_{STAT} + P_{DYN}$$

P_{STAT} is the total static power consumption.

P_{DYN} is the total dynamic power consumption.

Total Static Power Consumption— P_{STAT}

$$P_{STAT} = P_{DC1} + N_{INPUTS} * P_{DC2} + N_{OUTPUTS} * P_{DC3}$$

N_{INPUTS} is the number of I/O input buffers used in the design.

$N_{OUTPUTS}$ is the number of I/O output buffers used in the design.

Total Dynamic Power Consumption— P_{DYN}

$$P_{DYN} = P_{CLOCK} + P_{S-CELL} + P_{C-CELL} + P_{NET} + P_{INPUTS} + P_{OUTPUTS} + P_{MEMORY} + P_{PLL}$$

Global Clock Contribution— P_{CLOCK}

$$P_{CLOCK} = (P_{AC1} + N_{SPINE} * P_{AC2} + N_{ROW} * P_{AC3} + N_{S-CELL} * P_{AC4}) * F_{CLK}$$

N_{SPINE} is the number of global spines used in the user design—guidelines are provided in [Table 2-12 on page 2-10](#).

N_{ROW} is the number of VersaTile rows used in the design—guidelines are provided in [Table 2-12 on page 2-10](#).

F_{CLK} is the global clock signal frequency.

N_{S-CELL} is the number of VersaTiles used as sequential modules in the design.

P_{AC1} , P_{AC2} , P_{AC3} , and P_{AC4} are device-dependent.

Sequential Cells Contribution— P_{S-CELL}

$$P_{S-CELL} = N_{S-CELL} * (P_{AC5} + \alpha_1 / 2 * P_{AC6}) * F_{CLK}$$

N_{S-CELL} is the number of VersaTiles used as sequential modules in the design. When a multi-tile sequential cell is used, it should be accounted for as 1.

α_1 is the toggle rate of VersaTile outputs—guidelines are provided in [Table 2-12 on page 2-10](#).

F_{CLK} is the global clock signal frequency.

Combinatorial Cells Contribution— P_{C-CELL}

$$P_{C-CELL} = N_{C-CELL} * \alpha_1 / 2 * P_{AC7} * F_{CLK}$$

N_{C-CELL} is the number of VersaTiles used as combinatorial modules in the design.

α_1 is the toggle rate of VersaTile outputs—guidelines are provided in [Table 2-12 on page 2-10](#).

F_{CLK} is the global clock signal frequency.

Routing Net Contribution— P_{NET}

$$P_{NET} = (N_{S-CELL} + N_{C-CELL}) * \alpha_1 / 2 * P_{AC8} * F_{CLK}$$

N_{S-CELL} is the number of VersaTiles used as sequential modules in the design.

N_{C-CELL} is the number of VersaTiles used as combinatorial modules in the design.

α_1 is the toggle rate of VersaTile outputs—guidelines are provided in [Table 2-12 on page 2-10](#).

F_{CLK} is the global clock signal frequency.

I/O Input Buffer Contribution— P_{INPUTS}

$$P_{INPUTS} = N_{INPUTS} * \alpha_2 / 2 * P_{AC9} * F_{CLK}$$

N_{INPUTS} is the number of I/O input buffers used in the design.

α_2 is the I/O buffer toggle rate—guidelines are provided in [Table 2-12 on page 2-10](#).

F_{CLK} is the global clock signal frequency.

I/O Output Buffer Contribution— $P_{OUTPUTS}$

$$P_{OUTPUTS} = N_{OUTPUTS} * \alpha_2 / 2 * \beta_1 * P_{AC10} * F_{CLK}$$

$N_{OUTPUTS}$ is the number of I/O output buffers used in the design.

α_2 is the I/O buffer toggle rate—guidelines are provided in [Table 2-12 on page 2-10](#).

β_1 is the I/O buffer enable rate—guidelines are provided in [Table 2-13 on page 2-10](#).

F_{CLK} is the global clock signal frequency.

RAM Contribution— P_{MEMORY}

$$P_{MEMORY} = P_{AC11} * N_{BLOCKS} * F_{READ-CLOCK} * \beta_2 + P_{AC12} * N_{BLOCK} * F_{WRITE-CLOCK} * \beta_3$$

N_{BLOCKS} is the number of RAM blocks used in the design.

$F_{READ-CLOCK}$ is the memory read clock frequency.

β_2 is the RAM enable rate for read operations.

$F_{WRITE-CLOCK}$ is the memory write clock frequency.

β_3 is the RAM enable rate for write operations—guidelines are provided in [Table 2-13 on page 2-10](#).

PLL Contribution— P_{PLL}

$$P_{PLL} = P_{DC4} + P_{AC13} * F_{CLKOUT}$$

F_{CLKOUT} is the output clock frequency.¹

1. The PLL dynamic contribution depends on the input clock frequency, the number of output clock signals generated by the PLL, and the frequency of each output clock. If a PLL is used to generate more than one output clock, include each output clock in the formula by adding its corresponding contribution ($P_{AC14} * F_{CLKOUT}$ product) to the total PLL contribution.

Guidelines

Toggle Rate Definition

A toggle rate defines the frequency of a net or logic element relative to a clock. It is a percentage. If the toggle rate of a net is 100%, this means that this net switches at half the clock frequency. Below are some examples:

- The average toggle rate of a shift register is 100% because all flip-flop outputs toggle at half of the clock frequency.
- The average toggle rate of an 8-bit counter is 25%:
 - Bit 0 (LSB) = 100%
 - Bit 1 = 50%
 - Bit 2 = 25%
 - ...
 - Bit 7 (MSB) = 0.78125%
 - Average toggle rate = $(100\% + 50\% + 25\% + 12.5\% + \dots + 0.78125\%) / 8$

Enable Rate Definition

Output enable rate is the average percentage of time during which tristate outputs are enabled. When nontristate output buffers are used, the enable rate should be 100%.

Table 2-12 • Toggle Rate Guidelines Recommended for Power Calculation

Component	Definition	Guideline
α_1	Toggle rate of VersaTile outputs	10%
α_2	I/O buffer toggle rate	10%

Table 2-13 • Enable Rate Guidelines Recommended for Power Calculation

Component	Definition	Guideline
β_1	I/O output buffer enable rate	100%
β_2	RAM enable rate for read operations	12.5%
β_3	RAM enable rate for write operations	12.5%

User I/O Characteristics

Timing Model

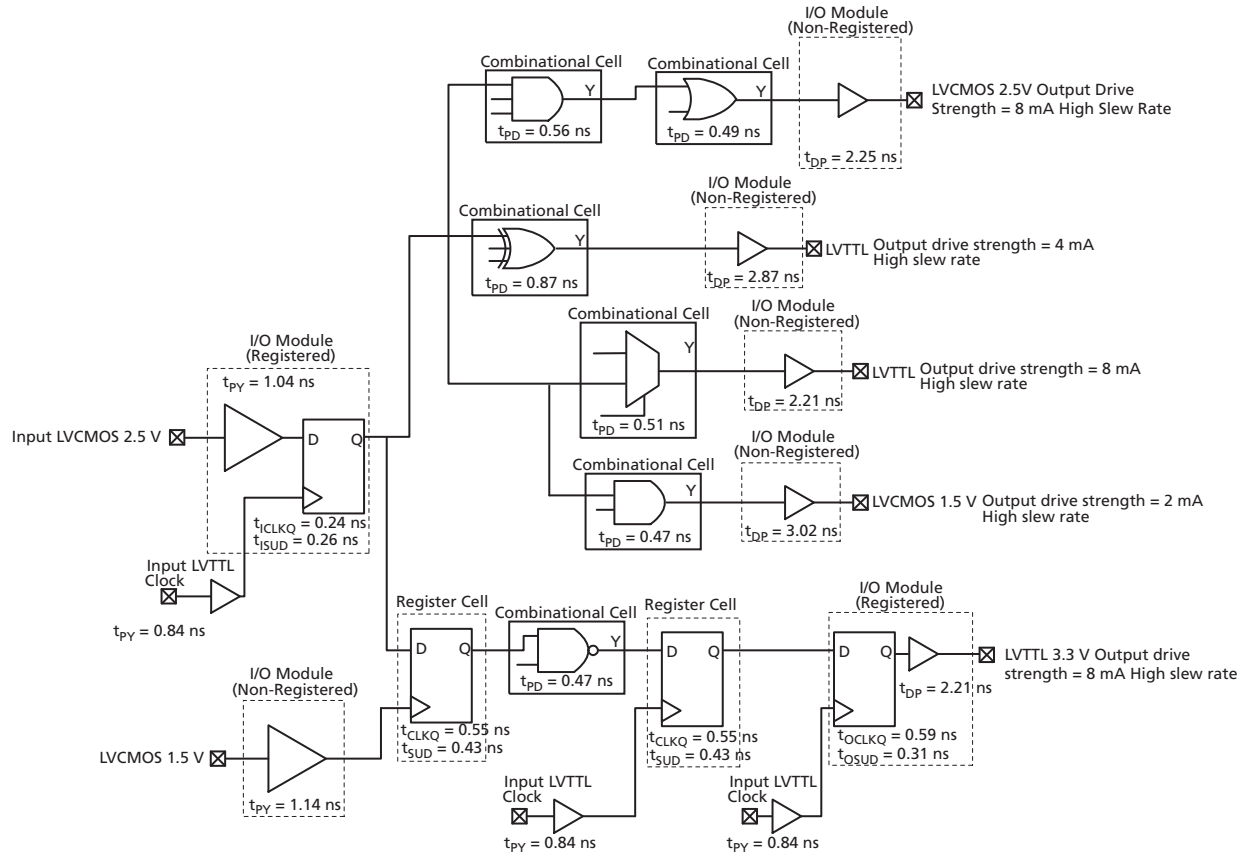

Figure 2-2 • Timing Model
 Operating Conditions: -2 Speed, Commercial Temperature Range ($T_j = 70^\circ\text{C}$), Worst Case
 $V_{CC} = 1.425$ V, with Default Loading at 10 pF

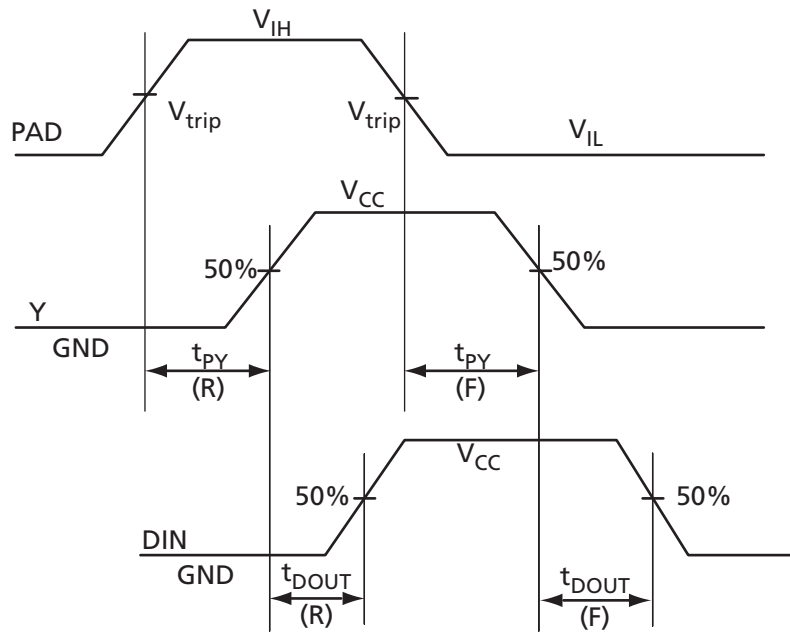
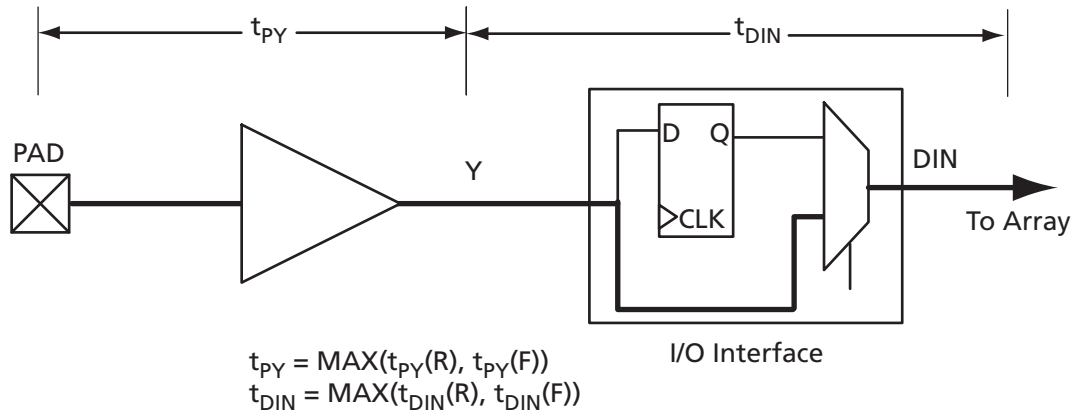

Figure 2-3 • Input Buffer Timing Model and Delays (example)

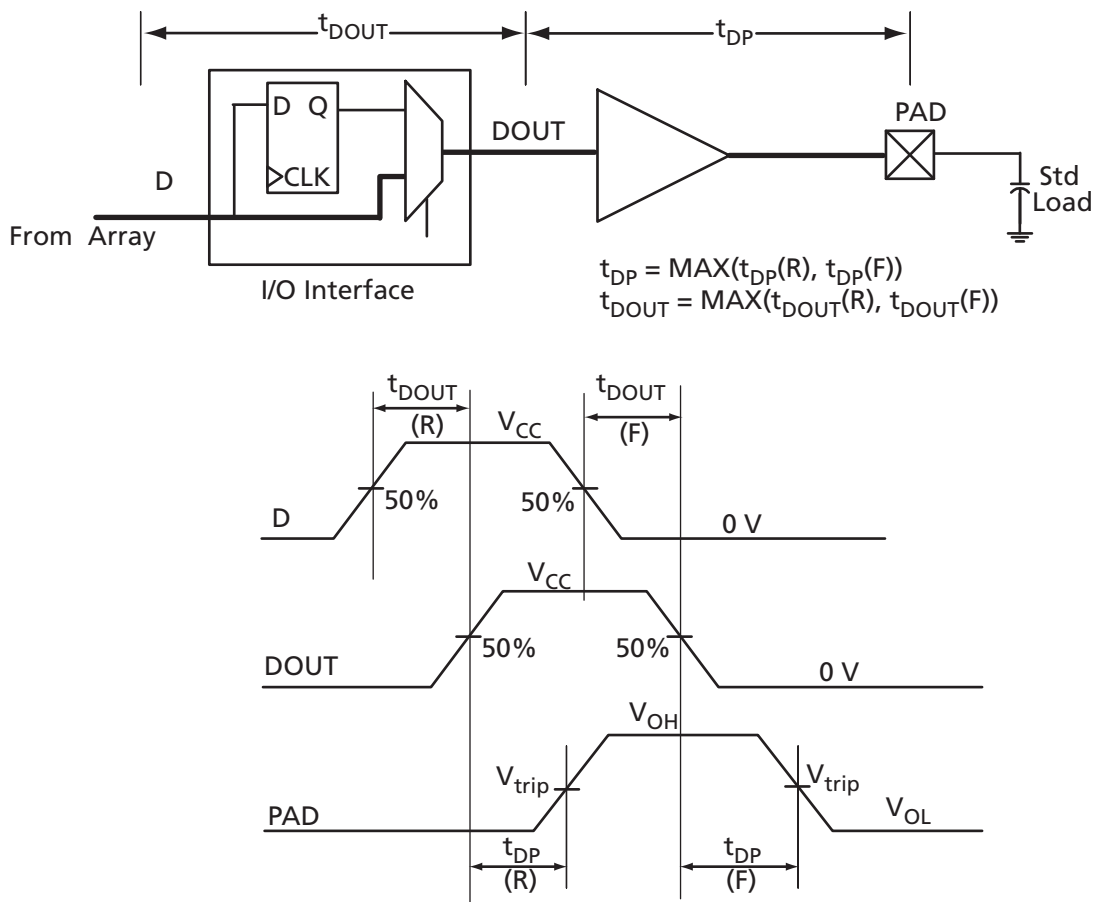

Figure 2-4 • Output Buffer Model and Delays (example)

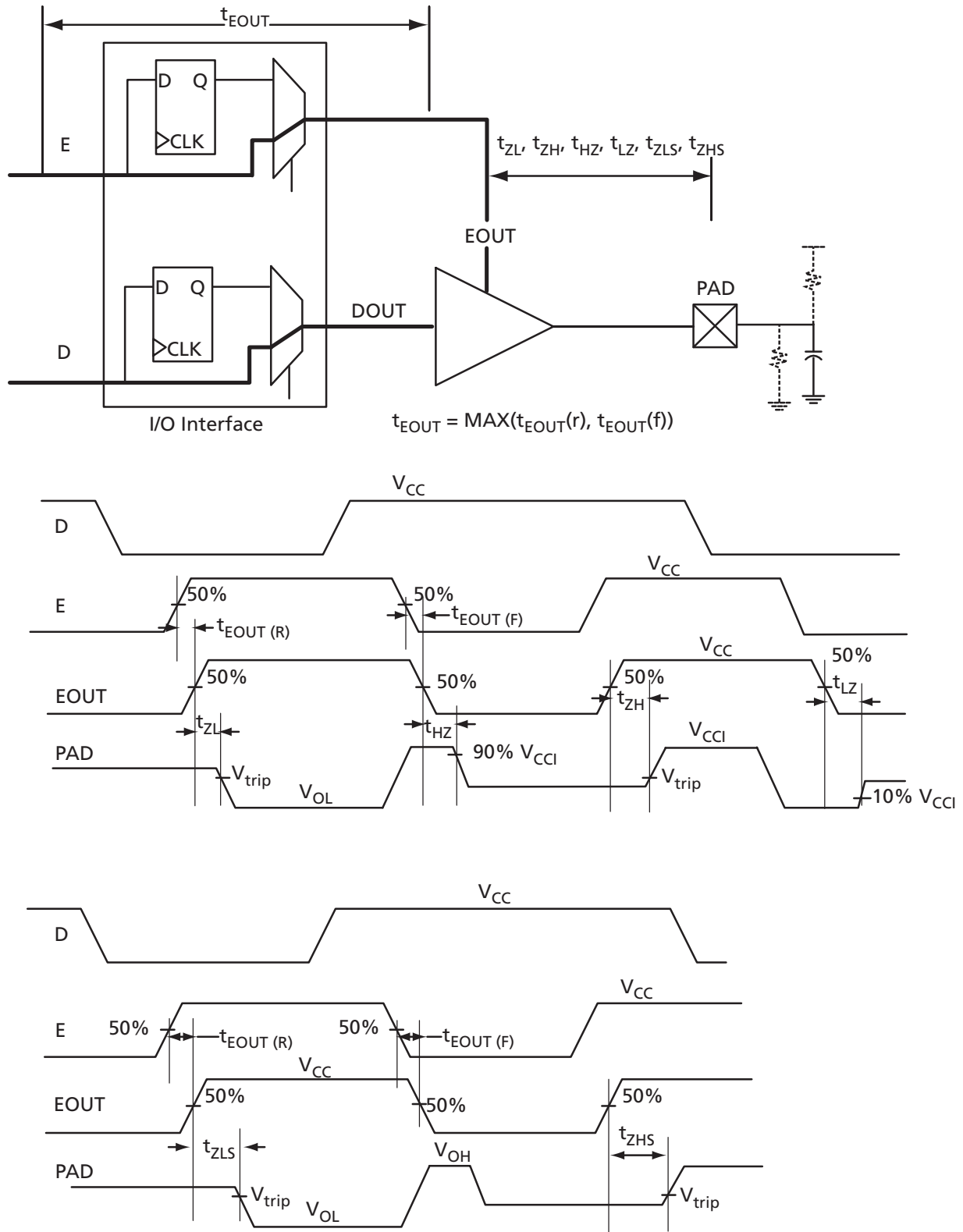

Figure 2-5 • Tristate Output Buffer Timing Model and Delays (example)

Overview of I/O Performance

Summary of I/O DC Input and Output Levels – Default I/O Software Settings

**Table 2-14 • Summary of Maximum and Minimum DC Input and Output Levels
Applicable to Commercial and Industrial Conditions—Software Default Settings**

I/O Standard	Drive Strength	Slew Rate	V_{IL}		V_{IH}		V_{OL}	V_{OH}	I_{OL}^1	I_{OH}^1
			Min, V	Max, V	Min, V	Max, V	Max, V	Min, V	mA	mA
3.3 V LVTTTL / 3.3 V LVCMOS	8 mA	High	-0.3	0.8	2	3.6	0.4	2.4	8	8
3.3 V LVCMOS Wide Range	Any ²	High	-0.3	0.8	2	3.6	0.2	$V_{CC1} - 0.2$	100 μ A	100 μ A
2.5 V LVCMOS	8 mA	High	-0.3	0.7	1.7	3.6	0.7	1.7	8	8
1.8 V LVCMOS	4 mA	High	-0.3	$0.35 * V_{CC1}$	$0.65 * V_{CC1}$	3.6	0.45	$V_{CC1} - 0.45$	4	4
1.5 V LVCMOS	2 mA	High	-0.3	$0.35 * V_{CC1}$	$0.65 * V_{CC1}$	3.6	$0.25 * V_{CC1}$	$0.75 * V_{CC1}$	2	2

Notes:

1. Currents are measured at 85°C junction temperature.
2. All LVCMOS 3.3 V software macros support LVCMOS 3.3 V wide range, as specified in the JESD8-B specification.

**Table 2-15 • Summary of Maximum and Minimum DC Input Levels
Applicable to Commercial and Industrial Conditions**

DC I/O Standards	Commercial ¹		Industrial ²	
	I_{IL}^3	I_{IH}^4	I_{IL}^3	I_{IH}^4
	μ A	μ A	μ A	μ A
3.3 V LVTTTL / 3.3 V LVCMOS	10	10	15	15
3.3 V LVCMOS Wide Range	10	10	15	15
2.5 V LVCMOS	10	10	15	15
1.8 V LVCMOS	10	10	15	15
1.5 V LVCMOS	10	10	15	15

Notes:

1. Commercial range ($-20^{\circ}\text{C} < T_A < 70^{\circ}\text{C}$)
2. Industrial range ($-40^{\circ}\text{C} < T_A < 85^{\circ}\text{C}$)
3. I_{IL} is the input leakage current per I/O pin over recommended operation conditions where $-0.3 \text{ V} < V_{IN} < V_{IL}$.
4. I_{IH} is the input leakage current per I/O pin over recommended operating conditions $V_{IH} < V_{IN} < V_{CC1}$. Input current is larger when operating outside recommended ranges.

Summary of I/O Timing Characteristics – Default I/O Software Settings

Table 2-16 • Summary of AC Measuring Points

Standard	Measuring Trip Point (V_{trip})
3.3 V LVTTTL / 3.3 V LVCMOS	1.4 V
3.3 V LVCMOS Wide Range	1.4 V
2.5 V LVCMOS	1.2 V
1.8 V LVCMOS	0.90 V
1.5 V LVCMOS	0.75 V

Table 2-17 • I/O AC Parameter Definitions

Parameter	Parameter Definition
t_{DP}	Data to Pad delay through the Output Buffer
t_{PY}	Pad to Data delay through the Input Buffer
t_{DOUT}	Data to Output Buffer delay through the I/O interface
t_{EOUT}	Enable to Output Buffer Tristate Control delay through the I/O interface
t_{DIN}	Input Buffer to Data delay through the I/O interface
t_{HZ}	Enable to Pad delay through the Output Buffer—HIGH to Z
t_{ZH}	Enable to Pad delay through the Output Buffer—Z to HIGH
t_{LZ}	Enable to Pad delay through the Output Buffer—LOW to Z
t_{ZL}	Enable to Pad delay through the Output Buffer—Z to LOW
t_{ZHS}	Enable to Pad delay through the Output Buffer with delayed enable—Z to HIGH
t_{ZLS}	Enable to Pad delay through the Output Buffer with delayed enable—Z to LOW

Table 2-18 • Summary of I/O Timing Characteristics—Software Default Settings (at 35 pF)
 STD Speed Grade, Commercial-Case Conditions: $T_J = 70^\circ\text{C}$, Worst Case $V_{CC} = 1.425\text{ V}$
 For A3PN060, A3PN125, and A3PN250

I/O Standard	Drive Strength (mA)	Slew Rate	Capacitive Load (pF)	t_{POUT} (ns)	t_{PP} (ns)	t_{DIN} (ns)	t_{PY} (ns)	t_{PYS} (ns)	t_{EOUT} (ns)	t_{ZL} (ns)	t_{ZH} (ns)	t_{LZ} (ns)	t_{HZ} (ns)
3.3 V LVTTTL / 3.3 V LVCMOS	8	High	35	0.60	4.85	0.04	1.12	TBD	0.43	4.17	3.40	2.69	3.14
3.3 V LVCMOS Wide Range	Any ¹	High	35	TBD	TBD	TBD	TBD	TBD	TBD	TBD	TBD	TBD	TBD
2.5 V LVCMOS	8	High	35	0.60	5.11	0.04	1.39	TBD	0.43	4.24	4.16	2.69	2.97
1.8 V LVCMOS	4	High	35	0.60	6.75	0.04	1.31	TBD	0.43	4.96	5.40	2.74	2.84
1.5 V LVCMOS	2	High	35	0.60	8.10	0.04	1.52	TBD	0.43	5.78	6.45	2.80	2.79

Notes:

1. All LVCMOS 3.3 V software macros support LVCMOS 3.3 V wide range, as specified in the JESD8-B specification.
2. For specific junction temperature and voltage supply levels, refer to [Table 2-6 on page 2-5](#) for derating values.

Table 2-19 • Summary of I/O Timing Characteristics—Software Default Settings (at 10 pF)
 STD Speed Grade, Commercial-Case Conditions: $T_J = 70^\circ\text{C}$, Worst Case $V_{CC} = 1.425\text{ V}$
 For A3PN020, A3PN015, and A3PN010

I/O Standard	Drive Strength (mA)	Slew Rate	Capacitive Load (pF)	t_{POUT} (ns)	t_{PP} (ns)	t_{DIN} (ns)	t_{PY} (ns)	t_{PYS} (ns)	t_{EOUT} (ns)	t_{ZL} (ns)	t_{ZH} (ns)	t_{LZ} (ns)	t_{HZ} (ns)
3.3 V LVTTTL / 3.3 V LVCMOS	8	High	10	0.60	2.97	0.04	1.12	1.51	0.43	2.60	2.02	2.69	3.14
3.3 V LVCMOS Wide Range	Any ¹	High	10	TBD	TBD	TBD	TBD	TBD	TBD	TBD	TBD	TBD	TBD
2.5 V LVCMOS	8	High	10	0.60	3.01	0.04	1.39	1.61	0.43	2.64	2.25	2.69	2.97
1.8 V LVCMOS	4	High	10	0.60	3.49	0.04	1.31	1.89	0.43	3.04	2.70	2.74	2.84
1.5 V LVCMOS	2	High	10	0.60	4.04	0.04	1.52	2.14	0.43	3.50	3.11	2.80	2.79

Notes:

1. All LVCMOS 3.3 V software macros support LVCMOS 3.3 V wide range, as specified in the JESD8-B specification.
2. For specific junction temperature and voltage supply levels, refer to [Table 2-6 on page 2-5](#) for derating values.

Detailed I/O DC Characteristics

Table 2-20 • Input Capacitance

Symbol	Definition	Conditions	Min.	Max.	Units
C_{IN}	Input capacitance	$V_{IN} = 0, f = 1.0 \text{ MHz}$		8	pF
C_{INCLK}	Input capacitance on the clock pin	$V_{IN} = 0, f = 1.0 \text{ MHz}$		8	pF

Table 2-21 • I/O Output Buffer Maximum Resistances¹

Standard	Drive Strength	$R_{PULL-DOWN}$ (Ω) ²	$R_{PULL-UP}$ (Ω) ³
3.3 V LVTTTL / 3.3 V LVCMOS	2 mA	100	300
	4 mA	100	300
	6 mA	50	150
	8 mA	50	150
3.3 V LVCMOS Wide Range	100 μ A	TBD	TBD
2.5 V LVCMOS	2 mA	100	200
	4 mA	100	200
	6 mA	50	100
	8 mA	50	100
1.8 V LVCMOS	2 mA	200	225
	4 mA	100	112
1.5 V LVCMOS	2 mA	200	224

Notes:

1. These maximum values are provided for informational reasons only. Minimum output buffer resistance values depend on V_{CC} , drive strength selection, temperature, and process. For board design considerations and detailed output buffer resistances, use the corresponding IBIS models located on the Actel website at <http://www.actel.com/download/libis/default.aspx>.
2. $R_{(PULL-DOWN-MAX)} = (V_{OLspec}) / I_{OLspec}$
3. $R_{(PULL-UP-MAX)} = (V_{CCImax} - V_{OHspec}) / I_{OHspec}$

**Table 2-22 • I/O Weak Pull-Up/Pull-Down Resistances
Minimum and Maximum Weak Pull-Up/Pull-Down Resistance Values**

V_{CC}	$R_{(WEAK PULL-UP)}$ ¹ (Ω)		$R_{(WEAK PULL-DOWN)}$ ² (Ω)	
	Min.	Max.	Min.	Max.
3.3 V	10 k	45 k	10 k	45 k
2.5 V	11 k	55 k	12 k	74 k
1.8 V	18 k	70 k	17 k	110 k
1.5 V	19 k	90 k	19 k	140 k

Notes:

1. $R_{(WEAK PULL-UP-MAX)} = (V_{OLspec}) / I_{(WEAK PULL-UP-MIN)}$
2. $R_{(WEAK PULL-UP-MAX)} = (V_{CCImax} - V_{OHspec}) / I_{(WEAK PULL-UP-MIN)}$

Table 2-23 • I/O Short Currents I_{OSH}/I_{OSL}

	Drive Strength	I_{OSL} (mA)*	I_{OSH} (mA)*
3.3 V LVTTTL / 3.3 V LVCMOS	2 mA	25	27
	4 mA	25	27
	6 mA	51	54
	8 mA	51	54
3.3 V LVCMOS Wide Range	100 μ A	TBD	TBD
2.5 V LVCMOS	2 mA	16	18
	4 mA	16	18
	6 mA	32	37
	8 mA	32	37
1.8 V LVCMOS	2 mA	9	11
	4 mA	17	22
1.5 V LVCMOS	2 mA	13	16

* $T_J = 100^\circ\text{C}$

The length of time an I/O can withstand I_{OSH}/I_{OSL} events depends on the junction temperature. The reliability data below is based on a 3.3 V, 8 mA I/O setting, which is the worst case for this type of analysis.

For example, at 110°C , the short current condition would have to be sustained for more than three months to cause a reliability concern. The I/O design does not contain any short circuit protection, but such protection would only be needed in extremely prolonged stress conditions.

Table 2-24 • Duration of Short Circuit Event before Failure

Temperature	Time before Failure
-40°C	> 20 years
-20°C	> 20 years
0°C	> 20 years
25°C	> 20 years
70°C	5 years
85°C	2 years
100°C	6 months
110°C	3 months

**Table 2-25 • Schmitt Trigger Input Hysteresis
Hysteresis Voltage Value (Typ.) for Schmitt Mode Input Buffers**

Input Buffer Configuration	Hysteresis Value (typ.)
3.3 V LVTTTL / LVCMOS (Schmitt trigger mode)	240 mV
2.5 V LVCMOS (Schmitt trigger mode)	140 mV
1.8 V LVCMOS (Schmitt trigger mode)	80 mV
1.5 V LVCMOS (Schmitt trigger mode)	60 mV

Table 2-26 • I/O Input Rise Time, Fall Time, and Related I/O Reliability

Input Buffer	Input Rise/Fall Time (min.)	Input Rise/Fall Time (max.)	Reliability
LVTTTL/LVCMOS	No requirement	10 ns *	20 years (110°C)

* The maximum input rise/fall time is related to the noise induced into the input buffer trace. If the noise is low, then the rise time and fall time of input buffers can be increased beyond the maximum value. The longer the rise/fall times, the more susceptible the input signal is to the board noise. Actel recommends signal integrity evaluation/characterization of the system to ensure that there is no excessive noise coupling into input signals.

Single-Ended I/O Characteristics

3.3 V LVTTTL / 3.3 V LVCMOS

Low-Voltage Transistor–Transistor Logic (LVTTTL) is a general-purpose standard (EIA/JESD) for 3.3 V applications. It uses an LVTTTL input buffer and push-pull output buffer.

Table 2-27 • Minimum and Maximum DC Input and Output Levels

3.3 V LVTTTL / 3.3 V LVCMOS	V_{IL}		V_{IH}		V_{OL}	V_{OH}	I_{OL}	I_{OH}	I_{OSL}	I_{OSH}	I_{I1}	I_{I2}
	Min., V	Max., V	Min., V	Max., V	Max., V	Min., V	m A	m A	Max., mA ³	Max., mA ³	μ A ⁴	μ A ⁴
2 mA	-0.3	0.8	2	3.6	0.4	2.4	2	2	25	27	10	10
4 mA	-0.3	0.8	2	3.6	0.4	2.4	4	4	25	27	10	10
6 mA	-0.3	0.8	2	3.6	0.4	2.4	6	6	51	54	10	10
8 mA	-0.3	0.8	2	3.6	0.4	2.4	8	8	51	54	10	10

Notes:

1. I_{IL} is the input leakage current per I/O pin over recommended operation conditions where $-0.3\text{ V} < V_{IN} < V_{IL}$.
2. I_{IH} is the input leakage current per I/O pin over recommended operating conditions $V_{IH} < V_{IN} < V_{CCI}$. Input current is larger when operating outside recommended ranges.
3. Currents are measured at high temperature (100°C junction temperature) and maximum voltage.
4. Currents are measured at 85°C junction temperature.
5. Software default selection highlighted in gray.

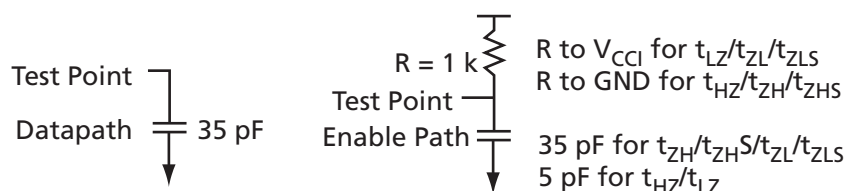

Figure 2-6 • AC Loading

Table 2-28 • 3.3 V LVTTTL/LVCMOS AC Waveforms, Measuring Points, and Capacitive Loads

Input LOW (V)	Input HIGH (V)	Measuring Point* (V)	C_{LOAD} (pF)
0	3.3	1.4	10

Notes:

1. Measuring point = V_{trip} . See Table 2-16 on page 2-16 for a complete table of trip points.
2. Capacitive Load for A3PN060, A3PN125, and A3PN250 is 35 pF.

Timing Characteristics

Table 2-29 • 3.3 V LVTTTL / 3.3 V LVCMOS Low Slew
 Commercial-Case Conditions: $T_J = 70^\circ\text{C}$, Worst-Case $V_{CC} = 1.425\text{ V}$, Worst-Case $V_{CCI} = 3.0\text{ V}$
 Software Default Load at 35 pF for A3PN060, A3PN125, A3PN250

Drive Strength	Speed Grade	t_{DOUT}	t_{DP}	t_{DIN}	t_{PY}	t_{PYS}	t_{EOUT}	t_{ZL}	t_{ZH}	t_{LZ}	t_{HZ}	Units
2 mA	Std.	0.60	10.48	0.04	1.12	TBD	0.43	8.86	7.41	2.40	2.47	ns
	-1	0.51	8.91	0.04	0.95	TBD	0.36	7.54	6.30	2.04	2.10	ns
	-2	0.45	7.83	0.03	0.84	TBD	0.32	6.62	5.53	1.79	1.84	ns
4 mA	Std.	0.60	10.48	0.04	1.12	TBD	0.43	8.86	7.41	2.40	2.47	ns
	-1	0.51	8.91	0.04	0.95	TBD	0.36	7.54	6.30	2.04	2.10	ns
	-2	0.45	7.83	0.03	0.84	TBD	0.32	6.62	5.53	1.79	1.84	ns
6 mA	Std.	0.60	7.45	0.04	1.12	TBD	0.43	6.48	5.53	2.69	3.00	ns
	-1	0.51	6.33	0.04	0.95	TBD	0.36	5.51	4.70	2.29	2.55	ns
	-2	0.45	5.56	0.03	0.84	TBD	0.32	4.84	4.13	2.01	2.24	ns
8 mA	Std.	0.60	7.45	0.04	1.12	TBD	0.43	6.48	5.53	2.69	3.00	ns
	-1	0.51	6.33	0.04	0.95	TBD	0.36	5.51	4.70	2.29	2.55	ns
	-2	0.45	5.56	0.03	0.84	TBD	0.32	4.84	4.13	2.01	2.24	ns

Note: For specific junction temperature and voltage supply levels, refer to [Table 2-6 on page 2-5](#) for derating values.

Table 2-30 • 3.3 V LVTTTL / 3.3 V LVCMOS High Slew
 Commercial-Case Conditions: $T_J = 70^\circ\text{C}$, Worst-Case $V_{CC} = 1.425\text{ V}$, Worst-Case $V_{CCI} = 3.0\text{ V}$
 Software Default Load at 35 pF for A3PN060, A3PN125, A3PN250

Drive Strength	Speed Grade	t_{DOUT}	t_{DP}	t_{DIN}	t_{PY}	t_{PYS}	t_{EOUT}	t_{ZL}	t_{ZH}	t_{LZ}	t_{HZ}	Units
2 mA	Std.	0.60	7.53	0.04	1.12	TBD	0.43	6.15	5.18	2.39	2.61	ns
	-1	0.51	6.41	0.04	0.95	TBD	0.36	5.23	4.41	2.04	2.22	ns
	-2	0.45	5.63	0.03	0.84	TBD	0.32	4.60	3.87	1.79	1.95	ns
4 mA	Std.	0.60	7.53	0.04	1.12	TBD	0.43	6.15	5.18	2.39	2.61	ns
	-1	0.51	6.41	0.04	0.95	TBD	0.36	5.23	4.41	2.04	2.22	ns
	-2	0.45	5.63	0.03	0.84	TBD	0.32	4.60	3.87	1.79	1.95	ns
6 mA	Std.	0.60	4.85	0.04	1.12	TBD	0.43	4.17	3.40	2.69	3.14	ns
	-1	0.51	4.13	0.04	0.95	TBD	0.36	3.55	2.89	2.29	2.67	ns
	-2	0.45	3.63	0.03	0.84	TBD	0.32	3.11	2.54	2.01	2.34	ns
8 mA	Std.	0.60	4.85	0.04	1.12	TBD	0.43	4.17	3.40	2.69	3.14	ns
	-1	0.51	4.13	0.04	0.95	TBD	0.36	3.55	2.89	2.29	2.67	ns
	-2	0.45	3.63	0.03	0.84	TBD	0.32	3.11	2.54	2.01	2.34	ns

Notes:

1. Software default selection highlighted in gray.
2. For specific junction temperature and voltage supply levels, refer to [Table 2-6 on page 2-5](#) for derating values.

Table 2-31 • 3.3 V LVTTTL / 3.3 V LVCMOS Low Slew

Commercial-Case Conditions: $T_J = 70^\circ\text{C}$, Worst-Case $V_{CC} = 1.425\text{ V}$, Worst-Case $V_{CCI} = 3.0\text{ V}$
 Software Default Load at 10 pF for A3PN020, A3PN015, A3PN010

Drive Strength	Speed Grade	t_{DOUT}	t_{DP}	t_{DIN}	t_{PY}	t_{PYS}	t_{EOUT}	t_{ZL}	t_{ZH}	t_{LZ}	t_{HZ}	Units
2 mA	Std.	0.60	6.08	0.04	1.12	1.51	0.43	5.20	4.48	2.40	2.47	ns
	-1	0.51	5.17	0.04	0.95	1.28	0.36	4.43	3.81	2.04	2.10	ns
	-2	0.45	4.54	0.03	0.84	1.13	0.32	3.88	3.35	1.79	1.84	ns
4 mA	Std.	0.60	6.08	0.04	1.12	1.51	0.43	5.20	4.48	2.40	2.47	ns
	-1	0.51	5.17	0.04	0.95	1.28	0.36	4.43	3.81	2.04	2.10	ns
	-2	0.45	4.54	0.03	0.84	1.13	0.32	3.88	3.35	1.79	1.84	ns
6 mA	Std.	0.60	4.76	0.04	1.12	1.51	0.43	4.25	3.83	2.69	3.00	ns
	-1	0.51	4.05	0.04	0.95	1.28	0.36	3.61	3.26	2.29	2.55	ns
	-2	0.45	3.56	0.03	0.84	1.13	0.32	3.17	2.86	2.01	2.24	ns
8 mA	Std.	0.60	4.76	0.04	1.12	1.51	0.43	4.25	3.83	2.69	3.00	ns
	-1	0.51	4.05	0.04	0.95	1.28	0.36	3.61	3.26	2.29	2.55	ns
	-2	0.45	3.56	0.03	0.84	1.13	0.32	3.17	2.86	2.01	2.24	ns

Note: For specific junction temperature and voltage supply levels, refer to Table 2-6 on page 2-5 for derating values.

Table 2-32 • 3.3 V LVTTTL / 3.3 V LVCMOS High Slew

Commercial-Case Conditions: $T_J = 70^\circ\text{C}$, Worst-Case $V_{CC} = 1.425\text{ V}$, Worst-Case $V_{CCI} = 3.0\text{ V}$
 Software Default Load at 10 pF for A3PN020, A3PN015, A3PN010

Drive Strength	Speed Grade	t_{DOUT}	t_{DP}	t_{DIN}	t_{PY}	t_{PYS}	t_{EOUT}	t_{ZL}	t_{ZH}	t_{LZ}	t_{HZ}	Units
2 mA	Std.	0.60	3.84	0.04	1.12	1.51	0.43	3.09	2.44	2.39	2.61	ns
	-1	0.51	3.27	0.04	0.95	1.28	0.36	2.63	2.07	2.04	2.22	ns
	-2	0.45	2.87	0.03	0.84	1.13	0.32	2.31	1.82	1.79	1.95	ns
4 mA	Std.	0.60	3.84	0.04	1.12	1.51	0.43	3.09	2.44	2.39	2.61	ns
	-1	0.51	3.27	0.04	0.95	1.28	0.36	2.63	2.07	2.04	2.22	ns
	-2	0.45	2.87	0.03	0.84	1.13	0.32	2.31	1.82	1.79	1.95	ns
6 mA	Std.	0.60	2.97	0.04	1.12	1.51	0.43	2.60	2.02	2.69	3.14	ns
	-1	0.51	2.52	0.04	0.95	1.28	0.36	2.21	1.72	2.29	2.67	ns
	-2	0.45	2.21	0.03	0.84	1.13	0.32	1.94	1.51	2.01	2.34	ns
8 mA	Std.	0.60	2.97	0.04	1.12	1.51	0.43	2.60	2.02	2.69	3.14	ns
	-1	0.51	2.52	0.04	0.95	1.28	0.36	2.21	1.72	2.29	2.67	ns
	-2	0.45	2.21	0.03	0.84	1.13	0.32	1.94	1.51	2.01	2.34	ns

Notes:

1. Software default selection highlighted in gray.
2. For specific junction temperature and voltage supply levels, refer to Table 2-6 on page 2-5 for derating values.

3.3 V LVCMOS Wide Range

Table 2-33 • Minimum and Maximum DC Input and Output Levels for 3.3 V LVCMOS Wide Range

3.3 V LVCMOS Wide Range	V_{IL}		V_{IH}		V_{OL}	V_{OH}	I_{OL}	I_{OH}	I_{IL}^1	I_{IH}^2
	Min., V	Max., V	Min., V	Max., V	Max., V	Min., V	mA	mA	μA^4	μA^4
Any ³	-0.3	0.8	2	3.6	0.2	$V_{DD} - 0.2$	100	100	10	10

Notes:

1. I_{IL} is the input leakage current per I/O pin over recommended operation conditions where $-0.3\text{ V} < V_{IN} < V_{IL}$.
2. I_{IH} is the input leakage current per I/O pin over recommended operating conditions $V_{IH} < V_{IN} < V_{CCI}$. Input current is larger when operating outside recommended ranges.
3. All LVCMOS 3.3 V software macros support LVCMOS 3.3 V Wide Range, as specified in the JESD8-B specification.
4. Currents are measured at 85°C junction temperature.

2.5 V LVCMOS

Low-Voltage CMOS for 2.5 V is an extension of the LVCMOS standard (JESD8-5) used for general-purpose 2.5 V applications. It uses a 5 V-tolerant input buffer and push-pull output buffer.

Table 2-34 • Minimum and Maximum DC Input and Output Levels

2.5 V LVCMOS	V_{IL}		V_{IH}		V_{OL}	V_{OH}	I_{OL}	I_{OH}	I_{OSL}	I_{OSH}	I_{IL}	I_{IH}
	Min., V	Max., V	Min., V	Max., V	Max., V	Min., V	m A	m A	Max., mA ³	Max., mA ³	μ A ₄	μ A ₄
2 mA	-0.3	0.7	1.7	3.6	0.7	1.7	2	2	16	18	10	10
4 mA	-0.3	0.7	1.7	3.6	0.7	1.7	4	4	16	18	10	10
6 mA	-0.3	0.7	1.7	3.6	0.7	1.7	6	6	32	37	10	10
8 mA	-0.3	0.7	1.7	3.6	0.7	1.7	8	8	32	37	10	10

Notes:

1. I_{IL} is the input leakage current per I/O pin over recommended operation conditions where $-0.3\text{ V} < V_{IN} < V_{IL}$.
2. I_{IH} is the input leakage current per I/O pin over recommended operating conditions $V_{IH} < V_{IN} < V_{CCI}$. Input current is larger when operating outside recommended ranges.
3. Currents are measured at high temperature (100°C junction temperature) and maximum voltage.
4. Currents are measured at 85°C junction temperature.
5. Software default selection highlighted in gray.

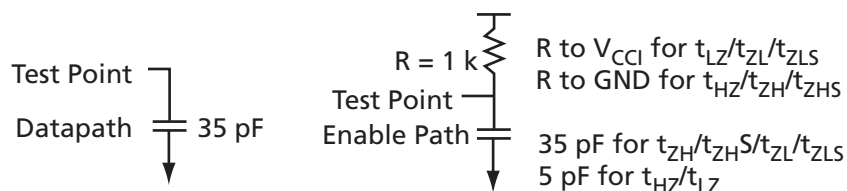

Figure 2-7 • AC Loading

Table 2-35 • 2.5 V LVCMOS AC Waveforms, Measuring Points, and Capacitive Loads

Input LOW (V)	Input HIGH (V)	Measuring Point* (V)	C_{LOAD} (pF)
0	2.5	1.2	10

Notes:

1. Measuring point = V_{trip} . See [Table 2-16 on page 2-16](#) for a complete table of trip points.
2. Capacitive Load for A3PN060, A3PN125, and A3PN250 is 35 pF.

Timing Characteristics
Table 2-36 • 2.5 V LVCMOS Low Slew

 Commercial-Case Conditions: $T_J = 70^\circ\text{C}$, Worst-Case $V_{CC} = 1.425\text{ V}$, Worst-Case $V_{CCI} = 2.3\text{ V}$
 Software Default Load at 35 pF for A3PN060, A3PN125, A3PN250

Drive Strength	Speed Grade	t_{DOUT}	t_{DP}	t_{DIN}	t_{PY}	t_{PYS}	t_{EOUT}	t_{ZL}	t_{ZH}	t_{LZ}	t_{HZ}	Units
2 mA	Std.	0.60	11.40	0.04	1.39	TBD	0.43	9.71	9.33	2.37	2.25	ns
	-1	0.51	9.70	0.04	1.19	TBD	0.36	8.26	7.94	2.02	1.91	ns
	-2	0.45	8.51	0.03	1.04	TBD	0.32	7.25	6.97	1.77	1.68	ns
4 mA	Std.	0.60	11.40	0.04	1.39	TBD	0.43	9.71	9.33	2.37	2.25	ns
	-1	0.51	9.70	0.04	1.19	TBD	0.36	8.26	7.94	2.02	1.91	ns
	-2	0.45	8.51	0.03	1.04	TBD	0.32	7.25	6.97	1.77	1.68	ns
6 mA	Std.	0.60	8.24	0.04	1.39	TBD	0.43	7.20	6.77	2.70	2.87	ns
	-1	0.51	7.01	0.04	1.19	TBD	0.36	6.13	5.76	2.30	2.44	ns
	-2	0.45	6.15	0.03	1.04	TBD	0.32	5.38	5.05	2.01	2.14	ns
8 mA	Std.	0.60	8.24	0.04	1.39	TBD	0.43	7.20	6.77	2.70	2.87	ns
	-1	0.51	7.01	0.04	1.19	TBD	0.36	6.13	5.76	2.30	2.44	ns
	-2	0.45	6.15	0.03	1.04	TBD	0.32	5.38	5.05	2.01	2.14	ns

Note: For specific junction temperature and voltage supply levels, refer to Table 2-6 on page 2-5 for derating values.

Table 2-37 • 2.5 V LVCMOS High Slew

 Commercial-Case Conditions: $T_J = 70^\circ\text{C}$, Worst-Case $V_{CC} = 1.425\text{ V}$, Worst-Case $V_{CCI} = 2.3\text{ V}$
 Software Default Load at 35 pF for A3PN060, A3PN125, A3PN250

Drive Strength	Speed Grade	t_{DOUT}	t_{DP}	t_{DIN}	t_{PY}	t_{PYS}	t_{EOUT}	t_{ZL}	t_{ZH}	t_{LZ}	t_{HZ}	Units
2 mA	Std.	0.60	8.54	0.04	1.39		0.43	6.25	6.65	2.37	2.34	ns
	-1	0.51	7.26	0.04	1.19		0.36	5.31	5.66	2.01	1.99	ns
	-2	0.45	6.38	0.03	1.04		0.32	4.66	4.97	1.77	1.75	ns
4 mA	Std.	0.60	8.54	0.04	1.39		0.43	6.25	6.65	2.37	2.34	ns
	-1	0.51	7.26	0.04	1.19		0.36	5.31	5.66	2.01	1.99	ns
	-2	0.45	6.38	0.03	1.04		0.32	4.66	4.97	1.77	1.75	ns
6 mA	Std.	0.60	5.11	0.04	1.39		0.43	4.24	4.16	2.69	2.97	ns
	-1	0.51	4.35	0.04	1.19		0.36	3.61	3.54	2.29	2.53	ns
	-2	0.45	3.82	0.03	1.04		0.32	3.17	3.11	2.01	2.22	ns
8 mA	Std.	0.60	5.11	0.04	1.39		0.43	4.24	4.16	2.69	2.97	ns
	-1	0.51	4.35	0.04	1.19		0.36	3.61	3.54	2.29	2.53	ns
	-2	0.45	3.82	0.03	1.04		0.32	3.17	3.11	2.01	2.22	ns

Notes:

1. Software default selection highlighted in gray.
2. For specific junction temperature and voltage supply levels, refer to Table 2-6 on page 2-5 for derating values.

Table 2-38 • 2.5 V LVCMOS Low Slew

 Commercial-Case Conditions: $T_J = 70^\circ\text{C}$, Worst-Case $V_{CC} = 1.425\text{ V}$, Worst-Case $V_{CCI} = 2.3\text{ V}$
 Software Default Load at 10 pF for A3PN020, A3PN015, A3PN010

Drive Strength	Speed Grade	t_{DOUT}	t_{DP}	t_{DIN}	t_{PY}	t_{PYS}	t_{EOUT}	t_{ZL}	t_{ZH}	t_{LZ}	t_{HZ}	Units
2 mA	Std.	0.60	6.79	0.04	1.39	1.61	0.43	5.87	5.37	2.37	2.25	ns
	-1	0.51	5.77	0.04	1.19	1.37	0.36	5.00	4.56	2.02	1.91	ns
	-2	0.45	5.07	0.03	1.04	1.20	0.32	4.39	4.01	1.77	1.68	ns
4 mA	Std.	0.60	6.79	0.04	1.39	1.61	0.43	5.87	5.37	2.37	2.25	ns
	-1	0.51	5.77	0.04	1.19	1.37	0.36	5.00	4.56	2.02	1.91	ns
	-2	0.45	5.07	0.03	1.04	1.20	0.32	4.39	4.01	1.77	1.68	ns
6 mA	Std.	0.60	5.34	0.04	1.39	1.61	0.43	4.79	4.55	2.70	2.87	ns
	-1	0.51	4.55	0.04	1.19	1.37	0.36	4.08	3.87	2.30	2.44	ns
	-2	0.45	3.99	0.03	1.04	1.20	0.32	3.58	3.40	2.01	2.14	ns
8 mA	Std.	0.60	5.34	0.04	1.39	1.61	0.43	4.79	4.55	2.70	2.87	ns
	-1	0.51	4.55	0.04	1.19	1.37	0.36	4.08	3.87	2.30	2.44	ns
	-2	0.45	3.99	0.03	1.04	1.20	0.32	3.58	3.40	2.01	2.14	ns

Note: For specific junction temperature and voltage supply levels, refer to Table 2-6 on page 2-5 for derating values.

Table 2-39 • 2.5 V LVCMOS High Slew

 Commercial-Case Conditions: $T_J = 70^\circ\text{C}$, Worst-Case $V_{CC} = 1.425\text{ V}$, Worst-Case $V_{CCI} = 2.3\text{ V}$
 Software Default Load at 10 pF for A3PN020, A3PN015, A3PN010

Drive Strength	Speed Grade	t_{DOUT}	t_{DP}	t_{DIN}	t_{PY}	t_{PYS}	t_{EOUT}	t_{ZL}	t_{ZH}	t_{LZ}	t_{HZ}	Units
2 mA	Std.	0.60	3.93	0.04	1.39	1.61	0.43	3.17	2.84	2.37	2.34	ns
	-1	0.51	3.34	0.04	1.19	1.37	0.36	2.69	2.41	2.01	1.99	ns
	-2	0.45	2.93	0.03	1.04	1.20	0.32	2.36	2.12	1.77	1.75	ns
4 mA	Std.	0.60	3.93	0.04	1.39	1.61	0.43	3.17	2.84	2.37	2.34	ns
	-1	0.51	3.34	0.04	1.19	1.37	0.36	2.69	2.41	2.01	1.99	ns
	-2	0.45	2.93	0.03	1.04	1.20	0.32	2.36	2.12	1.77	1.75	ns
6 mA	Std.	0.60	3.01	0.04	1.39	1.61	0.43	2.64	2.25	2.69	2.97	ns
	-1	0.51	2.56	0.04	1.19	1.37	0.36	2.25	1.92	2.29	2.53	ns
	-2	0.45	2.25	0.03	1.04	1.20	0.32	1.97	1.68	2.01	2.22	ns
8 mA	Std.	0.60	3.01	0.04	1.39	1.61	0.43	2.64	2.25	2.69	2.97	ns
	-1	0.51	2.56	0.04	1.19	1.37	0.36	2.25	1.92	2.29	2.53	ns
	-2	0.45	2.25	0.03	1.04	1.20	0.32	1.97	1.68	2.01	2.22	ns

Notes:

1. Software default selection highlighted in gray.
2. For specific junction temperature and voltage supply levels, refer to Table 2-6 on page 2-5 for derating values.

1.8 V LVCMOS

Low-voltage CMOS for 1.8 V is an extension of the LVCMOS standard (JESD8-5) used for general-purpose 1.8 V applications. It uses a 1.8 V input buffer and a push-pull output buffer.

Table 2-40 • Minimum and Maximum DC Input and Output Levels

1.8 V LVCMOS	V_{IL}		V_{IH}		V_{OL}	V_{OH}	I_{OL}	I_{OH}	I_{OSL}	I_{OSH}	I_{I1}	I_{I2}
	Min., V	Max., V	Min., V	Max., V	Max., V	Min., V	m A	m A	Max., mA ³	Max., mA ³	μ A ₄	μ A ₄
2 mA	-0.3	0.35 * V_{CCI}	0.65 * V_{CCI}	3.6	0.45	$V_{CCI} - 0.45$	2	2	9	11	10	10
4 mA	-0.3	0.35 * V_{CCI}	0.65 * V_{CCI}	3.6	0.45	$V_{CCI} - 0.45$	4	4	17	22	10	10

Notes:

1. I_{IL} is the input leakage current per I/O pin over recommended operation conditions where $-0.3\text{ V} < V_{IN} < V_{IL}$.
2. I_{IH} is the input leakage current per I/O pin over recommended operating conditions $V_{IH} < V_{IN} < V_{CCI}$. Input current is larger when operating outside recommended ranges.
3. Currents are measured at high temperature (100°C junction temperature) and maximum voltage.
4. Currents are measured at 85°C junction temperature.
5. Software default selection highlighted in gray.

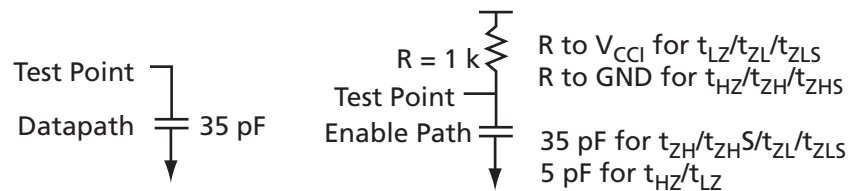

Figure 2-8 • AC Loading

Table 2-41 • 1.8 V LVCMOS AC Waveforms, Measuring Points, and Capacitive Loads

Input LOW (V)	Input HIGH (V)	Measuring Point* (V)	C_{LOAD} (pF)
0	1.8	0.9	10

Notes:

1. Measuring point = V_{trip} . See Table 2-16 on page 2-16 for a complete table of trip points.
2. Capacitive Load for A3PN060, A3PN125, and A3PN250 is 35 pF.

Timing Characteristics

Table 2-42 • 1.8 V LVCMOS Low Slew

Commercial-Case Conditions: $T_J = 70^\circ\text{C}$, Worst-Case $V_{CC} = 1.425\text{ V}$, Worst-Case $V_{CCI} = 1.7\text{ V}$
 Software Default Load at 35 pF for A3PN060, A3PN125, A3PN250

Drive Strength	Speed Grade	t_{DOUT}	t_{DP}	t_{DIN}	t_{PY}	t_{PYS}	t_{EOUT}	t_{ZL}	t_{ZH}	t_{LZ}	t_{HZ}	Units
2 mA	Std.	0.60	15.34	0.04	1.31	TBD	0.43	12.49	12.58	2.35	1.72	ns
	-1	0.51	13.05	0.04	1.12	TBD	0.36	10.63	10.70	2.00	1.46	ns
	-2	0.45	11.45	0.03	0.98	TBD	0.32	9.33	9.40	1.76	1.28	ns
4 mA	Std.	0.60	10.68	0.04	1.31	TBD	0.43	9.39	8.98	2.75	2.74	ns
	-1	0.51	9.09	0.04	1.12	TBD	0.36	7.99	7.64	2.34	2.33	ns
	-2	0.45	7.98	0.03	0.98	TBD	0.32	7.01	6.70	2.05	2.04	ns

Note: For specific junction temperature and voltage supply levels, refer to Table 2-6 on page 2-5 for derating values.

Table 2-43 • 1.8 V LVCMOS High Slew

Commercial-Case Conditions: $T_J = 70^\circ\text{C}$, Worst-Case $V_{CC} = 1.425\text{ V}$, Worst-Case $V_{CCI} = 1.7\text{ V}$
 Software Default Load at 35 pF for A3PN060, A3PN125, A3PN250

Drive Strength	Speed Grade	t_{DOUT}	t_{DP}	t_{DIN}	t_{PY}	t_{PYS}	t_{EOUT}	t_{ZL}	t_{ZH}	t_{LZ}	t_{HZ}	Units
2 mA	Std.	0.60	11.61	0.04	1.31		0.43	7.36	8.94	2.35	1.78	ns
	-1	0.51	9.88	0.04	1.12		0.36	6.26	7.60	2.00	1.51	ns
	-2	0.45	8.67	0.03	0.98		0.32	5.49	6.67	1.75	1.33	ns
4 mA	Std.	0.60	6.75	0.04	1.31		0.43	4.96	5.40	2.74	2.84	ns
	-1	0.51	5.74	0.04	1.12		0.36	4.22	4.60	2.33	2.42	ns
	-2	0.45	5.04	0.03	0.98		0.32	3.70	4.04	2.05	2.12	ns

Notes:

1. Software default selection highlighted in gray.
2. For specific junction temperature and voltage supply levels, refer to Table 2-6 on page 2-5 for derating values.

Table 2-44 • 1.8 V LVCMOS Low Slew

 Commercial-Case Conditions: $T_J = 70^\circ\text{C}$, Worst-Case $V_{CC} = 1.425\text{ V}$, Worst-Case $V_{CCI} = 1.7\text{ V}$
 Software Default Load at 10 pF for A3PN020, A3PN015, A3PN010

Drive Strength	Speed Grade	t_{DOUT}	t_{DP}	t_{DIN}	t_{PY}	t_{PYS}	t_{EOUT}	t_{ZL}	t_{ZH}	t_{LZ}	t_{HZ}	Units
2 mA	Std.	0.60	8.90	0.04	1.31	1.89	0.43	7.80	7.02	2.35	1.72	ns
	-1	0.51	7.57	0.04	1.12	1.60	0.36	6.64	5.97	2.00	1.46	ns
	-2	0.45	6.65	0.03	0.98	1.41	0.32	5.82	5.24	1.76	1.28	ns
4 mA	Std.	0.60	7.08	0.04	1.31	1.89	0.43	6.40	5.93	2.75	2.74	ns
	-1	0.51	6.02	0.04	1.12	1.60	0.36	5.44	5.05	2.34	2.33	ns
	-2	0.45	5.29	0.03	0.98	1.41	0.32	4.78	4.43	2.05	2.04	ns

Note: For specific junction temperature and voltage supply levels, refer to Table 2-6 on page 2-5 for derating values.

Table 2-45 • 1.8 V LVCMOS High Slew

 Commercial-Case Conditions: $T_J = 70^\circ\text{C}$, Worst-Case $V_{CC} = 1.425\text{ V}$, Worst-Case $V_{CCI} = 1.7\text{ V}$
 Software Default Load at 10 pF for A3PN020, A3PN015, A3PN010

Drive Strength	Speed Grade	t_{DOUT}	t_{DP}	t_{DIN}	t_{PY}	t_{PYS}	t_{EOUT}	t_{ZL}	t_{ZH}	t_{LZ}	t_{HZ}	Units
2 mA	Std.	0.60	4.99	0.04	1.31	1.89	0.43	3.70	3.53	2.35	1.78	ns
	-1	0.51	4.24	0.04	1.12	1.60	0.36	3.15	3.01	2.00	1.51	ns
	-2	0.45	3.72	0.03	0.98	1.41	0.32	2.77	2.64	1.75	1.33	ns
4 mA	Std.	0.60	3.49	0.04	1.31	1.89	0.43	3.04	2.70	2.74	2.84	ns
	-1	0.51	2.97	0.04	1.12	1.60	0.36	2.58	2.30	2.33	2.42	ns
	-2	0.45	2.61	0.03	0.98	1.41	0.32	2.27	2.02	2.05	2.12	ns

Notes:

1. Software default selection highlighted in gray.
2. For specific junction temperature and voltage supply levels, refer to Table 2-6 on page 2-5 for derating values.

1.5 V LVCMOS (JESD8-11)

Low-Voltage CMOS for 1.5 V is an extension of the LVCMOS standard (JESD8-5) used for general-purpose 1.5 V applications. It uses a 1.5 V input buffer and a push-pull output buffer.

Table 2-46 • Minimum and Maximum DC Input and Output Levels

1.5 V LVCMOS	V_{IL}		V_{IH}		V_{OL}	V_{OH}	I_{OL}	I_{OH}	I_{OSL}	I_{OSH}	I_{IL}	I_{IH}
	Min., V	Max., V	Min., V	Max., V	Max., V	Min., V	m A	m A	Max., mA ³	Max., mA ³	μA_4	μA_4
2 mA	-0.3	0.35 * V_{CCI}	0.65 * V_{CCI}	3.6	0.25 * V_{CCI}	0.75 * V_{CCI}	2	2	13	16	10	10

Notes:

1. I_{IL} is the input leakage current per I/O pin over recommended operation conditions where $-0.3 V < V_{IN} < V_{IL}$.
2. I_{IH} is the input leakage current per I/O pin over recommended operating conditions $V_{IH} < V_{IN} < V_{CCI}$. Input current is larger when operating outside recommended ranges.
3. Currents are measured at high temperature (100°C junction temperature) and maximum voltage.
4. Currents are measured at 85°C junction temperature.
5. Software default selection highlighted in gray.

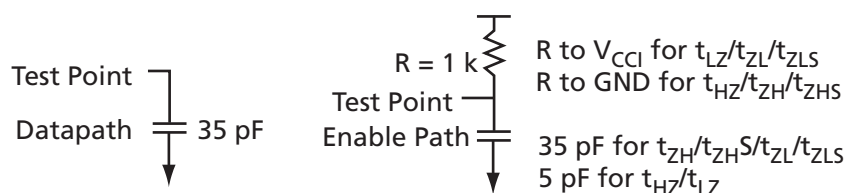

Figure 2-9 • AC Loading

Table 2-47 • 1.5 V LVCMOS AC Waveforms, Measuring Points, and Capacitive Loads

Input LOW (V)	Input HIGH (V)	Measuring Point* (V)	C_{LOAD} (pF)
0	1.5	0.75	10

Notes:

1. Measuring point = V_{trip} . See Table 2-16 on page 2-16 for a complete table of trip points.
2. Capacitive Load for A3PN060, A3PN125, and A3PN250 is 35 pF.

Timing Characteristics

Table 2-48 • 1.5 V LVCMOS Low Slew

Commercial-Case Conditions: $T_J = 70^\circ\text{C}$, Worst-Case $V_{CC} = 1.425\text{ V}$, Worst-Case $V_{CCI} = 1.4\text{ V}$
 Software Default Load at 35 pF for A3PN060, A3PN125, A3PN250

Drive Strength	Speed Grade	t_{DOUT}	t_{DP}	t_{DIN}	t_{PY}	t_{PYS}	t_{EOUT}	t_{ZL}	t_{ZH}	t_{LZ}	t_{HZ}	Units
2 mA	Std.	0.60	13.17	0.04	1.52	TBD	0.43	11.64	10.91	2.81	2.67	ns
	-1	0.51	11.20	0.04	1.29	TBD	0.36	9.90	9.28	2.39	2.27	ns
	-2	0.45	9.83	0.03	1.14	TBD	0.32	8.69	8.15	2.10	1.99	ns

Note: For specific junction temperature and voltage supply levels, refer to Table 2-6 on page 2-5 for derating values.

Table 2-49 • 1.5 V LVCMOS High Slew

Commercial-Case Conditions: $T_J = 70^\circ\text{C}$, Worst-Case $V_{CC} = 1.425\text{ V}$, Worst-Case $V_{CCI} = 1.4\text{ V}$
 Software Default Load at 35 pF for A3PN060, A3PN125, A3PN250

Drive Strength	Speed Grade	t_{DOUT}	t_{DP}	t_{DIN}	t_{PY}	t_{PYS}	t_{EOUT}	t_{ZL}	t_{ZH}	t_{LZ}	t_{HZ}	Units
2 mA	Std.	0.60	8.10	0.04	1.52	TBD	0.43	5.78	6.45	2.80	2.79	ns
	-1	0.51	6.89	0.04	1.29	TBD	0.36	4.92	5.48	2.39	2.37	ns
	-2	0.45	6.05	0.03	1.14	TBD	0.32	4.32	4.81	2.09	2.08	ns

Notes:

1. Software default selection highlighted in gray.
2. For specific junction temperature and voltage supply levels, refer to Table 2-6 on page 2-5 for derating values.

Table 2-50 • 1.5 V LVCMOS Low Slew

Commercial-Case Conditions: $T_J = 70^\circ\text{C}$, Worst-Case $V_{CC} = 1.425\text{ V}$, Worst-Case $V_{CCI} = 1.4\text{ V}$
 Software Default Load at 10 pF for A3PN020, A3PN015, A3PN010

Drive Strength	Speed Grade	t_{DOUT}	t_{DP}	t_{DIN}	t_{PY}	t_{PYS}	t_{EOUT}	t_{ZL}	t_{ZH}	t_{LZ}	t_{HZ}	Units
2 mA	Std.	0.60	8.87	0.04	1.52	2.14	0.43	8.06	7.19	2.81	2.67	ns
	-1	0.51	7.54	0.04	1.29	1.82	0.36	6.86	6.12	2.39	2.27	ns
	-2	0.45	6.62	0.03	1.14	1.60	0.32	6.02	5.37	2.10	1.99	ns

Note: For specific junction temperature and voltage supply levels, refer to Table 2-6 on page 2-5 for derating values.

Table 2-51 • 1.5 V LVCMOS High Slew

Commercial-Case Conditions: $T_J = 70^\circ\text{C}$, Worst-Case $V_{CC} = 1.425\text{ V}$, Worst-Case $V_{CCI} = 1.4\text{ V}$
 Software Default Load at 10 pF for A3PN020, A3PN015, A3PN010

Drive Strength	Speed Grade	t_{DOUT}	t_{DP}	t_{DIN}	t_{PY}	t_{PYS}	t_{EOUT}	t_{ZL}	t_{ZH}	t_{LZ}	t_{HZ}	Units
2 mA	Std.	0.60	4.04	0.04	1.52	2.14	0.43	3.50	3.11	2.80	2.79	ns
	-1	0.51	3.44	0.04	1.29	1.82	0.36	2.98	2.65	2.39	2.37	ns
	-2	0.45	3.02	0.03	1.14	1.60	0.32	2.62	2.32	2.09	2.08	ns

Notes:

1. Software default selection highlighted in gray.
2. For specific junction temperature and voltage supply levels, refer to Table 2-6 on page 2-5 for derating values.

I/O Register Specifications

Fully Registered I/O Buffers with Synchronous Enable and Asynchronous Preset

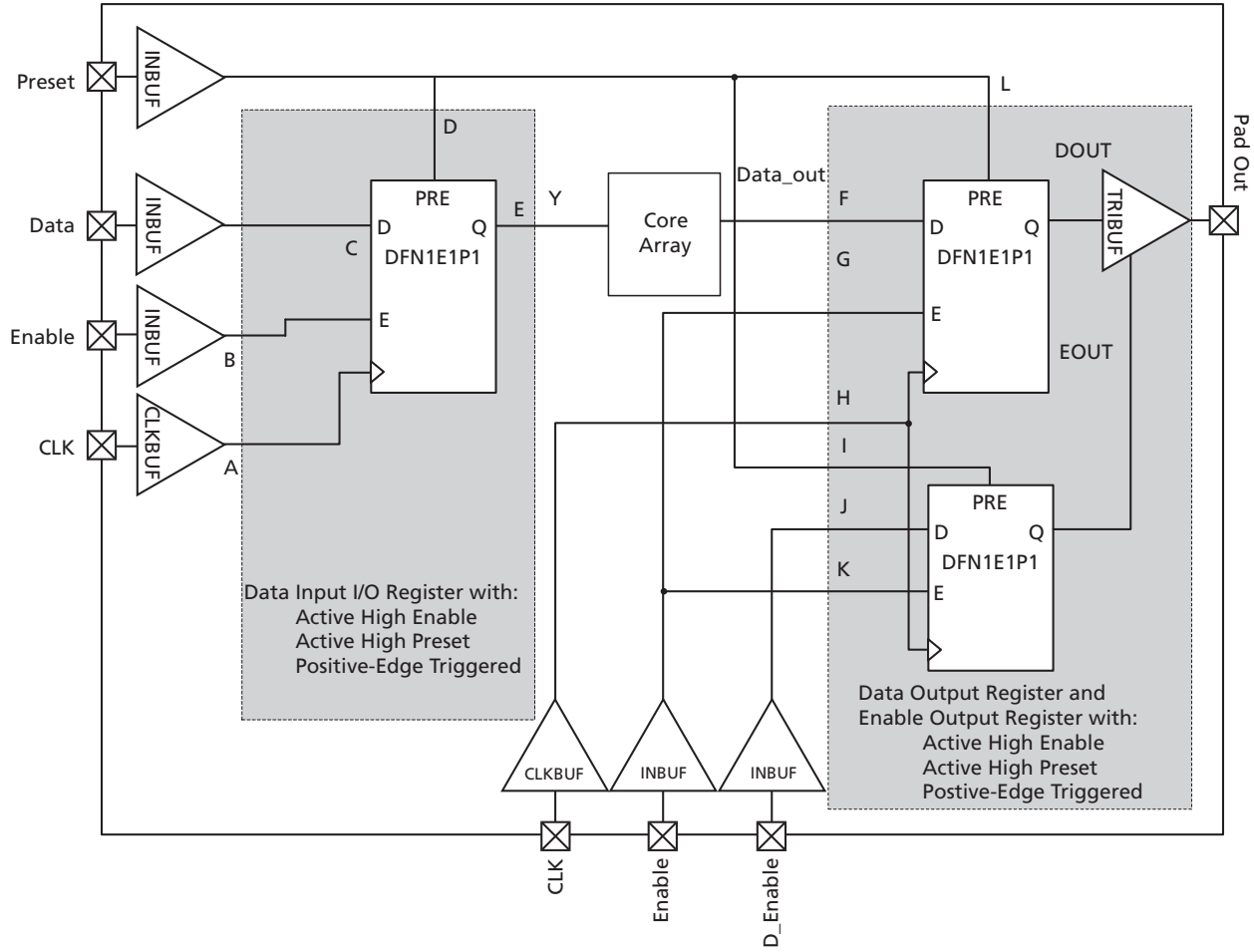

Figure 2-10 • Timing Model of Registered I/O Buffers with Synchronous Enable and Asynchronous Preset

Table 2-52 • Parameter Definition and Measuring Nodes

Parameter Name	Parameter Definition	Measuring Nodes (from, to)*
t _{OCLKQ}	Clock-to-Q of the Output Data Register	H, DOUT
t _{OSUD}	Data Setup Time for the Output Data Register	F, H
t _{OHD}	Data Hold Time for the Output Data Register	F, H
t _{OSUE}	Enable Setup Time for the Output Data Register	G, H
t _{OHE}	Enable Hold Time for the Output Data Register	G, H
t _{OPRE2Q}	Asynchronous Preset-to-Q of the Output Data Register	L, DOUT
t _{OEMPRE}	Asynchronous Preset Removal Time for the Output Data Register	L, H
t _{ORECPRE}	Asynchronous Preset Recovery Time for the Output Data Register	L, H
t _{OCLKQ}	Clock-to-Q of the Output Enable Register	H, EOUT
t _{OESUD}	Data Setup Time for the Output Enable Register	J, H
t _{OEH}	Data Hold Time for the Output Enable Register	J, H
t _{OESUE}	Enable Setup Time for the Output Enable Register	K, H
t _{OEH}	Enable Hold Time for the Output Enable Register	K, H
t _{OEPRE2Q}	Asynchronous Preset-to-Q of the Output Enable Register	I, EOUT
t _{OEMPRE}	Asynchronous Preset Removal Time for the Output Enable Register	I, H
t _{OERCPRE}	Asynchronous Preset Recovery Time for the Output Enable Register	I, H
t _{ICLKQ}	Clock-to-Q of the Input Data Register	A, E
t _{ISUD}	Data Setup Time for the Input Data Register	C, A
t _{IHD}	Data Hold Time for the Input Data Register	C, A
t _{ISUE}	Enable Setup Time for the Input Data Register	B, A
t _{IHE}	Enable Hold Time for the Input Data Register	B, A
t _{IPRE2Q}	Asynchronous Preset-to-Q of the Input Data Register	D, E
t _{IEMPRE}	Asynchronous Preset Removal Time for the Input Data Register	D, A
t _{IRECPRE}	Asynchronous Preset Recovery Time for the Input Data Register	D, A

* See Figure 2-10 on page 2-32 for more information.

Fully Registered I/O Buffers with Synchronous Enable and Asynchronous Clear

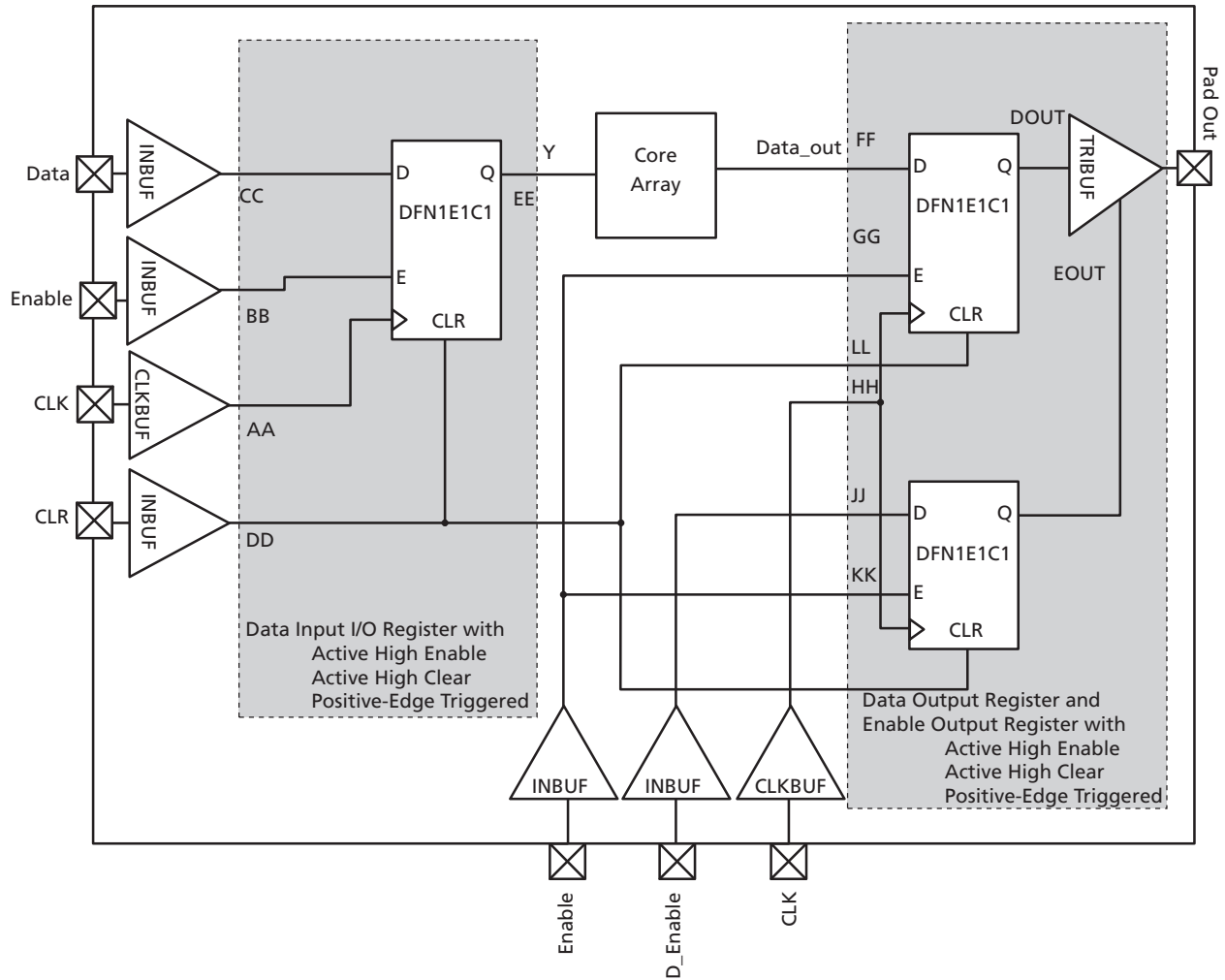

Figure 2-11 • Timing Model of the Registered I/O Buffers with Synchronous Enable and Asynchronous Clear

Table 2-53 • Parameter Definition and Measuring Nodes

Parameter Name	Parameter Definition	Measuring Nodes (from, to)*
t _{OCLKQ}	Clock-to-Q of the Output Data Register	HH, DOUT
t _{OSUD}	Data Setup Time for the Output Data Register	FF, HH
t _{OHD}	Data Hold Time for the Output Data Register	FF, HH
t _{OSUE}	Enable Setup Time for the Output Data Register	GG, HH
t _{OHE}	Enable Hold Time for the Output Data Register	GG, HH
t _{OCLR2Q}	Asynchronous Clear-to-Q of the Output Data Register	LL, DOUT
t _{OREMCLR}	Asynchronous Clear Removal Time for the Output Data Register	LL, HH
t _{ORECCLR}	Asynchronous Clear Recovery Time for the Output Data Register	LL, HH
t _{OECLKQ}	Clock-to-Q of the Output Enable Register	HH, EOUT
t _{OESUD}	Data Setup Time for the Output Enable Register	JJ, HH
t _{OEHd}	Data Hold Time for the Output Enable Register	JJ, HH
t _{OESUE}	Enable Setup Time for the Output Enable Register	KK, HH
t _{OEHdE}	Enable Hold Time for the Output Enable Register	KK, HH
t _{OECLR2Q}	Asynchronous Clear-to-Q of the Output Enable Register	II, EOUT
t _{OEREMCLR}	Asynchronous Clear Removal Time for the Output Enable Register	II, HH
t _{OERECCLR}	Asynchronous Clear Recovery Time for the Output Enable Register	II, HH
t _{ICLKQ}	Clock-to-Q of the Input Data Register	AA, EE
t _{ISUD}	Data Setup Time for the Input Data Register	CC, AA
t _{IHD}	Data Hold Time for the Input Data Register	CC, AA
t _{ISUE}	Enable Setup Time for the Input Data Register	BB, AA
t _{IHE}	Enable Hold Time for the Input Data Register	BB, AA
t _{ICLR2Q}	Asynchronous Clear-to-Q of the Input Data Register	DD, EE
t _{IREMCLR}	Asynchronous Clear Removal Time for the Input Data Register	DD, AA
t _{IRECCLR}	Asynchronous Clear Recovery Time for the Input Data Register	DD, AA

* See Figure 2-11 on page 2-34 for more information.

Input Register

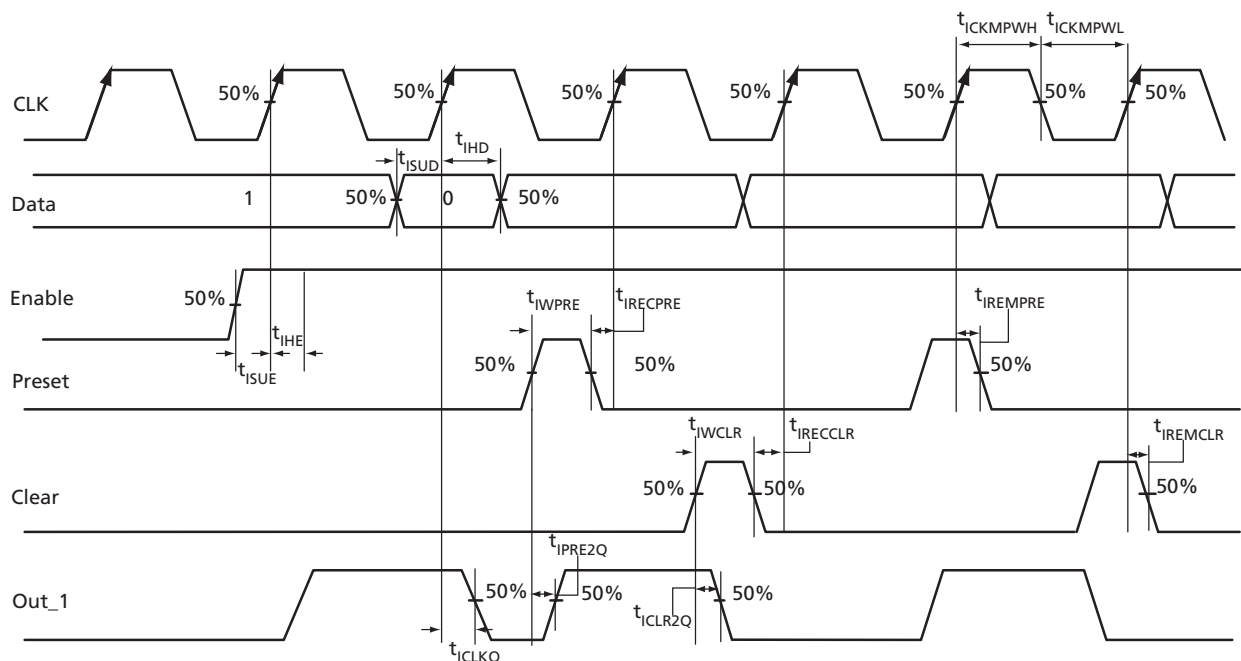

Figure 2-12 • Input Register Timing Diagram

Timing Characteristics

Table 2-54 • Input Data Register Propagation Delays

Commercial-Case Conditions: $T_J = 70^\circ\text{C}$, Worst-Case $V_{CC} = 1.425\text{ V}$

Parameter	Description	-2	-1	Std.	Units
t_{ICLKQ}	Clock-to-Q of the Input Data Register	0.24	0.27	0.32	ns
t_{ISUD}	Data Setup Time for the Input Data Register	0.26	0.30	0.35	ns
t_{IHD}	Data Hold Time for the Input Data Register	0.00	0.00	0.00	ns
t_{ICLR2Q}	Asynchronous Clear-to-Q of the Input Data Register	0.45	0.52	0.61	ns
t_{IPRE2Q}	Asynchronous Preset-to-Q of the Input Data Register	0.45	0.52	0.61	ns
$t_{IREMCLR}$	Asynchronous Clear Removal Time for the Input Data Register	0.00	0.00	0.00	ns
$t_{IRECCLR}$	Asynchronous Clear Recovery Time for the Input Data Register	0.22	0.25	0.30	ns
$t_{IREMPRE}$	Asynchronous Preset Removal Time for the Input Data Register	0.00	0.00	0.00	ns
$t_{IRECPRE}$	Asynchronous Preset Recovery Time for the Input Data Register	0.22	0.25	0.30	ns
t_{IWCLR}	Asynchronous Clear Minimum Pulse Width for the Input Data Register	0.22	0.25	0.30	ns
t_{IWPRE}	Asynchronous Preset Minimum Pulse Width for the Input Data Register	0.22	0.25	0.30	ns
$t_{ICKMPWH}$	Clock Minimum Pulse Width HIGH for the Input Data Register	0.36	0.41	0.48	ns
$t_{ICKMPWL}$	Clock Minimum Pulse Width LOW for the Input Data Register	0.32	0.37	0.43	ns

Note: For specific junction temperature and voltage supply levels, refer to Table 2-6 on page 2-5 for derating values.

Output Register

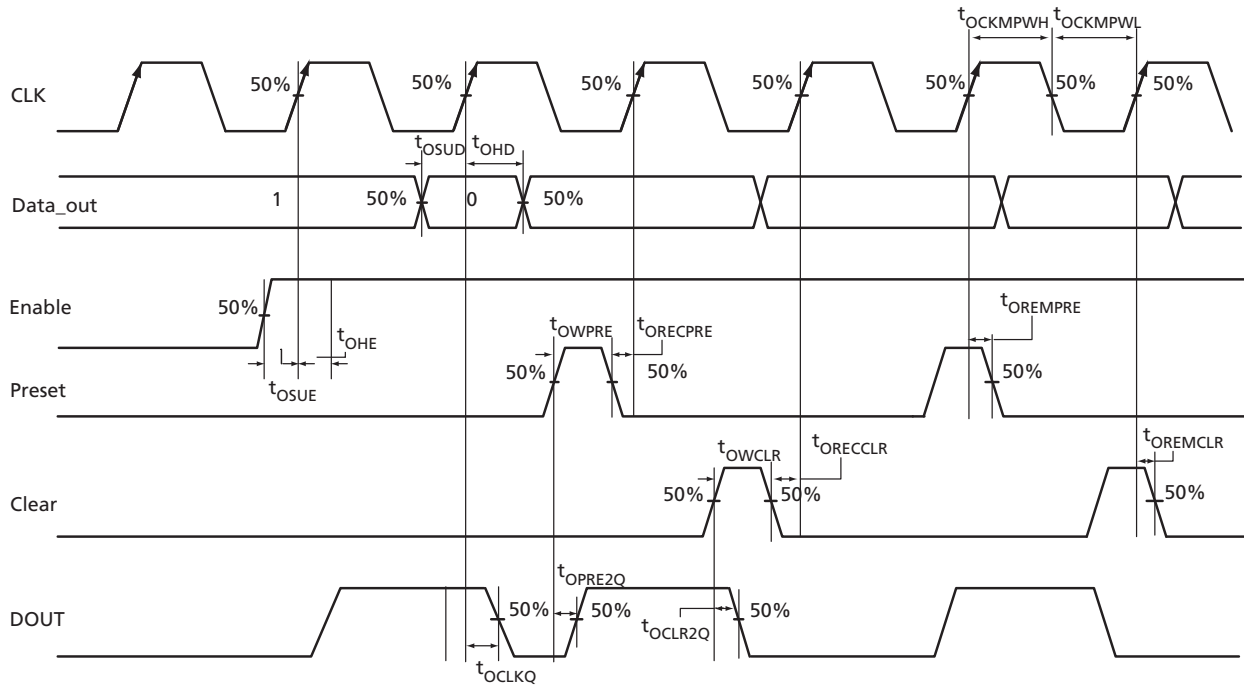

Figure 2-13 • Output Register Timing Diagram

Timing Characteristics

Table 2-55 • Output Data Register Propagation Delays
Commercial-Case Conditions: $T_J = 70^\circ\text{C}$, Worst-Case $V_{CC} = 1.425\text{ V}$

Parameter	Description	-2	-1	Std.	Units
t_{OCLKQ}	Clock-to-Q of the Output Data Register	0.59	0.67	0.79	ns
t_{OSUD}	Data Setup Time for the Output Data Register	0.31	0.36	0.42	ns
t_{OHD}	Data Hold Time for the Output Data Register	0.00	0.00	0.00	ns
t_{OCLR2Q}	Asynchronous Clear-to-Q of the Output Data Register	0.80	0.91	1.07	ns
t_{OPRE2Q}	Asynchronous Preset-to-Q of the Output Data Register	0.80	0.91	1.07	ns
$t_{OREMCLR}$	Asynchronous Clear Removal Time for the Output Data Register	0.00	0.00	0.00	ns
$t_{ORECCLR}$	Asynchronous Clear Recovery Time for the Output Data Register	0.22	0.25	0.30	ns
$t_{OREMPRE}$	Asynchronous Preset Removal Time for the Output Data Register	0.00	0.00	0.00	ns
$t_{ORECPRE}$	Asynchronous Preset Recovery Time for the Output Data Register	0.22	0.25	0.30	ns
t_{OWCLR}	Asynchronous Clear Minimum Pulse Width for the Output Data Register	0.22	0.25	0.30	ns
t_{OWPRE}	Asynchronous Preset Minimum Pulse Width for the Output Data Register	0.22	0.25	0.30	ns
$t_{OCLKMPWH}$	Clock Minimum Pulse Width HIGH for the Output Data Register	0.36	0.41	0.48	ns
$t_{OCLKMPWL}$	Clock Minimum Pulse Width LOW for the Output Data Register	0.32	0.37	0.43	ns

Note: For specific junction temperature and voltage supply levels, refer to Table 2-6 on page 2-5 for derating values.

Output Enable Register

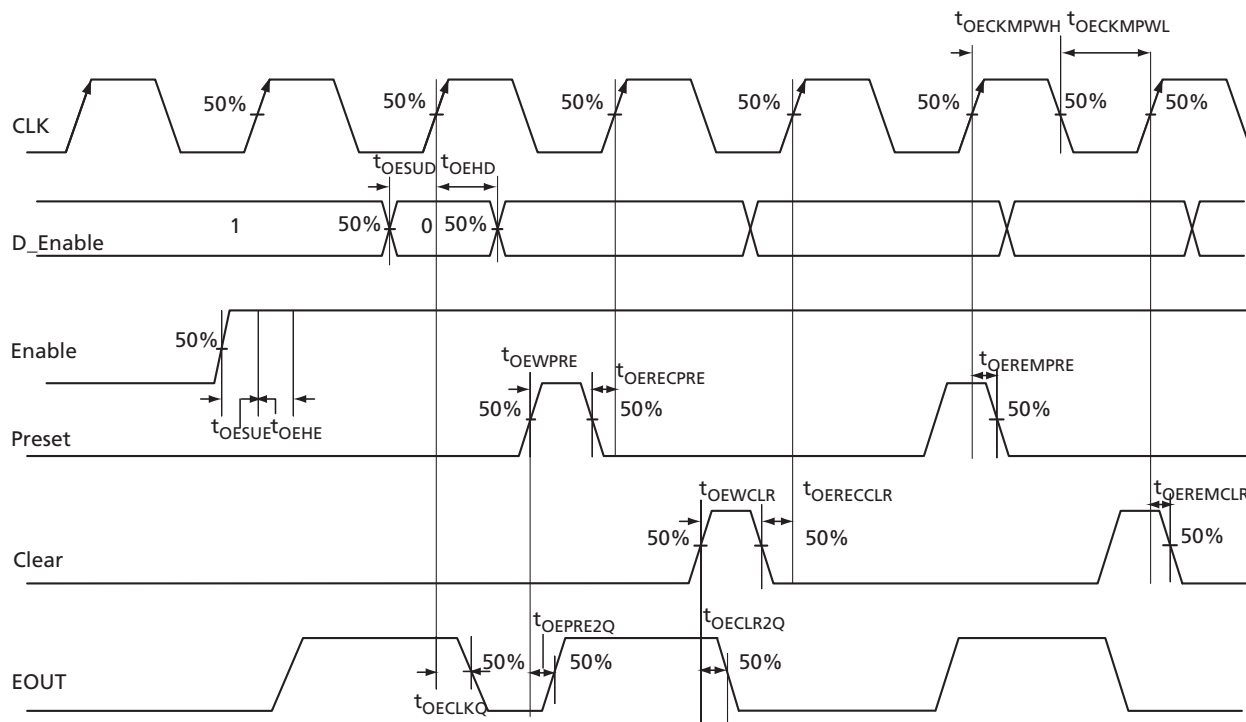

Figure 2-14 • Output Enable Register Timing Diagram

Timing Characteristics

Table 2-56 • Output Enable Register Propagation Delays
Commercial-Case Conditions: $T_J = 70^\circ\text{C}$, Worst-Case $V_{CC} = 1.425\text{ V}$

Parameter	Description	-2	-1	Std.	Units
t_{OECLKQ}	Clock-to-Q of the Output Enable Register	0.44	0.51	0.59	ns
t_{OESUD}	Data Setup Time for the Output Enable Register	0.31	0.36	0.42	ns
t_{OEHD}	Data Hold Time for the Output Enable Register	0.00	0.00	0.00	ns
$t_{OECLR2Q}$	Asynchronous Clear-to-Q of the Output Enable Register	0.67	0.76	0.89	ns
$t_{OEPRE2Q}$	Asynchronous Preset-to-Q of the Output Enable Register	0.67	0.76	0.89	ns
$t_{OEREMCLR}$	Asynchronous Clear Removal Time for the Output Enable Register	0.00	0.00	0.00	ns
$t_{OERECCLR}$	Asynchronous Clear Recovery Time for the Output Enable Register	0.22	0.25	0.30	ns
$t_{OEREMPRE}$	Asynchronous Preset Removal Time for the Output Enable Register	0.00	0.00	0.00	ns
$t_{OERECPRE}$	Asynchronous Preset Recovery Time for the Output Enable Register	0.22	0.25	0.30	ns
$t_{OEWCCLR}$	Asynchronous Clear Minimum Pulse Width for the Output Enable Register	0.22	0.25	0.30	ns
t_{OEWPRE}	Asynchronous Preset Minimum Pulse Width for the Output Enable Register	0.22	0.25	0.30	ns
$t_{OECKMPWH}$	Clock Minimum Pulse Width HIGH for the Output Enable Register	0.36	0.41	0.48	ns
$t_{OECKMPWL}$	Clock Minimum Pulse Width LOW for the Output Enable Register	0.32	0.37	0.43	ns

Note: For specific junction temperature and voltage supply levels, refer to Table 2-6 on page 2-5 for derating values.

DDR Module Specifications

Input DDR Module

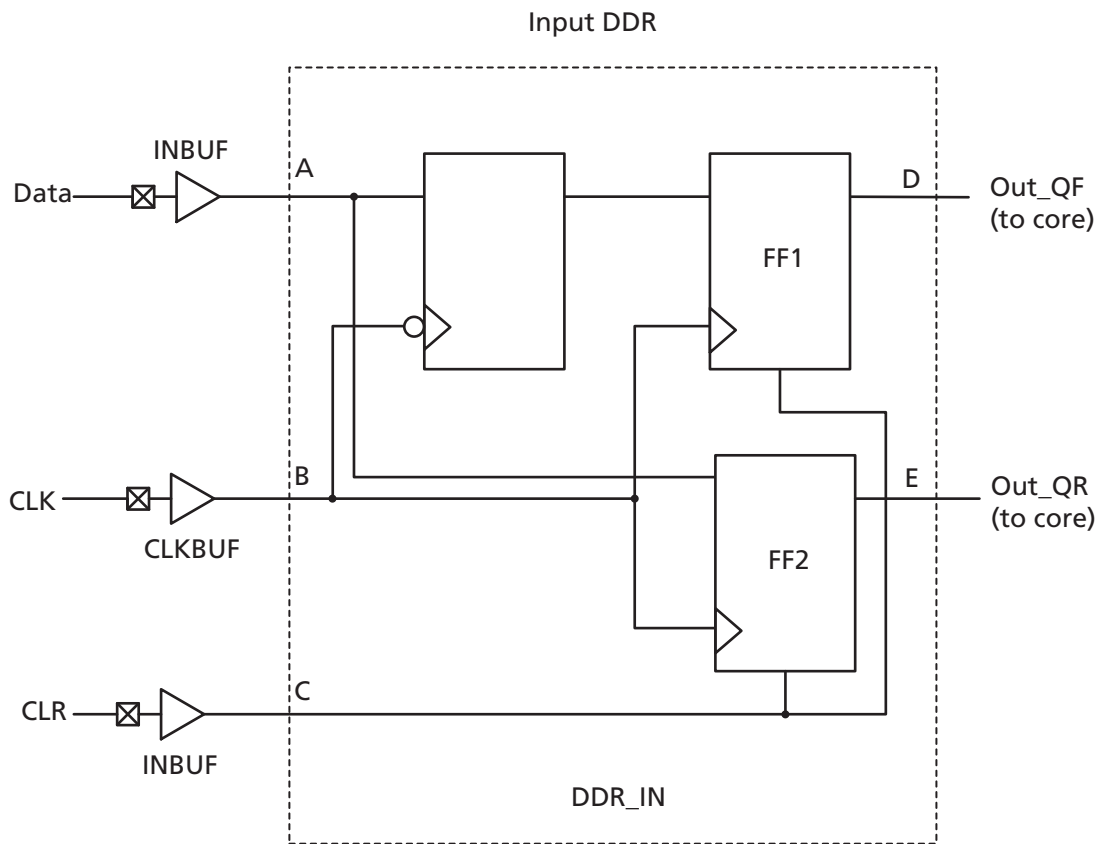
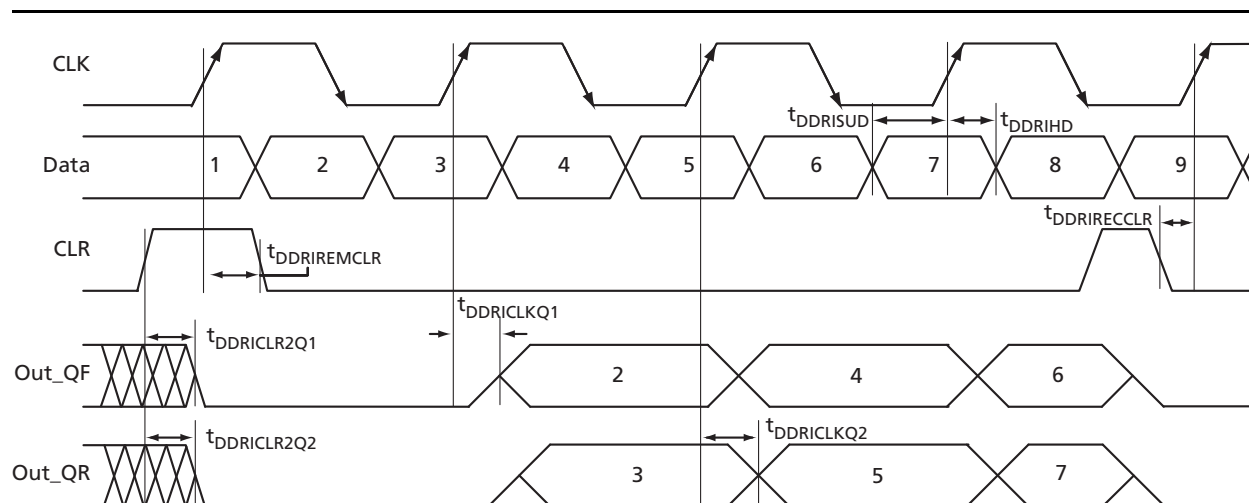

Figure 2-15 • Input DDR Timing Model

Table 2-57 • Parameter Definitions

Parameter Name	Parameter Definition	Measuring Nodes (from, to)
$t_{DDRICKQ1}$	Clock-to-Out Out_QR	B, D
$t_{DDRICKQ2}$	Clock-to-Out Out_QF	B, E
$t_{DDRISUD}$	Data Setup Time of DDR input	A, B
t_{DDRIHD}	Data Hold Time of DDR input	A, B
$t_{DDRICLR2Q1}$	Clear-to-Out Out_QR	C, D
$t_{DDRICLR2Q2}$	Clear-to-Out Out_QF	C, E
$t_{DDRIREMCLR}$	Clear Removal	C, B
$t_{DDRIRECCLR}$	Clear Recovery	C, B

Figure 2-16 • Input DDR Timing Diagram

Timing Characteristics

Table 2-58 • Input DDR Propagation Delays

 Commercial-Case Conditions: $T_J = 70^\circ\text{C}$, Worst Case $V_{CC} = 1.425\text{ V}$

Parameter	Description	-2	-1	Std.	Units
t_{DDRICKQ1}	Clock-to-Out Out_QR for Input DDR	0.27	0.31	0.37	ns
t_{DDRICKQ2}	Clock-to-Out Out_QF for Input DDR	0.39	0.44	0.52	ns
t_{DDRISUD}	Data Setup for Input DDR (Fall)	0.25	0.28	0.33	ns
	Data Setup for Input DDR (Rise)	0.25	0.28	0.33	ns
t_{DDRIHD}	Data Hold for Input DDR (Fall)	0.00	0.00	0.00	ns
	Data Hold for Input DDR (Rise)	0.00	0.00	0.00	ns
$t_{\text{DDRICLR2Q1}}$	Asynchronous Clear-to-Out Out_QR for Input DDR	0.46	0.53	0.62	ns
$t_{\text{DDRICLR2Q2}}$	Asynchronous Clear-to-Out Out_QF for Input DDR	0.57	0.65	0.76	ns
$t_{\text{DDRIREMCLR}}$	Asynchronous Clear Removal time for Input DDR	0.00	0.00	0.00	ns
$t_{\text{DDRIRECCLR}}$	Asynchronous Clear Recovery time for Input DDR	0.22	0.25	0.30	ns
t_{DDRIWCLR}	Asynchronous Clear Minimum Pulse Width for Input DDR	0.22	0.25	0.30	ns
$t_{\text{DDRICKMPWH}}$	Clock Minimum Pulse Width High for Input DDR	0.36	0.41	0.48	ns
$t_{\text{DDRICKMPWL}}$	Clock Minimum Pulse Width Low for Input DDR	0.32	0.37	0.43	ns
F_{DDRIMAX}	Maximum Frequency for Input DDR				MHz

Note: For specific junction temperature and voltage-supply levels, refer to [Table 2-6 on page 2-5](#) for derating values.

Output DDR Module

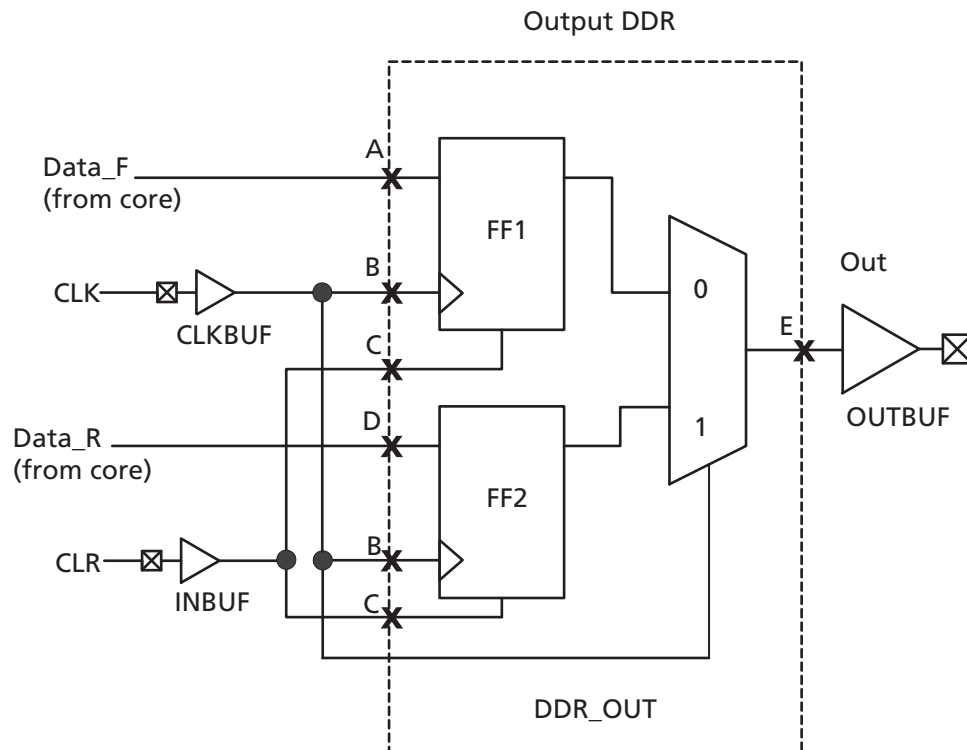
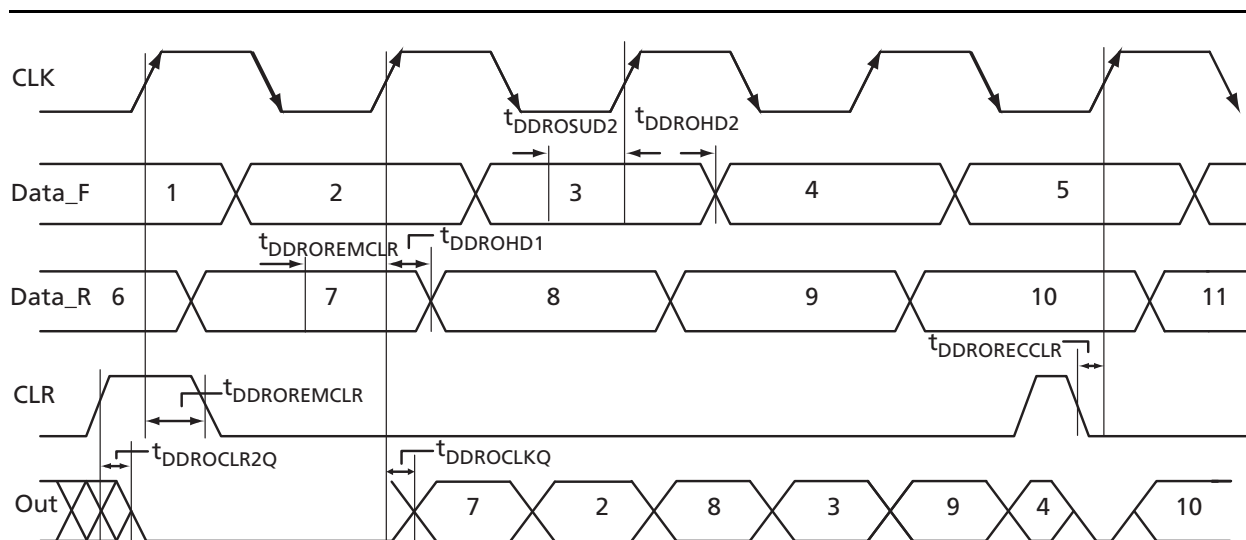

Figure 2-17 • Output DDR Timing Model

Table 2-59 • Parameter Definitions

Parameter Name	Parameter Definition	Measuring Nodes (from, to)
$t_{DDROCLKQ}$	Clock-to-Out	B, E
$t_{DDROCLR2Q}$	Asynchronous Clear-to-Out	C, E
$t_{DDROREMCLR}$	Clear Removal	C, B
$t_{DDRORECLR}$	Clear Recovery	C, B
$t_{DDROSUD1}$	Data Setup Data_F	A, B
$t_{DDROSUD2}$	Data Setup Data_R	D, B
$t_{DDROHD1}$	Data Hold Data_F	A, B
$t_{DDROHD2}$	Data Hold Data_R	D, B

Figure 2-18 • Output DDR Timing Diagram

Timing Characteristics

Table 2-60 • Output DDR Propagation Delays
 Commercial-Case Conditions: $T_j = 70^\circ\text{C}$, Worst-Case $V_{CC} = 1.425\text{ V}$

Parameter	Description	-2	-1	Std.	Units
t_{DDROCLKQ}	Clock-to-Out of DDR for Output DDR	0.70	0.80	0.94	ns
t_{DDROSUD1}	Data_F Data Setup for Output DDR	0.38	0.43	0.51	ns
t_{DDROSUD2}	Data_R Data Setup for Output DDR	0.38	0.43	0.51	ns
t_{DDROHD1}	Data_F Data Hold for Output DDR	0.00	0.00	0.00	ns
t_{DDROHD2}	Data_R Data Hold for Output DDR	0.00	0.00	0.00	ns
$t_{\text{DDROCLR2Q}}$	Asynchronous Clear-to-Out for Output DDR	0.80	0.91	1.07	ns
$t_{\text{DDROEMCLR}}$	Asynchronous Clear Removal Time for Output DDR	0.00	0.00	0.00	ns
$t_{\text{DDROECCLR}}$	Asynchronous Clear Recovery Time for Output DDR	0.22	0.25	0.30	ns
$t_{\text{DDROWCLR1}}$	Asynchronous Clear Minimum Pulse Width for Output DDR	0.22	0.25	0.30	ns
$t_{\text{DDROCKMPWH}}$	Clock Minimum Pulse Width HIGH for the Output DDR	0.36	0.41	0.48	ns
$t_{\text{DDROCKMPWL}}$	Clock Minimum Pulse Width LOW for the Output DDR	0.32	0.37	0.43	ns
f_{DDOMAX}	Maximum Frequency for the Output DDR	TBD	TBD	TBD	MHz

Note: For specific junction temperature and voltage supply levels, refer to [Table 2-6 on page 2-5](#) for derating values.

VersaTile Characteristics

VersaTile Specifications as a Combinatorial Module

The ProASIC3 library offers all combinations of LUT-3 combinatorial functions. In this section, timing characteristics are presented for a sample of the library. For more details, refer to the *Fusion, IGLOO[®]le, and ProASIC3/E Macro Library Guide*.

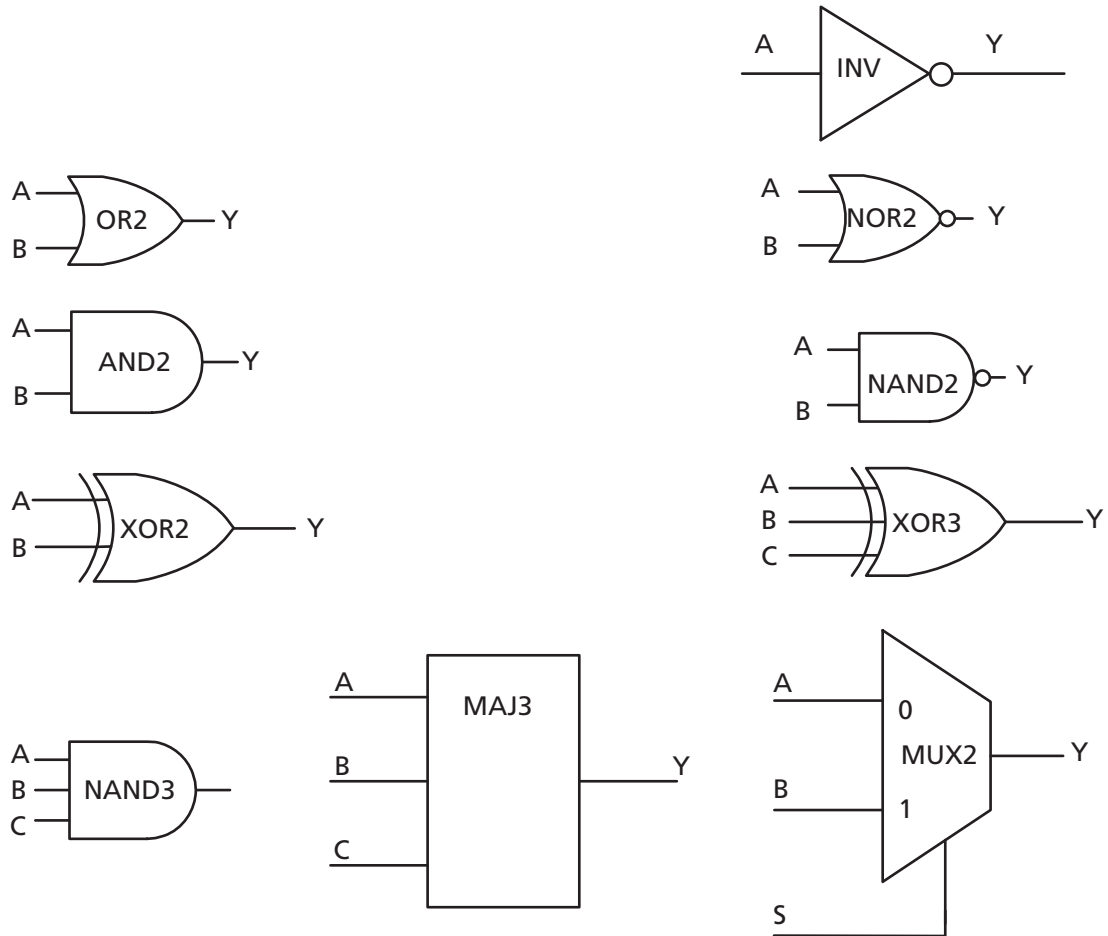

Figure 2-19 • Sample of Combinatorial Cells

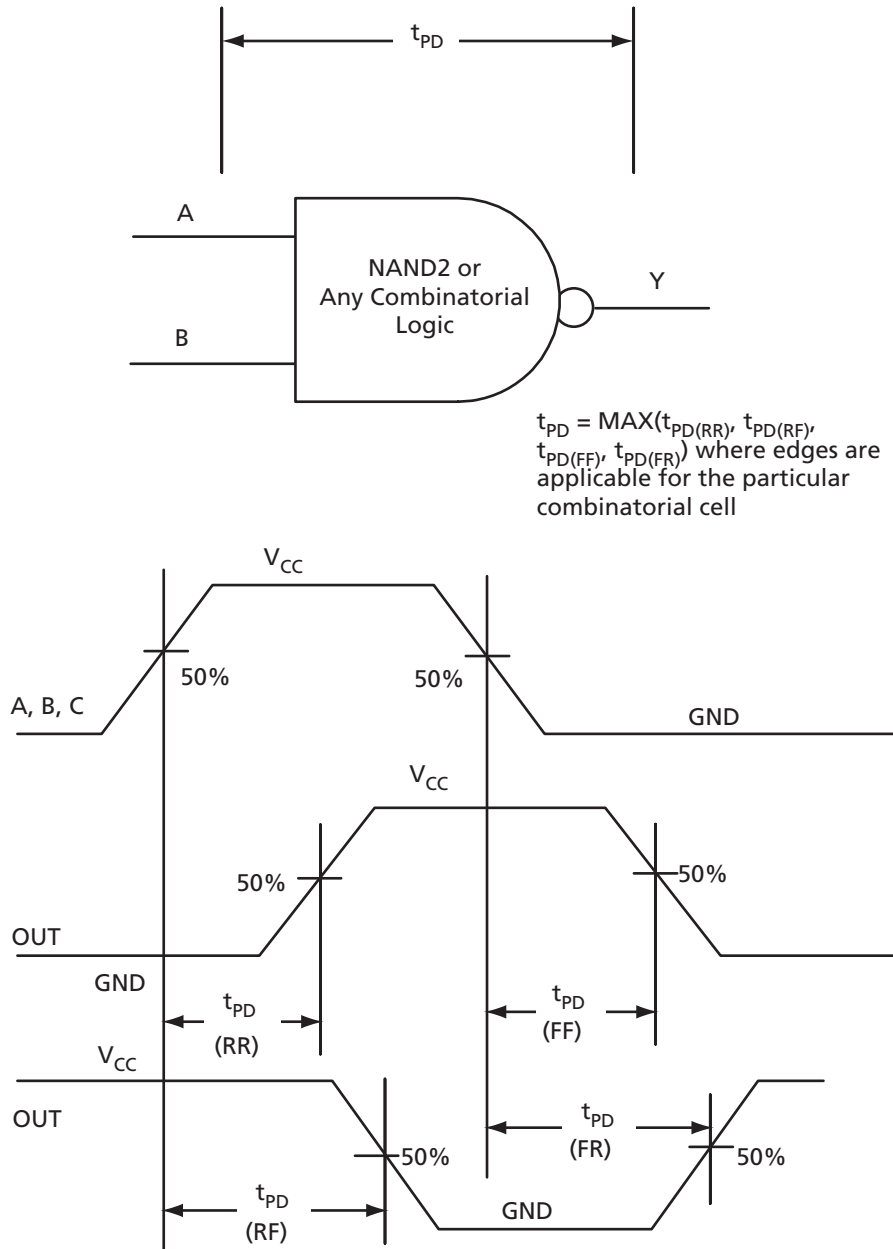

Figure 2-20 • Timing Model and Waveforms

Timing Characteristics

Table 2-61 • Combinatorial Cell Propagation Delays
 Commercial-Case Conditions: $T_j = 70^\circ\text{C}$, Worst-Case $V_{CC} = 1.425\text{ V}$

Combinatorial Cell	Equation	Parameter	-2	-1	Std.	Units
INV	$Y = !A$	t_{PD}	0.40	0.46	0.54	ns
AND2	$Y = A \cdot B$	t_{PD}	0.47	0.54	0.63	ns
NAND2	$Y = !(A \cdot B)$	t_{PD}	0.47	0.54	0.63	ns
OR2	$Y = A + B$	t_{PD}	0.49	0.55	0.65	ns
NOR2	$Y = !(A + B)$	t_{PD}	0.49	0.55	0.65	ns
XOR2	$Y = A \oplus B$	t_{PD}	0.74	0.84	0.99	ns
MAJ3	$Y = \text{MAJ}(A, B, C)$	t_{PD}	0.70	0.79	0.93	ns
XOR3	$Y = A \oplus B \oplus C$	t_{PD}	0.87	1.00	1.17	ns
MUX2	$Y = A !S + B S$	t_{PD}	0.51	0.58	0.68	ns
AND3	$Y = A \cdot B \cdot C$	t_{PD}	0.56	0.64	0.75	ns

Note: For specific junction temperature and voltage supply levels, refer to [Table 2-6 on page 2-5](#) for derating values.

VersaTile Specifications as a Sequential Module

The ProASIC3 library offers a wide variety of sequential cells, including flip-flops and latches. Each has a data input and optional enable, clear, or preset. In this section, timing characteristics are presented for a representative sample from the library. For more details, refer to the [Fusion](#), [IGLOOe](#), and [ProASIC3/E Macro Library Guide](#).

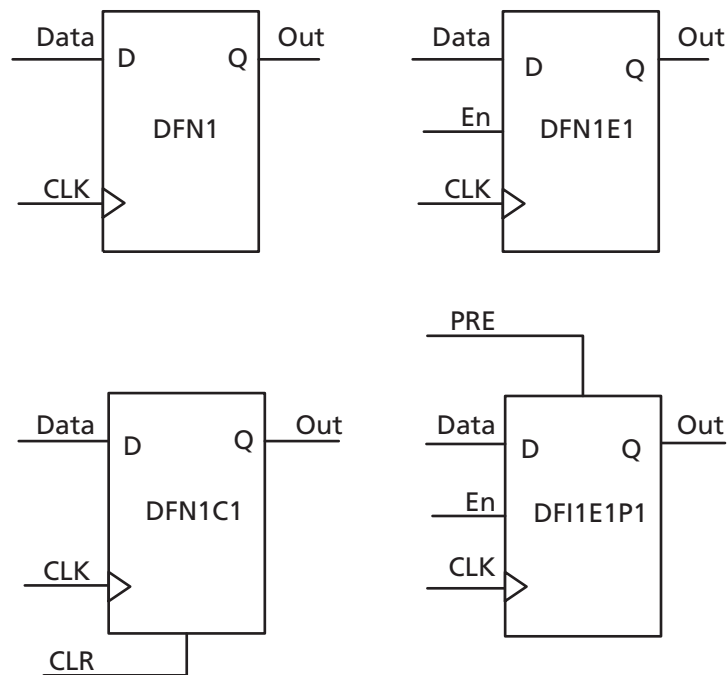
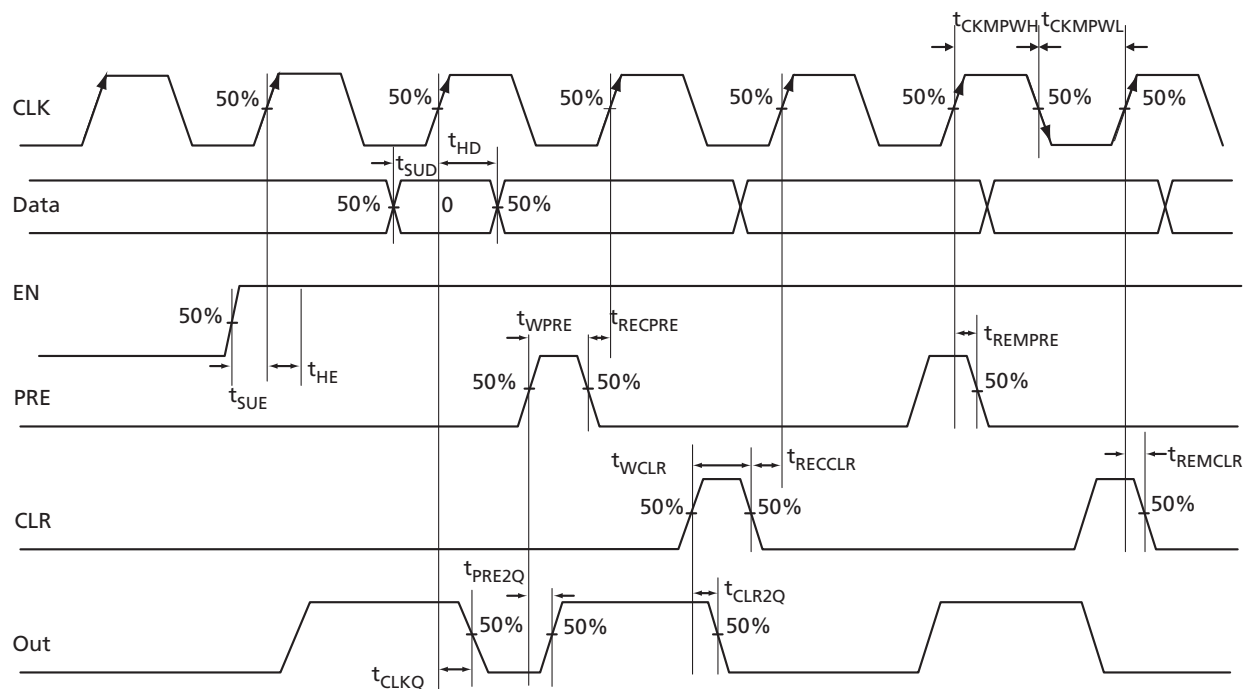

Figure 2-21 • Sample of Sequential Cells

Figure 2-22 • Timing Model and Waveforms

Timing Characteristics

Table 2-62 • Register Delays

 Commercial-Case Conditions: $T_J = 70^\circ\text{C}$, Worst-Case $V_{CC} = 1.425\text{ V}$

Parameter	Description	-2	-1	Std.	Units
t_{CLKQ}	Clock-to-Q of the Core Register	0.55	0.63	0.74	ns
t_{SUD}	Data Setup Time for the Core Register	0.43	0.49	0.57	ns
t_{HD}	Data Hold Time for the Core Register	0.00	0.00	0.00	ns
t_{SUE}	Enable Setup Time for the Core Register	0.45	0.52	0.61	ns
t_{HE}	Enable Hold Time for the Core Register	0.00	0.00	0.00	ns
t_{CLR2Q}	Asynchronous Clear-to-Q of the Core Register	0.40	0.45	0.53	ns
t_{PRE2Q}	Asynchronous Preset-to-Q of the Core Register	0.40	0.45	0.53	ns
t_{REMCLR}	Asynchronous Clear Removal Time for the Core Register	0.00	0.00	0.00	ns
t_{RECLL}	Asynchronous Clear Recovery Time for the Core Register	0.22	0.25	0.30	ns
t_{REMPRE}	Asynchronous Preset Removal Time for the Core Register	0.00	0.00	0.00	ns
t_{RECPRE}	Asynchronous Preset Recovery Time for the Core Register	0.22	0.25	0.30	ns
t_{WCLR}	Asynchronous Clear Minimum Pulse Width for the Core Register	0.22	0.25	0.30	ns
t_{WPRE}	Asynchronous Preset Minimum Pulse Width for the Core Register	0.22	0.25	0.30	ns
t_{CKMPWH}	Clock Minimum Pulse Width HIGH for the Core Register	0.36	0.41	0.48	ns
t_{CKMPWL}	Clock Minimum Pulse Width LOW for the Core Register	0.32	0.37	0.43	ns

Note: For specific junction temperature and voltage supply levels, refer to Table 2-6 on page 2-5 for derating values.

Global Resource Characteristics

A3PN250 Clock Tree Topology

Clock delays are device-specific. Figure 2-23 is an example of a global tree used for clock routing. The global tree presented in Figure 2-23 is driven by a CCC located on the west side of the A3PN250 device. It is used to drive all D-flip-flops in the device.

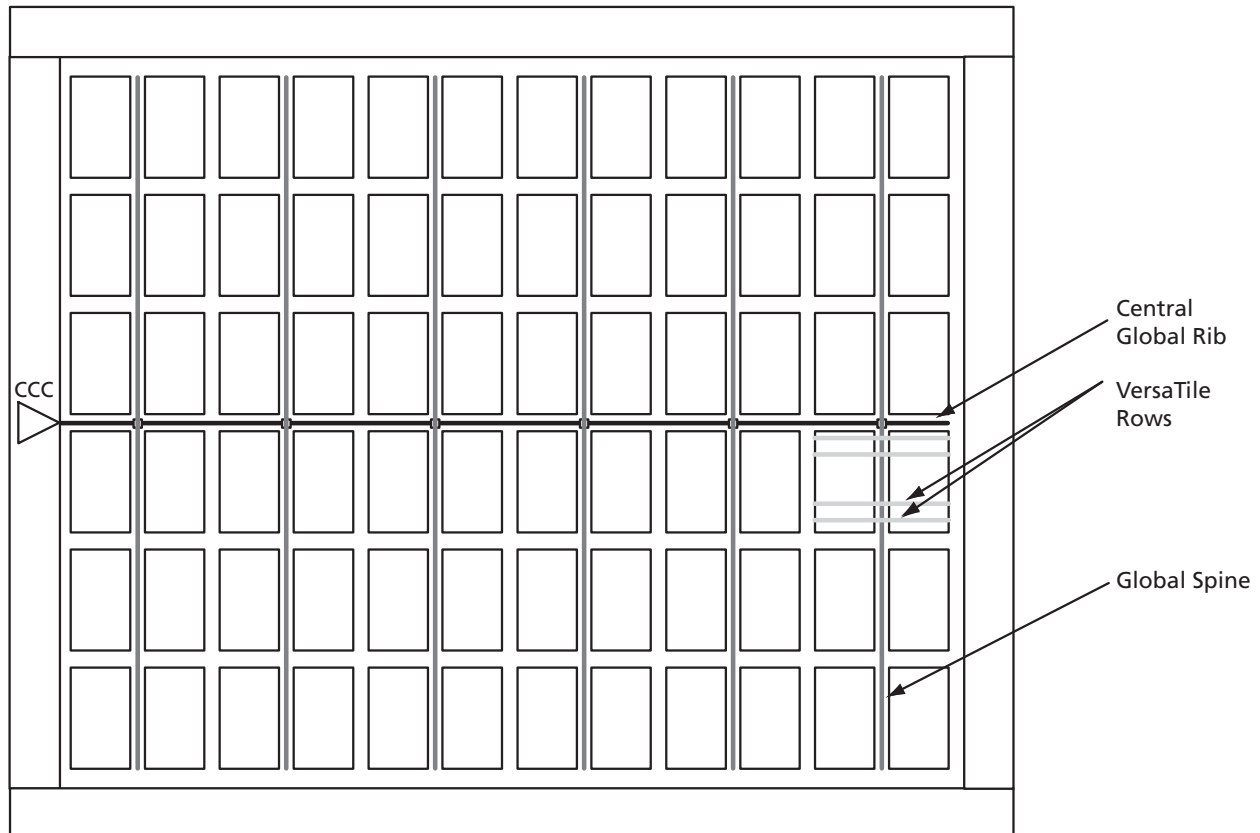

Figure 2-23 • Example of Global Tree Use in an A3PN250 Device for Clock Routing

Global Tree Timing Characteristics

Global clock delays include the central rib delay, the spine delay, and the row delay. Delays do not include I/O input buffer clock delays, as these are I/O standard-dependent, and the clock may be driven and conditioned internally by the CCC module. For more details on clock conditioning capabilities, refer to the "Clock Conditioning Circuits" section on page 2-51. Table 2-63 to Table 2-68 on page 2-50 present minimum and maximum global clock delays within each device. Minimum and maximum delays are measured with minimum and maximum loading.

Timing Characteristics

Table 2-63 • A3PN010 Global Resource
Commercial-Case Conditions: $T_J = 70^\circ\text{C}$, $V_{CC} = 1.425\text{ V}$

Parameter	Description	-2		-1		Std.		Units
		Min. ¹	Max. ²	Min. ¹	Max. ²	Min. ¹	Max. ²	
t_{RCKL}	Input LOW Delay for Global Clock	0.56	0.75	0.64	0.85	0.75	1.00	ns
t_{RCKH}	Input HIGH Delay for Global Clock	0.57	0.79	0.65	0.90	0.76	1.05	ns
$t_{RCKMPWH}$	Minimum Pulse Width HIGH for Global Clock							ns
$t_{RCKMPWL}$	Minimum Pulse Width LOW for Global Clock							ns
t_{RCKSW}	Maximum Skew for Global Clock		0.22		0.25		0.29	ns
F_{RMAX}	Maximum Frequency for Global Clock							MHz

Notes:

1. Value reflects minimum load. The delay is measured from the CCC output to the clock pin of a sequential element, located in a lightly loaded row (single element is connected to the global net).
2. Value reflects maximum load. The delay is measured on the clock pin of the farthest sequential element, located in a fully loaded row (all available flip-flops are connected to the global net in the row).
3. For specific junction temperature and voltage-supply levels, refer to Table 2-6 on page 2-5 for derating values.

Table 2-64 • A3PN015 Global Resource
Commercial-Case Conditions: $T_J = 70^\circ\text{C}$, $V_{CC} = 1.425\text{ V}$

Parameter	Description	-2		-1		Std.		Units
		Min. ¹	Max. ²	Min. ¹	Max. ²	Min. ¹	Max. ²	
t_{RCKL}	Input LOW Delay for Global Clock	0.61	0.86	0.70	0.98	0.82	1.15	ns
t_{RCKH}	Input HIGH Delay for Global Clock	0.62	0.91	0.71	1.03	0.83	1.21	ns
$t_{RCKMPWH}$	Minimum Pulse Width HIGH for Global Clock							ns
$t_{RCKMPWL}$	Minimum Pulse Width LOW for Global Clock							ns
t_{RCKSW}	Maximum Skew for Global Clock		0.28		0.32		0.38	ns
F_{RMAX}	Maximum Frequency for Global Clock							MHz

Notes:

1. Value reflects minimum load. The delay is measured from the CCC output to the clock pin of a sequential element, located in a lightly loaded row (single element is connected to the global net).
2. Value reflects maximum load. The delay is measured on the clock pin of the farthest sequential element, located in a fully loaded row (all available flip-flops are connected to the global net in the row).
3. For specific junction temperature and voltage-supply levels, refer to Table 2-6 on page 2-5 for derating values.

Table 2-65 • A3PN020 Global Resource
 Commercial-Case Conditions: $T_J = 70^\circ\text{C}$, $V_{CC} = 1.425\text{ V}$

Parameter	Description	-2		-1		Std.		Units
		Min. ¹	Max. ²	Min. ¹	Max. ²	Min. ¹	Max. ²	
t_{RCKL}	Input LOW Delay for Global Clock	0.61	0.86	0.70	0.98	0.82	1.15	ns
t_{RCKH}	Input HIGH Delay for Global Clock	0.62	0.91	0.71	1.03	0.83	1.21	ns
$t_{RCKMPWH}$	Minimum Pulse Width HIGH for Global Clock							ns
$t_{RCKMPWL}$	Minimum Pulse Width LOW for Global Clock							ns
t_{RCKSW}	Maximum Skew for Global Clock		0.28		0.32		0.38	ns
F_{RMAX}	Maximum Frequency for Global Clock							MHz

Notes:

1. Value reflects minimum load. The delay is measured from the CCC output to the clock pin of a sequential element, located in a lightly loaded row (single element is connected to the global net).
2. Value reflects maximum load. The delay is measured on the clock pin of the farthest sequential element, located in a fully loaded row (all available flip-flops are connected to the global net in the row).
3. For specific junction temperature and voltage-supply levels, refer to [Table 2-6 on page 2-5](#) for derating values.

Table 2-66 • A3PN060 Global Resource
 Commercial-Case Conditions: $T_J = 70^\circ\text{C}$, $V_{CC} = 1.425\text{ V}$

Parameter	Description	-2		-1		Std.		Units
		Min. ¹	Max. ²	Min. ¹	Max. ²	Min. ¹	Max. ²	
t_{RCKL}	Input LOW Delay for Global Clock	0.72	0.95	0.82	1.08	0.96	1.26	ns
t_{RCKH}	Input HIGH Delay for Global Clock	0.71	0.96	0.81	1.11	0.96	1.30	ns
$t_{RCKMPWH}$	Minimum Pulse Width HIGH for Global Clock							ns
$t_{RCKMPWL}$	Minimum Pulse Width LOW for Global Clock							ns
t_{RCKSW}	Maximum Skew for Global Clock		0.25		0.30		0.35	ns
F_{RMAX}	Maximum Frequency for Global Clock							MHz

Notes:

1. Value reflects minimum load. The delay is measured from the CCC output to the clock pin of a sequential element, located in a lightly loaded row (single element is connected to the global net).
2. Value reflects maximum load. The delay is measured on the clock pin of the farthest sequential element, located in a fully loaded row (all available flip-flops are connected to the global net in the row).
3. For specific junction temperature and voltage-supply levels, refer to [Table 2-6 on page 2-5](#) for derating values.

Table 2-67 • A3PN125 Global Resource
 Commercial-Case Conditions: $T_J = 70^\circ\text{C}$, $V_{CC} = 1.425\text{ V}$

Parameter	Description	-2		-1		Std.		Units
		Min. ¹	Max. ²	Min. ¹	Max. ²	Min. ¹	Max. ²	
t_{RCKL}	Input LOW Delay for Global Clock	0.76	0.99	0.87	1.12	1.02	1.32	ns
t_{RCKH}	Input HIGH Delay for Global Clock	0.76	1.02	0.87	1.17	1.02	1.37	ns
$t_{RCKMPWH}$	Minimum Pulse Width HIGH for Global Clock							ns
$t_{RCKMPWL}$	Minimum Pulse Width LOW for Global Clock							ns
t_{RCKSW}	Maximum Skew for Global Clock		0.26		0.30		0.35	ns
F_{RMAX}	Maximum Frequency for Global Clock							MHz

Notes:

1. Value reflects minimum load. The delay is measured from the CCC output to the clock pin of a sequential element, located in a lightly loaded row (single element is connected to the global net).
2. Value reflects maximum load. The delay is measured on the clock pin of the farthest sequential element, located in a fully loaded row (all available flip-flops are connected to the global net in the row).
3. For specific junction temperature and voltage-supply levels, refer to [Table 2-6 on page 2-5](#) for derating values.

Table 2-68 • A3PN250 Global Resource
 Commercial-Case Conditions: $T_J = 70^\circ\text{C}$, $V_{CC} = 1.425\text{ V}$

Parameter	Description	-2		-1		Std.		Units
		Min. ¹	Max. ²	Min. ¹	Max. ²	Min. ¹	Max. ²	
t_{RCKL}	Input LOW Delay for Global Clock	0.79	1.02	0.90	1.16	1.06	1.36	ns
t_{RCKH}	Input HIGH Delay for Global Clock	0.78	1.04	0.88	1.18	1.04	1.39	ns
$t_{RCKMPWH}$	Minimum Pulse Width HIGH for Global Clock							ns
$t_{RCKMPWL}$	Minimum Pulse Width LOW for Global Clock							ns
t_{RCKSW}	Maximum Skew for Global Clock		0.26		0.30		0.35	ns
F_{RMAX}	Maximum Frequency for Global Clock							MHz

Notes:

1. Value reflects minimum load. The delay is measured from the CCC output to the clock pin of a sequential element, located in a lightly loaded row (single element is connected to the global net).
2. Value reflects maximum load. The delay is measured on the clock pin of the farthest sequential element, located in a fully loaded row (all available flip-flops are connected to the global net in the row).
3. For specific junction temperature and voltage-supply levels, refer to [Table 2-6 on page 2-5](#) for derating values.

Clock Conditioning Circuits

CCC Electrical Specifications

Timing Characteristics

Table 2-69 • ProASIC3 nano CCC/PLL Specification

Parameter	Minimum	Typical	Maximum	Units
Clock Conditioning Circuitry Input Frequency f_{IN_CCC}	1.5		350	MHz
Clock Conditioning Circuitry Output Frequency f_{OUT_CCC}	0.75		350	MHz
Delay Increments in Programmable Delay Blocks ^{1,2}		200		ps
Number of Programmable Values in Each Programmable Delay Block			32	
Serial Clock (SCLK) for Dynamic PLL ³			125	MHz
Input Cycle-to-Cycle Jitter (peak magnitude)			1.5	ns
CCC Output Peak-to-Peak Period Jitter F_{CCC_OUT}	Max Peak-to-Peak Period Jitter			
	1 Global Network Used	External FB Used	3 Global Networks Used	
0.75 MHz to 24 MHz	0.50%		0.70%	
24 MHz to 100 MHz	1.00%		1.20%	
100 MHz to 250 MHz	1.75%		2.00%	
250 MHz to 350 MHz	2.50%		5.60%	
Acquisition Time	LockControl = 0		300	μ s
	LockControl = 1		6.0	ms
Tracking Jitter ⁵	LockControl = 0		1.6	ns
	LockControl = 1		0.8	ns
Output Duty Cycle	48.5		51.5	%
Delay Range in Block: Programmable Delay 1 ^{1,2}	1.25		15.65	ns
Delay Range in Block: Programmable Delay 2 ^{1,2}	0.025		15.65	ns
Delay Range in Block: Fixed Delay ^{1,2}		2.2		ns

Notes:

1. This delay is a function of voltage and temperature. See [Table 2-6 on page 2-5](#) for deratings.
2. $T_J = 25^\circ\text{C}$, $V_{CC} = 1.5\text{ V}$
3. Maximum value obtained for a -2 speed-grade device in worst-case commercial conditions. For specific junction temperature and voltage supply levels, refer to [Table 2-6 on page 2-5](#) for derating values.
4. The A3PN010, A3PN015, and A3PN020 devices do not support PLLs.
5. Tracking jitter is defined as the variation in clock edge position of PLL outputs with reference to the PLL input clock edge. Tracking jitter does not measure the variation in PLL output period, which is covered by the period jitter parameter.

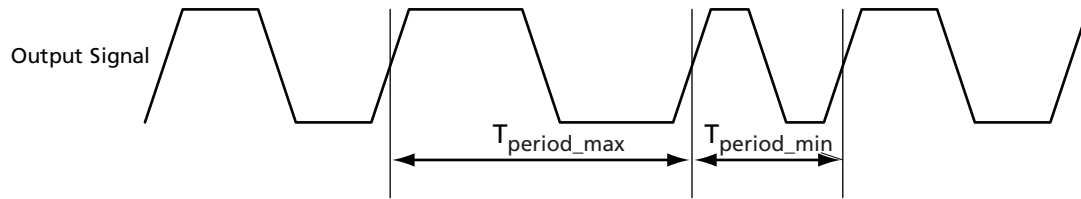

Note: Peak-to-peak jitter measurements are defined by $T_{\text{peak-to-peak}} = T_{\text{period_max}} - T_{\text{period_min}}$.

Figure 2-24 • Peak-to-Peak Jitter Definition

Embedded SRAM and FIFO Characteristics

SRAM

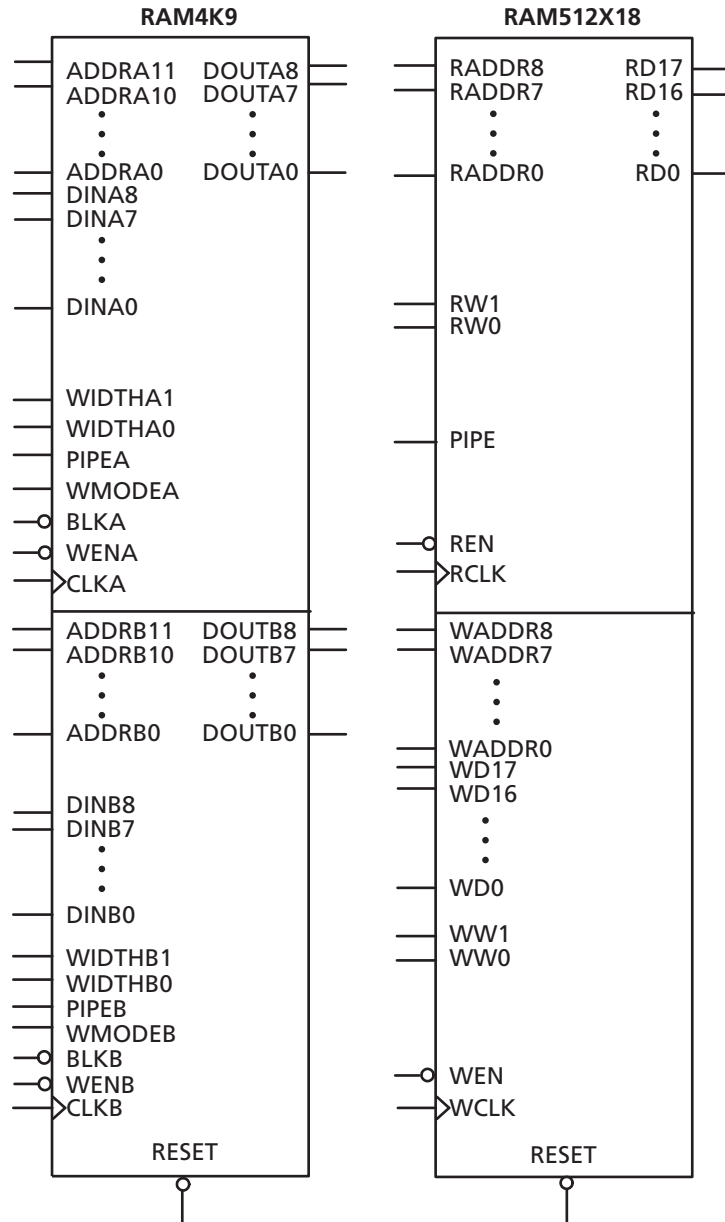

Figure 2-25 • RAM Models

Timing Waveforms

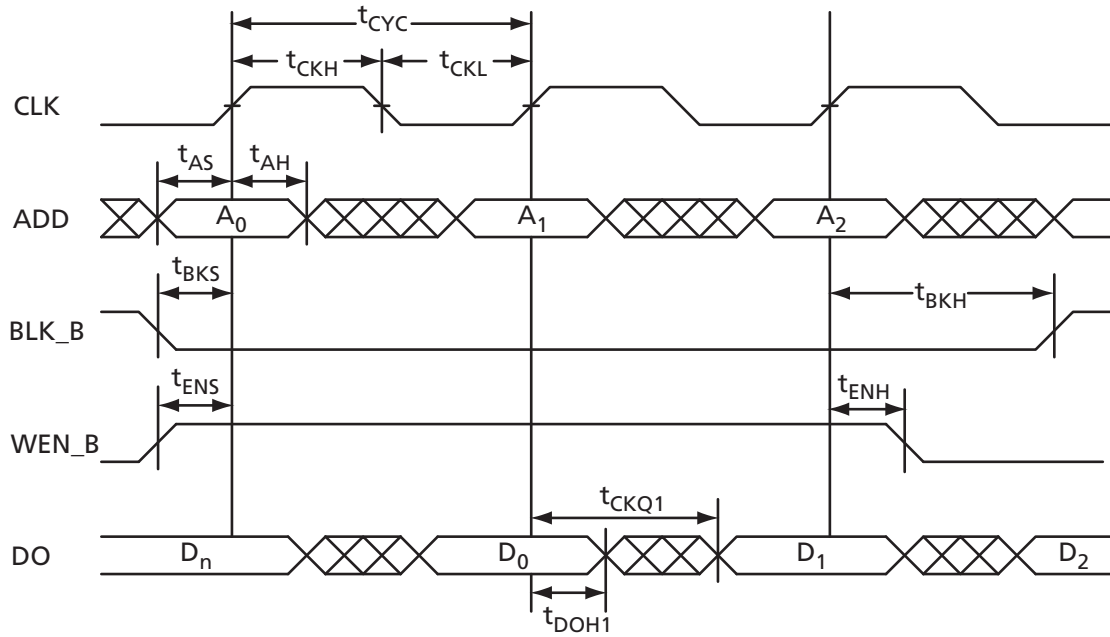

Figure 2-26 • RAM Read for Pass-Through Output

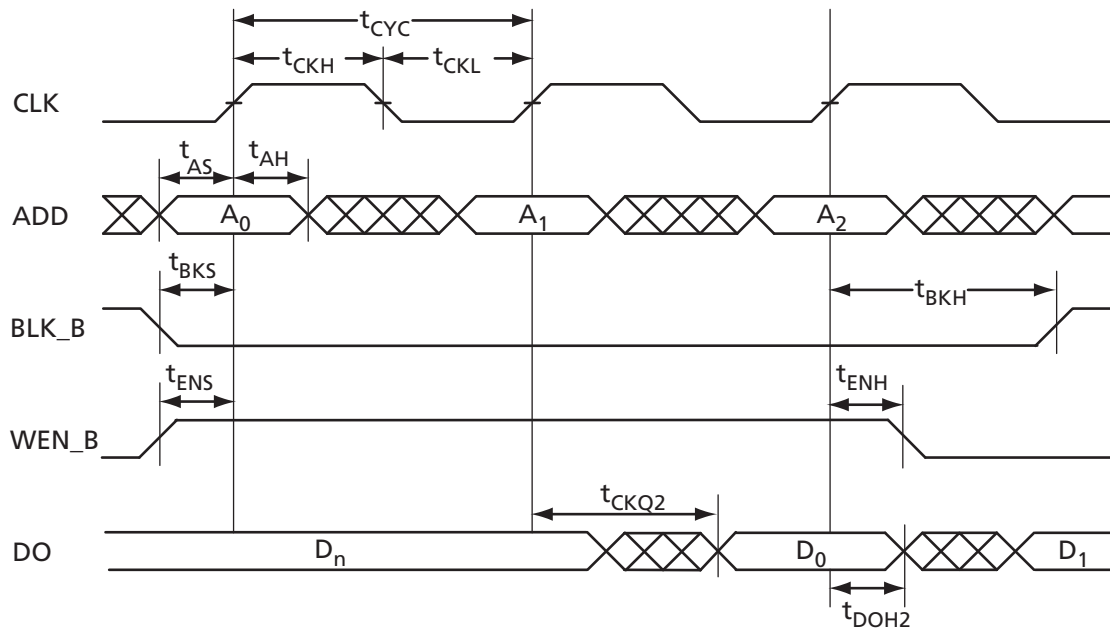

Figure 2-27 • RAM Read for Pipelined Output

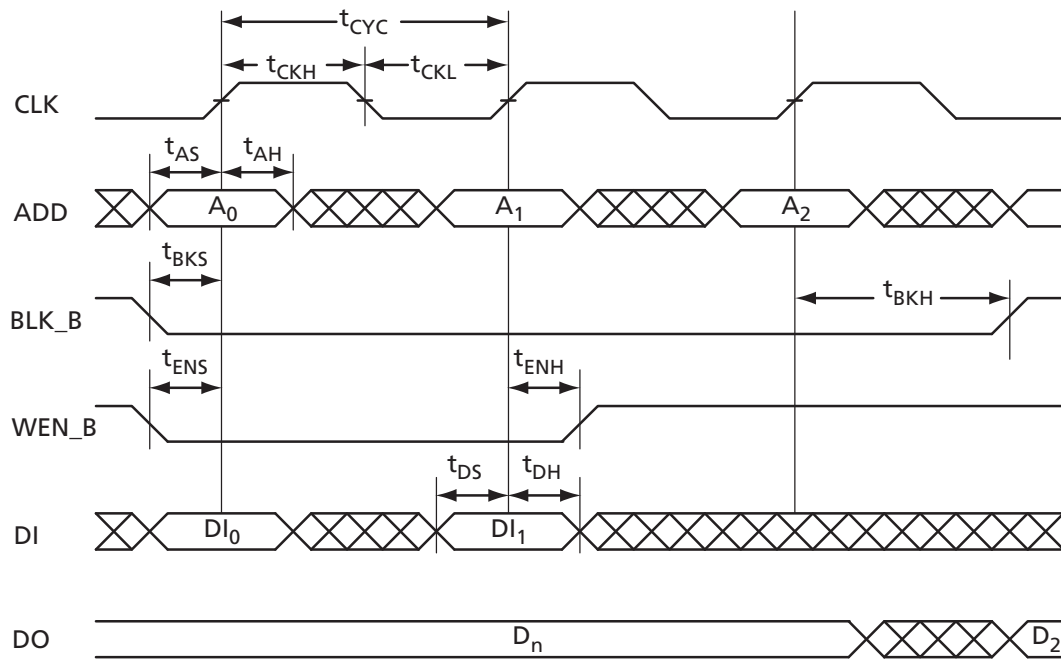

Figure 2-28 • RAM Write, Output Retained (WMODE = 0)

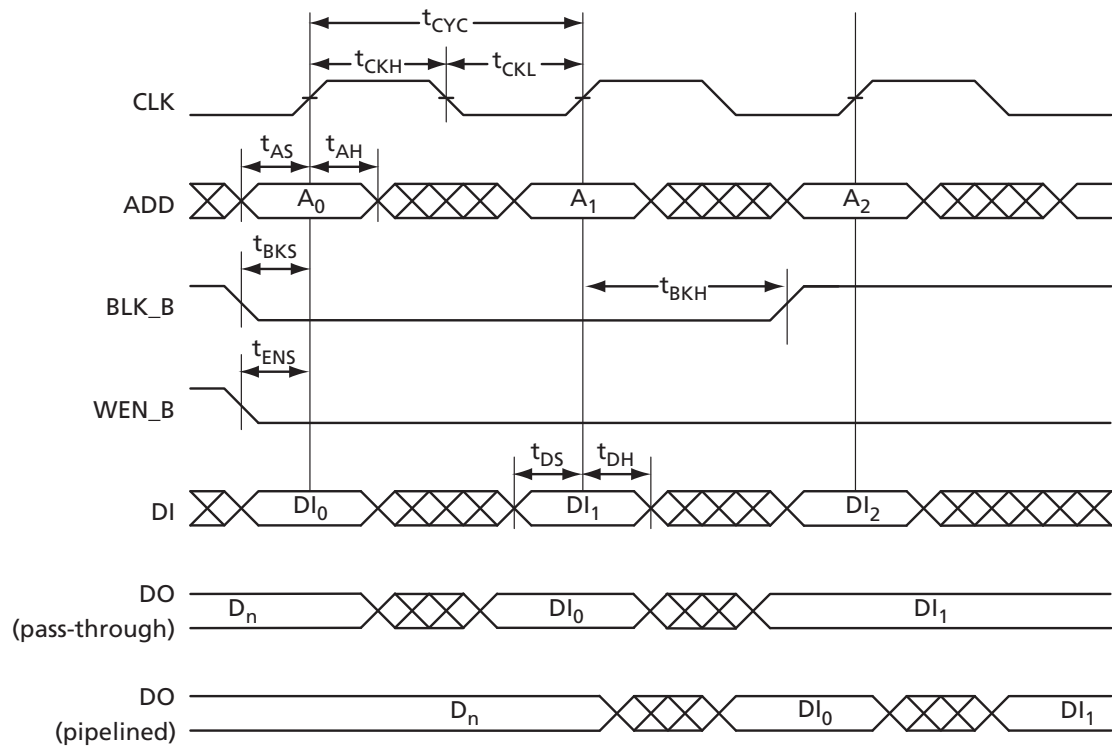

Figure 2-29 • RAM Write, Output as Write Data (WMODE = 1)

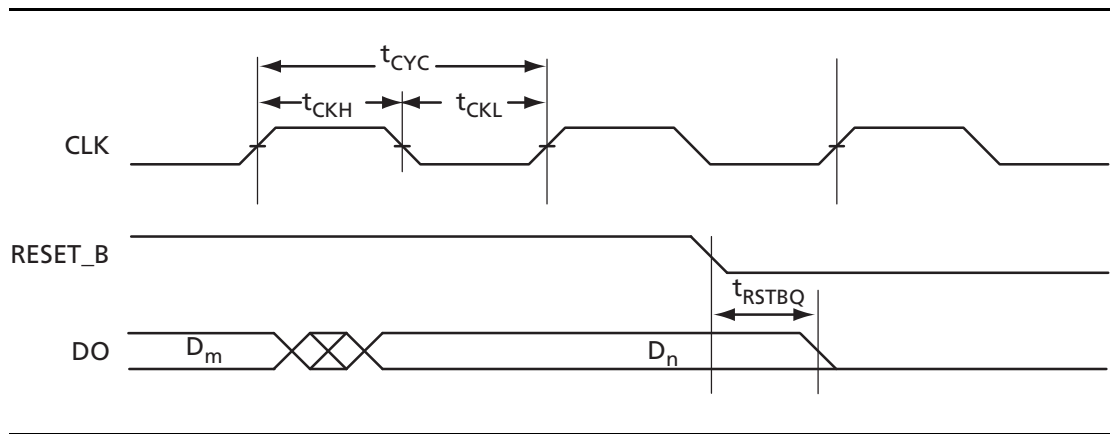

Figure 2-30 • RAM Reset

Timing Characteristics

Table 2-70 • RAM4K9

Commercial-Case Conditions: $T_j = 70^\circ\text{C}$, Worst-Case $V_{CC} = 1.425\text{ V}$

Parameter	Description	-2	-1	Std.	Units
t_{AS}	Address Setup time	0.25	0.28	0.33	ns
t_{AH}	Address Hold time	0.00	0.00	0.00	ns
t_{ENS}	REN_B, WEN_B Setup time	0.14	0.16	0.19	ns
t_{ENH}	REN_B, WEN_B Hold time	0.10	0.11	0.13	ns
t_{BKS}	BLK_B Setup time	0.23	0.27	0.31	ns
t_{BKH}	BLK_B Hold time	0.02	0.02	0.02	ns
t_{DS}	Input data (DI) Setup time	0.18	0.21	0.25	ns
t_{DH}	Input data (DI) Hold time	0.00	0.00	0.00	ns
t_{CKQ1}	Clock High to New Data Valid on DO (output retained, WMODE = 0)	1.79	2.03	2.39	ns
	Clock High to New Data Valid on DO (flow-through, WMODE = 1)	2.36	2.68	3.15	ns
t_{CKQ2}	Clock High to New Data Valid on DO (pipelined)	0.89	1.02	1.20	ns
t_{C2CWWL}	Address collision clk-to-clk delay for reliable write after write on same address; applicable to closing edge	0.33	0.28	0.25	ns
t_{C2CWWH}	Address collision clk-to-clk delay for reliable write after write on same address; applicable to rising edge	0.30	0.26	0.23	ns
t_{C2CRWH}	Address collision clk-to-clk delay for reliable read access after write on same address; applicable to opening edge	0.45	0.38	0.34	ns
t_{C2CWRH}	Address collision clk-to-clk delay for reliable write access after read on same address; applicable to opening edge	0.49	0.42	0.37	ns
t_{RSTBQ}	RESET_B Low to Data Out Low on DO (flow through)	0.92	1.05	1.23	ns
	RESET_B Low to Data Out Low on DO (pipelined)	0.92	1.05	1.23	ns
$t_{REMRSTB}$	RESET_B Removal	0.29	0.33	0.38	ns
$t_{RECRSTB}$	RESET_B Recovery	1.50	1.71	2.01	ns
$t_{MPWRSTB}$	RESET_B Minimum Pulse Width	0.21	0.24	0.29	ns
t_{CYC}	Clock Cycle time	3.23	3.68	4.32	ns
F_{MAX}	Maximum Frequency	310	272	231	MHz

Note: For specific junction temperature and voltage-supply levels, refer to Table 3-6 on page 3-4 for derating values.

Table 2-71 • RAM512X18
 Commercial-Case Conditions: $T_J = 70^\circ\text{C}$, Worst-Case $V_{CC} = 1.425\text{ V}$

Parameter	Description	-2	-1	Std.	Units
t_{AS}	Address setup time	0.25	0.28	0.33	ns
t_{AH}	Address hold time	0.00	0.00	0.00	ns
t_{ENS}	REN_B, WEN_B setup time	0.09	0.10	0.12	ns
t_{ENH}	REN_B, WEN_B hold time	0.06	0.07	0.08	ns
t_{DS}	Input data (DI) setup time	0.18	0.21	0.25	ns
t_{DH}	Input data (DI) hold time	0.00	0.00	0.00	ns
t_{CKQ1}	Clock HIGH to new data valid on DO (output retained, WMODE = 0)	2.16	2.46	2.89	ns
t_{CKQ2}	Clock HIGH to new data valid on DO (pipelined)	0.90	1.02	1.20	ns
t_{C2CRWH}	Address collision clk-to-clk delay for reliable read access after write on same address; applicable to opening edge	0.50	0.43	0.38	ns
t_{C2CWRH}	Address collision clk-to-clk delay for reliable write access after read on same address; applicable to opening edge	0.59	0.50	0.44	ns
t_{RSTBQ}	RESET_B LOW to data out LOW on DO (flow-through)	0.92	1.05	1.23	ns
	RESET_B LOW to data out LOW on DO (pipelined)	0.92	1.05	1.23	ns
$t_{REMRSTB}$	RESET_B removal	0.29	0.33	0.38	ns
$t_{RECRSTB}$	RESET_B recovery	1.50	1.71	2.01	ns
$t_{MPWRSTB}$	RESET_B minimum pulse width	0.21	0.24	0.29	ns
t_{CYC}	Clock cycle time	3.23	3.68	4.32	ns
F_{MAX}	Maximum frequency	310	272	231	MHz

Note: For specific junction temperature and voltage supply levels, refer to [Table 2-6 on page 2-5](#) for derating values.

FIFO

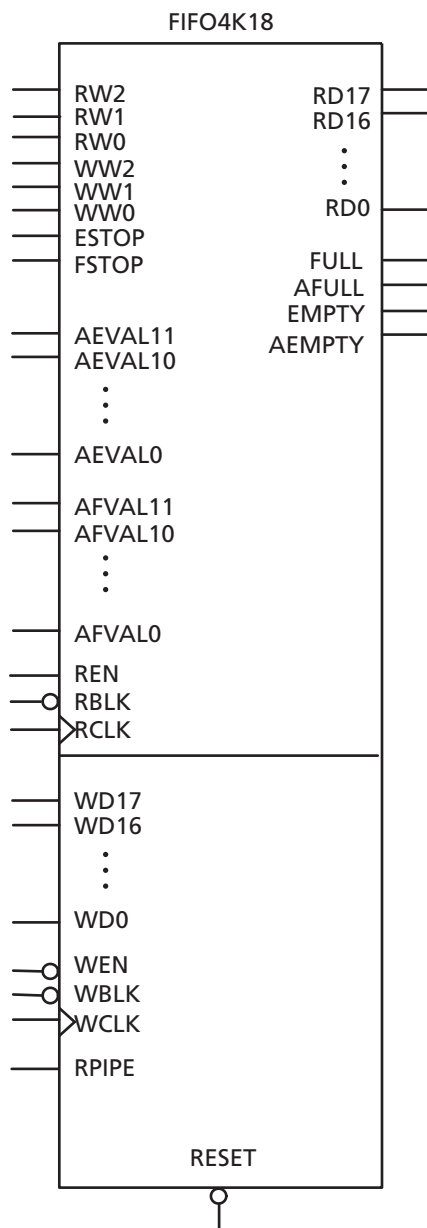

Figure 2-31 • FIFO Model

Timing Waveforms

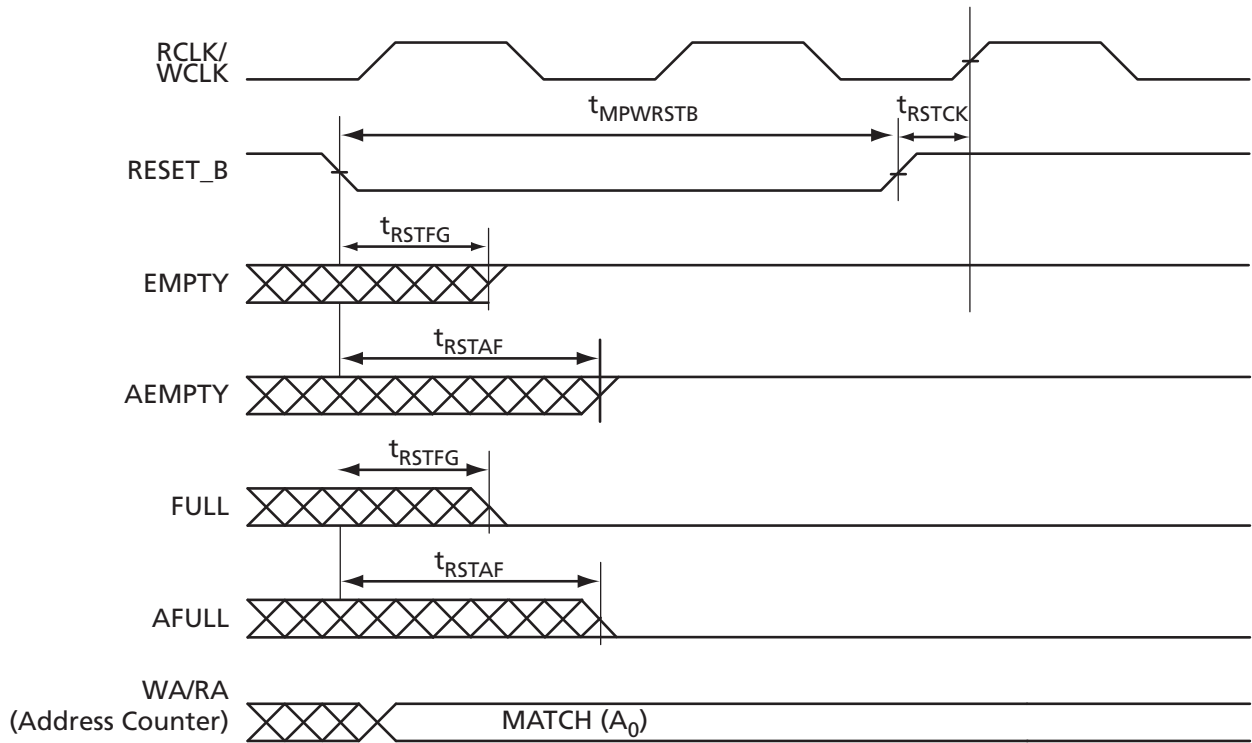

Figure 2-32 • FIFO Reset

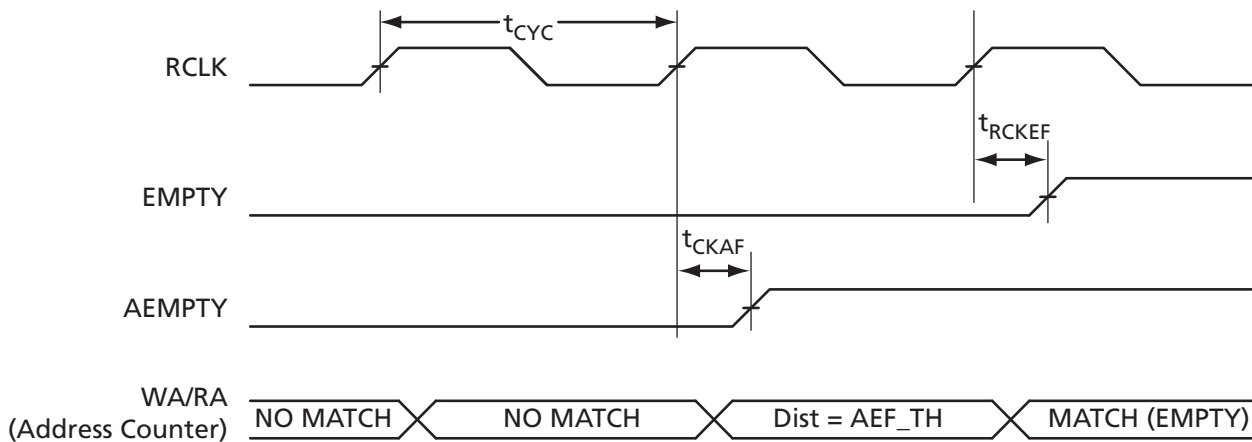
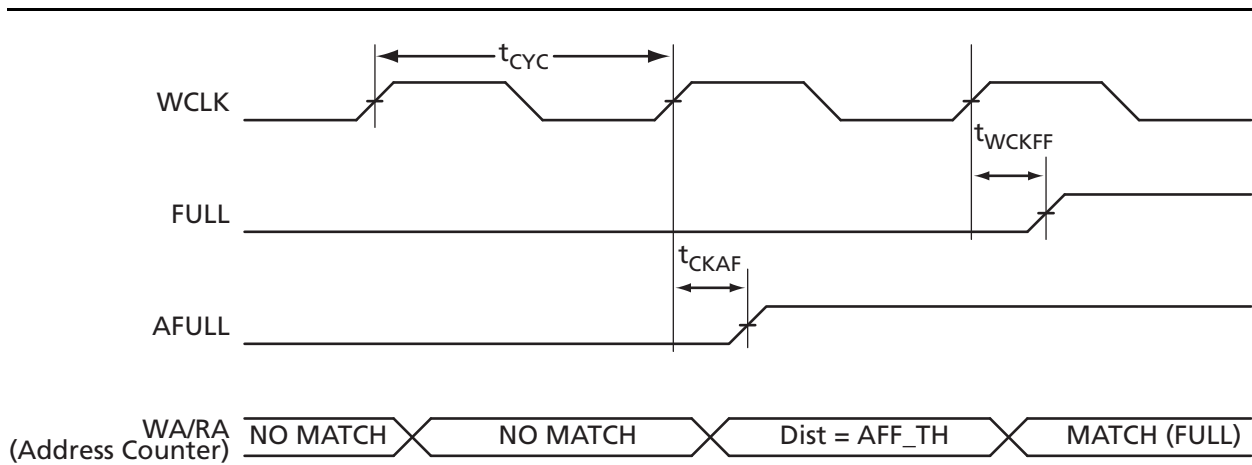
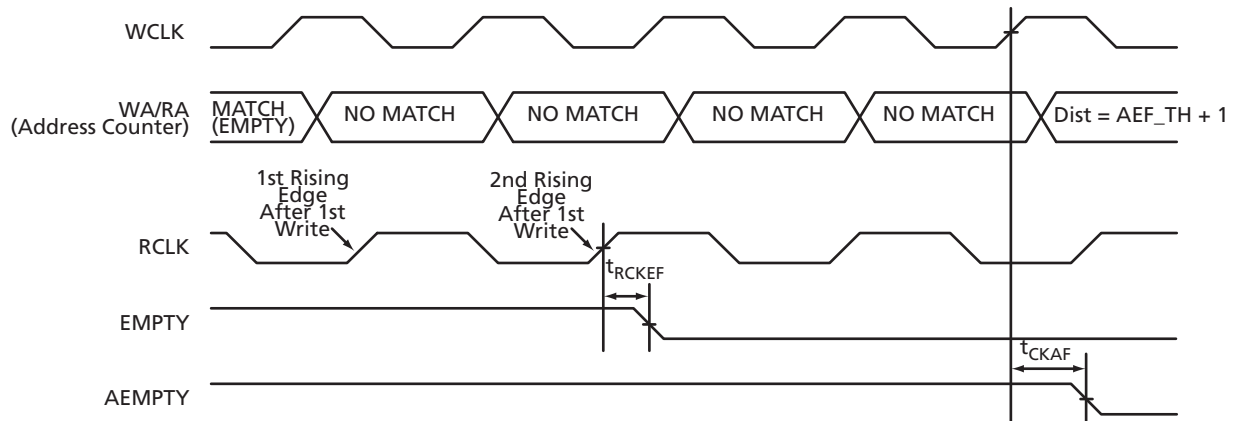
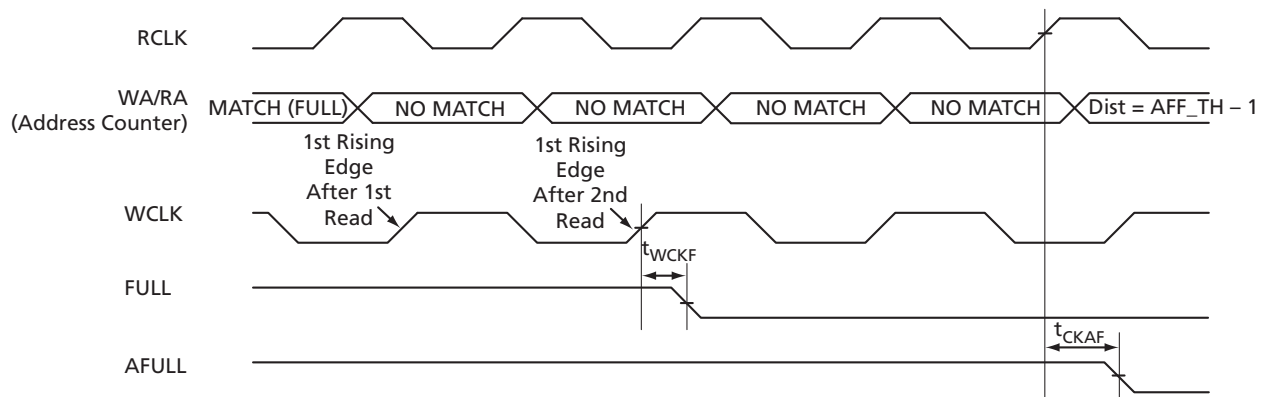

Figure 2-33 • FIFO EMPTY Flag and AEMPTY Flag Assertion

Figure 2-34 • FIFO FULL Flag and AFULL Flag Assertion

Figure 2-35 • FIFO EMPTY Flag and AEMPTY Flag Deassertion

Figure 2-36 • FIFO FULL Flag and AFULL Flag Deassertion

Timing Characteristics

Table 2-72 • FIFO
 Worst Commercial-Case Conditions: $T_j = 70^\circ\text{C}$, $V_{CC} = 1.425\text{ V}$

Parameter	Description	-2	-1	Std.	Units
t_{ENS}	REN_B, WEN_B Setup Time	1.38	1.57	1.84	ns
t_{ENH}	REN_B, WEN_B Hold Time	0.02	0.02	0.02	ns
t_{BKS}	BLK_B Setup Time	0.22	0.25	0.30	ns
t_{BKH}	BLK_B Hold Time	0.00	0.00	0.00	ns
t_{DS}	Input Data (DI) Setup Time	0.18	0.21	0.25	ns
t_{DH}	Input Data (DI) Hold Time	0.00	0.00	0.00	ns
t_{CKQ1}	Clock HIGH to New Data Valid on DO (flow-through)	2.36	2.68	3.15	ns
t_{CKQ2}	Clock HIGH to New Data Valid on DO (pipelined)	0.89	1.02	1.20	ns
t_{RCKEF}	RCLK HIGH to Empty Flag Valid	1.72	1.96	2.30	ns
t_{WCKFF}	WCLK HIGH to Full Flag Valid	1.63	1.86	2.18	ns
t_{CKAF}	Clock HIGH to Almost Empty/Full Flag Valid	6.19	7.05	8.29	ns
t_{RSTFG}	RESET_B LOW to Empty/Full Flag Valid	1.69	1.93	2.27	ns
t_{RSTAF}	RESET_B LOW to Almost Empty/Full Flag Valid	6.13	6.98	8.20	ns
t_{RSTBQ}	RESET_B LOW to Data Out LOW on DO (flow-through)	0.92	1.05	1.23	ns
	RESET_B LOW to Data Out LOW on DO (pipelined)	0.92	1.05	1.23	ns
$t_{REMRSTB}$	RESET_B Removal	0.29	0.33	0.38	ns
$t_{RECRSTB}$	RESET_B Recovery	1.50	1.71	2.01	ns
$t_{MPWRSTB}$	RESET_B Minimum Pulse Width	0.21	0.24	0.29	ns
t_{CYC}	Clock Cycle Time	3.23	3.68	4.32	ns
F_{MAX}	Maximum Frequency for FIFO	310	272	231	MHz

Note: For specific junction temperature and voltage supply levels, refer to [Table 2-6 on page 2-5](#) for derating values.

Embedded FlashROM Characteristics

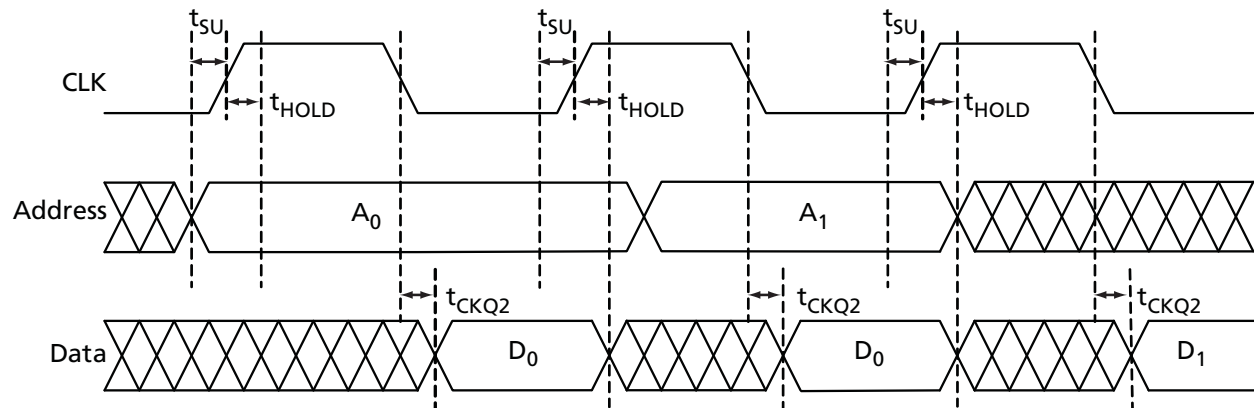

Figure 2-37 • Timing Diagram

Timing Characteristics

Table 2-73 • Embedded FlashROM Access Time
Commercial-Case Conditions: $T_J = 70^\circ\text{C}$, Worst-Case $V_{CC} = 1.425\text{ V}$

Parameter	Description	-2	-1	Std.	Units
t_{SU}	Address Setup Time	0.53	0.61	0.71	ns
t_{HOLD}	Address Hold Time	0.00	0.00	0.00	ns
t_{CKQ2}	Clock to Out	16.23	18.48	21.73	ns
F_{MAX}	Maximum Clock Frequency	15.00	15.00	15.00	MHz

JTAG 1532 Characteristics

JTAG timing delays do not include JTAG I/Os. To obtain complete JTAG timing, add I/O buffer delays to the corresponding standard selected; refer to the I/O timing characteristics in the "User I/O Characteristics" section on page 2-11 for more details.

Timing Characteristics

Table 2-74 • JTAG 1532

Commercial-Case Conditions: $T_J = 70^\circ\text{C}$, Worst-Case $V_{CC} = 1.425\text{ V}$

Parameter	Description	-2	-1	Std.	Units
t_{DISU}	Test Data Input Setup Time	0.53	0.60	0.71	ns
t_{DIHD}	Test Data Input Hold Time	1.07	1.21	1.42	ns
t_{TMSSU}	Test Mode Select Setup Time	0.53	0.60	0.71	ns
t_{TMDHD}	Test Mode Select Hold Time	1.07	1.21	1.42	ns
t_{TCK2Q}	Clock to Q (data out)	6.39	7.24	8.52	ns
t_{RSTB2Q}	Reset to Q (data out)	21.31	24.15	28.41	ns
F_{TCKMAX}	TCK Maximum Frequency	23.00	20.00	17.00	MHz
$t_{TRSTREM}$	ResetB Removal Time	0.00	0.00	0.00	ns
$t_{TRSTREC}$	ResetB Recovery Time	0.21	0.24	0.28	ns
$t_{TRSTMPW}$	ResetB Minimum Pulse	TBD	TBD	TBD	ns

Note: For specific junction temperature and voltage supply levels, refer to Table 2-6 on page 2-5 for derating values.

Part Number and Revision Date

Part Number 51700111-002-1

Revised November 2008

List of Changes

The following table lists critical changes that were made in the current version of the chapter.

Previous Version	Changes in Current Version (Advance v0.2)	Page
Advance v0.1 (October 2008)	Table 2-2 · Recommended Operating Conditions ^{1, 2} was revised to add VMV to the V _{CCI} row. The following table note was added: "VMV pins must be connected to the corresponding V _{CCI} pins."	2-2
	The values in Table 2-7 · Quiescent Supply Current Characteristics were revised for A3PN010, A3PN015, and A3PN020.	2-6
	A table note, "All LVCMOS 3.3 V software macros support LVCMOS 3.3 V wide range, as specified in the JESD8-B specification," was added to Table 2-14 · Summary of Maximum and Minimum DC Input and Output Levels, Table 2-18 · Summary of I/O Timing Characteristics—Software Default Settings (at 35 pF), and Table 2-19 · Summary of I/O Timing Characteristics—Software Default Settings (at 10 pF).	2-15, 2-17
	3.3 V LVCMOS Wide Range was added to Table 2-21 · I/O Output Buffer Maximum Resistances ¹ and Table 2-23 · I/O Short Currents I _{OSH} /I _{OSL} .	2-18, 2-19

Actel Safety Critical, Life Support, and High-Reliability Applications Policy

The Actel products described in this advance status datasheet may not have completed Actel's qualification process. Actel may amend or enhance products during the product introduction and qualification process, resulting in changes in device functionality or performance. It is the responsibility of each customer to ensure the fitness of any Actel product (but especially a new product) for a particular purpose, including appropriateness for safety-critical, life-support, and other high-reliability applications. Consult Actel's Terms and Conditions for specific liability exclusions relating to life-support applications. A reliability report covering all of Actel's products is available on the Actel website at http://www.actel.com/documents/ORT_Report.pdf. Actel also offers a variety of enhanced qualification and lot acceptance screening procedures. Contact your local Actel sales office for additional reliability information.

3 – Package Pin Assignments

48-Pin QFN

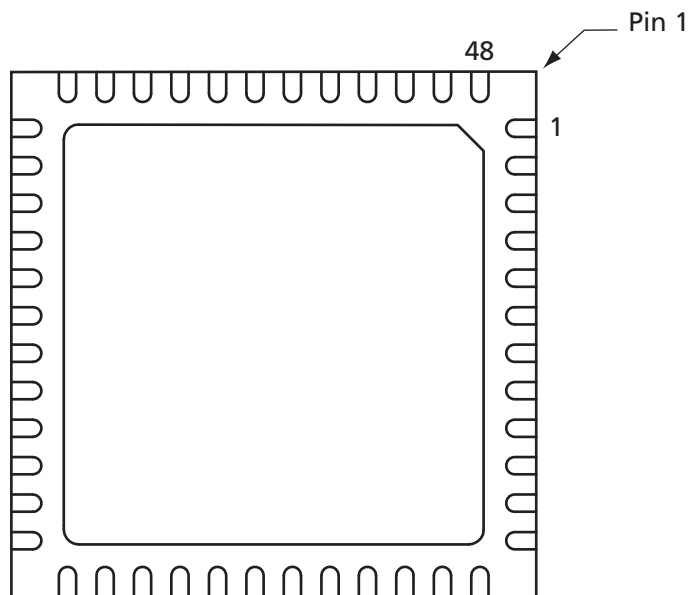

Notes:

1. This is the bottom view of the package.
2. The die attach paddle of the package is tied to ground (GND).

Note

For Package Manufacturing and Environmental information, visit the Resource Center at <http://www.actel.com/products/solutions/package/docs.aspx>.

48-Pin QFN	
Pin Number	A3PN010 Function
1	GEC0/IO37RSB1
2	IO36RSB1
3	GEA0/IO34RSB1
4	IO22RSB1
5	GND
6	VCCIB1
7	IO24RSB1
8	IO33RSB1
9	IO26RSB1
10	IO32RSB1
11	IO27RSB1
12	IO29RSB1
13	IO30RSB1
14	IO31RSB1
15	IO28RSB1
16	IO25RSB1
17	IO23RSB1
18	VCC
19	VCCIB1
20	IO17RSB1
21	IO14RSB1
22	TCK
23	TDI
24	TMS
25	VPUMP
26	TDO
27	TRST
28	VJTAG
29	IO11RSB0
30	IO10RSB0
31	IO09RSB0
32	IO08RSB0
33	VCCIB0
34	GND
35	VCC
36	IO07RSB0

48-Pin QFN	
Pin Number	A3PN010 Function
37	IO06RSB0
38	GDA0/IO05RSB0
39	IO03RSB0
40	GDC0/IO01RSB0
41	IO12RSB1
42	IO13RSB1
43	IO15RSB1
44	IO16RSB1
45	IO18RSB1
46	IO19RSB1
47	IO20RSB1
48	IO21RSB1

48-Pin QFN	
Pin Number	A3PN030Z Function
1	IO82RSB1
2	GEC0/IO73RSB1
3	GEA0/IO72RSB1
4	GEB0/IO71RSB1
5	GND
6	VCCIB1
7	IO68RSB1
8	IO67RSB1
9	IO66RSB1
10	IO65RSB1
11	IO64RSB1
12	IO62RSB1
13	IO61RSB1
14	IO60RSB1
15	IO57RSB1
16	IO55RSB1
17	IO53RSB1
18	VCC
19	V _{CC} B1
20	IO46RSB1
21	IO42RSB1
22	TCK
23	TDI
24	TMS
25	VPUMP
26	TDO
27	TRST
28	VJTAG
29	IO38RSB0
30	GDB0/IO34RSB0
31	GDA0/IO33RSB0
32	GDC0/IO32RSB0
33	V _{CC} B0
34	GND
35	VCC
36	IO25RSB0

48-Pin QFN	
Pin Number	A3PN030Z Function
37	IO24RSB0
38	IO22RSB0
39	IO20RSB0
40	IO18RSB0
41	IO16RSB0
42	IO14RSB0
43	IO10RSB0
44	IO08RSB0
45	IO06RSB0
46	IO04RSB0
47	IO02RSB0
48	IO00RSB0

68-Pin QFN

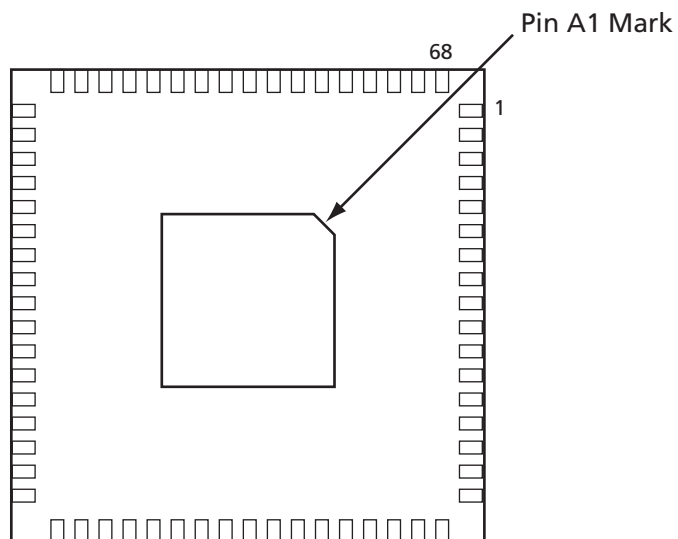

Notes:

1. This is the bottom view of the package.
2. The die attach paddle of the package is tied to ground (GND).

Note

For Package Manufacturing and Environmental information, visit the Resource Center at <http://www.actel.com/products/solutions/package/docs.aspx>.

68-Pin QFN		68-Pin QFN	
Pin Number	A3PN015 Function	Pin Number	A3PN015 Function
1	IO60RSB2	37	TRST
2	IO54RSB2	38	VJTAG
3	IO52RSB2	39	IO17RSB0
4	IO50RSB2	40	IO16RSB0
5	IO49RSB2	41	GDA0/IO15RSB0
6	GEC0/IO48RSB2	42	GDC0/IO14RSB0
7	GEA0/IO47RSB2	43	IO13RSB0
8	VCC	44	VCCIB0
9	GND	45	GND
10	VCCIB2	46	VCC
11	IO46RSB2	47	IO12RSB0
12	IO45RSB2	48	IO11RSB0
13	IO44RSB2	49	IO09RSB0
14	IO43RSB2	50	IO05RSB0
15	IO42RSB2	51	IO00RSB0
16	IO41RSB2	52	IO07RSB0
17	IO40RSB2	53	IO03RSB0
18	IO39RSB1	54	IO18RSB1
19	IO37RSB1	55	IO20RSB1
20	IO35RSB1	56	IO22RSB1
21	IO33RSB1	57	IO24RSB1
22	IO31RSB1	58	IO28RSB1
23	IO30RSB1	59	NC
24	VCC	60	GND
25	GND	61	NC
26	VCCIB1	62	IO32RSB1
27	IO27RSB1	63	IO34RSB1
28	IO25RSB1	64	IO36RSB1
29	IO23RSB1	65	IO61RSB2
30	IO21RSB1	66	IO58RSB2
31	IO19RSB1	67	IO56RSB2
32	TCK	68	IO63RSB2
33	TDI		
34	TMS		
35	VPUMP		
36	TDO		

68-Pin QFN	
Pin Number	A3PN020 Function
1	IO60RSB2
2	IO54RSB2
3	IO52RSB2
4	IO50RSB2
5	IO49RSB2
6	GEC0/IO48RSB2
7	GEA0/IO47RSB2
8	VCC
9	GND
10	VCCIB2
11	IO46RSB2
12	IO45RSB2
13	IO44RSB2
14	IO43RSB2
15	IO42RSB2
16	IO41RSB2
17	IO40RSB2
18	IO39RSB1
19	IO37RSB1
20	IO35RSB1
21	IO33RSB1
22	IO31RSB1
23	IO30RSB1
24	VCC
25	GND
26	VCCIB1
27	IO27RSB1
28	IO25RSB1
29	IO23RSB1
30	IO21RSB1
31	IO19RSB1
32	TCK
33	TDI
34	TMS
35	VPUMP
36	TDO

68-Pin QFN	
Pin Number	A3PN020 Function
37	TRST
38	VJTAG
39	IO17RSB0
40	IO16RSB0
41	GDA0/IO15RSB0
42	GDC0/IO14RSB0
43	IO13RSB0
44	VCCIB0
45	GND
46	VCC
47	IO12RSB0
48	IO11RSB0
49	IO09RSB0
50	IO05RSB0
51	IO00RSB0
52	IO07RSB0
53	IO03RSB0
54	IO18RSB1
55	IO20RSB1
56	IO22RSB1
57	IO24RSB1
58	IO28RSB1
59	NC
60	GND
61	NC
62	IO32RSB1
63	IO34RSB1
64	IO36RSB1
65	IO61RSB2
66	IO58RSB2
67	IO56RSB2
68	IO63RSB2

68-Pin QFN		68-Pin QFN	
Pin Number	A3PN030 Function	Pin Number	A3PN030 Function
1	IO82RSB1	37	TRST
2	IO80RSB1	38	VJTAG
3	IO78RSB1	39	IO40RSB0
4	IO76RSB1	40	IO37RSB0
5	GEC0/IO73RSB1	41	GDB0/IO34RSB0
6	GEA0/IO72RSB1	42	GDA0/IO33RSB0
7	GEB0/IO71RSB1	43	GDC0/IO32RSB0
8	VCC	44	VCCIB0
9	GND	45	GND
10	VCCIB1	46	VCC
11	IO68RSB1	47	IO31RSB0
12	IO67RSB1	48	IO29RSB0
13	IO66RSB1	49	IO28RSB0
14	IO65RSB1	50	IO27RSB0
15	IO64RSB1	51	IO25RSB0
16	IO63RSB1	52	IO24RSB0
17	IO62RSB1	53	IO22RSB0
18	IO60RSB1	54	IO21RSB0
19	IO58RSB1	55	IO19RSB0
20	IO56RSB1	56	IO17RSB0
21	IO54RSB1	57	IO15RSB0
22	IO52RSB1	58	IO14RSB0
23	IO51RSB1	59	VCCIB0
24	VCC	60	GND
25	GND	61	VCC
26	VCCIB1	62	IO12RSB0
27	IO50RSB1	63	IO10RSB0
28	IO48RSB1	64	IO08RSB0
29	IO46RSB1	65	IO06RSB0
30	IO44RSB1	66	IO04RSB0
31	IO42RSB1	67	IO02RSB0
32	TCK	68	IO00RSB0
33	TDI		
34	TMS		
35	VPUMP		
36	TDO		

68-Pin QFN	
Pin Number	A3PN030Z Function
1	IO82RSB1
2	IO80RSB1
3	IO78RSB1
4	IO76RSB1
5	GEC0/IO73RSB1
6	GEA0/IO72RSB1
7	GEB0/IO71RSB1
8	VCC
9	GND
10	VCCIB1
11	IO68RSB1
12	IO67RSB1
13	IO66RSB1
14	IO65RSB1
15	IO64RSB1
16	IO63RSB1
17	IO62RSB1
18	IO60RSB1
19	IO58RSB1
20	IO56RSB1
21	IO54RSB1
22	IO52RSB1
23	IO51RSB1
24	VCC
25	GND
26	VCCIB1
27	IO50RSB1
28	IO48RSB1
29	IO46RSB1
30	IO44RSB1
31	IO42RSB1
32	TCK
33	TDI
34	TMS
35	VPUMP
36	TDO

68-Pin QFN	
Pin Number	A3PN030Z Function
37	TRST
38	VJTAG
39	IO40RSB0
40	IO37RSB0
41	GDB0/IO34RSB0
42	GDA0/IO33RSB0
43	GDC0/IO32RSB0
44	VCCIB0
45	GND
46	VCC
47	IO31RSB0
48	IO29RSB0
49	IO28RSB0
50	IO27RSB0
51	IO25RSB0
52	IO24RSB0
53	IO22RSB0
54	IO21RSB0
55	IO19RSB0
56	IO17RSB0
57	IO15RSB0
58	IO14RSB0
59	VCCIB0
60	GND
61	VCC
62	IO12RSB0
63	IO10RSB0
64	IO08RSB0
65	IO06RSB0
66	IO04RSB0
67	IO02RSB0
68	IO00RSB0

100-Pin VQFP

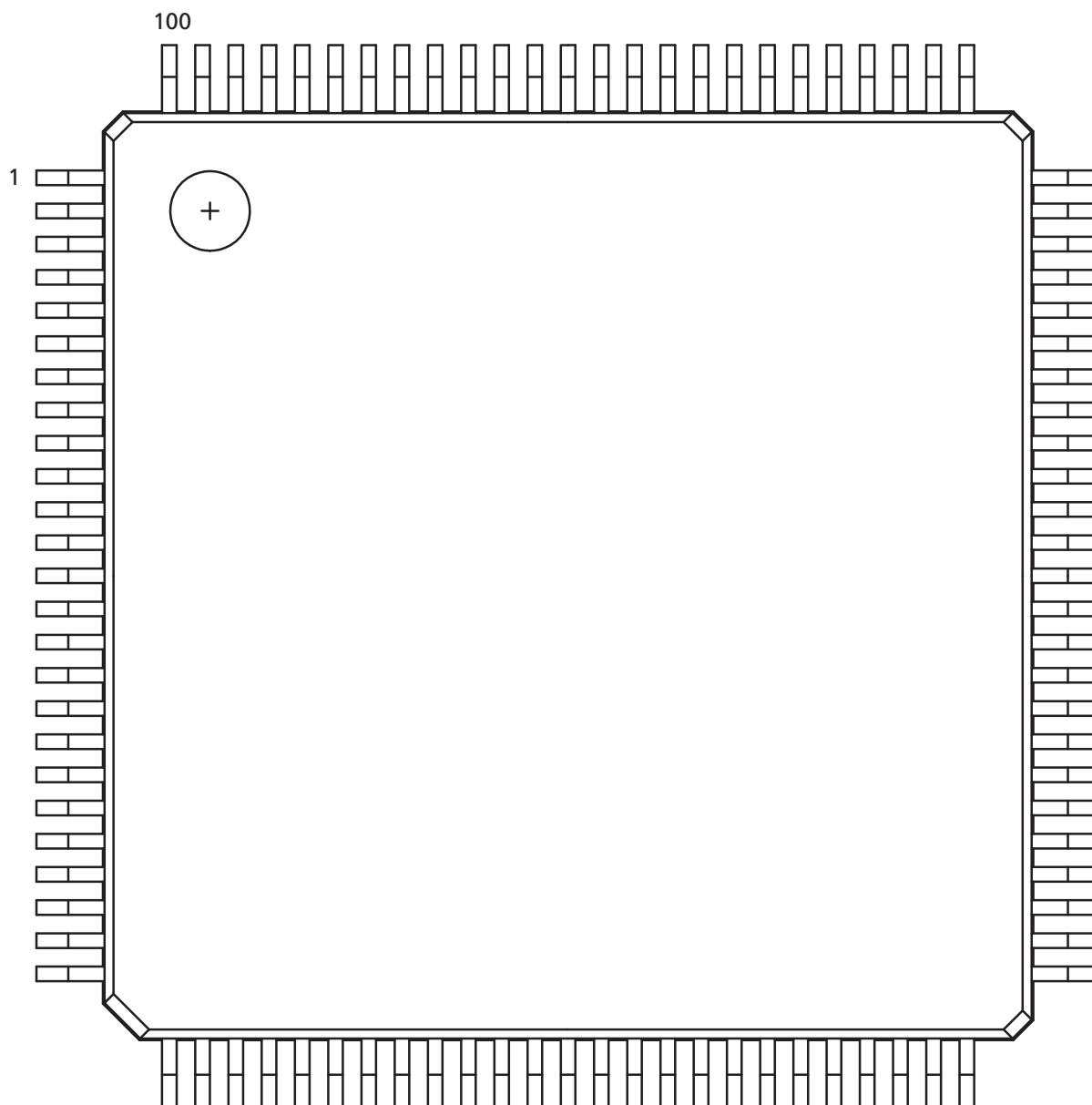

Note: This is the top view of the package.

Note

For Package Manufacturing and Environmental information, visit the Resource Center at <http://www.actel.com/products/solutions/package/docs.aspx>.

100-Pin VQFP		100-Pin VQFP		100-Pin VQFP	
Pin Number	A3PN030 Function	Pin Number	A3PN030 Function	Pin Number	A3PN030 Function
1	GND	37	VCC	73	IO27RSB0
2	IO82RSB1	38	GND	74	IO26RSB0
3	IO81RSB1	39	VCCIB1	75	IO25RSB0
4	IO80RSB1	40	IO49RSB1	76	IO24RSB0
5	IO79RSB1	41	IO47RSB1	77	IO23RSB0
6	IO78RSB1	42	IO46RSB1	78	IO22RSB0
7	IO77RSB1	43	IO45RSB1	79	IO21RSB0
8	IO76RSB1	44	IO44RSB1	80	IO20RSB0
9	GND	45	IO43RSB1	81	IO19RSB0
10	IO75RSB1	46	IO42RSB1	82	IO18RSB0
11	IO74RSB1	47	TCK	83	IO17RSB0
12	GEC0/IO73RSB1	48	TDI	84	IO16RSB0
13	GEA0/IO72RSB1	49	TMS	85	IO15RSB0
14	GEB0/IO71RSB1	50	NC	86	IO14RSB0
15	IO70RSB1	51	GND	87	VCCIB0
16	IO69RSB1	52	VPUMP	88	GND
17	VCC	53	NC	89	VCC
18	VCCIB1	54	TDO	90	IO12RSB0
19	IO68RSB1	55	TRST	91	IO10RSB0
20	IO67RSB1	56	VJTAG	92	IO08RSB0
21	IO66RSB1	57	IO41RSB0	93	IO07RSB0
22	IO65RSB1	58	IO40RSB0	94	IO06RSB0
23	IO64RSB1	59	IO39RSB0	95	IO05RSB0
24	IO63RSB1	60	IO38RSB0	96	IO04RSB0
25	IO62RSB1	61	IO37RSB0	97	IO03RSB0
26	IO61RSB1	62	IO36RSB0	98	IO02RSB0
27	IO60RSB1	63	GDB0/IO34RSB0	99	IO01RSB0
28	IO59RSB1	64	GDA0/IO33RSB0	100	IO00RSB0
29	IO58RSB1	65	GDC0/IO32RSB0		
30	IO57RSB1	66	VCCIB0		
31	IO56RSB1	67	GND		
32	IO55RSB1	68	VCC		
33	IO54RSB1	69	IO31RSB0		
34	IO53RSB1	70	IO30RSB0		
35	IO52RSB1	71	IO29RSB0		
36	IO51RSB1	72	IO28RSB0		

100-Pin VQFP		100-Pin VQFP		100-Pin VQFP	
Pin Number	A3PN030Z Function	Pin Number	A3PN030Z Function	Pin Number	A3PN030Z Function
1	GND	37	VCC	73	IO27RSB0
2	IO82RSB1	38	GND	74	IO26RSB0
3	IO81RSB1	39	VCCIB1	75	IO25RSB0
4	IO80RSB1	40	IO49RSB1	76	IO24RSB0
5	IO79RSB1	41	IO47RSB1	77	IO23RSB0
6	IO78RSB1	42	IO46RSB1	78	IO22RSB0
7	IO77RSB1	43	IO45RSB1	79	IO21RSB0
8	IO76RSB1	44	IO44RSB1	80	IO20RSB0
9	GND	45	IO43RSB1	81	IO19RSB0
10	IO75RSB1	46	IO42RSB1	82	IO18RSB0
11	IO74RSB1	47	TCK	83	IO17RSB0
12	GEC0/IO73RSB1	48	TDI	84	IO16RSB0
13	GEA0/IO72RSB1	49	TMS	85	IO15RSB0
14	GEB0/IO71RSB1	50	NC	86	IO14RSB0
15	IO70RSB1	51	GND	87	VCCIB0
16	IO69RSB1	52	VPUMP	88	GND
17	VCC	53	NC	89	VCC
18	VCCIB1	54	TDO	90	IO12RSB0
19	IO68RSB1	55	TRST	91	IO10RSB0
20	IO67RSB1	56	VJTAG	92	IO08RSB0
21	IO66RSB1	57	IO41RSB0	93	IO07RSB0
22	IO65RSB1	58	IO40RSB0	94	IO06RSB0
23	IO64RSB1	59	IO39RSB0	95	IO05RSB0
24	IO63RSB1	60	IO38RSB0	96	IO04RSB0
25	IO62RSB1	61	IO37RSB0	97	IO03RSB0
26	IO61RSB1	62	IO36RSB0	98	IO02RSB0
27	IO60RSB1	63	GDB0/IO34RSB0	99	IO01RSB0
28	IO59RSB1	64	GDA0/IO33RSB0	100	IO00RSB0
29	IO58RSB1	65	GDC0/IO32RSB0		
30	IO57RSB1	66	VCCIB0		
31	IO56RSB1	67	GND		
32	IO55RSB1	68	VCC		
33	IO54RSB1	69	IO31RSB0		
34	IO53RSB1	70	IO30RSB0		
35	IO52RSB1	71	IO29RSB0		
36	IO51RSB1	72	IO28RSB0		

100-Pin VQFP		100-Pin VQFP		100-Pin VQFP	
Pin Number	A3PN060 Function	Pin Number	A3PN060 Function	Pin Number	A3PN060 Function
1	GND	37	VCC	73	GBA2/IO25RSB0
2	GAA2/IO51RSB1	38	GND	74	VMV0
3	IO52RSB1	39	VCCIB1	75	GNDQ
4	GAB2/IO53RSB1	40	IO60RSB1	76	GBA1/IO24RSB0
5	IO95RSB1	41	IO59RSB1	77	GBA0/IO23RSB0
6	GAC2/IO94RSB1	42	IO58RSB1	78	GBB1/IO22RSB0
7	IO93RSB1	43	IO57RSB1	79	GBB0/IO21RSB0
8	IO92RSB1	44	GDC2/IO56RSB1	80	GBC1/IO20RSB0
9	GND	45	GDB2/IO55RSB1	81	GBC0/IO19RSB0
10	GFB1/IO87RSB1	46	GDA2/IO54RSB1	82	IO18RSB0
11	GFB0/IO86RSB1	47	TCK	83	IO17RSB0
12	VCOMPLF	48	TDI	84	IO15RSB0
13	GFA0/IO85RSB1	49	TMS	85	IO13RSB0
14	VCCPLF	50	VMV1	86	IO11RSB0
15	GFA1/IO84RSB1	51	GND	87	VCCIB0
16	GFA2/IO83RSB1	52	VPUMP	88	GND
17	VCC	53	NC	89	VCC
18	VCCIB1	54	TDO	90	IO10RSB0
19	GEC1/IO77RSB1	55	TRST	91	IO09RSB0
20	GEB1/IO75RSB1	56	VJTAG	92	IO08RSB0
21	GEB0/IO74RSB1	57	GDA1/IO49RSB0	93	GAC1/IO07RSB0
22	GEA1/IO73RSB1	58	GDC0/IO46RSB0	94	GAC0/IO06RSB0
23	GEA0/IO72RSB1	59	GDC1/IO45RSB0	95	GAB1/IO05RSB0
24	VMV1	60	GCC2/IO43RSB0	96	GAB0/IO04RSB0
25	GNDQ	61	GCB2/IO42RSB0	97	GAA1/IO03RSB0
26	GEA2/IO71RSB1	62	GCA0/IO40RSB0	98	GAA0/IO02RSB0
27	GEB2/IO70RSB1	63	GCA1/IO39RSB0	99	IO01RSB0
28	GEC2/IO69RSB1	64	GCC0/IO36RSB0	100	IO00RSB0
29	IO68RSB1	65	GCC1/IO35RSB0		
30	IO67RSB1	66	VCCIB0		
31	IO66RSB1	67	GND		
32	IO65RSB1	68	VCC		
33	IO64RSB1	69	IO31RSB0		
34	IO63RSB1	70	GBC2/IO29RSB0		
35	IO62RSB1	71	GBB2/IO27RSB0		
36	IO61RSB1	72	IO26RSB0		

100-Pin VQFP		100-Pin VQFP		100-Pin VQFP	
Pin Number	A3PN060Z	Pin Number	A3PN060Z	Pin Number	A3PN060Z
1	GND	37	VCC	73	GBA2/IO25RSB0
2	GAA2/IO51RSB1	38	GND	74	VMV0
3	IO52RSB1	39	VCCIB1	75	GNDQ
4	GAB2/IO53RSB1	40	IO60RSB1	76	GBA1/IO24RSB0
5	IO95RSB1	41	IO59RSB1	77	GBA0/IO23RSB0
6	GAC2/IO94RSB1	42	IO58RSB1	78	GBB1/IO22RSB0
7	IO93RSB1	43	IO57RSB1	79	GBB0/IO21RSB0
8	IO92RSB1	44	GDC2/IO56RSB1	80	GBC1/IO20RSB0
9	GND	45	GDB2/IO55RSB1	81	GBC0/IO19RSB0
10	GFB1/IO87RSB1	46	GDA2/IO54RSB1	82	IO18RSB0
11	GFB0/IO86RSB1	47	TCK	83	IO17RSB0
12	VCOMPLF	48	TDI	84	IO15RSB0
13	GFA0/IO85RSB1	49	TMS	85	IO13RSB0
14	VCCPLF	50	VMV1	86	IO11RSB0
15	GFA1/IO84RSB1	51	GND	87	VCCIB0
16	GFA2/IO83RSB1	52	VPUMP	88	GND
17	VCC	53	NC	89	VCC
18	VCCIB1	54	TDO	90	IO10RSB0
19	GEC1/IO77RSB1	55	TRST	91	IO09RSB0
20	GEB1/IO75RSB1	56	VJTAG	92	IO08RSB0
21	GEB0/IO74RSB1	57	GDA1/IO49RSB0	93	GAC1/IO07RSB0
22	GEA1/IO73RSB1	58	GDC0/IO46RSB0	94	GAC0/IO06RSB0
23	GEA0/IO72RSB1	59	GDC1/IO45RSB0	95	GAB1/IO05RSB0
24	VMV1	60	GCC2/IO43RSB0	96	GAB0/IO04RSB0
25	GNDQ	61	GCB2/IO42RSB0	97	GAA1/IO03RSB0
26	GEA2/IO71RSB1	62	GCA0/IO40RSB0	98	GAA0/IO02RSB0
27	GEB2/IO70RSB1	63	GCA1/IO39RSB0	99	IO01RSB0
28	GEC2/IO69RSB1	64	GCC0/IO36RSB0	100	IO00RSB0
29	IO68RSB1	65	GCC1/IO35RSB0		
30	IO67RSB1	66	VCCIB0		
31	IO66RSB1	67	GND		
32	IO65RSB1	68	VCC		
33	IO64RSB1	69	IO31RSB0		
34	IO63RSB1	70	GBC2/IO29RSB0		
35	IO62RSB1	71	GBB2/IO27RSB0		
36	IO61RSB1	72	IO26RSB0		

100-Pin VQFP		100-Pin VQFP		100-Pin VQFP	
Pin Number	A3PN125 Function	Pin Number	A3PN125 Function	Pin Number	A3PN125 Function
1	GND	37	VCC	73	GBA2/IO41RSB0
2	GAA2/IO67RSB1	38	GND	74	VMV0
3	IO68RSB1	39	VCCIB1	75	GNDQ
4	GAB2/IO69RSB1	40	IO87RSB1	76	GBA1/IO40RSB0
5	IO132RSB1	41	IO84RSB1	77	GBA0/IO39RSB0
6	GAC2/IO131RSB1	42	IO81RSB1	78	GBB1/IO38RSB0
7	IO130RSB1	43	IO75RSB1	79	GBB0/IO37RSB0
8	IO129RSB1	44	GDC2/IO72RSB1	80	GBC1/IO36RSB0
9	GND	45	GDB2/IO71RSB1	81	GBC0/IO35RSB0
10	GFB1/IO124RSB1	46	GDA2/IO70RSB1	82	IO32RSB0
11	GFB0/IO123RSB1	47	TCK	83	IO28RSB0
12	VCOMPLF	48	TDI	84	IO25RSB0
13	GFA0/IO122RSB1	49	TMS	85	IO22RSB0
14	VCCPLF	50	VMV1	86	IO19RSB0
15	GFA1/IO121RSB1	51	GND	87	VCCIB0
16	GFA2/IO120RSB1	52	VPUMP	88	GND
17	VCC	53	NC	89	VCC
18	VCCIB1	54	TDO	90	IO15RSB0
19	GEC0/IO111RSB1	55	TRST	91	IO13RSB0
20	GEB1/IO110RSB1	56	V _{JTAG}	92	IO11RSB0
21	GEB0/IO109RSB1	57	GDA1/IO65RSB0	93	IO09RSB0
22	GEA1/IO108RSB1	58	GDC0/IO62RSB0	94	IO07RSB0
23	GEA0/IO107RSB1	59	GDC1/IO61RSB0	95	GAC1/IO05RSB0
24	VMV1	60	GCC2/IO59RSB0	96	GAC0/IO04RSB0
25	GNDQ	61	GCB2/IO58RSB0	97	GAB1/IO03RSB0
26	GEA2/IO106RSB1	62	GCA0/IO56RSB0	98	GAB0/IO02RSB0
27	GEB2/IO105RSB1	63	GCA1/IO55RSB0	99	GAA1/IO01RSB0
28	GEC2/IO104RSB1	64	GCC0/IO52RSB0	100	GAA0/IO00RSB0
29	IO102RSB1	65	GCC1/IO51RSB0		
30	IO100RSB1	66	VCCIB0		
31	IO99RSB1	67	GND		
32	IO97RSB1	68	VCC		
33	IO96RSB1	69	IO47RSB0		
34	IO95RSB1	70	GBC2/IO45RSB0		
35	IO94RSB1	71	GBB2/IO43RSB0		
36	IO93RSB1	72	IO42RSB0		

100-Pin VQFP		100-Pin VQFP		100-Pin VQFP	
Pin Number	A3PN125Z Function	Pin Number	A3PN125Z Function	Pin Number	A3PN125Z Function
1	GND	37	VCC	73	GBA2/IO41RSB0
2	GAA2/IO67RSB1	38	GND	74	VMV0
3	IO68RSB1	39	VCCIB1	75	GNDQ
4	GAB2/IO69RSB1	40	IO87RSB1	76	GBA1/IO40RSB0
5	IO132RSB1	41	IO84RSB1	77	GBA0/IO39RSB0
6	GAC2/IO131RSB1	42	IO81RSB1	78	GBB1/IO38RSB0
7	IO130RSB1	43	IO75RSB1	79	GBB0/IO37RSB0
8	IO129RSB1	44	GDC2/IO72RSB1	80	GBC1/IO36RSB0
9	GND	45	GDB2/IO71RSB1	81	GBC0/IO35RSB0
10	GFB1/IO124RSB1	46	GDA2/IO70RSB1	82	IO32RSB0
11	GFB0/IO123RSB1	47	TCK	83	IO28RSB0
12	VCOMPLF	48	TDI	84	IO25RSB0
13	GFA0/IO122RSB1	49	TMS	85	IO22RSB0
14	VCCPLF	50	VMV1	86	IO19RSB0
15	GFA1/IO121RSB1	51	GND	87	VCCIB0
16	GFA2/IO120RSB1	52	VPUMP	88	GND
17	VCC	53	NC	89	VCC
18	VCCIB1	54	TDO	90	IO15RSB0
19	GEC0/IO111RSB1	55	TRST	91	IO13RSB0
20	GEB1/IO110RSB1	56	V _{JTAG}	92	IO11RSB0
21	GEB0/IO109RSB1	57	GDA1/IO65RSB0	93	IO09RSB0
22	GEA1/IO108RSB1	58	GDC0/IO62RSB0	94	IO07RSB0
23	GEA0/IO107RSB1	59	GDC1/IO61RSB0	95	GAC1/IO05RSB0
24	VMV1	60	GCC2/IO59RSB0	96	GAC0/IO04RSB0
25	GNDQ	61	GCB2/IO58RSB0	97	GAB1/IO03RSB0
26	GEA2/IO106RSB1	62	GCA0/IO56RSB0	98	GAB0/IO02RSB0
27	GEB2/IO105RSB1	63	GCA1/IO55RSB0	99	GAA1/IO01RSB0
28	GEC2/IO104RSB1	64	GCC0/IO52RSB0	100	GAA0/IO00RSB0
29	IO102RSB1	65	GCC1/IO51RSB0		
30	IO100RSB1	66	VCCIB0		
31	IO99RSB1	67	GND		
32	IO97RSB1	68	VCC		
33	IO96RSB1	69	IO47RSB0		
34	IO95RSB1	70	GBC2/IO45RSB0		
35	IO94RSB1	71	GBB2/IO43RSB0		
36	IO93RSB1	72	IO42RSB0		

100-Pin VQFP		100-Pin VQFP		100-Pin VQFP	
Pin Number	A3PN250 Function	Pin Number	A3PN250 Function	Pin Number	A3PN250 Function
1	GND	37	VCC	73	GBA2/IO20RSB1
2	GAA2/IO67RSB3	38	GND	74	VMV1
3	IO66RSB3	39	VCCIB2	75	GNDQ
4	GAB2/IO65RSB3	40	IO39RSB2	76	GBA1/IO19RSB0
5	IO64RSB3	41	IO38RSB2	77	GBA0/IO18RSB0
6	GAC2/IO63RSB3	42	IO37RSB2	78	GBB1/IO17RSB0
7	IO62RSB3	43	GDC2/IO36RSB2	79	GBB0/IO16RSB0
8	IO61RSB3	44	GDB2/IO35RSB2	80	GBC1/IO15RSB0
9	GND	45	GDA2/IO34RSB2	81	GBC0/IO14RSB0
10	GFB1/IO60RSB3	46	GNDQ	82	IO13RSB0
11	GFB0/IO59RSB3	47	TCK	83	IO12RSB0
12	VCOMPLF	48	TDI	84	IO11RSB0
13	GFA0/IO57RSB3	49	TMS	85	IO10RSB0
14	VCCPLF	50	VMV2	86	IO09RSB0
15	GFA1/IO58RSB3	51	GND	87	VCCIB0
16	GFA2/IO56RSB3	52	VPUMP	88	GND
17	VCC	53	NC	89	VCC
18	VCCIB3	54	TDO	90	IO08RSB0
19	GFC2/IO55RSB3	55	TRST	91	IO07RSB0
20	GEC1/IO54RSB3	56	VJTAG	92	IO06RSB0
21	GEC0/IO53RSB3	57	GDA1/IO33RSB1	93	GAC1/IO05RSB0
22	GEA1/IO52RSB3	58	GDC0/IO32RSB1	94	GAC0/IO04RSB0
23	GEA0/IO51RSB3	59	GDC1/IO31RSB1	95	GAB1/IO03RSB0
24	VMV3	60	IO30RSB1	96	GAB0/IO02RSB0
25	GNDQ	61	GCB2/IO29RSB1	97	GAA1/IO01RSB0
26	GEA2/IO50RSB2	62	GCA1/IO27RSB1	98	GAA0/IO00RSB0
27	GEB2/IO49RSB2	63	GCA0/IO28RSB1	99	GNDQ
28	GEC2/IO48RSB2	64	GCC0/IO26RSB1	100	VMV0
29	IO47RSB2	65	GCC1/IO25RSB1		
30	IO46RSB2	66	VCCIB1		
31	IO45RSB2	67	GND		
32	IO44RSB2	68	VCC		
33	IO43RSB2	69	IO24RSB1		
34	IO42RSB2	70	GBC2/IO23RSB1		
35	IO41RSB2	71	GBB2/IO22RSB1		
36	IO40RSB2	72	IO21RSB1		

100-Pin VQFP		100-Pin VQFP		100-Pin VQFP	
Pin Number	A3PN250Z Function	Pin Number	A3PN250Z Function	Pin Number	A3PN250Z Function
1	GND	37	VCC	73	GBA2/IO20RSB1
2	GAA2/IO67RSB3	38	GND	74	VMV1
3	IO66RSB3	39	VCCIB2	75	GNDQ
4	GAB2/IO65RSB3	40	IO39RSB2	76	GBA1/IO19RSB0
5	IO64RSB3	41	IO38RSB2	77	GBA0/IO18RSB0
6	GAC2/IO63RSB3	42	IO37RSB2	78	GBB1/IO17RSB0
7	IO62RSB3	43	GDC2/IO36RSB2	79	GBB0/IO16RSB0
8	IO61RSB3	44	GDB2/IO35RSB2	80	GBC1/IO15RSB0
9	GND	45	GDA2/IO34RSB2	81	GBC0/IO14RSB0
10	GFB1/IO60RSB3	46	GNDQ	82	IO13RSB0
11	GFB0/IO59RSB3	47	TCK	83	IO12RSB0
12	VCOMPLF	48	TDI	84	IO11RSB0
13	GFA0/IO57RSB3	49	TMS	85	IO10RSB0
14	VCCPLF	50	VMV2	86	IO09RSB0
15	GFA1/IO58RSB3	51	GND	87	VCCIB0
16	GFA2/IO56RSB3	52	VPUMP	88	GND
17	VCC	53	NC	89	VCC
18	VCCIB3	54	TDO	90	IO08RSB0
19	GFC2/IO55RSB3	55	TRST	91	IO07RSB0
20	GEC1/IO54RSB3	56	VJTAG	92	IO06RSB0
21	GEC0/IO53RSB3	57	GDA1/IO33RSB1	93	GAC1/IO05RSB0
22	GEA1/IO52RSB3	58	GDC0/IO32RSB1	94	GAC0/IO04RSB0
23	GEA0/IO51RSB3	59	GDC1/IO31RSB1	95	GAB1/IO03RSB0
24	VMV3	60	IO30RSB1	96	GAB0/IO02RSB0
25	GNDQ	61	GCB2/IO29RSB1	97	GAA1/IO01RSB0
26	GEA2/IO50RSB2	62	GCA1/IO27RSB1	98	GAA0/IO00RSB0
27	GEB2/IO49RSB2	63	GCA0/IO28RSB1	99	GNDQ
28	GEC2/IO48RSB2	64	GCC0/IO26RSB1	100	VMV0
29	IO47RSB2	65	GCC1/IO25RSB1		
30	IO46RSB2	66	VCCIB1		
31	IO45RSB2	67	GND		
32	IO44RSB2	68	VCC		
33	IO43RSB2	69	IO24RSB1		
34	IO42RSB2	70	GBC2/IO23RSB1		
35	IO41RSB2	71	GBB2/IO22RSB1		
36	IO40RSB2	72	IO21RSB1		

Part Number and Revision Date

Part Number 51700111-003-4

Revised January 2010

List of Changes

The following table lists critical changes that were made in the current version of the chapter.

Previous Version	Changes in Current Version (Advance v0.5)	Page
Advance v0.4 (March 2009)	The "68-Pin QFN" pin table for A3PN030 is new.	3-7
	The "48-Pin QFN", "68-Pin QFN", and "100-Pin VQFP" pin tables for A3PN030Z are new.	3-3, 3-8, 3-11
	The "100-Pin VQFP" pin table for A3PN060Z is new.	3-13
	The "100-Pin VQFP" pin table for A3PN125Z is new	3-15
	The "100-Pin VQFP" pin table for A3PN250Z is new.	3-17
Advance v0.3 (February 2009)	The "100-Pin VQFP" pin table for A3PN030 is new.	3-10
Advance v0.2 (November 2008)	The "100-Pin QFN" section was removed.	N/A
Advance v0.1 (October 2008)	The "48-Pin QFN" pin diagram was revised.	3-1
	Note 2 for the "48-Pin QFN", "68-Pin QFN", and "100-Pin VQFP" pin diagrams was added/changed to "The die attach paddle of the package is tied to ground (GND)."	3-1, 3-4, 3-9
	The "100-Pin VQFP" pin diagram was revised to move the pin IDs to the upper left corner instead of the upper right corner.	3-9

Datasheet Categories

Categories

In order to provide the latest information to designers, some datasheets are published before data has been fully characterized. Datasheets are designated as "Product Brief," "Advance," "Preliminary," and "Production." The definitions of these categories are as follows:

Product Brief

The product brief is a summarized version of a datasheet (advance or production) and contains general product information. This document gives an overview of specific device and family information.

Advance

This version contains initial estimated information based on simulation, other products, devices, or speed grades. This information can be used as estimates, but not for production. This label only applies to the DC and Switching Characteristics chapter of the datasheet and will only be used when the data has not been fully characterized.

Preliminary

The datasheet contains information based on simulation and/or initial characterization. The information is believed to be correct, but changes are possible.

Unmarked (production)

This version contains information that is considered to be final.

Export Administration Regulations (EAR)

The products described in this document are subject to the Export Administration Regulations (EAR). They could require an approved export license prior to export from the United States. An export includes release of product or disclosure of technology to a foreign national inside or outside the United States.

Actel Safety Critical, Life Support, and High-Reliability Applications Policy

The Actel products described in this advance status document may not have completed Actel's qualification process. Actel may amend or enhance products during the product introduction and qualification process, resulting in changes in device functionality or performance. It is the responsibility of each customer to ensure the fitness of any Actel product (but especially a new product) for a particular purpose, including appropriateness for safety-critical, life-support, and other high-reliability applications. Consult Actel's Terms and Conditions for specific liability exclusions relating to life-support applications. A reliability report covering all of Actel's products is available on the Actel website at http://www.actel.com/documents/ORT_Report.pdf. Actel also offers a variety of enhanced qualification and lot acceptance screening procedures. Contact your local Actel sales office for additional reliability information.

Actel, IGLOO, Actel Fusion, ProASIC, Libero, Pigeon Point and the associated logos are trademarks or registered trademarks of Actel Corporation. All other trademarks and service marks are the property of their respective owners.



Actel is the leader in low-power FPGAs and mixed-signal FPGAs and offers the most comprehensive portfolio of system and power management solutions. Power Matters. Learn more at www.actel.com.

Actel Corporation

2061 Stierlin Court
Mountain View, CA
94043-4655 USA

Phone 650.318.4200

Fax 650.318.4600

Actel Europe Ltd.

River Court, Meadows Business Park
Station Approach, Blackwater
Camberley Surrey GU17 9AB
United Kingdom

Phone +44 (0) 1276 609 300

Fax +44 (0) 1276 607 540

Actel Japan

EXOS Ebisu Building 4F
1-24-14 Ebisu Shibuya-ku
Tokyo 150 Japan

Phone +81.03.3445.7671

Fax +81.03.3445.7668

<http://jp.actel.com>

Actel Hong Kong

Room 2107, China Resources Building
26 Harbour Road
Wanchai, Hong Kong

Phone +852 2185 6460

Fax +852 2185 6488

www.actel.com.cn