

# GaAs IC 4 Bit Digital Attenuator With Driver 2 dB LSB DC–2 GHz



AK100-25

## Features

- Attenuation in 2 dB Steps to 30 dB
- Low DC Current Consumption  
< 10 mA Total
- Integral Driver  $\pm 5$  V Supply Voltages
- Low Cost SOIC-16 Plastic Package

## Description

The AK100-25 is an IC FET digital attenuator consisting of four monolithic attenuators with an LSB of 2 dB and a total attenuation of 30 dB with all attenuators connected. The device has integral drivers for each bit requiring less than 3 mA per bit. DC supply voltages of  $\pm 5$  V are required. The attenuator is packaged in a 16 lead plastic SOIC.

## SOIC-16

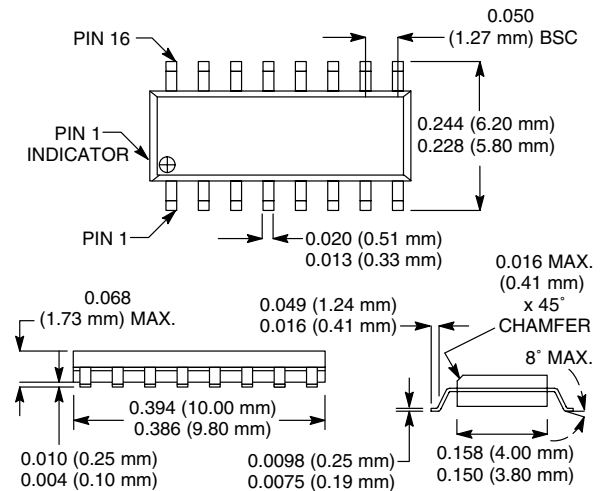

## Electrical Specifications at 25°C (+5 V, -5 V)

| Parameter <sup>1</sup>                    | Frequency <sup>2</sup> | Min.                                  | Typ.  | Max.  | Unit |
|---|------------------------|---------------------------------------|-------|-------|------|
| Insertion Loss <sup>3</sup>               | DC–0.5 GHz             |                                       | 1.8   | 2.0   | dB   |
|   | DC–1.0 GHz             |                                       | 2.0   | 2.5   | dB   |
|   | DC–2.0 GHz             |                                       | 3.0   | 3.5   | dB   |
| Attenuation Accuracy per Bit <sup>4</sup> | DC–2.0 GHz             | +(0.3 dB + 3% of Attenuation Setting) |       |       | dB   |
| VSWR (I/O)                                | DC–2.0 GHz             |                                       | 1.4:1 | 1.6:1 |      |

## Operating Characteristics at 25°C (+5 V, -5 V)

| Parameter                              | Condition                        | Frequency    | Min. | Typ. | Max. | Unit |
|--|----------------------------------|--------------|------|------|------|------|
| Switching Characteristics <sup>5</sup> | Rise, Fall (10/90% or 90/10% RF) |              |      | 10   |      | ns   |
|  | On, Off (50% CTL to 90/10% RF)   |              |      | 20   |      | ns   |
|  | Video Feedthru                   |              |      | 30   |      | mV   |
| Input Power for 1 dB Compression       |                                  | 0.50–2.0 GHz |      | +25  |      | dBm  |
|  |                                  | 0.05 GHz     |      | +16  |      | dBm  |
| Intermodulation Intercept Point (IP3)  | For Two-tone Input Power +13 dBm | 0.50–2.0 GHz |      | +43  |      | dBm  |
|  |                                  | 0.05 GHz     |      | +30  |      | dBm  |
| Control Voltages                       | $V_{Low}$                        |              | 0.0  |      | 0.2  | V    |
|  | $V_{High}$                       |              | 4.5  |      | 5.0  | V    |
| Supply Voltages <sup>6,7</sup>         | +5 V $\pm$ 0.2 V @ 3 mA Typ.     |              | 4.8  |      | 5.2  | V    |
|  | -5 V $\pm$ 0.20 V @ 10 mA Typ.   |              | -4.8 |      | -5.2 | V    |

1. All measurements made in a 50  $\Omega$  system, unless otherwise specified.
2. DC = 300 kHz.
3. Insertion loss changes by 0.003 dB/ $^{\circ}$ C.
4. Attenuation referenced to insertion loss.
5. Video feedthru measured with 1 ns risetime pulse and 500 MHz bandwidth.
6. Supply voltage and ground must be connected before control voltage is applied. Use of toggle switches or other similar components may produce voltage spikes which can cause irreversible damage to the device.
7. Current drain @ 85 $^{\circ}$ C = 5 mA Typ. @ +5 V, 14 mA Typ. @ -5 V.

**Typical Performance Data (+5 V, -5 V)**

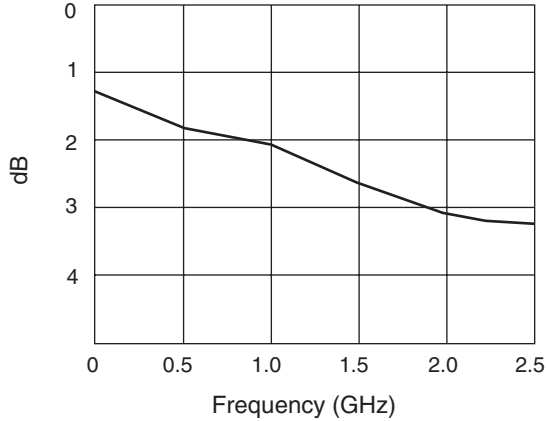

**Insertion Loss vs. Frequency**

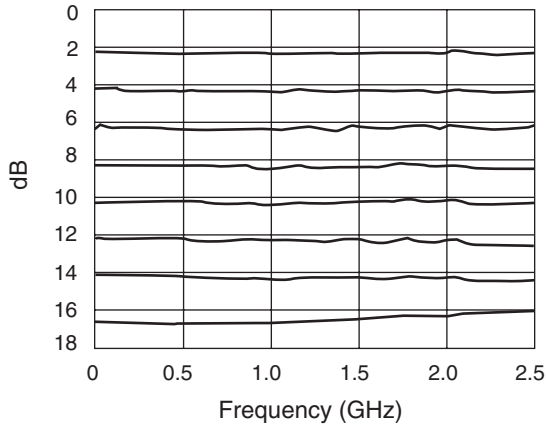

**Attenuation 2 dB to 16 dB**

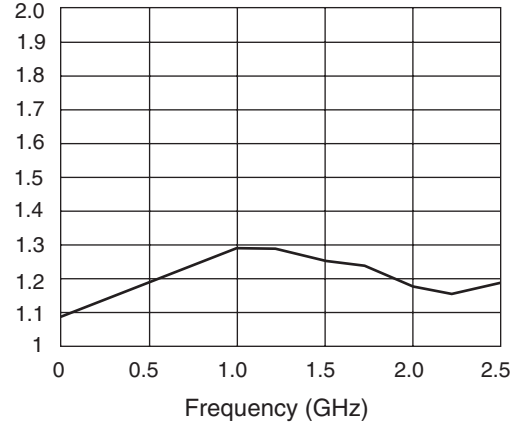

**Typical VSWR vs. Frequency (All States)**

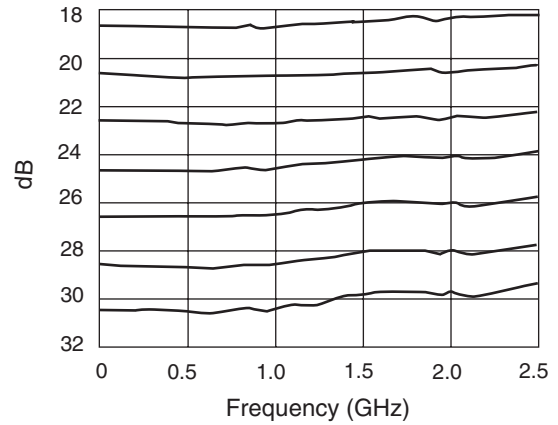

**Attenuation 18 dB to 30 dB**

**Absolute Maximum Ratings**

| Characteristic        | Value                             |
|-----------------------|-----------------------------------|
| RF Input Power        | 0.5 W > 500 MHz<br>0.1 W @ 50 MHz |
| Supply Voltage        | +6 V, -6 V                        |
| Control Voltage       | -0.2 V, +6 V                      |
| Operating Temperature | 0°C to +70°C                      |
| Storage Temperature   | -65°C to +150°C                   |
| $\Theta_{JC}$         | 30°C/W                            |

**Pin Out**

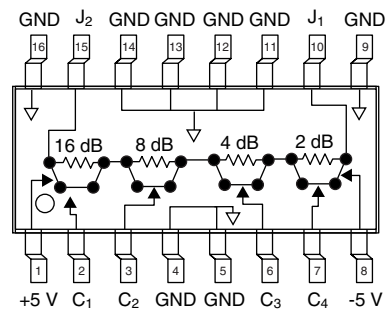

**Truth Table**

| C <sub>1</sub> | C <sub>2</sub> | C <sub>3</sub> | C <sub>4</sub> | Attenuation<br>J <sub>1</sub> -J <sub>2</sub> |
|----------------|----------------|----------------|----------------|---|
| 16 dB          | 8 dB           | 4 dB           | 2 dB           | Reference I.L.                                |
| 0              | 0              | 0              | 0              | Reference I.L.                                |
| 0              | 0              | 0              | 1              | 2 dB  |
| 0              | 0              | 1              | 0              | 4 dB  |
| 0              | 1              | 0              | 0              | 8 dB  |
| 1              | 0              | 0              | 0              | 16 dB   |
| 1              | 1              | 1              | 1              | 30 dB   |

"0" = 0.0 to 0.2 V, "1" = 4.5 to 5.0 V.