125 Megabaud Versatile Link The Versatile Fiber Optic Connection

Technical Data

HFBR-0507 Series HFBR-15X7 Transmitters HFBR-25X6 Receivers

Features

- Data Transmission at Signal Rates of 1 to 125 MBd over Distances of 100 Meters
- Compatible with Inexpensive, Easily Terminated Plastic Optical Fiber, and with Large Core Silica Fiber
- High Voltage Isolation
- Transmitter and Receiver Application Circuit Schematics and Recommended Board Layouts Available
- Interlocking Feature for Single Channel or Duplex Links, in a Vertical or Horizontal Mount Configuration

Applications

- Intra-System Links: Board-to-Board, Rack-to-Rack
- Telecommunications Switching Systems
- Computer-to-Peripheral Data Links, PC Bus Extension
- Industrial Control
- Proprietary LANs
- Digitized Video
- Medical Instruments

- Reduction of Lightning and Voltage Transient Susceptibility

Description

The 125 MBd Versatile Link (HFBR-0507 Series) is the most cost-effective fiber-optic solution for transmission of 125 MBd data over 100 meters. The data link consists of a 650 nm LED transmitter, HFBR-15X7, and a PIN/preamp receiver, HFBR-25X6. These can be used with low-cost plastic or silica fiber. One mm diameter plastic fiber provides the lowest cost solution for distances under 25 meters. The lower attenuation of silica fiber allows data transmission over longer distance, for a small difference in cost. These components can be used for high speed data links without the problems common with copper wire solutions, at a competitive cost.

The HFBR-15X7 transmitter is a high power 650 nm LED in a low cost plastic housing designed to efficiently couple power into 1 mm diameter plastic optical fiber



and 200 μm Hard Clad Silica (HCS[®]) fiber. With the recommended drive circuit, the LED operates at speeds from 1-125 MBd. The HFBR-25X6 is a high bandwidth analog receiver containing a PIN photodiode and internal transimpedance amplifier. With the recommended application circuit for 125 MBd operation, the performance of the complete data link is specified for of 0-25 meters with plastic fiber and 0-100 meters with 200 μm HCS[®] fiber. A wide variety of other digitizing circuits can be combined with the HFBR-0507 Series to optimize performance and cost at higher and lower data rates.

**HFBR-0507 Series
125 MBd Data Link**

Data link operating conditions and performance are specified for the HFBR-15X7 transmitter and HFBR-25X6 receiver in the

recommended applications circuits shown in Figure 1. This circuit has been optimized for 125 MBd operation. The Applications Engineering Department in the Hewlett-Packard Optical

Communication Division is available to assist in optimizing link performance for higher or lower speed operation.

Recommended Operating Conditions for the Circuits in Figures 1 and 2.

Parameter	Symbol	Min.	Max.	Unit	Reference
Ambient Temperature	T _A	0	70	°C	
Supply Voltage	V _{CC}	+4.75	+5.25	V	
Data Input Voltage – Low	V _{IL}	V _{CC} -1.89	V _{CC} -1.62	V	
Data Input Voltage – High	V _{IH}	V _{CC} -1.06	V _{CC} -0.70	V	
Data Output Load	R _L	45	55	Ω	Note 1
Signaling Rate	f _S	1	125	MBd	
Duty Cycle	D.C.	40	60	%	Note 2

Link Performance: 1-125 MBd, BER ≤ 10⁻⁹, under recommended operating conditions with recommended transmit and receive application circuits.

Parameter	Symbol	Min. ^[3]	Typ. ^[4]	Max.	Unit	Condition	Reference
Optical Power Budget, 1 m POF	OPB _{POF}	11	16		dB		Note 5,6,7
Optical Power Margin, 20 m Standard POF	OPM _{POF,20}	3	6		dB		Note 5,6,7
Link Distance with Standard 1 mm POF	1	20	27		m		
Optical Power Margin, 25 m Low Loss POF	OPM _{POF,25}	3	6		dB		Note 5,6,7
Link Distance with Extra Low Loss 1 mm POF	1	25	32		m		
Optical Power Budget, 1 m HCS	OPB _{HCS}	7	12		dB		Note 5,6,7
Optical Power Margin, 100 m HCS	OPM _{HCS,100}	3	6		dB		Note 5,6,7
Link Distance with HCS Cable	1	100	125		m		

Notes:

1. If the output of U4C in Figure 1, page 4 is transmitted via coaxial cable, terminate with a 50 Ω resistor to V_{CC} - 2 V.
2. Run length limited code with maximum run length of 10 μs.
3. Minimum link performance is projected based on the worst case specifications of the HFBR-15X7 transmitter, HFBR-25X6 receiver, and POF cable, and the typical performance of other components (e.g. logic gates, transistors, resistors, capacitors, quantizer, HCS cable).
4. Typical performance is at 25°C, 125 MBd, and is measured with typical values of all circuit components.
5. Standard cable is HFBR-RXYYYY plastic optical fiber, with a maximum attenuation of 0.24 dB/m at 650 nm and NA = 0.5. Extra low loss cable is HFBR-EXYYYY plastic optical fiber, with a maximum attenuation of 0.19 dB/m at 650 nm and NA = 0.5. HCS cable is HFBR-H/VXYYYY glass optical fiber, with a maximum attenuation of 10 dB/km at 650 nm and NA = 0.37.
6. Optical Power Budget is the difference between the transmitter output power and the receiver sensitivity, measured after 1 meter of fiber. The minimum OPB is based on the limits of optical component performance over temperature, process, and recommended power supply variation.
7. The Optical Power Margin is the available OPB after including the effects of attenuation and modal dispersion for the minimum link distance: OPM = OPB - (attenuation power loss + modal dispersion power penalty). The minimum OPM is the margin available for longterm LED LOP degradation and additional fixed passive losses (such as in-line connectors) in addition to the minimum specified distance.

Plastic Optical Fiber (1 mm POF) Transmitter Application Circuit:

Performance of the HFBR-15X7 transmitter in the recommended application circuit (Figure 1) for POF; 1-125 MBd, 25°C.

Parameter	Symbol	Typical	Unit	Condition	Note
Average Optical Power 1 mm POF	P_{avg}	-9.7	dBm	50% Duty Cycle	Note 1, Fig 3
Average Modulated Power 1 mm POF	P_{mod}	-11.3	dBm		Note 2, Fig 3
Optical Rise Time (10% to 90%)	t_r	2.1	ns	5 MHz	
Optical Fall Time (90% to 10%)	t_f	2.8	ns	5 MHz	
High Level LED Current (On)	$I_{F,H}$	19	mA		Note 3
Low Level LED Current (Off)	$I_{F,L}$	3	mA		Note 3
Optical Overshoot - 1 mm POF		45	%		
Transmitter Application Circuit Current Consumption - 1 mm POF	I_{CC}	110	mA		Figure 1

Hard Clad Silica Fiber (200 μm HCS) Transmitter Application Circuit: Performance of the HFBR-15X7 transmitter in the recommended application circuit (Figure 1) for HCS; 1-125 MBd, 25°C.

Parameter	Symbol	Typical	Unit	Condition	Note
Average Optical Power 200 μm HCS	P_{avg}	-14.6	dBm	50% Duty Cycle	Note 1, Fig 3
Average Modulated Power 200 μm HCS	P_{mod}	-16.2	dBm		Note 2, Fig 3
Optical Rise Time (10% to 90%)	t_r	3.1	ns	5 MHz	
Optical Fall Time (90% to 10%)	t_f	3.4	ns	5 MHz	
High Level LED Current (On)	$I_{F,H}$	60	mA		Note 3
Low Level LED Current (Off)	$I_{F,L}$	6	mA		Note 3
Optical Overshoot - 200 μm HCS		30	%		
Transmitter Application Circuit Current Consumption - 200 μm HCS	I_{CC}	130	mA		Figure 1

Notes:

1. Average optical power is measured with an average power meter at 50% duty cycle, after 1 meter of fiber.
2. To allow the LED to switch at high speeds, the recommended drive circuit modulates LED light output between two non-zero power levels. The modulated (useful) power is the difference between the high and low level of light output power (transmitted) or input power (received), which can be measured with an average power meter as a function of duty cycle (see Figure 3). Average Modulated Power is defined as one half the slope of the average power versus duty cycle:

$$\text{Average Modulated Power} = \frac{[P_{avg} @ 80\% \text{ duty cycle} - P_{avg} @ 20\% \text{ duty cycle}]}{(2) [0.80 - 0.20]}$$

3. High and low level LED currents refer to the current through the HFBR-15X7 LED. The low level LED “off” current, sometimes referred to as “hold-on” current, is prebias supplied to the LED during the off state to facilitate fast switching speeds.

Plastic and Hard Clad Silica Optical Fiber Receiver Application Circuit:

Performance^[4] of the HFBR-25X6 receiver in the recommended application circuit (Figure 1); 1-125 MBd, 25°C unless otherwise stated.

Parameter	Symbol	Typical	Unit	Condition	Note
Data Output Voltage - Low	V_{OL}	$V_{CC} - 1.7$	V	$R_L = 50 \Omega$	Note 5
Data Output Voltage - High	V_{OH}	$V_{CC} - 0.9$	V	$R_L = 50 \Omega$	Note 5
Receiver Sensitivity to Average Modulated Optical Power 1 mm POF	P_{min}	-27.5	dBm	50% eye opening	Note 2
Receiver Sensitivity to Average Modulated Optical Power 200 μ m HCS	P_{min}	-28.5	dBm	50% eye opening	Note 2
Receiver Overdrive Level of Average Modulated Optical Power 1 mm POF	P_{max}	-7.5	dBm	50% eye opening	Note 2
Receiver Overdrive Level of Average Modulated Optical Power 200 μ m HCS	P_{max}	-10.5	dBm	50% eye opening	Note 2
Receiver Application Circuit Current Consumption	I_{CC}	85	mA	$R_L = \infty$	Figure 1

Notes:

- Performance in response to a signal from the HFBR-15X7 transmitter driven with the recommended circuit at 1-125 MBd over 1 meter of HFBR-R/EXXYYY plastic optical fiber or 1 meter of HFBR-H/VXXYYY hard clad silica optical fiber.
- Terminated through a 50 Ω resistor to $V_{CC} - 2$ V.
- If there is no input optical power to the receiver, electrical noise can result in false triggering of the receiver. In typical applications, data encoding and error detection prevent random triggering from being interpreted as valid data. Refer to Applications Note 1066 for design guidelines.

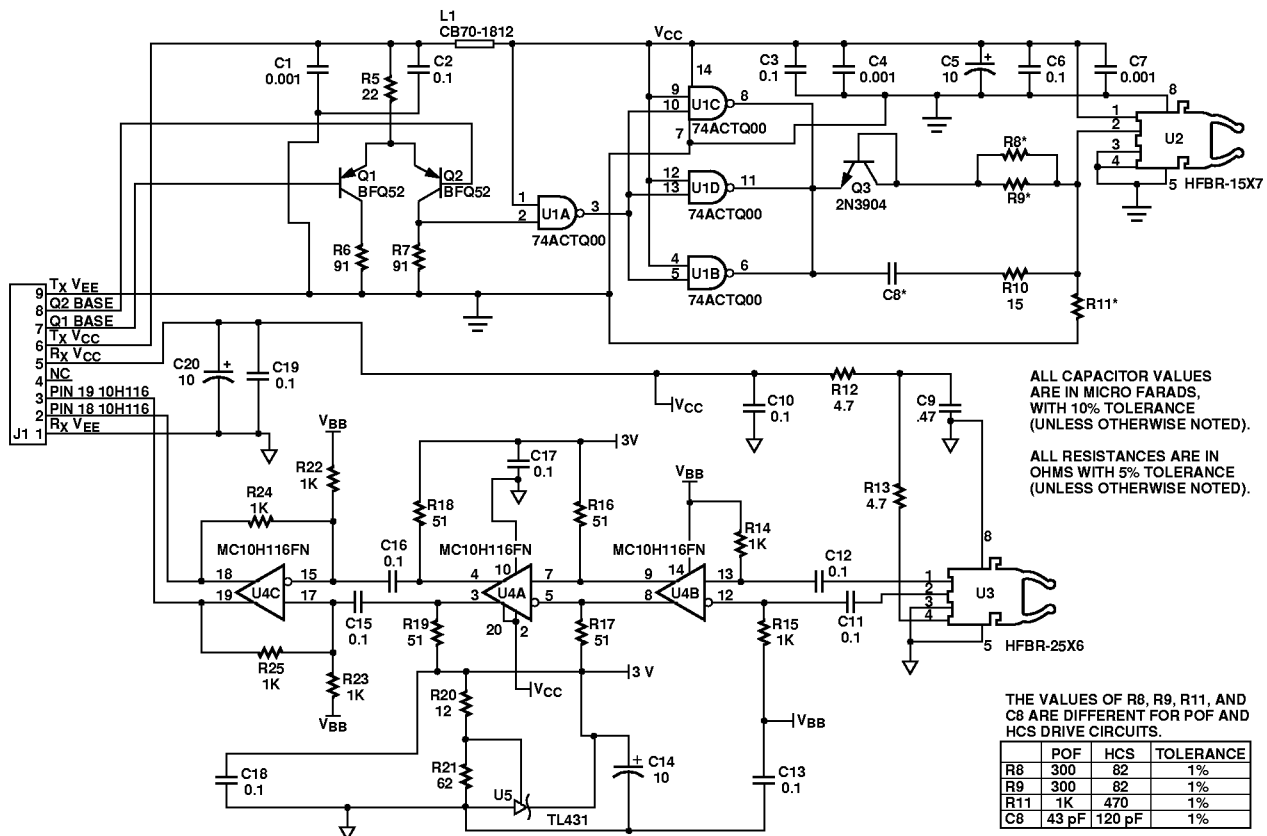

Figure 1. Transmitter and Receiver Application Circuit with +5 V ECL Inputs and Outputs.

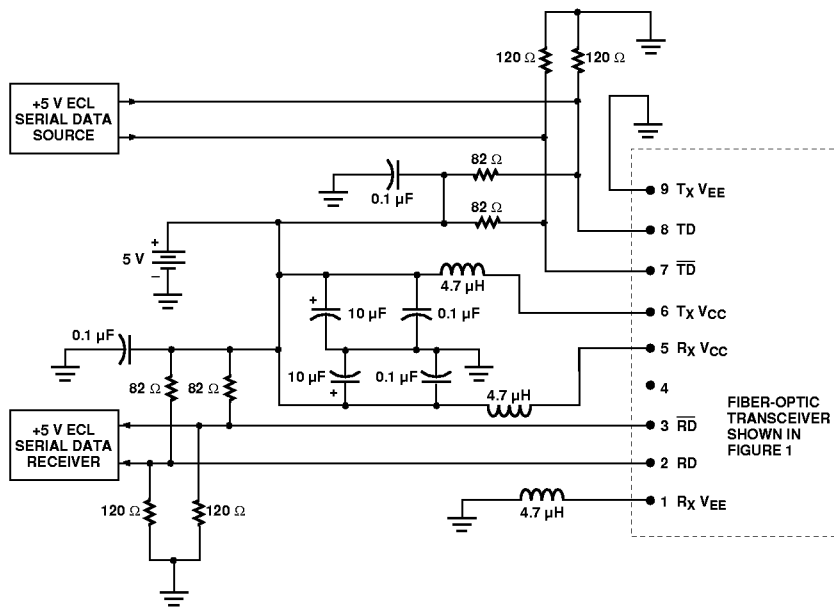

Figure 2. Recommended Power Supply Filter and +5 V ECL Signal Terminations for the Transmitter and Receiver Application Circuit of Figure 1.

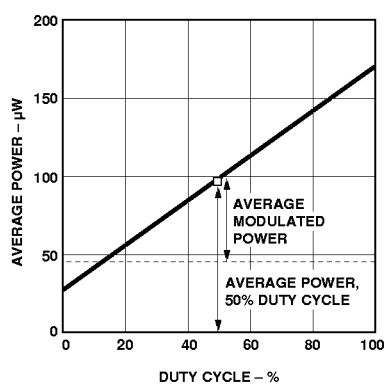

Figure 3. Average Modulated Power.

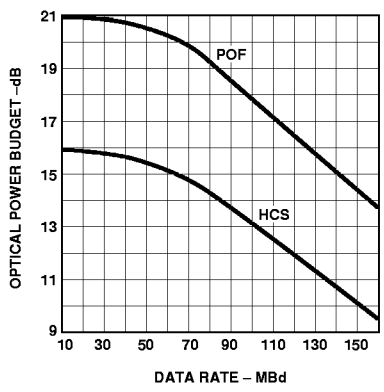

Figure 4. Typical Optical Power Budget vs. Data Rate.